

(Model.)

S. D. ENGLE.  
ENGRAVING MACHINE.

No. 275,618.

Patented Apr. 10, 1883.

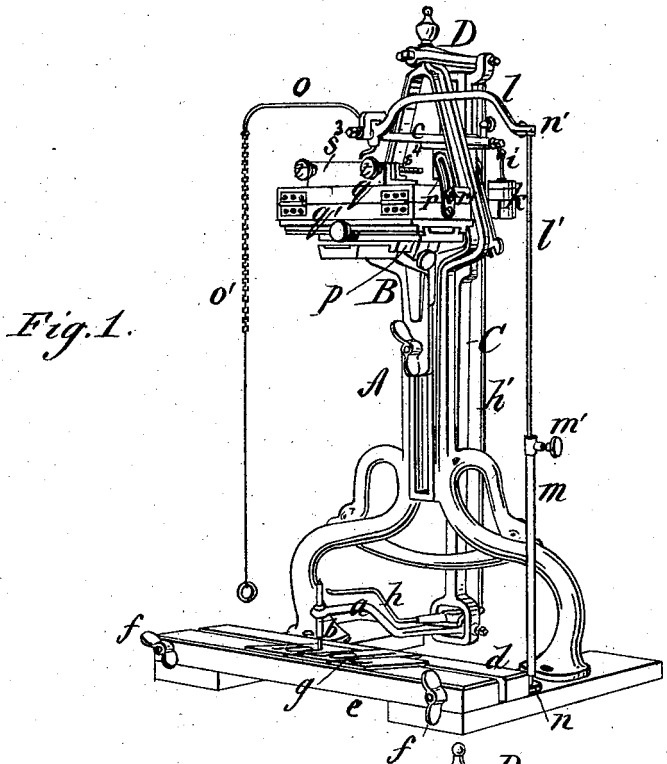

Fig. 1.

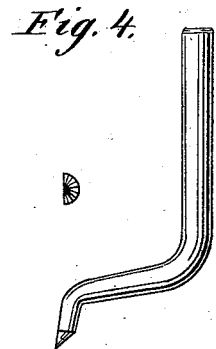

Fig. 4.

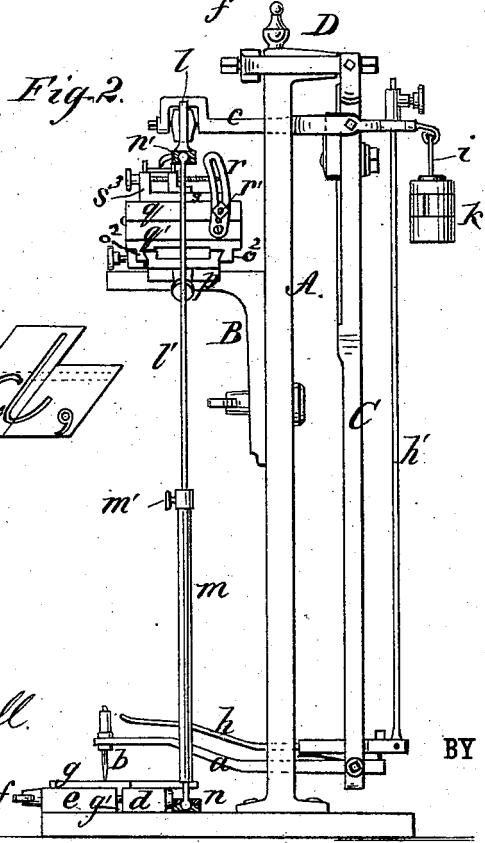

Fig. 2.

Fig. 3.

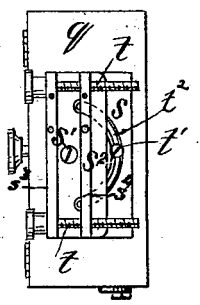

Fig. 5.



WITNESSES:

*Donn Twitchell.*  
*L. Sedgwick*

INVENTOR:

*S. D. Engle*  
*Mum Co*  
ATTORNEYS.

BY

# UNITED STATES PATENT OFFICE.

STEPHEN D. ENGLE, OF HAZLETON, PENNSYLVANIA.

## ENGRAVING-MACHINE.

SPECIFICATION forming part of Letters Patent No. 275,618, dated April 10, 1883.

Application filed November 22, 1882. (Model.)

To all whom it may concern:

Be it known that I, STEPHEN D. ENGLE, of Hazleton, in the county of Luzerne and State of Pennsylvania, have invented a new and Improved Engraving-Machine, of which the following is a full, clear, and exact description.

My improvements relate to engraving-machines of the class shown in Letters Patent granted to me September 6, 1881, No. 246,737; and the invention consists in certain features of improvement, as hereinafter described and claimed.

Reference is to be had to the accompanying drawings, forming part of this specification, in which similar letters of reference indicate corresponding parts in all the figures.

Figure 1 is a front perspective view of the machine. Fig. 2 is a side elevation, partly in section. Fig. 3 is a plan view of the work-clamp. Fig. 4 shows the graving-tool in larger size. Fig. 5 represents the type made use of in the machine.

A is the main standard of the machine, carrying the adjustable bracket B, that supports the work-bed. C is the pantograph-arm, suspended by a gimbal at D from the top of the standard A, and fitted at its lower end with a pivoted arm, *a*, that carries the tracer *b*. *c* is the tool-arm pivoted on the upper end of the pantograph-arm C, and adjustable lengthwise of the same. These parts are substantially similar to those shown in the Letters Patent aforesaid.

Upon the base of the machine is a type-clamp, consisting of a fixed bar, *d*, and a movable bar, *e*, upon rods that are fitted with nuts *f*, so that the bar *e* can be moved to clamp the type. The type-plates *g* are formed with tongues *g'*, that project between the bars *d* and *e*, so as to be clamped thereby; and these tongues are formed on the plate at a uniform distance from the lower edges, and on the smaller letters come near the upper edges of the plate, so that all unnecessary and useless metal in the plates is dispensed with. The type are cast instead of being cut, as usual, and can thus be made to lie solidly and fit closely. The tracer-arm *a* is fitted with a lever, *h*, which connects by a rod, *h'*, to the tool-arm *c*, for moving the tool down upon the work, as in my previous patent. Upon the rear end of the tool-arm is a pendant, *i*, that

receives one or more weights, *k*, that serve to balance the tool-arm, and thus regulate the pressure on the cutter when fine lines are being made. On the forward end of the tool-arm is pivoted an arm, *l*, that extends at one side, and is provided at its outer end with a rod, *l'*. The lower end of the rod *l'* enters a hollow post, *m*, and is clamped therein by a set-screw, *m'*. The tube *m* is connected to the base of the machine by a ball-and-socket joint at *n*, and the upper end of the rod *l'* is connected to the arm *l* by a ball-and-socket joint at *n'*, so as to allow the cutter, which is attached on the inner end of the arm *l*, to be carried across the work and remain in nearly a vertical plane at all times. To the arm *l* is attached a spring-arm, *o*, from which a chain or wire, *o'*, extends downward to a convenient position for being drawn on by the operator for use in giving additional pressure to the cutter in shading the letters.

The work-bed is carried by a slide, *p*, that is adjustable upon the bracket B to and from the standard A. The bed consists of two portions, *q* *q'*, which are hinged together and adjustable lengthwise upon the slide *p*. Upon the lower portion, *q'*, is a slotted arm, *r*, which is attached to the upper portion, *q*, by a screw, *r'*, passing through the slot of the arm, so that the upper portion, *q*, of the bed may be set at any desired inclination. Upon this bed is a clamp or chuck, (shown most clearly in Fig. 3,) consisting of a plate, *s*, pivoted at *s'* to the upper face of the part of the work-bed lettered *q*, and provided with the upwardly-projecting longitudinal flange *s<sup>3</sup>* and curved slot *t<sup>2</sup>*, the plate *s* being adapted to be clamped in any position by the screw *t'*. *s<sup>2</sup>* is a clamping-plate lying on the plate *s*, and provided with an upwardly-projecting flange, *s<sup>4</sup>*. The flanges *s<sup>3</sup>* *s<sup>4</sup>* are provided with upwardly-projecting pins on their upper edges to clamp the work, and are adjusted to and fro by screws *t*. The lower plate, *s*, being pivoted, can be turned to the right or the left, and is guided and clamped by a screw, *t'*, passing through a curved slot, *t<sup>2</sup>*, in the plate *s* into the bed *q*. This construction allows for every possible variety of adjustment required by the work.

In arranging the machine for work the article to be engraved is to be fastened in the clamp upon the bed, and the bracket B is then raised

or lowered, and the tool-arm C correspondingly raised or lowered upon the pantograph-arm, so as to bring the tool-arm in a horizontal position. The rod *l'* is then to be adjusted  
 5 in the tube *m* to bring the arm *l* to a horizontal position. The tracer is then moved by hand over the lines of the type, the lever or trigger *h* being at the same time pressed upon to bring the cutting-tool down upon the work.  
 10 For shading the letters the cord or chain *o'* is to be drawn down by means of the ring at its lower end, so as to give the required pressure upon the spring *o*, the pressure being regulated to increase or diminish the shading, as  
 15 required.

The cutter which I use, and as shown in larger size in Fig. 4, has its point made in the form of a semi-cone, that being the form required in order to do the engraving properly.  
 20 A crook in the shank adapts the cutter to inside work, but for outside work will not be required. The lines of the types shown in Fig. 5 are not continuous. The portions forming the upstrokes do not run into or join the shaded or  
 25 down strokes. This peculiarity is the same in both capital and lower-case letters, the advantage being that as the shaded strokes are the heaviest to cut, if they were run into the upstrokes, there would be a liability of the  
 30 tracer being diverted or run out of place. The shading formed by the cutter is wide enough to cut over, so as to connect the upstroke with the shaded portion in the complete work. All the letters are to be formed in the same man-  
 35 ner.

This machine can be readily used for all varieties of engraving—such as spoons, forks, rings, thimbles, coffin-plates, &c.—the work can be rapidly done, the machine is simple to operate, and it is easily kept under perfect control.  
 40

Having thus described my invention, what I claim as new, and desire to secure by Letters Patent, is—

1. In engraving-machines, a work-bed consisting of the two parts *q q'*, having their outer edges hinged to each other, the lower part, *q'*, being provided with a curved slotted arm, *r*, and the upper part, *q*, with a set-screw, *r'*, passing through the slot in the arm and into

the upper part, *q*, so that the latter may be set  
 50 at any desired inclination, as set forth.

2. The combination, with a work-bed, of the plate *s*, pivoted to the work-bed at *s'*, and provided with the curved slot *t<sup>2</sup>*, having set-screw *t'*, and flange *s<sup>3</sup>*, having pins on its upper edge,  
 55 clamping-plate *s<sup>2</sup>*, provided with flanges *s<sup>4</sup>*, having pins on its upper edge, and adjusting-screws *t*, substantially as shown and described.

3. The combination, with the adjustably-hinged work-bed *q q'*, of the pivoted plate *s*,  
 60 provided with the curved slot *t<sup>2</sup>* and flange *s<sup>3</sup>*, clamping-plate *s<sup>2</sup>*, having flange *s<sup>4</sup>*, adjusting-screws *t*, and tool-carrying arm C, substantially as shown and described.

4. The combination of the adjustably-hinged work-bed *q q'*, having longitudinal flanges *o<sup>2</sup> o<sup>2</sup>* on its under face, and slide *p*, having longitudinal flanges on its upper face, substantially as shown and described, whereby the inclination  
 70 of the part *q* of the work-bed may be varied and the work-bed adjusted lengthwise on the slide, as desired.

5. The combination, with the vertically-adjustable bracket B, of the adjustable slide *p*, provided with transverse flanges on its lower  
 75 face and longitudinal flanges on its upper face, adjustably-hinged work-bed *q q'*, having longitudinal flanges on its under face, pivoted clamping-plates *s s<sup>2</sup>*, constructed as set forth, and adjusting-screws *t*, substantially as shown and  
 80 described.

6. In engraving-machines, the combination, with the pivoted arm *c* and the pantograph-arm C, of the pivoted arm *l*, carrying the graving-tool, and held at its outer end by a jointed  
 85 rod, *l'*, substantially as described.

7. In engraving-machines, the combination of the jointed arm *c*, the arm *l*, pivoted thereto and carrying the graving-tool, the rod *l'*, connected by a ball-joint to the tool-arm, and tube  
 90 *m*, provided with clamping-screws *m'*, and connected by a ball-and-socket joint, *n*, to the base of the machine, substantially as shown and described.

STEPHEN D. ENGLE.

Witnesses:

G. F. KISNER,  
 W. F. MARTZ.