

W. S. EATON.
ENGRAVING MACHINE.

(Application filed Sept. 17, 1900.)

(No Model.)

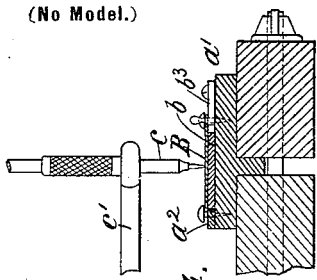

FIG. 4.

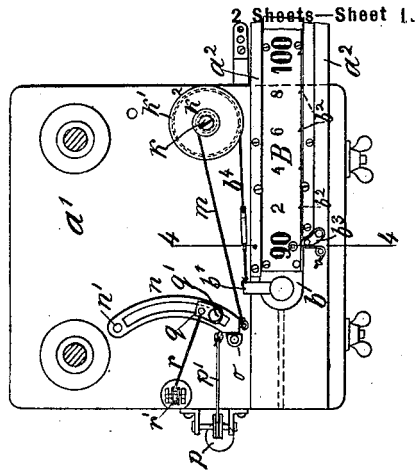

FIG. 3.

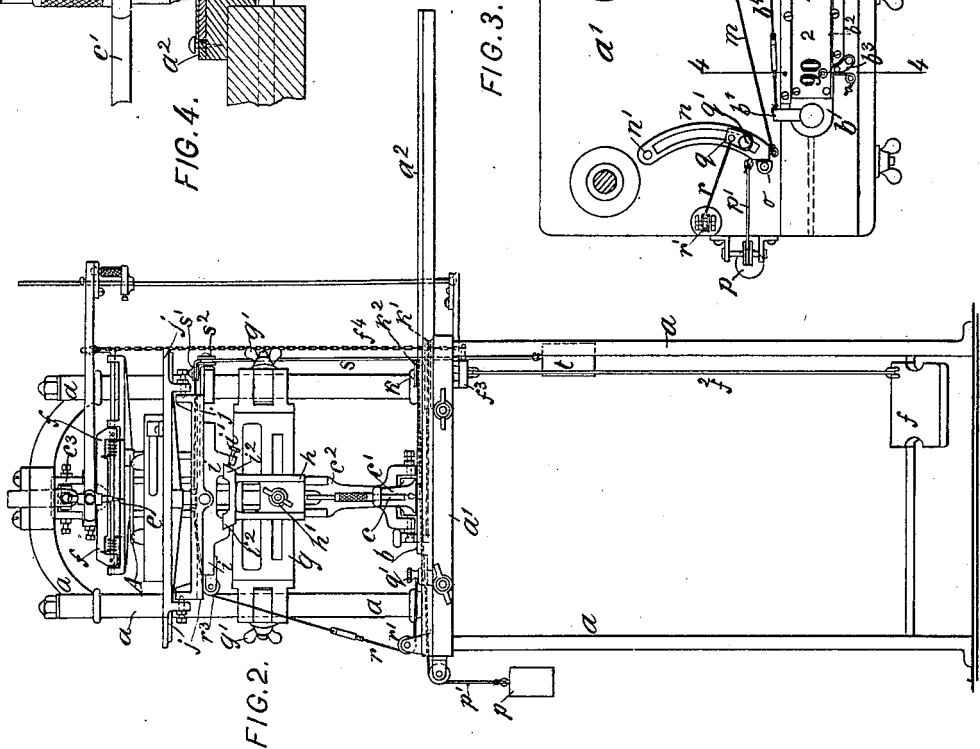

FIG. 2.

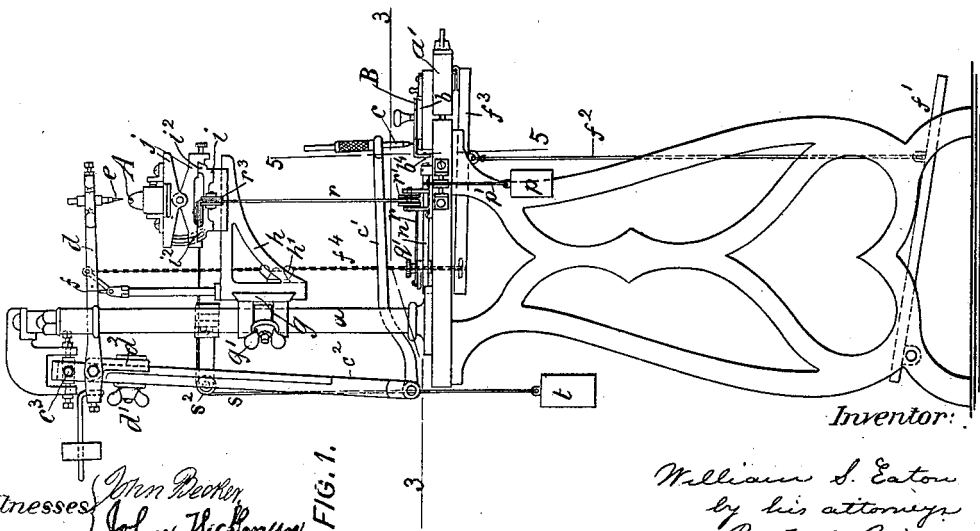

FIG. 1.

Witnesses
John Beckman
John Beckman

Inventor:

William S. Eaton
by his attorneys
Boeder & Brierley

W. S. EATON.
ENGRAVING MACHINE.

(Application filed Sept. 17, 1900.)

(No Model.)

2 Sheets—Sheet 2.

FIG. 5.

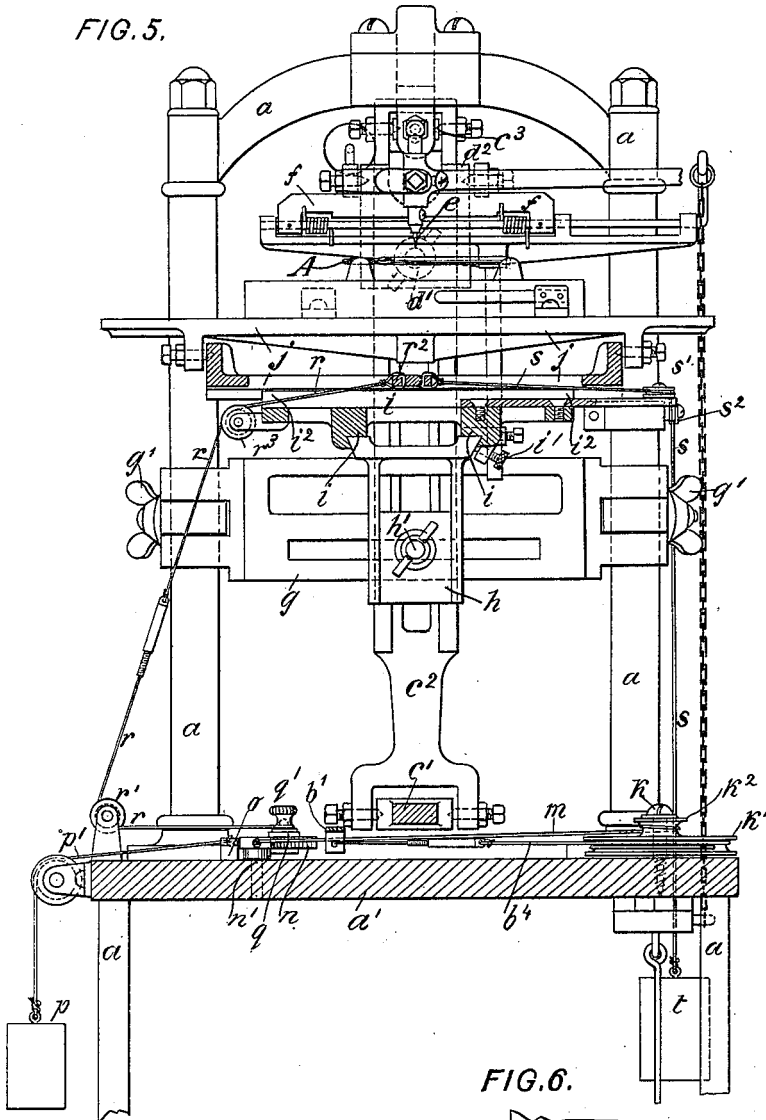

FIG. 6.

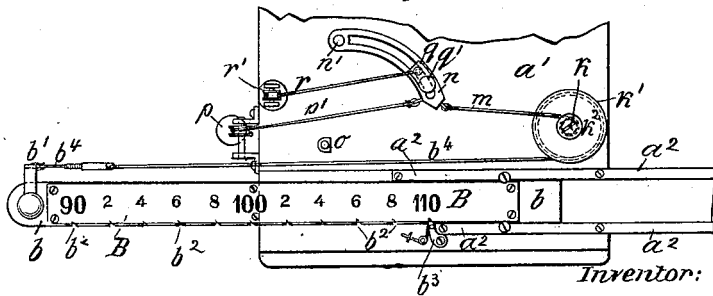
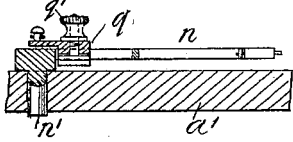

FIG. 7.



Witnesses:
John Becker.
John Hickman.

Inventor:
William S. Eaton
 by his attorneys
Reeder & Rinsen.

UNITED STATES PATENT OFFICE.

WILLIAM S. EATON, OF SAG HARBOR, NEW YORK, ASSIGNOR TO THE
EATON & GLOVER COMPANY, OF NEW YORK, N. Y.

ENGRAVING-MACHINE.

SPECIFICATION forming part of Letters Patent No. 663,563, dated December 11, 1900.

Application filed September 17, 1900. Serial No. 30,253. (No model.)

To all whom it may concern:

Be it known that I, WILLIAM S. EATON, a citizen of the United States, and a resident of Sag Harbor, Suffolk county, State of New York, have invented certain new and useful Improvements in Engraving-Machines, of which the following is a specification.

This invention relates to an engraving-machine more particularly designed for engraving numbers on bodies carrying scales, such as thermometers and the like. The machine is provided with a pattern-plate which may be moved beneath the tracer and impart a proportionate movement to the slide-rest carrying the work. Thus while the pattern-plate may be considerably longer than the work to be engraved, both will be so moved that a given fraction of the pattern will advance simultaneously with a like fraction of the work, and that thus pattern and work run through the machine at the same time.

The machine is so constructed that it may be readily set for larger or smaller work-pieces, which may be properly numbered from one and the same pattern-plate.

In the accompanying drawings, Figure 1 is a side elevation of my improved engraving-machine; Fig. 2, a front elevation thereof; Fig. 3, a horizontal section on line 3 3, Fig. 1; Fig. 4, a cross-section on line 4 4, Fig. 3; Fig. 5, a front elevation, partly in section, of the machine, on a larger scale; Fig. 6, a plan of part of the machine-table and pattern-plate, showing the parts in a different position from Fig. 3; and Fig. 7, a detail section through the lever *n*.

The letter *a* represents the frame of the engraving-machine, and *a'* is the bed-plate, provided with parallel rails *a''* for guiding a laterally-movable slide *b*, to which the pattern-plate B is secured.

c is the tracer, connected by arm *c'* to the lever *c''*, suspended at *c'''* by a universal joint from the machine-frame *a*. To the lever *c''* is adjustably connected, by set-screw *d'*, a slide *d''*, to which the arm *d'*, which carries the engraving-tool *e*, is pivoted, so that in this way the movement of the tracer is transmitted on a reduced scale to the engraving-tool, all as usual. The engraving-tool may be

raised off the work by rest *f*, operated from treadle *f'* by rod *f''*, lever *f'''*, and chain *f''''*.

g is a support which is vertically adjustable on frame *a* and is held in position by set-screws *g'*. The support *g* is engaged by a laterally-movable bracket *h*, which is held in position by clamp-screw *h'* and in turn carries a backwardly and forwardly adjustable base *i*, clamped in position by screw *i'*. The base *i* is provided with rails *i''*, upon which is free to move the laterally-movable slide-rest *j*, to which the thermometer or other work-piece A to be engraved with numbers may be attached in any suitable manner.

In order to transmit a proportionate movement from the pattern-plate B to the slide-rest *j*, I have devised the following construction: From the table *a'* projects a stud *k*, upon which is mounted a double pulley consisting of two sheaves *k'* *k''*, bearing about the same proportion as that between the scale on the pattern-plate and on the thermometer, the drawings showing the proportion as one to four. To the larger sheave *k'* is secured a cord *b''*, which is wound around the sheave and attached at its other end to a projection *b'''* of slide *b*. This slide is provided on one edge with notches *b''''*, adapted to be engaged by a detent *b''''''*, which serves to hold the slide in position, while the lines of the pattern are followed by the tracer. To the smaller sheave *k''* is secured a cord *m*, which is wound around the same and is secured at its other end to the free end of a curved lever *n*, fulcrumed to plate *a'* at *n'*. This free end of lever *n* is normally drawn against a stop *o* by means of a weight *p*, suspended from the lever by a cord *p'*. The lever is preferably slotted, as shown, to form the guide for a slide *q*, movable within the slot along the lever and which may be held in position by a screw-clamp *q'*. To the slide *q* is secured one end of a cord *r*, which runs over pulley *r'* of bed-plate *a'* and over pulley *r''* of base *i* and is attached at *r''''* to the slide-rest *j*. From this slide-rest is suspended by cord *s*, running over pulleys *s'* *s''*, a weight *t*, which has a tendency to draw the slide-rest toward the right.

The operation is as follows: Set the slide *q* at zero—*i. e.*, at the pivoted end *n'* of lever *n*,

Fig. 7. Move the pattern-slide *b* until the first mark of the pattern B (90 in the drawings) is brought underneath the tracer *c*, this being the position shown in Fig. 3. Place
 5 the thermometer upon the slide-rest *j* and secure it thereto in such a position that its first mark is brought underneath the engraving-
 10 (110 in the drawings) is brought underneath the tracer, swinging by this motion the lever *n* without, however, moving the slide-rest *j*. Set the slide *q* forward on lever *n* to move the slide-rest *j* and clamp the slide *q* in posi-
 15 tion as soon as the last mark on the thermometer is brought underneath the engraving-tool. Move the pattern-slide toward the right to again bring its first mark in line with the tracer and to permit weight *p* to swing
 20 lever *n* back against the stop *o*. By the operation thus far described the machine has been set to engrave the figures on a scale of one particular length, and of course the adjustment will hold good for all scales of the
 25 same length.

After the machine has been set in the manner described the tracer is moved over the first figure of the pattern in the usual manner, so that the engraving-tool will cut a simi-
 30 lar figure into the thermometer. The pattern is now fed toward the left until the click *b*³ engages the next notch *b*², and the

engraving operation is repeated. During each movement of the pattern the lever *n* will be swung slightly upon its pivot to move 35 the slide-rest and work in proportion to the movement imparted to the pattern—that is to say, if each movement between notches will advance the pattern-plate one-sixth of its length such movement will advance the 40 thermometer to one-sixth of its length. After the engraving operation is completed the pattern is moved back toward the right into its initial position, Fig. 3, and simultaneously the lever *n* will be swung back against 45 stop *o* by the weight *p*, while the slide-rest *j* will be moved toward the right and into its initial position by the weight *t*. The machine is thus in position to receive and engrave a 50 new work-piece.

What I claim is—

In an engraving-machine, the combination of a pattern-slide with a double pulley connected thereto, a lever also connected to said pulley, a slide engaging the lever, and a slide-rest connected to the slide, substantially as 55 specified.

Signed by me at New York city, county and State of New York, this 15th day of September, 1900.

WILLIAM S. EATON.

Witnesses:

F. V. BRIESEN,
 WILLIAM SCHULZ.