

May 10, 1932.

P. SACKERS ET AL

1,857,570

ENGRAVING MACHINE

Filed Dec. 31, 1928

3 Sheets-Sheet 1

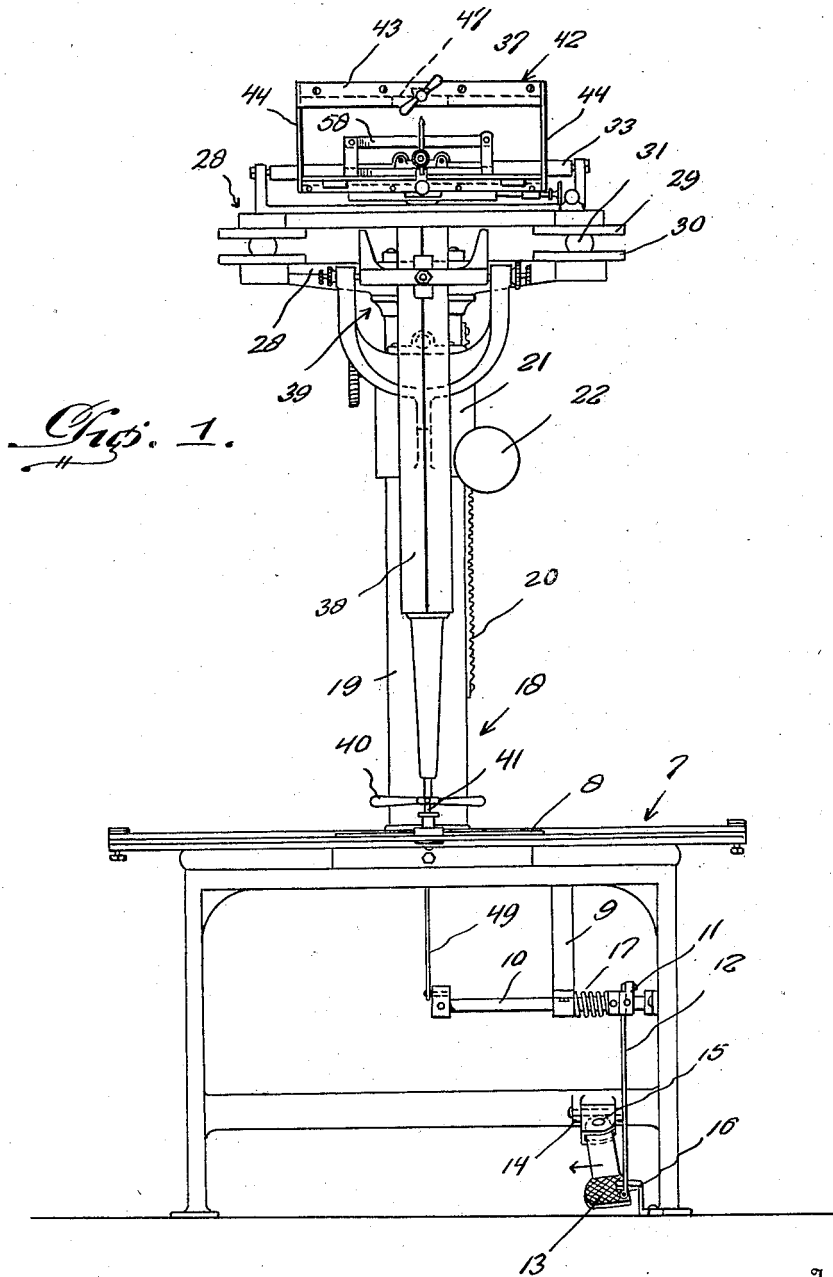

Fig. 1.

Inventors
Peter Sackers,
Irwin Reinhart,
T. G. Straub,

By Stanley Bunch

Attorney

May 10, 1932.

P. SACKERS ET AL

1,857,570

ENGRAVING MACHINE

Filed Dec. 31, 1928

3 Sheets-Sheet 2

Fig. 3.

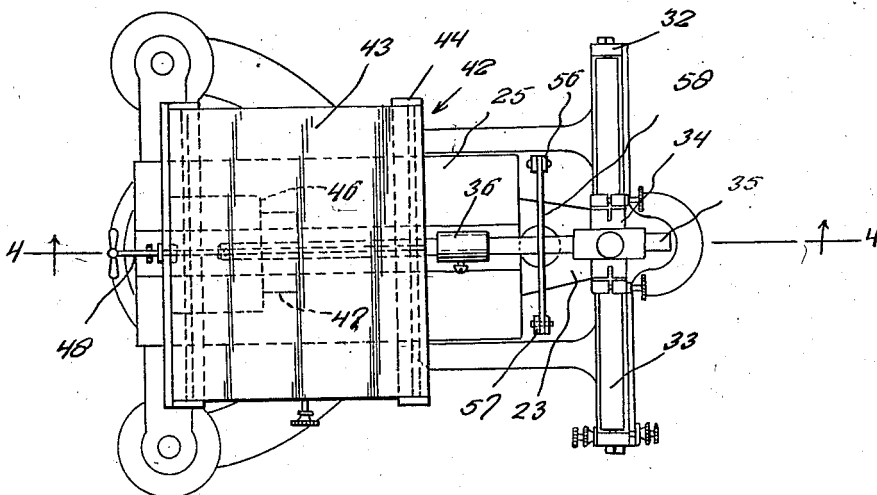
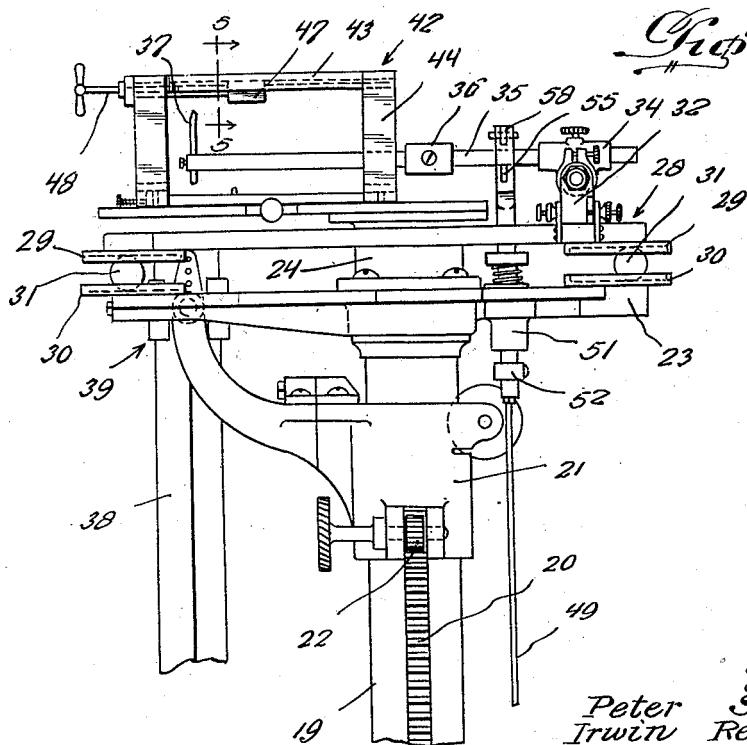

Fig. 3.



Inventors
Peter Sackers,
Irwin Reinhart,
T. G. Straub,

384

Stanley Busch

Attorney

May 10, 1932.

P. SACKERS ET AL

1,857,570

ENGRAVING MACHINE

Filed Dec. 31, 1928

3 Sheets-Sheet 3

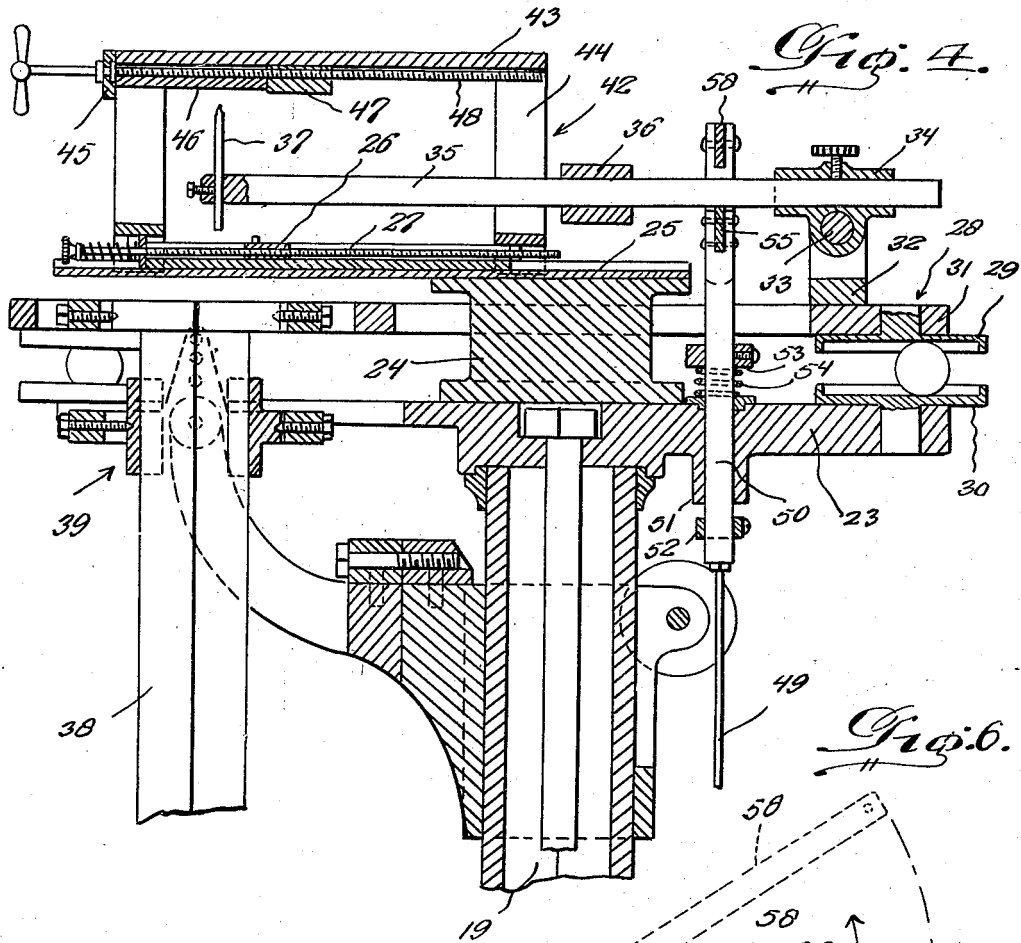

Fig. 7.

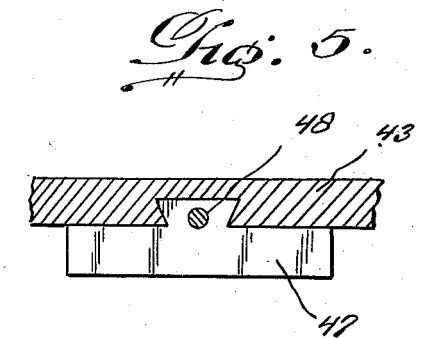

Fig. 5.

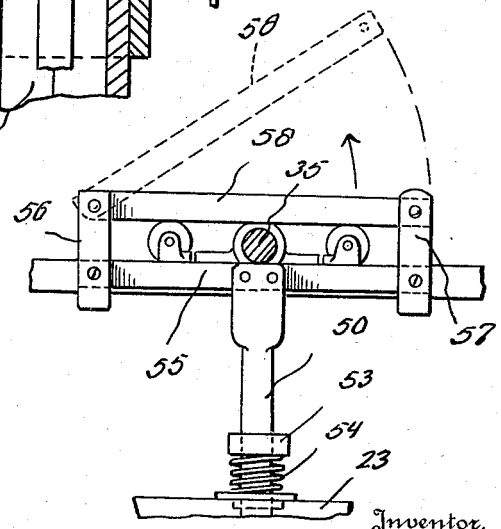

Fig. 6.

Inventor.
Peter Sackers,
Irwin Reinhart,
T. G. Straub,

J. Stanley Birch

Attorney

UNITED STATES PATENT OFFICE

PETER SACKERS, IRWIN REINHART, AND THEODORE G. STRAUB, OF EVANSVILLE,
INDIANA

ENGRAVING MACHINE

Application filed December 31, 1928. Serial No. 329,613.

This invention relates to an improved machine for etching and engraving, and it has more particular reference to a supplemental structure, preferably in the form of an attachment, to be used in connection with marketed engraving, etching and like machines, for instance of the multiplane type.

range-ment and association thereof for accomplishing this advanced and modern idea will become more readily apparent from the following description and drawings; in which

Figure 1 is a front elevational view of an engraving or etching machine embodying the improved attachment and its appurtenances.

Figure 2 is a top plan view, the important part of the ordinary machine being unshaded, and the distinguishable features of the invention being shaded.

Figure 3 is a fragmentary sectional and elevational view showing a close-up of the upper part of the structure, wherein the important features of novelty reside.

Figure 4 is a fragmentary sectional and elevational view showing in greater detail the positions of parts, the section being taken approximately upon the plane of the line 4-4 of Figure 2.

Figure 5 is an enlarged cross section taken approximately upon the plane of the line 5-5 of Figure 3.

Figure 6 is a detail view of the upper portion of the tool arm actuating device, showing the construction of the guide yoke.

Referring now to the drawings by reference numerals, and particularly to Figure 1, it will be seen that 7 designates generally a suitably constructed table on which the master plate or pattern 8 is clamped in the usual way. As before stated, the plate pattern is clamped so that the characters are in reverse-reading order. Hung from the top of the table is a suspension bracket 9 having a bearing at its lower end in which a rock shaft 10 is mounted for oscillation. This shaft is provided with a rocker arm 11 with which a pull link 12 is connected. The link extends down and is in turn connected with an operating pedal 13 arranged in a position to be conveniently actuated by the operator's foot. This pedal is pivoted as at 14 for swinging on a horizontal axis and pivoted again at 15 for swinging laterally on a vertical axis, in order that it may be placed beneath the keeper 16. The pedal is normally urged upwardly by the action of a suitably anchored coil spring 17.

We are aware of the fact that numerous machines of this type have been patented, such as for instance the W. S. Eaton etching machine. Since the present invention is in the form of a supplementary structure and attachment, we have found it convenient to illustrate it as associated with prior Patents 1,039,713 granted to W. S. Eaton under date of October 1, 1912, and 1,603,332 granted to W. S. Eaton under date of October 19, 1928. Reference to these patent, for example, will enable the reader to readily appreciate the improvement embodied in this application, and its advantages as compared to these patented, and similar patented and marketed machines.

So far as we are aware it is a practice in all of such engraving and etching machines to fasten the master plate or pattern on the table in a position wherein the indicia, characters or letters, are in reverse reading order or position. That is, when the operator is standing in front of the table, the characters on the pattern plate face him in reverse.

It follows that it is the principal object here to provide changes in and an attachment for machines of this type so that when the usual reverse-reading pattern plate is placed on the table, the characters will be reproduced in proper reading order. This is done with a view toward enabling unskilled hands to better perform the work in a more dependable and satisfactory manner, and to reduce expense and time and to thereby provide a very economical contribution to the art. However, the use of the reverse-reading work now commonly produced in the trade is not discouraged by our invention. The present invention, therefore, particularly furnishes means providing for an additional use in a thoroughly reliable and efficient manner, as will be hereinafter made apparent.

The particular details, and relative ar-

Rising from and rigidly mounted on the table is a standard 18 including a tubular vertical hollow post 19 equipped with a stationary rack 20. Slidable on the upper portion of the standard is a bracket carrying sleeve 21 (see Fig. 3) having a pinion 22 cooperable with the rack 20.

Referring now to Figure 4 it will be seen that 23 designates a head plate, on top of which is a spacing block 24 to which the customary bed plate 25 is connected. This bed plate embodies, among other parts, the usual work plate clamping element 26 and an operating screw 27 therefor.

Reference character 28 designates generally the movable carriage which is provided on its underside with bearing cups 29 located in alinement with complementary cups 30 on the head plate 23. Anti-friction ball bearings 31 are interposed between and cooperable with these cups. This allows the carriage to move in a horizontal plane underneath the bed plate 25. The carriage is provided with a stationary yoke 32 having a pivot pin 33 on which a coupling 34 is mounted for rocking motion. This part 34 is constructed for adjustable connection of the horizontal tool-carrying arm 35. In order to regulate the sensitivity of balance of this arm, an adjustable counter-balancing weight 36 is provided. Also there is a set screw at the free end of the arm which is employed for clamping the engraving needle, pencil or other scribing tool 37 in operative position. It is to be noted in this connection that the position of this scriber is reversed; that is, it is pointed upwardly. Under normal conditions it would be pointed downwardly for cooperation with a work plate clamped on the bed 25.

The reference character 38 designates a pendulous stylus holder universally supported as at 39 and operatively connected with the carriage 28 in a suitable manner. As shown in Figure 1 this holder 38 is equipped near its bottom with operating handles 40 and with a tracing stylus 41, which obviously cooperates with characters on the pattern 8.

Most of the details so far described are old in the art and shown in the patents mentioned at the outset of the description. We now invite attention to a principal part of the improvement. This is in the form of an attachment generally designated by the reference character 42 in Figure 4. It comprises a horizontal base 43 having supporting legs 44 designed for connection with the bed 25. Incidentally, this part 42 may be permanently mounted or releasably mounted so that it may be removed when desired. The base is provided with a stop 45 and the inverted work plate 46 is clamped between this and an adjustable stop 47. The latter element is operated by an appropriately

mounted feed screw 48. The important distinction to be noted here is that the plate 46 has its work receptive surface or face disposed so that it faces the character surface of the pattern 8. It is thus in proper position for cooperation with the upstanding scriber 37. Still referring to Figure 4 and making additional reference to Figure 6 it will be seen that the means for actuating the arm 35 toward and from the plate 46 also embodies a connecting rod 49, connected at its lower end with a rocker arm on the aforesaid shaft 10 as seen in Figure 1. It is connected at its upper end with a vertical shaft 50 slidable in a bearing 51 on the head 23. Beneath the bearing is an adjustable stop collar 52. Above the head is an adjustable stop collar 53 cooperating with a spring 54 normally tending to slide the shaft 50 upwardly. On the upper end of the shaft is a guide yoke embodying a lower guide arm or crosshead 55 which, as seen in Figure 6, is provided at its opposite ends with upstanding brackets 56 and 57, with which an upper guide arm 58 is cooperable. The arm is pivoted at one end to the bracket 56 and has releasable pin connection at its opposite end with the complementary bracket 57. Obviously this guide yoke is in a position to permit free passage of the arm 35 therethrough. Moreover the upper guide arm 58 can be swung up as shown in dotted lines to release the arm 35.

In order to hold the arm 35 down and disengage the needle-like scriber 37 from the work plate 46, the operator simply presses his foot on the foot pedal 13 and swings it downwardly and then to one side and engages it beneath the keeper 16. Thus the springs 17 and 54 are compressed. However by merely "kicking" the pedal 13 out from beneath the keeper 16, the springs immediately act to rock the shaft 10 and to exert an upward thrust upon the connecting rod 49 and the shaft 50, which, through its operating connection with the arm 35 permits the scriber 37 to move up into operating contact with the work plate 46.

This reversal of parts, as before stated, accomplishes an important result in that it permits the usual pattern 8 to be arranged on the table 7 with its characters in reverse-reading order, but so that such characters are reproduced on the plate 46 directly in normal or natural reading order. Consequently, it eliminates confusion and mistake, and permits efficient operation of the machine by unskilled operators. This therefore reacts to decrease cost of engraving as well as increases efficiency. It permits drawing of exact reproductions of designs directly on paper in one operation to size desired. Instead of showing a sketch or design in reverse, we can show the exact reproduction as it will look when completed.

We have found it possible to cut or en-

grave on copper, steel and other material used in engraving machines, from design, trade-mark, etc., the exact reproduction desired through a direct and nondeceptive method. The arrangement eliminates the laborious methods of making a design in reverse as is necessary to do without the attachment. Finally we do away with the photographic etching method of making the design or sketch which is slow and costly, by substituting the more simple and efficient method of getting the same results in a shorter time and a more direct method. It is thought, however, that persons skilled in the art to which the invention relates will be able to appreciate these advantages and will clearly understand the construction and arrangement after reading the description in conjunction with the drawings. Consequently, a more lengthy description is deemed unnecessary.

Minor changes in shape, size and rearrangement of details coming within the field of invention claimed may be resorted to in actual practice if desired.

What we claim is:

1. A machine of the character described, embodying therein a movable support for a work tool, a work tool carried thereby, a work bed beneath said work tool, a second inverted work bed above said work tool and carried by the first-named work bed, means to impart relative universal movement upon a single plane to said support and said work beds, and members operative upon said support to selectively move it away from either work bed.

2. A machine of the character described, embodying therein a movable support for a work tool, a work tool carried thereby, a work bed beneath said work tool, a second inverted work bed above said work tool and carried by the first-named work bed, means to impart relative universal movement upon a single plane to said support and said work beds, and members operative upon said support to selectively move it away from either work bed, and yieldable means for actuating said member whereby said support may be selectively caused to normally move toward either desired work bed to bring the work tool into operative engagement with the work.

3. A machine of the character described, embodying therein a movable support for a work tool, a work tool carried thereby, a work bed above said work tool, means adapted to impart relative universal movement upon a single plane to said support and said work bed, a member manually operative upon said support to move it downwardly away from said work bed, yieldable means to normally urge said member upwardly away from said support and to simultaneously move said support upwardly to bring said work tool

into operative engagement with work on the under side of said work bed, and means to releasably hold said member in its downward position to retain the support away from said work bed.

4. An attachment for a machine of the character described, wherein a movable support for a work tool is arranged above a work bed, wherein means is provided to impart relative universal movement upon a single plane to said support and said work bed, wherein a member is manually operative upon said support to move it upwardly away from said work bed, and wherein means is provided to move said member downwardly away from said support to permit the latter to descend toward the work bed and bring the work tool into operative engagement with work on the upper surface of said work bed, said attachment comprising a second work bed having means to mount the same on the first named work bed above the work tool support and means on said second bed to secure work on the under side thereof for engagement by the work tool of said support when the latter is moved upwardly.

5. An attachment for a machine of the character described, wherein a movable support for a work tool is arranged above a work bed, wherein means is provided to impart relative universal movement upon a single plane to said support and said work bed, wherein a member is manually operative upon said support to move it upwardly away from said work bed, and wherein means is provided to move said member downwardly away from said support to permit the latter to descend toward the work bed and bring the work tool into operative engagement with work on the upper surface of said work bed, said attachment comprising a second work bed having means to mount the same on the first named work bed above the work tool support and provided with means to secure work on the under side thereof for engagement by the work tool of said support when the latter is moved upwardly, and a second member connected to said first-named member and operative upon said support to move it downwardly away from said second work bed when the first-named member is moved downwardly.

6. An attachment for a machine of the character described, wherein a movable support for a work tool is arranged above a work bed, wherein means is provided to impart relative universal movement upon a single plane to said support and said work bed, wherein a member is manually operative upon said support to move it upwardly away from said work bed, and wherein means is provided to move said member downwardly away from said support to permit the latter to descend toward the work bed and bring the work tool into operative engagement with

work on the upper surface of said work bed,
said attachment comprising a second work
bed having means to mount the same on the
first named work bed above the work tool sup-
port and provided with means to secure work
5 on the under side thereof for engagement by
the work tool of said support when the latter
is moved upwardly, and a second member
connected to said first-named member and
operative upon said support to move it down-
10 wardly away from said second work bed
when the first named member is moved down-
wardly, and means to render said further
member operative or inoperative, at will.

15 7. An attachment for a machine of the
character described, wherein a movable sup-
port for a work tool is arranged above a work
bed, wherein means is provided to impart
relative universal movement upon a single
20 plane to said support and said work bed,
wherein a member is manually operative
upon said support to move it upwardly
away from said work bed, and wherein
means is provided to move said mem-
25 ber downwardly away from said support to
permit the latter to descend toward the work
bed and bring the work tool into operative
engagement with work on the upper surface
of said work bed, said attachment comprising
30 a second work bed having means to mount the
same on the first named work bed above the
work tool support and provided with means
to secure work on the under side thereof for
engagement by the work tool of said support
35 when the latter is moved upwardly, a second
member connected to said first-named mem-
ber and operative upon said support to move
it downwardly away from said second work
bed when the first named member is moved
40 downwardly, and means to releasably hold
said members in a downward position.

In testimony whereof we affix our signa-
tures.

45 PETER SACKERS.
IRWIN REINHART.
THEODORE G. STRAUB.

50

55

60

65