

**The
Typographical
Journal**

Official Paper of the International Typographical Union
of North America.

Vol. IX.

October 1, 1896.

No. 7.

**AMERICAN
TYPE FOUNDERS
COMPANY**

- Boston
- New York
- Philadelphia
- Baltimore
- Buffalo
- Pittsburgh
- Cleveland
- Cincinnati
- Chicago
- Milwaukee
- St. Louis
- Minneapolis
- Kansas City
- Omaha
- Denver
- Portland (Ore.)
- San Francisco

MAKERS OF THE BEST TYPE



THE TYPEFOUNDER'S ART.

A Bit of Its History, Ancient and Modern, and a Detailed Technical Description of the Methods and Machines Used in Casting Type.

BY SKOPEO, OF NO. SIX.



AFTER the procedure described in the last issue of the JOURNAL, the drive is taken to a fitter, whose work it is to complete the matrix (Fig. 3). The fitter

must file away the copper until he gets a distance from the top of the sunken letter in the copper and its top and side edges uniform with that on all other matrices in the font he is fitting. The distance from the top edge gives the line of the type and the distance from the side gives the spacing or position of the type width-wise (or set wise, as a typefounder would say) in relation to other letters of the font. The beauty of a face depends very largely on the judgment of the fitter in spacing the letters. The workman then files away the face of the copper drive until the sunken letter has a uniform depth at all points from the face of the copper. Any inaccuracy in this operation would make one part of the face higher or lower than another, and would result in type that would not give an even impression.

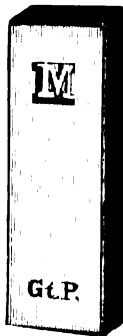

Fig. 3.

matrix from the punch, which can only be used once, while a steel punch can be used indefinitely. There is also greater labor in fitting an electro-matrix. But this process has, I learn, become very common, as it saves considerable expense in cutting in steel.

The preparatory work having been done, a trial cast from a hand mold is taken and a proof is printed. This proof is read by an expert with the aid of a magnifying glass, and the tedious work of correcting any imperfections of the face, line, distance and depth is begun. The care with which this work is done depends on the conscientiousness of the typefounder, and the value of the product to the printer is enhanced or depreciated by the care or want of care given to expensive details on the part of the manufacturers, and for this reason those concerns with long-established reputations to maintain are considered by those who buy type as the safest to deal with. The character of the maker, it will be noted, has a great deal to do with the quality of the type.

The finished matrices are taken to the type-casting department, which is provided with molds (Fig. 4) for every body used. The illustration shows a great primer mold, open, with a type in it; no other size can be cast in it, but the width or set of the various letters of a font can

be changed by means of the screws. The mold determines the body and the nick of the type, and on its accuracy depends that of body and squareness of the type. It is made of hardened steel, in two parts, each part containing numerous pieces.

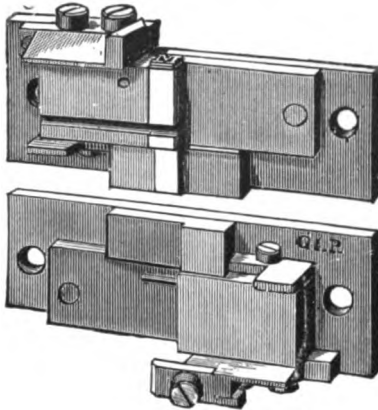

Fig. 4.

The mold maker must be a man of the highest skill, and all his measurements are made to the ten-thousandth part of an inch. The tension of work of this nature may faintly be imagined. Molds are very expensive, and require constant watching and overhauling, as the most infinitesimal wear of one of them affects the body of the type.

The mold and the matrix are next secured to the casting machine (Fig. 5), which consists of a metal pot, beneath which is a furnace; a pump, which ejects the metal through a small orifice in the metal pot (called the nipple); and mechanisms for holding the mold and matrix, for opening the mold so that the cast type may be ejected, and a receiver or box for the type. One part of the mold is fastened to the casting machine and is stationary; the other half is movable. When the mold is closed the matrix is fastened so that the letter in it is immediately opposite the opening in the mold which corresponds to the body to be cast (see M in Fig. 4). The metal is injected from the bottom of the letter. When the letter is cast it lies in the mold, as shown in Figs. 4 and 6, and has a wedge-shaped projection on the bottom called the jet.

When the type is ejected the mold closes automatically and returns for another cast. The process is slow, and is affected by the condition of the temperature, draughts, and metals, and requires the utmost vigilance on the part of the type-casters, with constant supervision and measurements by the foremen. The speed of casting depends on the size of the type, the largest type requiring the longest time to cast.

Fig. 5 shows the type-casting machine in common use in the United States and Europe. It is the invention of the late David Bruce, who perfected it in 1840, up to which time type was cast in hand molds. Mr. Bruce played a very important part in the business. The illustration shows a hand-casting machine. All large type are cast by hand, but steam-casters are used on smaller sizes. The Bruce machine occupies the field almost wholly, the exception being an invention of recent years (Fig. 6) which casts type auto-

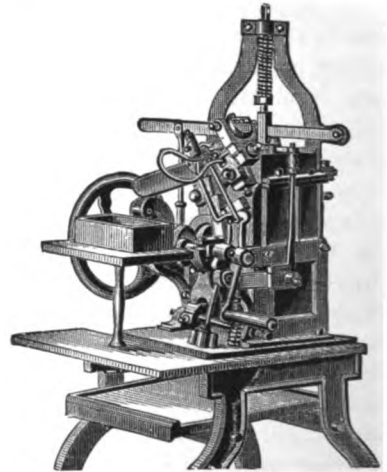

Fig. 5.

matically and saves many hand processes, hereafter to be described, which are necessary on the old-style machines. The automatic type-casting machine is the invention of Henry Barth of Cincinnati. This machine is a marvel of effective ingenuity and accuracy. It not only casts type with a greater rapidity, but it breaks, rubs, dresses and sets the type, and delivers it ready for examination and pag-

ing. It will be noted that the three great inventions in use in the best modern foundries, the Benton punch-cutter, the Bruce type-caster, and the Barth automatic type-caster, are inventions of citizens of the United States. Mr. Bruce

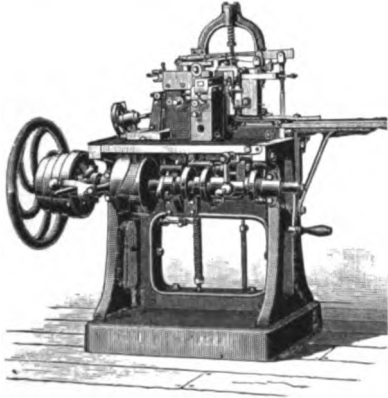

Fig. 6.

died in 1893, and Messrs. Benton and Barth are in the prime of life, the recognized masters of their art.

Fig. 7 shows the type with a jet on it as it leaves the hand-casting machine. This jet is broken off by hand by a boy or girl, known as a "breaker." It is then passed to the "rubber," who removes a slight bur at the edges by carefully rubbing the sides of the type on a special stone or over very fine files. The type then goes to the "setters," who set the type on long setting sticks about two feet in length, nick out and face up. The loaded sticks go to the "dresser," whose duty it is to examine the type by means of a powerful magnifying glass, discard all imperfect letters, rub the body sides of the type with a fine scraper and cut the groove in the bottom (Fig. 8) with a grooving plane. He then



Fig. 7.

pages up the type in lines six inches long, ties it with cord, wraps it in paper and labels it, if it is body type; but if it is job type he passes it to the "divider," who carefully counts and assort the number of each letter required to complete the font, and pages and labels each



Fig. 8.

font. A font of body type as it leaves the dresser's hands seldom weighs less than six hundred pounds. This font is afterward subdivided by the dividers into fonts weighing twenty-five, fifty and one hundred pounds and upward, according to the demand. Italic, script and letters which overhang the body are kerned by a kerning machine which dresses the body so that it will not interfere with spaces or leads when in use.

The operations of breaking, rubbing, setting and grooving are done automatically by the Barth machine after it leaves the mold. Many steam casting machines are provided with automatic breakers, the patents for which are owned by two type foundries.

It may enlighten the printer who orders sorts and wonders why he has to wait for them if the reason is explained. Sorts are almost always made to order. When the order for a few sorts reaches a foundry it has left the order clerk and goes to the foreman, who enters it and passes it to the keeper of the matrix vault, who hands it to the caster, who casts it (having often to lift a steady run on a large font to do so) and passes it to the breaker, who gives it to the rubber, who hands it to the dresser, who returns it to the foreman for examination, after which it is delivered to the shipper in the salesroom. Thus eight people have handled (some of them twice) a small order for which a charge of a few cents only is made. The casting of sorts is one of the greatest accommodations the typefounder gives the printer, as a large number of such orders are filled at a loss, and this without taking into account the obstruction and delay to regular work.

Quotation furniture is cast by hand in molds, and so also is metal furniture, the latter being afterward planed to size. Leads and slugs are cast in hand molds, usually in gangs, and afterward shaved down to size.

When the difficult, expensive and tedious process of making type and the great

cost of presenting the specimens of it to the trade are understood, printers may well wonder that the price is so low. Although the wages paid to employes in type foundries in the United States range from three to four times higher than in Great Britain and Europe, type made here is sold at about the same net prices as in Europe. This is largely due to the improvement in machines and processes used in American typefoundries, the most of which are used exclusively here.

The faces of job type cast in the United States are clearer than those of the old world, a fact which doubtless adds its

quota to the reputation our jobbers have gained of surpassing their brethren on the other side of the water in this branch of printing. There is no boastfulness in asserting that we lead the world in every department of printing. Let anyone interested in this matter compare advertisements set here and used, say, in a high-class trade paper, with those printed in similar journals in either Great Britain or the continent and he will be at once convinced. Both type and display will be found in the van. Of course much of this excellence is due to the better press-work done in the United States.

THE SINGLE-TAX THEORY.

Non-Access to Natural Opportunities a Hinderance to its Presentation with the Other Industrial Issues of the Day—Reply to "A Printer's Wife."

BY CHARLES H. KOHLMAN, ST. PAUL, MINN.

Since the appearance in THE TYPOGRAPHICAL JOURNAL of the article of Mrs. Frances Eldridge Russell, over the signature of "A Printer's Wife," I have frequently been asked to write an article showing how the single-tax would secure to the worker the full products of his toil. Although this letter was published over a year ago, Mrs. Russell has of late contributed a series of articles in the Arena magazine in which she reiterates her former opinions and contends that the single-tax will not do what its advocates claim for it, and that, of itself, it will not prove a solution of the labor problem. The great inventions in labor-saving machinery of the past fifty years, and the consequent subdivision of labor, she contends, have had the effect of precluding the securing by the worker of the full result of his toil by any other method save state supervision of all industries. She makes a lengthy argument in support of her position, but makes an admission which, it seems to

me, knocks the foundation from under her entire structure. She admits that under the single-tax there would be work for all.

Now, the reason that men will work for an employer today for less than they ought to receive is because they are shut off from natural opportunities for self-employment, and consequently are compelled to bid against each other for the privilege of working. Is it not perfectly plain that where the avenues for self-employment are open to all alike no man will work for another unless by so doing he can earn more than if he worked for himself? A very little reflection, it seems to me, will show that such is the case.

In cases of strikes it is always the unemployed who take the places of the disgruntled workmen and reduce wages and the standard of living. As long as men have a job which assures them of even a hand-to-mouth existence, they will not take the places of other men who are seeking to better their condition.