

D. Bruce, Jr.

Mach. for Smoothing Type.

No 5483.

Patented Mar. 28. 1848.

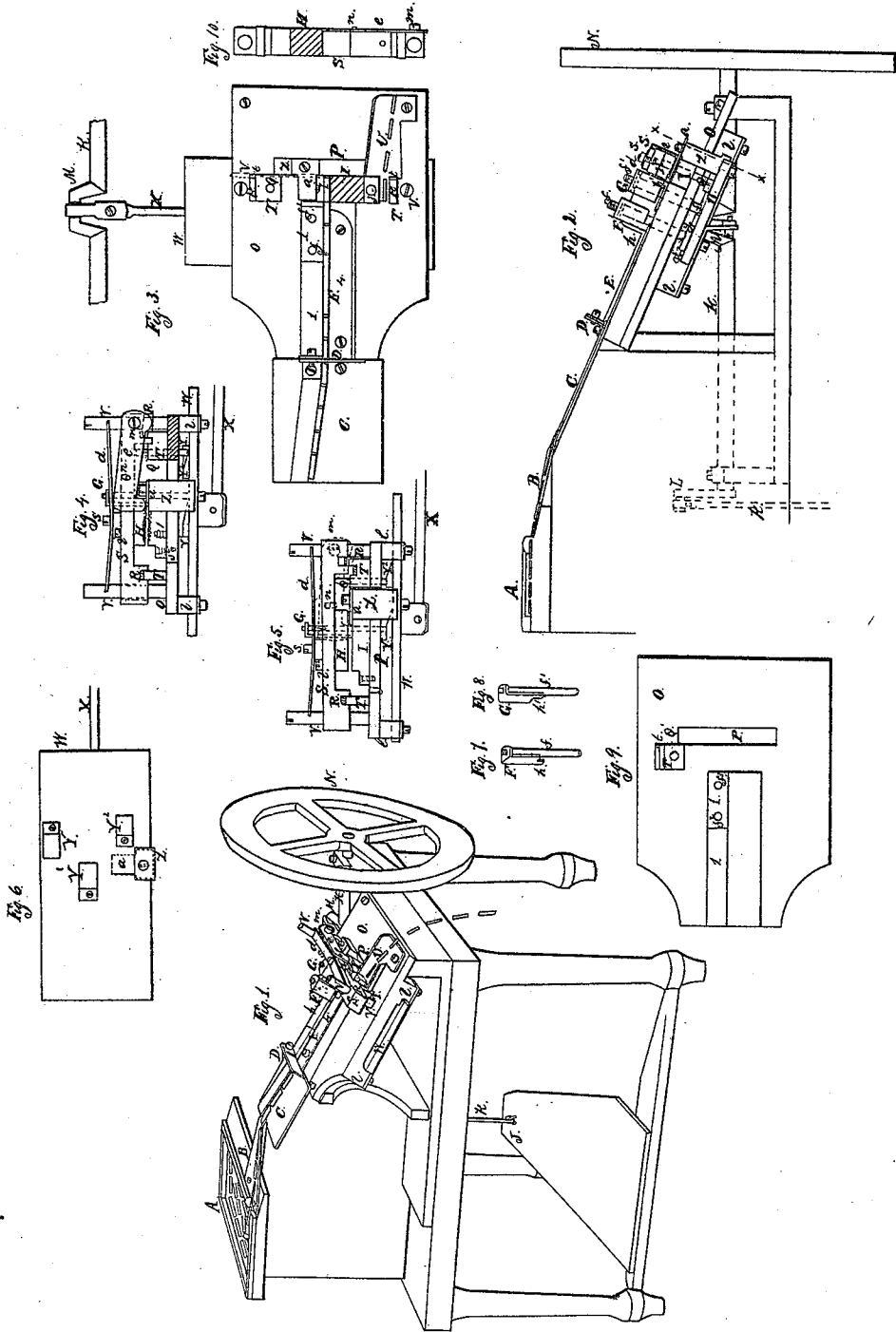

# UNITED STATES PATENT OFFICE.

DAVID BRUCE, JR., OF WILLIAMSBURG, NEW YORK.

## IMPROVEMENT IN TYPE-SMOOTHING MACHINES.

Specification forming part of Letters Patent No. 5,483, dated March 28, 1848.

*To all whom it may concern:*

Be it known that I, DAVID BRUCE, JR., of Williamsburg, Long Island, in the county of Kings and State of New York, have invented new and useful Improvements in Machines for Smoothing the Sides of Type, which are described as follows, reference being had to the annexed drawings of the same, making part of this specification.

Figure 1 is a perspective view of the machine. Fig. 2 is a vertical longitudinal section through a part of the same, showing the shaft K, plate-crank M, and balance or fly wheel N. Fig. 3 is a top or bird's-eye view of the inclined guide-plate, inclined plate *o*, gutter E, lower cutter I, with the openings through the inclined plate, in which the stems of the stops F G and the pin Q work and stud Z traverses. Fig. 4 is a transverse section through the inclined plate, alternating plate, and other parts of the machine at the line *x* *x* of Fig. 2, the stud Z and pusher *a* being represented as advancing with a type between the cutters. Fig. 5 is likewise a transverse section at the line *x* *x* of Fig. 2, the stud and pusher in this section being represented in the position they will assume in relation to the cutters when the crank is at half-stroke, the lower stop G and cutter H being up and latch *e* down. Fig. 6 is a top view of the alternating plate, showing the inclined planes and pusher on the surface of the same. Fig. 7 is a perspective view of the upper stop and its sliding stem, to which it is fastened. Fig. 8 is a perspective view of the lower stop and its stem. Fig. 9 is a top view of the inclined plate *o* detached. Fig. 10 is a view of the under side of the upper cutter in an inverted position.

Similar letters in the several figures refer to corresponding parts.

In this machine I have adopted the usual manner of former attempts of feeding the machine with type by the left hand from an upper shelf A and by the influence of gravity allowing them to descend first over the distributor B, thence over the guide-plate C, passing under the gate D, through the gutter E to the stops F G, whose office is to regulate their passage between the steel cutters, and, being pushed through them sidewise, are discharged at the spout U. Motion is given to

all working parts of the machine, hereinafter to be described, by the foot applied to the treadle J.

As many of the parts of this machine are constructed, arranged, and operated in the usual manner, they will not be particularly described, but merely referred to by letters to show their connection with the parts claimed as new.

A is the shelf on which the type is placed to feed the machine, arranged at a higher elevation than the other parts.

B is the distributor.

C is the guide-plate.

D is the gate under which the type pass in their descent to the cutters.

E is the gutter formed between plates 1 4 on the upper surface of the inclined plate O, the plate 4 being adjustable.

F is the upper stop, consisting of a small plate of metal arranged on the side of a casting 1, secured on the inclined plate, having a small cog *h* on its lower end, and bent over the top of the same at right angles and secured at its upper end to a stem *f*, passing through an opening in said casting and inclined plate at right angles to the upper surface of said plate, and extending below the same to the surface of the alternating plate.

G is the lower stop, arranged below the upper stop on the line of the gutter, and secured to a stem *f'*, passing through an opening *f*<sup>3</sup> in the casting 1 and inclined plate O, and made and arranged in every respect like the upper stop F, except that the cog *h'* on its lower end is formed next its lower edge, while the cog on the upper stop F is formed next the upper edge of said stop, as represented in Fig 2.

H is the upper cutter, attached to the metallic bar S by screws *i*, the teeth of which cross the teeth of the lower cutter obliquely.

I is the lower cutter, secured to the inclined plate by screws *j*. Both cutters are made of steel, like a file.

J is the treadle for operating the machine.

K is the horizontal crank-shaft.

L is the crank on the end of the same, connected to the treadle by a rod *l*.

M is the alternating-plate crank.

N is the fly or balance wheel.

O is the inclined metallic plate to which the

lower cutter is secured, containing a transverse oblong slot P near its lower end adjoining the lower cutter.

Q is a pin or stem passing through an opening in one of the rests T and the inclined plate O and resting on the alternating plate W at its lower end.

S is the metallic bar, to the lower surface of which the upper cutter is secured and resting upon the head of pin Q.

T T are the rests (containing the gage-types) secured to the surface of the inclined plate O immediately under the metallic bar S in the usual or most approved manner.

R R are gage-types arranged between the rests T T and lower edge of the metallic bar S, for regulating the space between the cutters.

U is the spout through which the types are discharged from the machine.

V are studs rising from the surface of the inclined plate at right angles and passing through openings in the ends of the metallic bar S.

W is the alternating plate, attached by a connecting-rod X to the crank M, from whence it derives its movement, and moving in slots formed in projections *l* on the under side of the inclined plate O.

Y Y' Y<sup>2</sup> are inclined planes on the upper surface of the alternating plate, arranged in such relation to each other and to the lower ends of the stems *f f'* and pin or stem Q as to cause them to rise and fall with the stops F G and upper cutter H in their respective order. Y acts on stem *f*, Y' on stem *f'*, and Y<sup>2</sup> on stem Q.

Z is a stud secured to the alternating plate and passing up through the inclined plate O, its upper end being in a line with the upper surface of the lower cutter I and the gutter E and alternating with the plate W through the oblong slot P in the inclined plate O. To this stud Z is secured the type-pusher *a*, Figs. 1, 2, 3, 4, and 5. This pusher *a* is made of a strip of brass or other suitable metal, somewhat thinner than the type intended to be pushed between the cutters H and I.

*d* is a spring whose ends fit into notches in the studs V V, and secured at its center to the bar S by the screw *s*. The office of the spring *d* is to press the upper cutter H with sufficient force downward toward the lower cutter to remove the roughness of the type intended to be passed between them.

Attached to the bar S and parallel to its length is seen the latch *e*, Figs. 1, 2, and 4. This latch is hinged to one end of the bar S by a screw *m*. The other end is secured to the bar by another screw passing through a slot *n* in the latch. The office of this latch is to act as a lower stop to the type to prevent it from escaping through the cutters before the pusher *a* is ready to receive it. This latch alternately rises and falls by the passage of the pusher under it.

The rests T T are for the purpose of re-

taining the two gage-types R R, which are placed between them and the bar S to set the cutters III a proper distance apart. The gage-types are held upon these rests by small projections or ribs *l*, formed on the upper surfaces of the rests. The gage-types must be of the same thickness to which the type are to be dressed, changeable at pleasure.

Having described the various sectional parts, I will now describe their combined operation when in motion. As stated before, motion is given to the treadle J by the action of the foot. The machine being set in motion and a stream of type being allowed to descend and fill the gutter E, the upper stop F rises by action of the inclined plane Y, as before described, and allows the stream of type to descend about the distance of the length of a type and a half, which brings the lowest type in contact with the next stop G, which, being down, holds the stream from further descent until the pusher *a* in its backward course is past the line of the gutter E. The pusher *a* having passed the line of the gutter E and allowed the latch *e* to drop to its place, and thereby act as a lower stop to the type, and the upper cutter being raised by the pin Q, pressing upward the bar S, and the stop G rising simultaneously with it by the two inclined planes Y' Y<sup>2</sup>, and the upper stop F having dropped (by the passage of its inclined plane Y) on the last type but one in the gutter from the bottom, the stream of type is held back and the lower type slides downward into its position upon the lower cutter I being arrested from further descent by the latch *e*. The pusher *a* now comes forward on its return to push along the type between the cutters; but just as it reaches the type the upper cutter H descends (being relieved by the descent of the pin Q) by the action of the spring *d*, and presses the type firmly between the two cutters. The pusher *a*, continuing its course, pushes the type sidewise through the cutters to their termination, whence it escapes down through the spout U into a receiving-box. During the forward movement of the type and pusher the upper stop F rises and allows the stream of type to descend, as before described, until it is arrested by the stop G, the returning or backward motion of the pusher acting simultaneously with the descending of the upper stop F, rising of the lower stop G, the elevating of the upper cutter H, and the introduction of a single type into the cutters, and the stopping of the stream of type being all performed by the alternating movement of the plate W, the three inclined planes Y Y' Y<sup>2</sup>, and stud Z thereunto attached.

To give a sufficient portion of time for the introduction of a type between the cutters, the pusher *a* has to pass as far over on the blank side of the line of the gutter E as on the one containing the cutters. Consequently the crank M, which gives motion to the plate W, has to be proportionally longer to produce

this effect. By observing a proper attention to an adjustment of these few movements connected with the alternating plate and making the whole work in harmony an average speed of an ordinary hand will be about eighty per minute. One more skilled would pass through about one hundred.

In this machine I do not claim the method of forwarding the type to the cutters by a gradual inclination of the type from a higher elevation gravitating downward, as before described, nor the gate D, the pusher  $a$ , the seats for the gage-type R R, the plan of timing the descent of the type by stops, nor the lifting of the upper cutter, these having been used in numerous attempts of myself and others in the construction of type-smoothing machines heretofore; but

What I do claim as my invention and as original in the machine for smoothing the sides of type, and for which I ask Letters Patent, is—

1. The combination of the alternating plate W, inclined planes Y Y' Y<sup>2</sup>, pusher  $a$ , and stud Z, made and arranged substantially as above described, said plate W sliding beneath the

inclined plate O parallel to the cutters, for the purpose of raising the stops F G, pin Q, and carrying the stud Z with its pusher-arm  $a$ , in the manner and for the purpose above set forth.

2. Making the inclined plate O with the passages  $f^2 f^3$  Q' P through the same, for the traverse of the stems  $f f'$ , pin Q, and stud Z, as described.

3. The combination of the stems  $f f'$  with the stops F G, said stems passing down through the inclined plate O and acted upon by the inclined planes Y Y' Y<sup>2</sup>.

4. The combination of the latch  $e$  with the cutter-bar S, said latch  $e$  acting as a lower stop to the type and being raised by the pusher  $a$  in its traverse motion to the right and left underneath it.

5. The combination of the piston Q with the inclined plane Y<sup>2</sup>, for lifting the upper cutter, as described.

DAVID BRUCE, JR.

Witnesses:

LEONARD T. COLES,  
CHARLES B. HOLMES.