



This is a digital copy of a book that was preserved for generations on library shelves before it was carefully scanned by Google as part of a project to make the world's books discoverable online.

It has survived long enough for the copyright to expire and the book to enter the public domain. A public domain book is one that was never subject to copyright or whose legal copyright term has expired. Whether a book is in the public domain may vary country to country. Public domain books are our gateways to the past, representing a wealth of history, culture and knowledge that's often difficult to discover.

Marks, notations and other marginalia present in the original volume will appear in this file - a reminder of this book's long journey from the publisher to a library and finally to you.

Usage guidelines

Google is proud to partner with libraries to digitize public domain materials and make them widely accessible. Public domain books belong to the public and we are merely their custodians. Nevertheless, this work is expensive, so in order to keep providing this resource, we have taken steps to prevent abuse by commercial parties, including placing technical restrictions on automated querying.

We also ask that you:

- + *Make non-commercial use of the files* We designed Google Book Search for use by individuals, and we request that you use these files for personal, non-commercial purposes.
- + *Refrain from automated querying* Do not send automated queries of any sort to Google's system: If you are conducting research on machine translation, optical character recognition or other areas where access to a large amount of text is helpful, please contact us. We encourage the use of public domain materials for these purposes and may be able to help.
- + *Maintain attribution* The Google "watermark" you see on each file is essential for informing people about this project and helping them find additional materials through Google Book Search. Please do not remove it.
- + *Keep it legal* Whatever your use, remember that you are responsible for ensuring that what you are doing is legal. Do not assume that just because we believe a book is in the public domain for users in the United States, that the work is also in the public domain for users in other countries. Whether a book is still in copyright varies from country to country, and we can't offer guidance on whether any specific use of any specific book is allowed. Please do not assume that a book's appearance in Google Book Search means it can be used in any manner anywhere in the world. Copyright infringement liability can be quite severe.

About Google Book Search

Google's mission is to organize the world's information and to make it universally accessible and useful. Google Book Search helps readers discover the world's books while helping authors and publishers reach new audiences. You can search through the full text of this book on the web at <http://books.google.com/>



3 3433 00634831 6

1100
117

The Elsie Robinson - Florheimer
Typographical Collection



Given by the Carl and Lily
Florheimer Foundation, Inc.

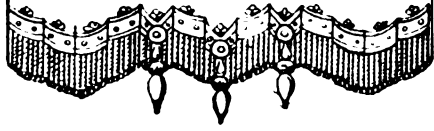

THIS BOOK OF TYPE SPECIMENS
AND PRINTING INFORMATION IS
FOR THE PRINTERS' DESK—FOR
DAILY USE AND FOR REFERENCE



DESK
BOOK

Specimens of Type
Borders & Ornaments
Brass Rules & Electrotypes



Catalogue of Printing Machinery
and Materials, Wood Goods, etc.



... **American** ...
Type Founders Company

Everything for the Printer
1898



ST. LOUIS



NEW YORK

Manufacturing
Foundries of
**American
Type
Founders
Company**



PHILADELPHIA



BOSTON



CHICAGO



CINCINNATI

TO THE PRINTER:

THE Type and Borders shown in this specimen book excel in design—the chief merit of type—and their durability is as-

sured by the use of the celebrated Copper Alloy Type Metal ❖ ❖ ❖ ❖ ❖ ❖ ❖ ❖ ❖

❖ The selection of styles of Type illustrated in this book excels in both variety and utility the combined product of all other type foundries ❖ ❖ ❖ ❖ ❖ ❖ ❖ ❖ ❖

❖ A printing office completely supplied with the products of this Company is worth far more for either use or sale than one made up from the productions of incomplete type foundries ❖ ❖ ❖ ❖ ❖ ❖ ❖ ❖ ❖

❖ It is conceded that the Type made by this Company is the standard for excellence throughout the world. Every endeavor is made to advance that standard ❖ ❖ ❖ ❖ ❖ ❖ ❖ ❖ ❖

❖ As the largest purchaser of Printing Machinery and Materials in the world, this Company commands the best of everything for the printer, and has unsurpassed facilities for meeting the requirements of printing offices ❖ ❖ ❖ ❖ ❖ ❖ ❖ ❖ ❖

AMERICAN TYPE
FOUNDERS COMPANY

A. D. 1898



American Type Founders Co.

Branches



Covering
the Entire
Continent

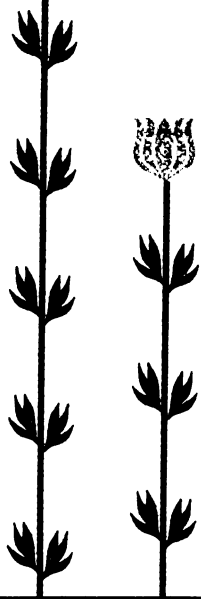

- ST. LOUIS**
Fourth and Elm Streets
- CINCINNATI**
7-13 Longworth Street
- KANSAS CITY**
612 Delaware Street
- CLEVELAND**
St. Clair and Ontario Sts.
- CHICAGO**
203-205 E. Monroe Street
- MINNEAPOLIS**
24-26 First Street, South
- DENVER**
1616-1622 Blake Street
- PORTLAND, ORE.**
Second and Stark Streets
- SPOKANE**
10 Monroe Street
- SAN FRANCISCO**
405-407 Sansome Street
- LOS ANGELES**
211 New High Street
- PITTSBURGH**
323 Third Avenue
- BUFFALO**
45 N. Division St.. cor. Ellcott
- BALTIMORE**
Frederick and Water Streets
- PHILADELPHIA**
606-614 Sansom Street
- NEW YORK**
Rose and Duane Streets
- BOSTON**
270 Congress Street



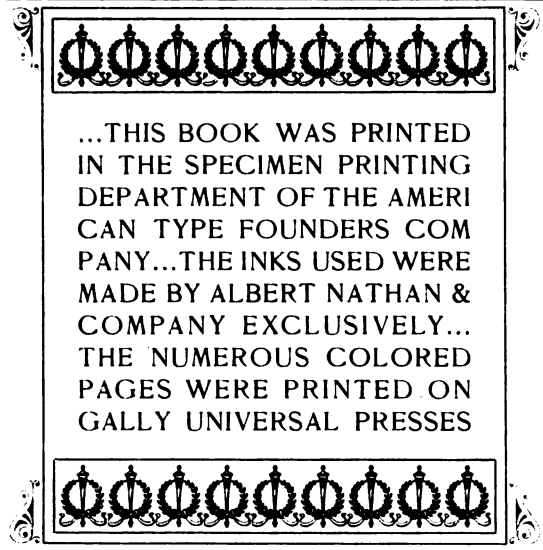

...THIS BOOK WAS PRINTED
IN THE SPECIMEN PRINTING
DEPARTMENT OF THE AMERI
CAN TYPE FOUNDERS COM
PANY...THE INKS USED WERE
MADE BY ALBERT NATHAN &
COMPANY EXCLUSIVELY...
THE NUMEROUS COLORED
PAGES WERE PRINTED ON
GALLY UNIVERSAL PRESSES



Five Highest Awards
COLUMBIAN EXPOSITION

CHICAGO, 1893



FOR Exhibition of Machinery, Appliances and Processes for the Manufacture of Movable Metal Type, beginning with the perfectly constructed and minutely adjusted Benton Punch-Cutting Machine, and ending with the well-designed and highly efficient Barth Automatic Steam-Power Type-Casting and Type-Finishing Machine, in the production of Copper Alloy Type of the correct proportions of Toughness, Hardness, Uniform Accuracy and High Degree of Utility.

INDEX TO TYPE SPECIMENS

	PAGE		PAGE
Accented Letters	51	Black Fists	575
Acorn Initials	588	Black No. 12	440
Advertising Rules	33	Boldface No. 114	186
Alaskan	380	Boldface No. 120	186
Alfereta	498	Boldface Italic No. 120	188
Algebraic Signs	46	BORDERS:	
Alpine	368	—Art	613-617, 632
American Old Style	376	—Barta	610, 611
American Old Style No. 3	348	—Barth Geometrical	637
American Press Association Series No. 61	62, 105	—Brier	631
American Script	456, 457	—Caxton	606
Anglo-Saxon No. 20	441	—Collins	611
Angular Quads	37	—Comb. Series 98	640, 641
Antique No. 42	201	—Contour	608, 609
Antique No. 124	201	—Daisy	633
Antique No. 125	202	—Darling	633
Antique No. 126	203	—Eighteen Point No. 27	605
Antique No. 127	206	—Elzevir	606
Antique Cond. No. 116	207	—Empire	636
Antique Cond. No. 122	206, 207	—End-wood	795
Antique Cond. No. 123	209	—Flag	639
Antique Cond. No. 124	210	—Flame	618
Antique Cond. No. 152	206	—Floral	631
Antique Ex. Cond. No. 150	208	—Florentine	607
Antique Extd. No. 40	213	—Half-Nonpareil	625
Antique Extd. No. 120	213	—Holly	631
Antique Extd. No. 122	214	—Klondike	638
Antique Extd. No. 123	212	—Laurel	634
Antique Extd. No. 124	214	—Manila	595
Antique Extd. No. 152	212	—Myrtle	639
Antique Extd. No. 153	212	—Newspaper	605, 619-623
Antique Fractions	569	—Nonpareil	626, 627
Antique Pointed No. 120	224	—Nonpareil and One-Half	628
Apollo	497	—Pica	628, 629
Apple Blossom Ornaments	593	—Pointer	633
Arboret	513	—Polka-Dot	632
Archaic	392, 393	—Red, White and Blue	602
Argent	518	—Regal	633
Arithmetical Signs	46	—Rococo	605
Arlington	398, 399	—Rustic Band	632
Armenian	553	—Thirty Point No. 1	605
Army and Navy	743	—Three-line Nonpareil	630
Arrows	565	—Three-line Pica	630
Art Borders	613-617, 632	—Twelve Point	624
Art Gothic	363	—Twenty-four Point	624
Art Initials	585	—Two-line Pica	630
Astronomical Signs	47, 48	—Union	603
Atlanta	378	—Wood	795
Augustan Text	441	Boston Black	445
Autograph Script	477	Boston Script	454, 455
Ballet Dancers	648	Bowlers	646
Barta Borders	610, 611	Braces	35, 50
Barth Geometrical Borders	637	Bradley	428, 429, 433
Barth Old Style	120, 121	Bradley Extended	424-427
Baseball, Series 1	651	Bradley Initials	429, 586
Beavers	567	Bradley Italic	430, 431
Billhead Logotypes	576	Bradley Outline	432, 433
Binner	324-326, 435	Brass Braces	35
Binner Gothic	281	Brass Circles	30, 31
Binner Open	327, 435	Brass Column Rules	32
Black Cap	377	Brass Dashes	34
		Brass Dash Rules	33
		Brass Diamonds	31
		Brass Head Rules	33
		Brass Leaders	35
		Brass Leads and Slugs	32
		Brass Ovals	31
		Brass Rules, Labor-Saving	28, 29
		Brass Rules, Strips	17-27
		Brass Scoring Rules	27
		Brass Space Rule	27
		Brass Type	16
		Breton	211
		Brier Border	631
		Broadgauge	215
		Broadgauge Ornate	520
		Caledonian Fractions	569
		Calendar Figures	570, 571
		Calendar Logotypes	572-574
		Caligraph	508
		Campaigners	648
		Cancelled Figures	49
		Card Indicators	565
		Card Pips	565
		Carpenter Script	469
		Caslon Condensed	349
		Caslon Old Style	127-131
		Caslon Old Style Italic	131, 132
		Cast Cuts	689
		Cast Initials	585-587
		Caxton Black	436, 437
		Caxton Bold	170, 171
		Caxton Borders	606
		Caxton Old Style	150-153
		Caxton Old Style Italic	150, 151
		Celtic No. 3	239
		Central Antique	204
		Central Bands	632
		Central Ornaments	591, 592
		Century Roman	108, 109
		Chamfer Condensed	250, 251
		Check Blanks	577
		Checkers	564
		Chelsea Circular	500
		Chessmen	564
		Chicago Script	490
		Childs	357
		Chinese	385
		Christmas Ornaments	599
		Circles, Brass	30, 31
		Circular Gothic No. 120	493
		Circular Italic No. 120	506
		Circular Quads	37
		Circular Script	470
		Clarendon Cond. No. 10	217
		Clarendon Cond. No. 120	217
		Clarendon Cond. No. 122	218
		Clarendon No. 120	216
		Classic Ornaments	599
		Cleveland Script	469
		Collins Bands	612
		Collins Borders	611
		Collins Florets	596, 597

- | | PAGE | | PAGE | | PAGE |
|---|---------------|---|---------------|--|------------------|
| Columbian | 364 | De Vinne Extra Cond. | 298, 299 | Foster Gothic Extended | 382 |
| Columbus Initials | 309 | De Vinne Fractions | 568 | Foster Gothic Extd. No. 2 | 382 |
| Columbus No. 2 | 308, 309, 433 | De Vinne Italic | 302, 303, 434 | Fraction Marks | 45 |
| Columbus Outline | 310, 311, 433 | De Vinne Italic Outline, 304, 395 | | FRACTIONS: | 44, 45, 568, 569 |
| Columbus Outline Initials, 311 | | De Vinne Shaded | 306, 434 | —Antique | 569 |
| Column Rules | 32 | Dewey Ornaments | 595 | —Caledonian | 569 |
| Combination Border, | | Diagonal Fraction Marks | 45 | —De Vinne | 568 |
| Series 98 | 640, 641 | Domestics | 649 | —De Vinne Cond. | 568 |
| Combination Cond. Gothic | 242 | Doric Fractions | 569 | —Doric | 569 |
| Combination Gothic | 242, 244 | Doric Italic | 284 | —Gothic | 569 |
| Combination Italic Gothic | 285 | Doric No. 120 | 223 | —Piece | 44, 45 |
| Combination Ornaments, | | Douglas | 360 | —Roman | 569 |
| Series K | 642 | Druggists | 650 | —Quentell | 568 |
| Commercial Logotypes | 576 | Duerer | 339 | —Self Spacing Piece | 44 |
| Commercial Signs | 46, 569 | Dynamo | 358 | —Special | 45 |
| Composite No. 150 | 549 | Earle Typewriter | 509 | French Antique No. 110 | 222 |
| Concave No. 120 | 225 | Eastman | 344, 345 | French Clarendon No. 120 | 220 |
| Concave Cond. No. 120 | 226 | Eccentric | 384 | French Clar. Extd. No. 120 | 221 |
| Concave Extd. No. 120 | 226 | Edinburgh Title | 157 | French Elzevir No. 1 | 140, 141 |
| Condensed Aldine No. 150 | 193 | Egyptian Extra Cond. | 219 | French Old Style Extd. | 169 |
| Condensed German Black | | Egyptian Extended No. 20 | 227 | French Old Style No. 1 | 159 |
| No. 150 | 545 | Egyptian Extended No. 30 | 227 | French Old Style No. 2, 135-139 | |
| Condensed No. 45 | 181 | Egyptian Ornaments | 594 | French Old Style No. 2 | |
| Condensed No. 124 | 181 | Eighteen Point Borders | 623 | Italic | 134, 480, 481 |
| Condensed Title No. 46 | 190 | Elandkay | 386 | French Script | 466, 467 |
| Condensed Title No. 104 | 191 | Elberon No. 2 | 356 | Full Face Italic No. 123 | 188 |
| Condensed Title No. 123 | 192 | Election Signs | 566 | Full Face No. 123 | 187 |
| Condensed Title No. 124 | 189 | Electrotyped Date Lines | 578 | Furniture, Metal | 36 |
| Cond. Title No. 125 | 190, 191 | Electrotyped Initials | 587-589 | Geometrical Borders | 637 |
| Contour No. 1 | 328 | Electrotyped Outline Fig-
ures | 723 | German Full Face | 544 |
| Contour No. 2 | 332 | Electrotyped Take Slugs | 37 | German No. 121 | 537-539 |
| Contour No. 3 | 332 | Elzevir Bands | 606 | German No. 153 | 540 |
| Contour No. 4 | 330 | Elzevir Borders | 606 | German No. 155 | 541 |
| Contour No. 5 | 333 | Elzevir Florets | 598 | German Title Cond. No. 150 | 542 |
| Contour No. 6 | 329 | Elzevir Gothic | 400, 401 | German Title No. 122 | 543 |
| Contour No. 7 | 331 | Empire Borders | 636 | Germania No. 150 | 549 |
| Contour Bands and Borders | | Empire Initials | 587 | GERMAN: | 536-549 |
| | 608, 609 | Empire Ornaments | 655 | —Composite No. 150 | 549 |
| Contour Palmetto Orn'm'ts | 591 | End-wood Borders | 795 | —Condensed German | |
| Contour Pointers | 590 | Engraving Blanks | 563 | Black No. 150 | 545 |
| Copper-Alloy Fine-Dot | | Epitaph | 322 | —German Full Face | 544 |
| Leaders | 50, 595 | Epitaph Open | 322 | —Germania No. 150 | 549 |
| Copper-Alloy Imprints | 244, 566 | Erebus | 323, 433 | —German Title Condens-
ed No. 150 | 542 |
| Copper-Alloy Take Slugs | 37 | Erratick | 318, 435 | —German Title No. 122 | 543 |
| Copperplate Roman | 389 | Erratick Outline | 319, 435 | —Heintzemann | 545 |
| Coppers | 650 | Euclid | 369 | —Ihlenburg | 548 |
| Corner Quads | 37 | Extra Cond. No. 123 | 194, 195 | —No. 121 | 537-539 |
| Crayon | 516 | Extra Condensed No. 234 | 194 | —No. 153 | 540 |
| Cursive Script | 479 | Facade | 372 | —No. 155 | 541 |
| Cushing | 142, 494 | Facade Condensed | 371 | —Schwabacher | 546 |
| Cushing Italic | 143, 495 | Facade Condensed No. 2 | 370 | —Schwabacher No. 2 | 547 |
| Cushing Monotone | 144, 145 | Fancy Grotesque | 492 | —Self Spacing | 536 ^a |
| Cushing Old Style | 172, 173 | Ferdinand | 346 | —Teutonic No. 150 | 544 |
| Cutting Rules | 27 | Fillet | 512 | Gothic Condens'd Fractions | 560 |
| Daisy Border | 633 | Fine-Dot Leaders | 50, 595 | Gothic Condensed No. 37 | 257 |
| Darling Border | 633 | Fists | 575 | Gothic Condensed No. 112 | 243 |
| Dashes | 34, 50 | Five-Pointed Stars | 567 | Gothic Condensed No. 122 | 255 |
| Dash Rules, Brass | 33 | Flag Borders | 639 | Gothic Condensed No. 123 | 254 |
| Date Lines | 578 | Flame Borders | 618 | Gothic Condensed No. 124 | 253 |
| Delmonico Chefs and Wait-
ers | 651 | Floral Border No. 1 | 631 | Gothic Condensed No. 127 | 248 |
| Devens Script | 472, 473 | Floral Border No. 2 | 631 | Gothic Condensed No. 128 | 249 |
| De Vinne | 294, 295 | Florentine Borders | 607 | Gothic Condensed No. 129 | 256 |
| De Vinne Condensed | 296, 297 | Florentine Heavyface | 343 | Gothic Ex. Cond. No. 122 | 252 |
| De Vinne Condensed Frac-
tions | 568 | Florentine O. S. No. 2 | 402, 403 | Gothic Ex. Cond. No. 150 | 251 |
| De Vinne Extended | 300, 301 | Foster Gothic | 383 | Gothic Fractions | 560 |

Gothic Italic No. 113	286
Gothic Italic No. 123	286
Gothic Italic No. 124	288
Gothic Italic Extra Cond.	289
Gothic No. 49	247
Gothic No. 122	261
Gothic No. 123	263
Gothic No. 124	264
Gothic No. 125	262
Gothic No. 127	245
Gothic No. 1510	247
Gothic Slope No. 20	288
Gothic Wide	278
Gothic Wide No. 2	279
Graphic	333
Graphic Text	448
Greek	554-558
Greek Letters (Job)	558
Grimaldi	503
Grolier	465
Grotesque No. 120	492
Gutenberg	503
Hades	323, 433
Half Nonpareil Borders	625
Half Title	183
Half-tone	517
Hamburg	447
Happood Florets	598
Happood Initials	587
Happy Thoughts	600
Hardware	215
Harvard Italic	482, 483
Head Rules, Brass	33
Heavyface Greek	558
Hebrew	550-552
Heintzemann	545
Hermes	368
Hoboes	651
Holly Border No. 1	631
Houghton	346
Howland	312, 313
Howland Open	312, 313
Thlenburg	548
Imprints	244, 566
Imprint Gothic	244
Inclined Antique	218
Inclined Gothic	287
Inclined Program	491
Index Corners	722
Index Initials	589
Index Cuts	575
Inferior Figures	45
Inferior Letters	45
INITIALS:	585-589
—Acorn	588
—Art	585
—Bradley	586
—Columbus	309
—Columbus Outline	311
—Empire	587
—Euclid	369
—Fifth	589
—Happood	587
—Index	589
—Ipsen	587
—Jenson	586

INITIALS—Continued

—Morris	589
—Mortised No. 2	585
—Renate	586
—Schœffer Old Style	586
—Series No. 50	586
—Series No. 51	586
—Series No. 52	586
—Series No. 320	587
—Series No. 321	587
—Series No. 421	588
—Series No. 425	588
—Series No. 426	588
—Series No. 440	585
—Series No. 441	585
—Series No. 1132	585
—Series No. 1133	585
—Series No. 1136	585
—Series No. 1143	585
—Series No. 1146	586
—Series No. 1147	586
—Series No. 1148	586
—Series No. 1155	585
—Series No. 1158	589
—Series No. 1159	589
—Sphinx	588
—Tendrill	586
—Trinal	381
—Waverley	588
—Wayside	587
Ink Spots	646
Inland No. 56	59, 98, 99
Inscription Greek	558
Insects	646
Interchangeable Gothic	246
Ionic No. 30	199
Ionic No. 120	200
Ionic No. 122	199, 200
Ionic No. 150	198
Ionic No. 159	199
Ipsen Initials	587
Iroquois	359, 351
Iroquois Condensed	352, 353
Isabella	499
Ivanhoe	396, 397
Jagged	386
Jefferson	335
Jenson	354
Jenson Embellishments	656-660
Jenson Initials	586
Jenson Italic	414-419
Jenson Old Style	408-413
Job Commercial Signs	569
Job Dashes, Brass	34
Johnson	362
Johnson Gothic	243
Kate Greenaways Mig- nonettes	652, 653
Kentucky	64, 107
Klondike Borders	638
Klondikers	646
Koster	356
Labor-Saving Brass Leaders	35
Labor-saving Brass Rule	28, 29

Labor-saving Leads and Slugs	37
Labor-saving Quotation Furniture	36
Laclede	450
Lady Speakers	649
Ladies' Hand Script	468
Lafayette	334
Latin Antique No. 120	234
Latin Compressed No. 30	233
Latin Condensed No. 150	232
Latin Extended	228
Laurel Borders	634
Laurel Ornaments	635
Laurel Wreaths	644
Law Italic No. 42	504
Law Italic No. 120	505
Law Italic No. 122	504
Leaders	35, 50, 505
Leads and Slugs	32, 37
Lightface Celtic Condensed No. 120	241
Lightface Celtic No. 150	238
Light-Face No. 158	184
Light Runic No. 110	235
Light Runic No. 152	235
Lincoln	361
Lining Antique	205
Lining Gothic No. 43	265
Lining Gothic No. 44	266
Lining Gothic No. 45	267
Lining Gothic Ex. No. 40	277
Lippincott	338
Listeners	648
Litho	496
Lithotint	517
Livermore	320, 433
Livermore Outline	321, 433
Locus Sigilli	565
Longfellow	359
Luray	514
Magnolia Script	469
Mail List Logotypes	42
Mail List Type	42
Maltese Crosses	567
Manila Border	595
Mansfield	355
Manuscript	471
Margin Ornaments	645
Master Script	475
McCullagh	290, 291
Medical Signs	46
Metal Braces	50
Metal Corner Quads	37
Metal Furniture	36
Mezzotint	513
Midget Tail Pieces	504
Mid Gothic	258, 259
Miscellaneous Signs	48, 49
Modern Antique	230, 231
Modern Antique Wide No. 110	229
Morning Glory	387
Morris Initials	580
Mortised	375
Multiform	434, 511
Mural	373

	PAGE
Mural Ornaments	645
Music	559-562
Myrtle Border	639
Newfangle	384
New Metal Braces	50
New Tuscan No. 120	225
Newspaper Borders 605, 619-623	
Newspaper Headings	580-584
Newspaper Sub-Headings	579
Nic-Nacs	590
Nonpareil Borders	626, 627
Nonpareil and One-Half Borders	628
Norman Condensed	240
Novelty Script	451
Octic No. 1	282
Octic No. 2	282
Ohio	63, 106
Old Style Antique No. 40	174
Old Style Antique No. 112	180
Old Style Antique No. 120	174, 175
Old Style Bold	168
Old Style Condensed No. 4	163
Old Style Condensed No. 40	157
Old Style Cond. No. 120	158
Old Style Cond. No. 122 160, 161	
Old Style Extended	165
Old Style Italic No. 83	155
Old Style Latin Condensed	233
Old Style No. 43	156
Old Style No. 83	113-117
Old Style No. 83, Card Ser.	154
Old Style Script	460
Old Style Title	176, 177
Old Style Two-Line	156
Open Title No. 120	189
ORNAMENTS:	
—Apple Blossom	593
—Central	591, 592
—Christmas	599
—Classic	599
—Collins Florets	506, 597
—Combination, Series K	642
—Contour Palmetto	591
—Dewey	595
—Egyptian	594
—Elzevir Bands	606
—Elzevir Florets	598
—Empire	655
—Hapgood Florets	508
—Happy Thoughts	600
—Insects	646
—Jenson Embellishments	656-660
—Laurel	635
—Margin	645
—Midget Tail Pieces	594
—Mural	645
—Palmetto	591
—Pin, Nail and Screw Heads	500
—Printers' Nic-Nacs	590
—Rule	593
—Schöffler	655
—Scroll Corner	593

ORNAMENTS—Continued	PAGE
—Shaded Palmetto	591
—Stellar	591
—Turner	591
—Typographic Charms	643
—Wayside	654
—Wayside Embellish- ments	655
Outing	387
OUTLINE TYPE:	
—Binner Open	327, 435
—Bradley Outline	432, 433
—Columbus Outline	310, 311
—Contour	328-331
—Contour Bands and Borders	608, 609
—Contour Pointers	590
—DeVenne Italic Out- line	304, 305
—De Vinne Shaded	306
—Epitaph Open	322
—Erratic Outline	319
—Figures	723
—Graphic	333
—Howland Open	312, 313
—Laurel Border	634
—Livermore Outline	321
—Quaint Open	315
—Satanick Open	420
—Virile Open	317
Ovals, Brass	31
Oxford No. 2	385
Palmetto Ornaments	591
Palo Alto	510
Parisian Black No. 120	445
Parthenian	166, 167
Pencilings	502
Pen Text	488
Perforating Rules	27
Perpetual Calendars	572, 573
Philadelphia Lining	
Gothic	268-276
Pica Borders	628, 629
Pickups	650
Piece Accents	51
Piece Fractions	44, 45
Piece Root Signs	48
Pin, Nail and Screw Heads	590
Pluto	376
Pointers	590
Pointer Borders	633
Polka-Dot Border	632
Porson Greek	554, 555
Poster Commercial	394, 395
POSTER FONTS:	
—Antique No. 125	526, 527
—De Vinne	522, 523
—De Vinne Cond.	524, 525
—Doric No. 120	532, 533
—Ionic No. 122	528, 529
—Latin Antique No.	120
120	530, 531
—Lightface No. 158	534, 535
—Lining Roman No.	153
153	110, 111
—O. S. Antique No. 120	521
—O. S. Antique No. 153	536
—Roman No. 123	112

	PAGE
Poster Roman Fractions	569
Printer's Nic-Nacs	590
Priory Text	438, 439
Program	491
Quaint	314
Quaint Gothic	377
Quaint Open	315
Quaint Roman, No. 2	337
Queen Anne Text	448
Quantell	292, 293
Quantell Fractions	568
Quincy Script	477
Quotation Furniture	36
Rabbinic	553
Ramona	502
Raphael	516
Recipe Marks	565
Red, White and Blue Border	602
Regal Borders	633
Regal Italic	388 ^a , 388 ^b
Rembrandt	519
Remington Standard	508
Renate Initials	589
Reversible Metal Furniture	36
Rigs and Traps	647
Rimpled	307
Ripple Text	448
Rivet	383
Rococo Border	605
Roman Extended No. 120	106
Roman Fractions	569
Roman, Modern	54-111
Roman No. 44	111
ROMAN AND ITALIC, MOD- ERN:	
American Press Association	
No. 61	62, 105
Century Roman	108, 109
Inland No. 56	59, 98, 99
Kentucky	64, 107
Ohio	63, 106
Romans, Newspaper	
Style	54-64
Romans, shown by	
sizes	65-84
Romans, shown by	
series	85-112
Scripps No. 58	61, 102-104
Self Spacing	54, 85-87
Series No. 45	55, 88, 89
Series No. 46	56, 90, 91
Series No. 47	92-94
Series No. 49	57, 95
Series No. 50	58, 96, 97
Series No. 57	60, 100, 101
ROMAN AND ITALIC, OLD	
STYLE:	
Barth	120-121
Caslon No. 71	127-131
Caslon Italic No. 71	132, 133
Caxton	150-153
Cushing	142
Cushing Italic	143
Cushing Monotone	144, 145
French Elzevir No. 1	140, 141
French O. S. No. 2	135-139

ROMAN AND ITALIC OLD	
STYLE—Continued	
French O. S. No. 2 Italic	134
Ronaldson	122-126
Self Spacing	146-148
Series No. 82	118, 119
Series No. 83	113-117
Romanesque	240
Ronaldson	122-126
Ronaldson Clarendon	179
Ronaldson Condensed	162
Ronaldson Extended	164
Ronaldson Gothic	280
Ronaldson Title Slope	176
Roumanian	520
Round Gothic	283
Royal Gothic	260
Royal Script	452, 453
Rubens	340, 341
Rule Ornaments	593
Runic Condensed No. 120	236
Runic Condensed No. 122	237
Russian No. 10	553
Rustic Band Border	632
Samoa	347
Sansom Script	464
Santa Cruz	510
Satanick	421-423, 435
Satanick Open	420, 435
Schœffer Old Style	404-407
Schœffer Old Style Initials	406, 407, 586
Schœffer Ornaments	655
Schwabacher	546
Schwabacher No. 2	547
Scorchers	647
Scoring Rules	27
Scripps No. 58	61, 102-104
Script No. 9	474
SCRIPT TYPE:	
—American	456, 457
—Autograph	477
—Boston	454, 455
—Carpenter	469
—Chicago	490
—Circular	470
—Cleveland	469
—Cursive	479
—Devens	472, 473
—French	466-467
—Laclede	450
—Ladies' Hand	468
—Magnolia	469
—Manuscript	471
—Master	475
—No. 9	474
—Novelty	451
—Old Style	460
—Quincy	477
—Royal	452, 453
—Sansom	464
—Shepard	476
—Spencerian	461-463
—Spinner	490

SCRIPT TYPE:—Continued	
—Steelplate	458, 459
—Title	449
—Vertical Writing	478
Scroll Corner Ornaments	593
Sectional Calendars	574
Self Spacing German	536 ^a
Self Spacing Modern Roman	52-54, 85-87
Self Spacing Piece Fractions	44
Self Spacing Old Style Bold	149
Self Spacing Old Style Roman	146, 147
Self Spacing O. S. Italic	148
Self Spacing Signs	53
Shaded Palmetto Ornaments	591
Shaded Pointers	590
Shadow	514
Shaved Leads and Slugs	37
Shepard Script	476
Shoppers	649
Signet	501
Signet Shade	518
Signs	46-49, 53, 569
Silhouettes	650
Six Point Braces and Dashes No. 2	50
Six Point Metal Braces	50
Six Point Stars	567
Skjald	390, 391
Stocum Seals	646
Slugs	32, 37
Smith-Premier Typewriter	509
Space Rule	27
Speakers	648
Special Figures	49
Special Fractions	45
Special Logotypes	49
Spencerian Script	461-463
Spinner Script	490
Standard Lining Antique	374
Star Rule	794
Stars	567, 742
Steel Cutting Rules	27
Steelplate Gothic	515
Steelplate Script	458, 459
Stellar Ornaments	591
Stencil	519
Stipple	512
Stylus	487
Stylus No. 2	486
Superior Figures	45
Superior Letters	45
Synopsis of Roman Body Type	39-41
Take Slugs	37
Taylor Gothic	342
Telescopic Gothic	244
Tendril Initials	586
Teutonic No. 150	544
Three-line Nonpareil Borders	630

PAGE	
Three-line Pica Borders	630
Time-saving Mail List Type	42
Time-table Figures	43
Tinted	515
Title Black	444
Title Expanded No. 120	197
Title Script	449
Touraine O. S. Italic	484, 485
Trinal	381
Tristan Italic	489
Tudor Black	442, 443
Turner Ornaments	591
Twelve Point Borders	624
Twenty-four Point Borders	624
Two-color Borders	601-604
Two-color Type Styles	433-435
Two-line Pica Borders	630
Two-line Letter No. 35	182
Two-line Letter No. 124	182
Two-line Letter No. 128	183
Two-line Letter No. 129	182
Two-line No. 151	183
TYPEWRITER:	
—Caligraph	508, 509
—Earle	509
—No. 2	509
—Remington Standard	508
—Smith-Premier	509
—Yost	508
—12 Point	509
Type	355
Typographic Charms	643
Union Border	603
Unique Celtic	366
Unique Celtic Condensed	367
United States Signal Flags	563
University	185
Venetian	507
Venus	519
Vertical Writing	478
Victoria	379
Victoria Italic	388
Virile	316, 435
Virile Open	317, 435
Walton	358
Washington	336
Waverly Circular	496
Waverley Initials	588
Wayside Embellishments	655
Wayside Initials	587
Wayside Ornaments	654
Weather Indicators	563
Webster	365
Whist Markers	565
Whiteface Figures	43
Wood Borders	795
Wood Pointers	794
Wood Rule	794
Wood Type	793-816
Yonkers	446
Yost Typewriter	508

INDEX AND PRICE LIST OF CUTS

	PAGE		PAGE		PAGE
Animals	726-733	Menu Cuts	738, 739	Society Emblems— <i>Continued</i>	
Beehives	713	Newspaper	689	Miscellaneous	705-717
Bells	719	Outline Figures	723	National, Foreign	714, 715
Bicycles	725	Political Roosters	734, 735	Odd Fellows	705
Billhead Logotypes	576	Portraits	697	O. U. A. M.	709
Bill-of-Fare	738, 739	Poultry	734, 735	P. O. S. of A.	712
Blank Books	741	Railroad	736	Railroad Men	713
Buffalo	731	Religious	709, 701	Red Men	707
Business Cuts	723-743	Society Emblems	695, 698-717	Royal Arcanum	709
Cattle	732, 733	American, Patriotic	716, 717	Salvation Army	710
Check Blanks	577	A. O. U. W.	708	Sons of Veterans	695
Coats-of-Arms	690, 691, 696	Catholic Societies	714	Temperance	710
Crowns	721	Christian Endeavor	698, 699	Sports	725, 730
Dentist	724	Epworth League	698, 699	Stars	567, 742
Druggist	724	Firemen	713	State Seals	690, 691
Eagles	692, 693	Foresters	708	Steamships	737
Eye and Eye Glasses	724	Good Templars	710	Tail Pieces	744
*Flags	694, 696	Grand Army	695	Trolley Cars	729
Horses	726-729, 733	Knights of Pythias	706	Typographical	718, 741
Index Corners	722	K. of G. E.	707	U. S. Emblems	692-694
Locomotives	736	L. A. W.	709	Vehicles	728, 729
Masquerade	725	Masonic	702-704	Wine List	738, 739

* Old Glory Embossing Sets (page 694)—Set A, \$3.00; Set B, \$4.50; Set C, \$6.00

NO.	PAGE	PRICE	NO.	PAGE	PRICE	NO.	PAGE	PRICE	NO.	PAGE	PRICE
234A	714	\$.40	3092A	707	\$.50	3163A	715	\$1.25	4389A	717	\$.75
828A	713	1.00	3104A	705	.40	3166A	710	.75	4392A	717	.60
987A	714	.60	3109A	702	.35	3167A	711	1.00	4393A	716	.60
1750A	734	.50	3110A	705	.40	3169A	708	1.00	4394A	717	.60
1752A	734	1.00	3111A	705	.60	3170A	715	.60	4395A	716	.60
1850A	702	.40	3118A	705	.75	3171A	708	1.00	4396A	717	.60
2014A	713	.40	3119A	705	.75	3172A	714	.50	4397A	717	.75
2069A	714	.30	3121A	705	1.00	3173A	714	.75	4398A	717	.65
2079A	702	.50	3122A	705	1.00	3174A	714	.60			
2105A	713	.50	3123A	705	1.00	3175A	714	.40	77B	703	.15
2241A	703	.75	3126A	706	.60	3176A	711	.50	79B	703	.15
2287A	705	.50	3129A	707	.60	3177A	714	1.25	80B	703	.15
2319½A	710	.75	3131A	717	.35	3178A	714	.75	81B	703	.15
2434A	703	1.00	3132A	709	.50	3181A	709	.75	82B	703	.15
2438A	703	1.00	3133A	709	.60	3184A	709	.30	83B	703	.15
2754A	704	.50	3135A	707	.40	3185A	709	1.00	96B	724	.25
2766A	705	.90	3136A	707	.60	3186A	708	1.00	132B	721	.30
2820A	707	.50	3138A	711	.50	3189A	715	.50	161B	697	1.50
2857A	711	1.00	3139A	709	.60	3190A	709	1.25	163B	703	.75
2882A	721	.30	3141A	711	.50	3191A	708	.75	Three colors, 1.50		
3024A	703	.30	3142A	710	.50	3194A	715	1.25	164B	703	.50
3027A	702	.30	3143A	715	.60	3196A	711	1.25	Three colors, 1.25		
3033A	704	.75	3144A	715	.60	3198A	713	1.00	166B	702	.30
3044A	702	.75	3145A	715	.30	3200A	713	1.00	168B	702	.75
3050A	704	.75	3146A	709	.60	3201A	713	.75	170B	702	.40
3055A	704	1.25	3147A	710	.50	3321A	703	1.00	172B	702	.25
3059A	702	.75	3148A	710	.50	3323A	702	.60	173B	705	.25
3060A	703	1.00	3149A	710	.75	3325A	704	.75	174B	705	1.00
3061A	704	.50	3150A	710	.60	3327A	702	.75	Two colors, 1.50		
3064A	704	.75	3152A	707	1.00	4041A	708	.55	175B	705	1.00
3066A	702	.75	3153A	707	1.00	4361A	716	.60	176B	705	1.00
3072A	703	1.00	3154A	710	1.00	4362A	716	.60	Two colors, 1.50		
3077A	702	.40	3155A	711	1.00	4363A	716	.60	177B	705	.35
3078A	702	.75	3157A	707	.60	4364A	716	.60	179B	705	.25
3079A	702	1.00	3159A	712	.50	4365A	717	.65	180B	705	.30
3081A	704	.75	3159½A	710	.50	4366A	716	.60	181B	705	.60
3083A	702	1.00	3160A	715	.40	4368A	716	.60	183B	707	.40
3089A	707	.75	3161A	712	.75	4388A	716	.75	184B	707	.90

NO.	PAGE	PRICE	NO.	PAGE	PRICE	NO.	PAGE	PRICE	NO.	PAGE	PRICE			
185B	.706	\$1.00	257B	.708	\$.60	2466C	.724	\$.50	2971C	.700	\$.25			
186B	.706	.75	258B	.715	.90	2470C	.728	.75	2974C	.721	.50			
187B	.706	1.00	259B	.711	1.00	2471C	.692	.50	2994C	.739	.30			
188B	.706	.75	260B	.711	.75	2477C	.721	1.50	2998C	.700	.25			
Three colors, 2.00														
190B	.708	1.25	261B	.711	.40	2530C	.693	.30	3002½C	.700	1.15			
191B	.708	.50	262B	.715	.75	2546C	.666	1.00	3023C	.693	.30			
192B	.707	.75	263B	.715	.75	2554C	.666	.60	3024C	.739	.75			
Four colors, 2.00														
193B	.695	.45	264B	.713	.40	2559C	.696	1.25	3030C	.700	.30			
196B	.695	.60	265B	.730	1.25	2563C	.696	1.80	3031C	.700	.30			
197B	.695	.60	266B	.713	.50	2567C	.696	2.50	3034C	.718	1.00			
198B	.695	.60	267B	.707	.75	2678C	.724	.75	3037C	.726	.60			
199B	.717	1.00	268B	.711	1.15	2681C	.724	1.25	3038C	.726	.60			
200B	.695	.90	269B	.740	1.00	2687C	.725	.25	3051C	.720	.75			
201B	.695	.75	270B	.740	1.00	2695C	.726	.75	3054C	.734	1.50			
202B	.695	.75	271B	.740	.50	2700C	.741	1.50	3055C	.730	.40			
203B	.714	1.00	272B	.740	.35	2703C	.742	1.00	3060C	.733	.50			
204B	.714	.90	273B	.740	.45	2704C	.742	.75	3062C	.733	.30			
205B	.714	.75	275B	.740	.50	2708C	.697	1.50	3094C	.732	.75			
206B	.715	.60	276B	.724	.50	2712C	.694	.75	3095C	.740	.50			
207B	.715	.90	278B	.699	.40	Two colors, 1.25						3118C	.691	1.00
208B	.715	.40	3559B	.735	.50	2713C	.694	.75	3119C	.691	1.00			
209B	.714	.50	3846B	.575	.30	Two colors, 1.25						3120C	.691	1.00
210B	.714	.75	3847B	.575	.30	2727C	.693	.25	3121C	.691	1.00			
211B	.715	.75	3852B	.575	.25	2749C	.740	.45	3122C	.691	1.00			
212B	.715	.90	3853B	.575	.25	2751C	.690	1.75	3123C	.691	1.00			
213B	.698	.75	with Seal, 2.50						3124C	.691	1.00			
214B	.698	.60	170C	.724	.40	2752C	.692	.75	3126C	.691	1.00			
215B	.698	.75	236C	.700	.08	2771C	.690	.75	3127C	.691	1.00			
216B	.698	.90	420C	.700	.30	2773C	.690	.75	3128C	.691	1.00			
217B	.698	.35	1225C	.700	.25	2775C	.690	.75	3132C	.691	1.00			
220B	.698	.35	1733C	.727	.50	2776C	.690	.75	3137C	.691	1.00			
221B	.699	.40	1856C	.727	.50	2778C	.690	.75	3142C	.719	1.25			
222B	.699	.40	1857C	.728	.50	2779C	.690	.75	3143C	.718	1.00			
223B	.698	.50	1863C	.696	.40	2780C	.690	.75	3146C	.720	.75			
224B	.699	.60	2016C	.719	.25	2807C	.737	1.00	3153C	.718	.80			
225B	.699	.60	2042C	.739	.50	2817C	.728	.40	3160C	.742	2.75			
226B	.698	.75	2048C	.710	.75	2819C	.742	1.00	3165C	.701	.40			
227B	.698	.50	2070C	.728	2.00	2825C	.742	1.25	3166C	.700	.40			
228B	.699	.75	2092C	.726	.50	2830C	.742	1.50	3167C	.701	.40			
229B	.698	.50	2134C	.739	.25	2835C	.742	5.00	3168C	.700	.40			
230B	.698	.50	2135C	.700	.25	2850C	.742	4.00	3169C	.700	.80			
231B	.699	1.00	2165C	.732	1.50	2854C	.729	.50	3170C	.700	.40			
232B	.699	.60	2171C	.729	.50	2857C	.742	3.00	3171C	.700	.30			
233B	.698	.50	2197C	.720	1.00	2872C	.692	2.50	3172C	.700	.30			
234B	.699	.75	2213C	.692	2.50	2873C	.692	5.00	3175C	.720	.80			
235B	.699	.40	2213½C	.692	1.50	2874C	.692	6.25	3182C	.693	.75			
236B	.699	.40	2235C	.690	1.50	2875C	.692	15.00	3183C	.693	1.50			
237B	.699	.70	2258C	.693	1.50	2891C	.740	.50	3189C	.739	.50			
238B	.699	.75	2285C	.739	.37	2898C	.729	1.25	3190C	.739	.60			
239B	.698	.90	2309½C	.700	.38	2901C	.743	1.00	3201C	.739	1.25			
240B	.699	.40	2312½C	.727	.38	2902C	.729	.50	3204C	.726	.60			
241B	.699	.40	2317C	.720	.40	2904C	.697	.50	3207C	.742	8.00			
242B	.699	.40	2332C	.732	1.00	2906C	.725	.75	3271C	.718	.60			
243B	.699	.40	2356C	.729	.50	2926C	.720	1.50	3272C	.718	.75			
244B	.699	.75	2385C	.692	.75	2929C	.735	1.00	3273C	.718	1.00			
245B	.699	.35	2395C	.720	.30	2937C	.720	.50	3276C	.736	.60			
246B	.709	.40	2408C	.719	1.00	2941C	.719	.25	3279C	.700	.50			
247B	.709	.50	2418C	.737	.50	2942C	.719	.15	3280C	.718	.40			
248B	.709	.75	2419C	.713	.40	2943C	.713	.15	3281C	.718	.60			
249B	.713	.90	2425C	.724	.40	2945C	.730	.25	3288C	.726	.75			
250B	.713	.50	2431C	.703	1.00	2948C	.719	.25	3289C	.720	.30			
251B	.713	.50	2432C	.702	.50	2950C	.719	.25	3290C	.718	.50			
252B	.713	.50	2435C	.697	1.50	2951C	.720	.15	3293C	.713	.30			
253B	.713	.50	2439C	.713	1.00	2968C	.693	.50	3298C	.739	.50			
254B	.708	1.00	2441C	.719	1.00	2969C	.694	.30	3354C	.701	.35			
255B	.712	1.50	2442C	.692	.30	Per dozen, 2.50						3355C	.701	.35
256B	.710	.75	2443C	.693	.30	Two colors, .50						3356C	.701	.40
			2458C	.729	.25	Per dozen, 4.50						3357C	.701	.35
			2465C	.732	.50	2970C	.703	.50	3358C	.701	.25			

NO.	PAGE	PRICE	NO.	PAGE	PRICE	NO.	PAGE	PRICE	NO.	PAGE	PRICE
3359C	700	\$.25	3661C	709	\$.30	3996C	708	\$.75	4185C	714	\$.75
3360C	701	2.00	3662C	706	.40	3997C	736	.75	4186C	725	.75
3361C	700	.50	3669C	742	.75	3998C	666	.75	4188C	725	.75
3362C	700	.30	3674C	730	1.25	3999C	666	1.00	4201C	723	.50
3363C	701	.30	3677C	730	1.25	4000C	666	1.50	4205C	723	.50
3364C	701	.30	3679C	742	1.50	4037C	722	.35	4209C	723	.50
3365C	701	.35	3682C	703	.50	4038C	722	.35	4211C	723	.50
3369C	725	1.25	3683C	706	.50	4039C	722	.35	5089C	741	.50
3370C	726	.50	3685C	710	.50	4040C	722	.35	Four colors, 2.00		
3372C	700	.35	3700C	690	1.50	4041C	722	.35	5091C	731	1.00
3378C	726	.50	3709C	744	.25	4042C	722	.35	5096C	731	.75
3380C	728	1.00	3711C	714	.35	4043C	722	.35	5097C	731	1.00
3383C	701	.35	3712C	739	.40	4044C	722	.35	5098C	731	.50
3384C	701	2.00	3756C	732	1.25	4045C	722	.50	5099C	731	.75
3386C	733	1.50	3778C	697	1.50	4046C	722	.50	5100C	731	.50
3388C	725	1.25	3779C	697	1.00	4047C	722	.50	5107C	666	1.50
3393C	704	1.00	3780C	692	1.50	4048C	722	.50	5108C	666	1.25
3394C	704	1.00	3781C	693	1.25	4049C	722	.50	5109C	666	.90
3395C	704	1.00	3785C	725	.75	4050C	722	.50	5111C	666	.75
3396C	704	1.00	3786C	730	.40	4051C	722	.50	5112C	666	1.25
3397C	704	1.00	3787C	731	1.25	4052C	722	.50	5114C	666	1.00
3398C	704	1.00	3788C	742	1.00	4053C	722	.50	5123C	666	.50
3399C	702	.50	3790C	706	1.00	4054C	738	.75	5127C	694	3.50
3400C	702	.50	3791C	736	1.25	4056C	738	.75	5127½C	694	2.25
3401C	702	.50	3792C	739	1.25	4058C	738	.75	5142C	694	1.25
3402C	702	.50	3794C	719	.50	4059C	738	.75	5143C	694	2.00
3403C	702	.50	3795C	719	.75	4060C	738	.60	5144C	694	1.50
3404C	702	.50	3796C	719	1.25	4065C	738	.75	5145C	694	2.50
3407C	700	.60	3800C	734	.30	4066C	738	.75	5151C	666	.90
3409C	720	1.00	3816C	735	1.50	4069C	738	.75	Two colors, 1.40		
3410C	724	1.00	3818C	697	1.50	4070C	738	.60	5152C	666	.90
3417C	706	.30	3852C	744	.60	4071C	738	.75	Two colors, 1.40		
3418C	706	.60	3866C	744	.60	4092C	729	.75	5153C	666	1.00
3419C	706	.75	3867C	744	.60	4093C	729	1.25	Two colors, 1.60		
3426C	721	1.00	3872C	744	.75	4095C	697	.40	5154C	666	1.00
3432C	742	.40	3878C	744	1.25	4096C	719	1.25	Two colors, 1.60		
3434C	727	1.50	3881C	744	1.25	4099C	735	1.00	5155C	666	1.25
3436C	726	.60	3883C	744	.50	4100C	741	.75	Two colors, 2.00		
3438C	719	.40	3886C	744	.40	4101C	741	.75	5156C	666	1.25
3440C	742	.75	3887C	744	.40	4103C	739	.75	Two colors, 2.00		
3445C	720	.60	3902C	744	1.00	4104C	739	.75	5160C	731	1.25
3450C	727	2.00	3904C	744	1.00	4105C	740	.75	5162C	731	1.25
3451C	725	.50	3929C	692	1.85	4106C	740	.75	5163C	731	1.00
3453C	693	1.25	3938C	697	1.25	4118C	740	.75	5164C	731	.75
3454C	703	1.00	3941C	737	1.00	4119C	724	.75	12,134C	666	.35
3455C	700	.50	3944C	720	.25	4120C	713	.75	12,137C	666	.40
3456C	728	1.00	Per dozen, 2.00			4121C	709	.40	12,167C	715	.30
3460C	693	.25	3948C	720	.75	4122C	709	.40	12,173C	725	.40
3462C	724	1.00	3949C	720	.50	4123C	709	.75	12,176C	724	.60
3466C	737	.50	3952C	695	1.00	4124C	709	1.00	12,177C	724	.40
3476C	719	.75	3953C	695	.75	4125C	695	.40	12,178C	724	.50
3484C	742	1.00	Four colors, 2.50			4127C	730	.75	12,180C	720	.50
3490C	710	1.75	3954C	721	.75	4129C	742	.30			
3501C	744	1.25	3955C	695	.60	4130C	742	.35	1294D	741	.80
3503C	744	1.25	3957C	725	.60	4131C	742	.40	1386D	730	.50
3512C	744	.60	3958C	723	.90	Mortised, .70			1406D	575	.60
3535C	744	.50	3968C	723	.90	4140C	702	1.00	1407D	575	.60
3536C	744	.50	3970C	703	.60	4141C	697	.75	1521D	575	.50
3540C	740	.50	3972C	707	.60	4144C	709	.60	1522D	575	.50
3558C	740	.50	3982C	721	.30	4148C	697	.40	1602D	733	.35
3559C	740	.50	3986C	722	.25	4149C	697	.35	1603D	733	.35
3620C	700	1.00	3987C	722	.25	4152C	698	.40	1604D	733	.35
3638C	740	2.00	3988C	722	.25	4153C	698	.30	1605D	733	.35
3653C	700	.35	3989C	722	.25	4167C	729	.40	1606D	733	.35
3654C	703	.40	3990C	722	.25	4168C	729	.60	1607D	733	.35
3655C	700	.30	3991C	722	.25	4178C	743	.35	1608D	733	.35
3657C	707	.40	3992C	722	.25	Per set, 2.00			1609D	733	.35
3658C	707	.35	3993C	722	.25	Per set, 1.00			1610D	733	.35
3659C	710	.40	3995C	730	.60	4179C	743	.35	1611D	733	.35

NO.	PAGE	PRICE	NO.	PAGE	PRICE	NO.	PAGE	PRICE	NO.	PAGE	PRICE
1612D	733	\$.35	613E	689	\$.15	2029E	717	\$1.00	1329F	706	\$.50
1613D	733	.35	615E	689	.20	2032E	742	.40	1331F	708	.50
1629D	727	.75	616E	732	.15	2033E	721	1.25	1336F	708	.50
1744D	721	.35	617E	689	.25	2034E	721	.75	1343F	717	.75
1795D	727	.35	620E	689	.20	2036E	721	.50	1344F	712	.75
1824D	721	.75	652E	739	.20	2037E	721	.50	1361F	707	.50
1870D	718	.25	657E	689	.15	2038E	721	.25	1381F	711	.40
1871D	718	.35	667E	689	.25	2039E	721	.35	1789F	689	.15
1872D	718	.50	672E	730	.25	2040E	721	.25	2527F	689	.15
1873D	718	.60	700E	724	.30	2042E	721	.45	2537F	689	.25
1874D	718	.75	701E	724	.20	2044E	721	.75	2544F	689	.15
1875D	718	1.00	707E	689	.20	2045E	724	.50	2600F	689	.20
1876D	718	1.50	709E	732	.25	2046E	735	1.00	2657F	732	.20
1877D	718	2.00	711E	732	.25	2047E	735	1.00	2658F	726	.25
2253D	741	.80	712E	689	.30	2048E	734	2.00	2660F	732	.25
2694D	737	.75	717E	729	.25	2049E	733	1.00	2662F	730	.25
3932D	741	.90	726E	689	.15	2050E	732	1.00	2801F	689	.08
10,332D	725	.80	727E	689	.15	2051E	732	.75	2802F	689	.25
			728E	689	.15	2052E	726	1.00	4001F	575	.05
1E	689	.08	729E	689	.15	2053E	733	1.00	4002F	575	.05
24E	689	.12	731E	732	.25	2054E	726	1.00	4003F	575	.05
117E	689	.12	732E	727	.25	2055E	726	1.00	4004F	575	.05
123E	689	.15	733E	689	.15	2056E	727	.30	4005F	575	.05
124E	689	.15	734E	689	.15	2057E	727	1.00	4006F	575	.05
125E	689	.15	735E	689	.15	2058E	736	.90	4007F	575	.10
315E	689	.15	736E	689	.15	2059E	736	1.75	4008F	575	.10
319E	689	.25	737E	689	.15	2061E	736	1.00	4009F	575	.10
322E	729	.15	743E	725	.25	2062E	736	1.00	4010F	575	.10
352E	689	.10	744E	725	.25	2063E	728	.50	4011F	575	.10
364E	689	.15	748E	689	.20	2064E	728	1.00	4012F	575	.10
370E	689	.20	803E	693	.30	2066E	728	1.00	4013F	575	.15
409E	689	.08	804E	726	.25	2067E	710	.75	4014F	575	.15
412E	689	.10	807E	689	.25	2068E	737	1.00	4015F	575	.20
416E	689	.10	850E	730	.30	2069E	737	.75	4016F	575	.20
419E	689	.15	852E	689	.25	2071E	737	1.00	4017F	575	.25
422E	689	.10	857E	692	.30	2072E	737	1.00	4018F	575	.25
423E	689	.12	859E	735	.30	2074E	730	.60	4020F	725	.20
428E	702	.20	862E	689	.25	2075E	730	1.00	4021F	689	.25
431E	689	.12	865E	724	.30	2076E	731	.50	4029F	689	.30
432E	689	.25	868E	724	.35	2077E	700	.75	4030F	689	.20
433E	689	.12	902E	711	.30	2078E	701	1.25	4031F	689	.20
435E	689	.15	903E	709	.30	2079E	701	.75	4042F	734	.20
436E	724	.20	911E	689	.25	2080E	700	.35			
437E	689	.15	916E	704	.30	2081E	701	.70			
440E	689	.10	917E	732	.30	2090E	730	.40			
444E	689	.10	1052E	575	.08						
446E	689	.15	1053E	575	.08	1109F	695	1.00			
448E	689	.15	1070E	575	.15	1116F	705	.40			
450E	689	.20	1071E	575	.15	1204F	709	1.00			
451E	689	.20	1072E	575	.12	1207F	709	.50			
455E	724	.20	1073E	575	.12	1208F	712	.60			
456E	689	.15	1074E	575	.20	1211F	706	.50			
464E	728	.20	1075E	575	.20	1224F	704	.75			
465E	728	.15	1078E	575	.30	1230F	703	.75			
466E	729	.15	1079E	575	.30	1232F	706	.60			
468E	725	.20	1274E	710	.40	1238F	708	1.25			
500E	689	.15	1341E	712	.50	1258F	712	.60			
501E	689	.12	2007E	711	1.00	1262F	707	.50			
502E	689	.12	2011E	711	1.00	1264F	707	.75			
506E	689	.12	2013E	704	1.00	1266F	707	1.00			
511E	689	.15	2015E	705	.75	1268F	712	.90			
514E	692	.25	2016E	706	.60	1273F	715	.50			
517E	689	.20	2018E	708	1.00	1275F	706	1.00			
526E	689	.20	2022E	695	1.00	1277F	712	.50			
527E	724	.25	2023E	710	.75	1285F	715	.60			
532E	689	.25	2024E	711	.50	1301F	711	.40			
604E	689	.15	2025E	712	.50	1324F	712	1.00			
608E	689	.20	2026E	712	.75	1328F	710	.60			
612E	689	.30	2028E	712	.75						

4057F	729	.20
4059F	689	.15
4060F	689	.20
4062F	689	.20
4063F	689	.15
4064F	689	.20
4065F	732	.20
4099F	734	.30
Per dozen, 2.50		
4100F	694	.25
4108F	689	.15
4110F	711	.25
4115F	724	.30
4122F	725	.30
4123F	725	.35
4124F	725	.30
4125F	725	.30
4126F	725	.30
4128F	689	.30
4129F	729	.30
4149F	735	.30
Per dozen, 2.50		
7048H	712	.75
7049H	712	1.50

INDEX TO USEFUL INFORMATION FOR PRINTERS

	PAGE		PAGE
Accents Used in Foreign Languages	51	Metric System of Weights and Measures	987
American Point System	14	Number of Ems in One Pound of Type	14, 982
Capacity of each box in type case—useful in ordering sorts	46	Number of Ems in Square Inches of Type	982
Definitions of Signs	14	Number of Leads to the Pound	982
Directions for Securing Copyrights	984-986	Number of Words in a Square Inch	983
How to Estimate	14	Price List of Printing and Binding	997-1024
How to Order Sorts	14	Proofreaders' Marks	984
Imposition of Forms	988-996	Proportion of Type Bodies	981
—Diagrams of Imposition	990-996	Roman Numerals	982
—Gripper Margins	989	Sizes of Newspapers	32
—Imposition of Cuts and Tables	989	Table for Newspaper Estimates	981
—Margins	988	Table Showing Amount of Paper Required	984
—Press Points, uses of	989	Table Showing Number of Staples to One Pound of Wire	952
—Testing Margins	989	To Print Consecutive Numbers	983
—Tests of Impositions	980	Type Standards	14

INDEX TO MACHINERY AND MATERIALS

For the Composing Room	817 to 873	For the Stock Room and Bindery	928 to 971
For the Press Room	874 to 927	For the Mailing Department	972 to 974
Miscellaneous	975 to 979

	PAGE		PAGE
Acme Staple Binders	944-946	Books for Printers	975
Adamson Disc Cover	890	Boxwood	975
Addressing Machines	972-974	Brackets	866
Air Tools (Engraving)	977	Brass Bound Press Boards	969
Automatic Knife Grinders	939	Brass Galleys	826, 827
Backing for Electrotypes	978	Brass Label Holder	820
Beating Tables	837	Brass Rule Curving Machines	825
Bellows	822	Brass Type	16, 959
Belting	875	Brayers	892
Bentrovato	891	Bronze Powders	888
Benzine Cans	878	Bronzing Machines	927
—Success Safety	878	Bronzing Mitten	893
—Union Safe	878	Bronzing Pad	893
—Union Storage	878	Brushes, Benzine	875
Blankets, Felt and Rubber	874	—Cement	875
Bodkins	817	—Lye	875
Bone Folders	876	—Padding Glue	875
Bookbinders' Cabinet	959	—Proof	875
Bookbinders' Case	862, 959	—Stereotype Beating	875
Bookbinders' Gold Leaf Stamping Presses	960	Burbank's Embossing Composition	891
Bookbinders' Job Backer	955	Cabinets	853-865
Bookbinders' Lettering Pallet	959	—American-Polhemus	856, 857
Bookbinders' Press Boards	969	—American Steel-Run	854
Bookbinders' Stamping Presses	960, 961	—Blank Case	861
Bookbinders' Standing Presses	968	—Bookbinders'	862, 959
Bookbinders' Table Shears	941	—Border and Script Type	863
Bookbinders' Type	16, 959	—Combination No. 1	859
Bookbinders' Wire	951, 952	—Eagle	859
Book Sewing Machine, Tennis	953	—Electro and Cut	861

Cabinets—Continued	PAGE		
—Handy Sort	864	Counters—Continued	PAGE
—Galley	831	—Double Dial Alarm	885
—Handy Letter Board	843	—Durant	885
—Indexed Electrotpe	860	Countershafts	923
—Ink and Roller	890	Crown Engraving Plates	977
—Linotype Matrix	865	Curving Machines	825
—Paper and Card Stock	864	Cutting and Creasing Press, Gally Universal	905
—Porter's Extension Front, Steel-Run	855	Cutting Boards	969
—Rowen Border and Script	863	Cutting Sticks and Strips	938
—Sort	864	Dillingham Press Punch	879
—Specimen	865	Disc Cover, Adamson	890
—Steel-Run American-Polhemus	857	Dividers	822, 876
—Wisconsin Hard Wood	853	Dryers	888
—Wisconsin Window	858	Drying Racks	894, 895
—Wood Type	862	—Chicago	894
Card Cutters	940, 941	—Kärner's Interlocking	895
Cases	844-849	—Movable	894
—Combination Quarter	846	—New York	894
—Compact Rule	847	Electricity Dissipater	891
—Full-size	844	Elite Rule Bender	824
—Harris Rule	847	Embossing Composition	891
—Individual Lead or Rule	846	Embossing Made Easy	891
—Job	848, 849	Embossing Presses	904, 960, 961
—Mammoth Wood Type	849	—Carver & Swift	961
—Metal Furniture	849	—Gally Universal	904
—Patent Clasp	844, 845	—Hand	960
—Rooker	845, 848	—Monitor Lever No. 2	961
—Rule	845, 847	Emmerich Bronzing Machine	927
—Script or Wood Type	849	Engravers' Tools	975
—Space and Quad	849	Engravers' Wood	975
—Special	845	Engraving Plates, Hoke Crown	977
—Three-quarter	844	Eureka Type Wash	890
—Two-third	845	Eyeletting Machines	956-958
Case Racks	851, 862	—No. 4	958
Case Stands, Wood	850, 851	—Petit Foot-power	956
Case Stands, Wrought Iron	852	—Royal	957
Chases	834-837	—Self-feed Foot-power	957
—Book or Shifting Bar	834	—Victor	957
—Cast Iron	835	Eyelet Punch and Set	958
—Electrotype	835	Eyelts	956
—For Job Presses	836	Eye Shade	817
—Heading, with Cross-bar	834	Folding Machines	924-926
—Newspaper, Folio	835	—Bennett Country Quarto	926
—Newspaper, Quarto	835	—Bennett Economical	926
—Quadruplex	834	—Tribune Newspaper	924
—Skeleton	834	—Unique Iron Frame	925
—Stereotype	837	Foot Sticks	836, 840
—Twin	835	Form Truck	836
—Twin, with Bars	835	Furniture	840, 841
—Wrought Iron	835	—Labor-saving	840
Chesapeake Economy Compound	889	—Metal	36
Circles, Wood	979	—Wood	840, 841
Combination Paper Jogger	923	Galley Brackets	830
Composing Rules	819	Galley Cabinets	831
Composing Stick Rack	820	Galley Lock-up	828
Composing Sticks	818, 819	Galley Proof Presses	868, 869
—Buckeye	818	Galley Racks	830
—"C" Slot	818	Galleys	826-829
—Common Screw	818	—All Brass	827
—Grover	818	—Lincoln	827
—Perfect News	819	—Linotype	828
—Standard Job	818	—Mailing	829
—Wooden Poster	819	—Patent Lined	826
—Yankee Job	818	—Smooth Lined	826
Copy Holder, Kelsey	820	—Success Riveted	827
Cord	817	—Unlined	829
Counters	885		
—American	885		

	PAGE		PAGE
Galleys— <i>Continued</i>		Linotype Planer	821
—With Lockup	828	Liquid Cement	971
—Wooden	829	Liquid Cement Brush	875
Gauge Pin Drawer	877	Liquid Overlay	891
Gauge Pins and Guides	877	Liquid Padding Glue	971
Gloss Varnishes	888	Lock-up Wrenches	837
Glue Pot	971	Lye Brushes	875
Gold Leaf Lettering Presses	960, 961	Magnifying Glass	975
Gripper Perforator, Miller's	896	Mailing Galleys	829, 973
Hack Saws	822	Mailing Machines	972-974
Hamilton Patent Cutting Stick	938	—Acme	973
Hand Rollers	892	—Horton	972
Handy Letter Board Cabinet	843	—McFatrigh	974
Handy Sort Cabinet	864	—Mustang	973
Handy Sort Drawers	864	—Rukenbrod	973
Hangers	923	Make-up Rules	819
Hempel Quoins	832	Make-up Tables	837
Hercules Liquid Overlay	891	Mallets	821
Hoke Engraving Plates	977	—Iron Bound	821
Tools for Engraving Hoke Plates	977	—Patent Rawhide	821
Ideal Inking Apparatus	910	—Rawhide-Rubber	821
Illustrations of Cases	848, 849	—Wooden	821
Imposing Surfaces, Iron	839	Maple Blocks	979
Imposing Tables and Stones	838, 839	Marble Stones	838
—Imposing Stones	838	Matrix Paper	976
—Iron Imposing Surfaces	839	Metallic Tape Couplers	875
—Make-up Tables	837	Miter Boxes	822
—With Letter Boards	839	Mitering Machines	824, 825
Indexing Machines	954	Monitor Job Backer	955
Inks	886-888	Monitor Punching and Indexing Machine	954, 955
Ink and Roller Cabinet	890	Monitor Table Shears	941
Ink Fountains	897	Monitor Wire Stitcher	948, 949
—Buckeye	897	Newspaper File	978
—Chandler & Price	897	Numbering Machines	882-884, 942, 943
(See also under respective Presses.)		—Bates' Automatic	942
Ink Knives	876	—Monitor	943
Inkoleum	889	—Paragon	942
Ink Reducers	889	—Wetter	882-884
—Chesapeake Economy Compound	889	Overhead Power Fixtures	923
—Inkoleum	889	Overlay Knife	876
Ink Slabs, Marble	839	Overlay, Liquid	891
Ink Slice	876	Padding Glue, Elastic	971
Iron Side and Foot Sticks	846	Padding Glue, Liquid	971
Interlocking Drying Racks, Kerner's	895	Page Cord	817
Job Backer	955	Paging Machines	942, 943
Kelsey Copy Holder	820	Pallet, Bookbinders' Lettering	959
Keystone Hack Saw	822	Pallet Ink Knives	876
Knife Grinders	939	Paper Box Cutting and Creasing Press	905
Knives	876	Paper Counter	971
—Ink	876	Paper Cutters	928-937
—Overlay	876	—Advance Lever	932
—St. John Paper	876	—Advance Power	933
—Tablet	876	—Challenge Lever	931
Label Holder	820	—Challenge Pony Lever	932
Lamp Holder	866	—Challenge Power	934
Lead and Rule Cases	846, 847	—Chandler & Price	931
Lead and Rule Cutters	823	—Clipper	930
—Chandler & Price	823	—Feister-Brown Self-Clamping	936, 937
—Handy	823	—Peerless Gem	928, 929
—Utility	823	—Peerless Power	934
Leader Boxes	822, 846	—Reliance Lever	932
Lead Racks	842	—Sheridan Power	935
Leather Belting	875	—Sheridan's Ideal	935
Letter-Board Cabinets	843	—Utility	930
Letter Boards	843	Paper Folders, Bone and Steel	876
Linotype Galley	828	Paper Jogger	923
		Paper Knife	876

	PAGE
Patent Cutting Stick	938
Perfection Wire Stitchers	950, 951
Perforators	896, 962-965
Planers	821
Power Fixtures	923
Press Boards	875, 969
—Bookbinders'	969
—Brass Bound	969
—Tympa	875
Press Points	879
Press Punches	879
Printers' Brushes	875
Printers' Dividers	822, 876
Printers' Eye Shade	817
Printers' Saw Table	867
Printers' Trucks	896
Printing Inks	886-888
Printing Presses	897-922
—Army	911
—Campbell Country Hand Cylinder	913
—Challenge Country Hand Cylinder	911
—Challenge Gordon	898
—Chandler & Price Gordon	897
—Cottrell Monarch	915
—Cottrell Paragon	916
—Cottrell Triumph	914
—Cranston Improved Book and News	918
—Cranston Improved Newspaper	918
—Cranston Improved Two-Roller	919
—Cranston Newspaper	917
—Cranston-Victor Commercial	921
—Cranston-Victor Two-Revolution	920, 922
—Gally Universal	900-903
—Golding Jobber	906
—Harris' Automatic	899
—Ideal Hand Cylinder	910
—Improved Country Prouty	912
—New Leverless Monona	912
—New Style Franklin Gordon	898
—Official Hand Lever	908
—Pearl	907
—Peerless	899
—Pilot Hand Lever	908
—Second-Hand	908
—Washington Hand	909
Proof Planers	821
Proof Presses	868, 869
Proof Rollers	892
Punching Machine	954, 955, 958
Pulleys	923
Quoin Lock	833
Quoins	832, 833, 840
—Mechanical	832, 833
—Wooden	840
Ratchets for Stereotype Blocks	881
Reducing Glass	975
Reducing Varnishes	888
Reglet, Labor-saving	840
Roller Cloth	874
Roller Composition	892
—Melting Kettle	893
Roller Supporters	893
Rollers	892
—Price for Casting	892
Round Corner Cutting Machines	954, 955
Rule Bender	824
Rule Cases	845-847

Rule Cutters	823
Rule Shaper	825
Ruling Machines	966, 967
Ruling Pens	967
Saws	822
Saw Table, Printers'	867
Screw Drivers	876
Script Type Cabinet	863
Shafting	923
Shooting Sticks	822, 876
Side Sticks	836, 840
Sort Drawers, Handy	864
Stabbing Machine, Hand	953
Stamping Presses	960, 961
Standing Galleys, Wood, etc.	870, 871
Standing Galleys, Wrought Iron	872
Standing Presses	968
Stands	852
Staple Binders	944-947
—Acme	944-946
—Breech Loader	947
—Hercules	947
—Sure Shot No. 1	946
—Other Staple Binders	947
Staples, Wire	945-947
Stereotype Blocks	880, 881
—Sectional Metal	881
Stereotype Casting Boxes	977
Stereotype Chases	837
Stereotyping Apparatus	976
Stitching Machines	948-951
—Monitor Automatic	948, 949
—Perfection	950, 951
—Tennis	953
Table Shears	941
Tablet Knife	876, 971
Tablet Presses	970
Tape	874
Tape Couplers	875
Tape Fastener	874
Tennis Book Sewing Machine	953
Thorne Type Setting Machine	873
Tint Blocks	979
Trucks	896
Tweezers	817
Tympa Press Boards	875
Type-high Gauge	866
Type-high Machine	867
Type Measures	820
Typesetting Machine	873
Type Wash, Eureka	800
Typographic Numbering Machines	882, 884
Varnishes	888
Wetter Numbering Machines	882-884
Wire, on Spools	951, 952
Wire Staples	945-947
Wire Stitchers	948-951
Wrapper Paster, Economy	974
Wrenches	876
Wooden Galleys	829
Wooden Shooting Sticks	876
Wood Furniture	840
Wood Pointers	794
Wood Rule	794
Wood Type	793-816
Wood-Type Case Rack	862

USEFUL INFORMATION

See pages 981 to 1024 for a variety of useful data, including *Imposition of Forms* and a *Price List of Printing and Binding*.

TYPE STANDARDS

The following is the standard adopted by the International Typographical Union. The basis of measurement is the lower-case alphabet, from a to z inclusive, and the ems used are the same body as the type measured :

	EMS
4½ Point	18
5 "	17
5½ "	16
6 "	15
7 "	14
8 "	14
9 "	13
10 "	13
11 "	13
12 "	13

HOW TO ESTIMATE

To ascertain the quantity of body type required for a publication, find the number of square inches and divide the same by four, and the quotient will be the approximate weight of type required ; but, as it is impossible to set the cases entirely clear, it is necessary to add 25 per cent. to the weight of large fonts, and 33½ per cent. to small fonts, to allow for dead letter.

NUMBER OF EMS IN ONE POUND OF TYPE

Two by two inches (four square inches) solid type weighs approximately one pound.

	EMS
5 Point	829
5½ "	685
6 "	576
7 "	423
8 "	324
9 "	256
10 "	207
11 "	171
12 "	144

HOW TO ORDER SORTS AND PREVENT ERRORS

In ordering sorts always inclose a metal cap *H* and lower-case *m* of the type you wish to match, and plainly state the quantity of each character required. Be sure and inclose sample before sealing envelope inclosing order. Better put sample in a small envelope. Avoid trouble and delay by being explicit. Order every article by the *exact name and number* given in the specimen book. Variations from the book names frequently cause error and delay. For instance: "Condensed Old Style" is not necessarily the same as "Old Style Condensed." *Do not mutilate* a specimen book. It does not help us to receive printed specimens taken from our specimen books. On the contrary, it retards the filling of an order, and it impairs the value of the book. In ordering, write each item on a separate line. Orders written in long paragraphs invite error. Separate the order from the accompanying letter. It will save time. As one man fills the order and another answers the letter, it is obvious that they cannot both work from the one document.

USEFUL IN ORDERING SORTS

The following table shows what each box in the type case will hold :

LETTERS.	WEIGHT IN FULL BOX.
a c d i s m n h o u t r	2 pounds.
f b l v g y p w	15 ounces.
k j z x q and all figures	6 ounces.
e	3 pounds.
Caps and Small Caps	5 ounces.

AMERICAN POINT SYSTEM

The following table gives the names of the old bodies and their new designation by points:

3½ Point	Brilliant.
4½ "	Diamond.
5 "	Pearl.
5½ "	Agate.
6 "	Nonpareil.
7 "	Minion.
8 "	Brevier.
9 "	Bourgeois.
10 "	Long Primer.
11 "	Small Pica.
12 "	Pica.
14 "	2-line Minion or English.
15 "	3-line Pearl
16 "	2-line Brevier.
18 "	Great Primer.
20 "	2-line Long Primer or Paragon.
22 "	2-line Small Pica.
24 "	2-line Pica.
28 "	2-line English.
30 "	5-line Nonpareil.
32 "	4-line Brevier.
36 "	2-line Great Primer.
40 "	Double Paragon.
42 "	7-line Nonpareil.
44 "	4-line Small Pica or Canon.
48 "	4-line Pica.
54 "	9-line Nonpareil.
60 "	5-line Pica.
72 "	6-line Pica.

PRICE LIST OF BODY TYPE

POINT BODIES.	25 LBS.	500 LBS.	1000 LBS.
	AND OVER.	AND OVER.	AND OVER.
	Per lb.	Per lb.	Per lb.
3½ Point	\$5 00
3½ " on 4½-Point	3 50
4½ "	1 60
5 "	1 20
5½ "	0 74	\$0 72	\$0 71
6 "	0 64	0 62	0 61
7 "	0 56	0 54	0 53
8 "	0 52	0 50	0 49
9 "	0 48	0 46	0 45
10 "	0 46	0 44	0 43
11 "	0 44	0 42	0 41
12 "	0 42	0 40	0 40
14 "	0 40
15 "	0 40
16 "	0 40
18 "	0 40

Roman and German Body Type is put up in fonts of 25, 50 and 100 pounds, or some multiple of these weights. Included in each 25 pounds are 5 pounds of Spaces and Quads, and same proportions in larger fonts.

Italic and Accents will not be sent with Roman fonts unless specially ordered. Smallest font of Italic furnished weighs 5 pounds. A pair of full-size cases holds 50 pounds of body type.

SPACES AND QUADS IN JOB FONTS

Spaces and Quads are also put up in assorted fonts of five pounds, at Body Type Prices, as below.

5 Point . \$1 40	12 Point . \$0 60	28 Point . \$0 55	54 Point . \$1 10
5½ " . 1 00	14 " . 0 60	30 " . 0 50	60 " . 1 15
6 " . 0 65	15 " . 0 60	32 " . 0 50	72 " . 1 25
7 " . 0 65	16 " . 0 55	36 " . 0 55	84 " . 0 90
8 " . 0 65	18 " . 0 55	40 " . 0 60	96 " . 1 70
9 " . 0 60	20 " . 0 60	42 " . 0 60	120 " . 1 40
10 " . 0 55	22 " . 0 50	44 " . 0 60
11 " . 0 60	24 " . 0 60	48 " . 0 80

ALLOWANCE FOR OLD TYPE AND OTHER METALS

Old type (clean and unmixed with other metals), electrotypes, leads and brass, delivered at foundry free, will be taken at current prices in even exchange for new type or printing material.

Customers sending in old metal are requested to mark their names on all packages, and to forward by mail a shipping receipt or bill of lading, with the net weight of each kind of material, as soon as shipment is made. Compliance with this request will aid in identifying shipments, and prevent errors. Ship as "old metal" to secure low freight rate.

SPECIAL NOTICE.—Zinc plates, metal containing zinc, or type and other plates mixed with zinc plates, and stereotype plates, will not be received at any price. Type, electrotype plates, leads and brass, must be packed separately, as the value of each differs.

Brass Type for Bookbinders

BRASS TYPE AND BORDERS AND ORNAMENTS

A special Specimen Book of Brass Type will be sent on application. The following series, or parts of them, shown in this Specimen Book, are made in Solid Brass :

	PAGE
Anglo-Saxon	441
Antique Condensed Nos. 122 and 116 (Caps)	206, 207
Antique Extra Condensed No. 150 (Caps)	208
Antique No. 125 (Caps)	202
Art Gothic	363
Atlanta	378
Condensed Aldine No. 150 (Caps)	193
Condensed No. 124	181
Edinburgh Title	157
Facade	372
French Old Style No. 1	159
Gothic Condensed No. 124 (Caps)	253
Gothic Extra Condensed No. 150 (Caps)	251
Gothic No. 127	245
Gothic No. 1510	247
Lafayette (Caps)	334
Latin Antique No. 120 (Caps)	234
Latin Condensed No. 150 (Caps)	232
Modern Antique (Caps)	230, 231
Mural	373
Norman Condensed	240
Novelty Script	451
Old Style Bold (Caps)	168
Old Style Extended (Caps)	165
Old Style No. 43	156
Two-Line No. 124	182
Two-Line No. 151	183
Victoria	379
Yonkers	446

Also, a Collection of Forty-five Beautiful Borders and
Thirty-nine Word Ornaments

BRASS RULES

In ordering Brass Rules it is important to state both No. and Initial. Unless otherwise noted, Brass Rules are made in 24-inch strips

No	BODY	PER FOOT
198E	1 Point	\$0 05
201E	1½ Point	6
203E	2 Point	8
206E	3 Point	12
207E	4 Point	16
500E	5 Point	20
208E	5½ Point	22
209E	6 Point	28
210E	7 Point	32
211E	8 Point	34
212E	9 Point	38
213E	10 Point	40
214E	11 Point	45
215E	12 Point	50
216E	1½ Point	6
218E	1½ Point	6
219E	2 Point	8
220E	2 Point	8
501E	1½ Point	6
502E	2 Point	8
503E	3 Point	12
504E	4 Point	16

No	BODY	PER FOOT
505E	5 Point	\$0 20
506E	6 Point	28
507E	7 Point	32
508E	8 Point	34
509E	9 Point	38
510E	10 Point	40
511E	11 Point	45
512E	12 Point	50
513E	1 Point	5
514E	1½ Point	6
515E	2 Point	8
516E	3 Point	12
517E	4 Point	16
518E	5 Point	20
519E	6 Point	28
520E	1½ Point	6
521E	2 Point	8
522E	3 Point	12
523E	4 Point	16
524E	5 Point	20
525E	6 Point	28

For Labor-Saving Brass Rules, see pages 28 and 29

No	BODY	PER FOOT
177E	1 Point	\$0 05
180E	1½ Point	6
182E	2 Point	8
185E	3 Point	12
187E	4 Point	16
189E	5 Point	20
191E	6 Point	28
192E	7 Point	32
193E	8 Point	34
194E	9 Point	38
195E	10 Point	40
196E	11 Point	45
197E	12 Point	50
197½E	18 Point	60
339½E	1½ Point	6
339E	2 Point	8
340½E	1½ Point	6
340E	2 Point	8
341½E	1½ Point	6
341E	2 Point	8
338½E	2 Point	8
342E	2 Point	8
343E	2 Point	8

No	BODY	PER FOOT
234E	2 Point	\$0 08
235E	3 Point	12
236E	3 Point	12
237E	4 Point	16
238E	5 Point	20
239E	5½ Point	22
240E	5½ Point	22
241E	8 Point	28
252E	4 Point	16
253E	5 Point	20
254E	5½ Point	22
255E	6 Point	28
245E	3 Point	12
246E	5 Point	20
247E	5½ Point	22
262E	3 Point	12
263E	4 Point	16
264E	5 Point	20
265E	5¼ Point	22
266E	6 Point	28
267E	7 Point	32
268E	8 Point	34
269E	9 Point	38

For Labor-Saving Brass Rules, see pages 28 and 29

No	BODY	PER FOOT
271E	4 Point	\$0 18
272E	4 Point	18
273E	5 Point	20
274E	5½ Point	22
275E	6 Point	28
276E	7 Point	32
281E	3 Point	12
282E	4 Point	16
283E	5 Point	20
284E	6 Point	28
285E	6 Point	28
286E	7 Point	32
287E	8 Point	34
288E	10 Point	40
289E	11 Point	45
290E	12 Point	50
290½E	2 Point	8
291E	3 Point	12
292E	4 Point	16
293E	5 Point	20
294E	5½ Point	22
295½E	5½ Point	22
296E	6 Point	28
297E	6 Point	28

No	BODY	PER FOOT
298E	8 Point	\$0 34
299E	9 Point	38
301E	10 Point	40
302E	11 Point	45
304E	12 Point	50
305E	18 Point	60
312E	5½ Point	22
313E	5 Point	20
314E	7 Point	32
316E	8 Point	34
317E	9 Point	38
319E	5 Point	20
320E	5½ Point	22
321E	5½ Point	22
322E	7 Point	32
323E	8 Point	34
324E	10 Point	40
325E	12 Point	50
326E	5 Point	20
327E	5½ Point	22
328E	7 Point	32

For Labor-Saving Brass Rules, see pages 28 and 29

No	BODY	PER FOOT
329E	8 Point	34
330E	9 Point	38
331E	10 Point	40
332E	7 Point	32
333E	9 Point	38
334E	11 Point	45
338E	9 Point	38
344E	2 Point	12
345E	2 Point	12
346E	2 Point	14
347E	3 Point	18
348E	4 Point	20
349E	5½ Point	28
350E	2 Point	14
351E	3 Point	18
352E	4 Point	20
353E	5½ Point	28
354E	1½ Point	10
355E	2 Point	14
356E	2 Point	14
357E	3 Point	18
358E	3 Point	18
359E	4 Point	20
360E	4 Point	20
361E	5½ Point	28
362E	5½ Point	28

No	BODY	PER FOOT
363E	2 Point	14
364E	2 Point	14
365E	2 Point	14
366E	2 Point	14
367E	2 Point	14
368E	2 Point	14
371E	2 Point	16
372E	2 Point	16
373E	2 Point	16
374E	2 Point	16
375E	2 Point	16
376E	4 Point	22
377E	4 Point	20
378E	5½ Point	28
380E	3 Point	18
382E	4 Point	22
383E	4 Point	20
385E	4 Point	22
386E	4 Point	20
387E	5½ Point	28
388E	5½ Point	28
389E	5½ Point	28
390E	5½ Point	28
392E	5½ Point	28
395E	6 Point	32

For Labor-Saving Brass Rules, see pages 28 and 29

No	BODY	PER FOOT
396E	5½ Point	\$0 30
399E	5½ Point	34
400E	5½ Point	32
401E	3 Point	18
402E	4 Point	20
404E	4 Point	20
406E	5½ Point	28
407E	5½ Point	28
408E	7 Point	36
409E	5½ Point	28
410E	7 Point	36
411E	7 Point	36
412E	8 Point	40
424E	7 Point	44
425E	9 Point	46
426E	11 Point	56
432E	5½ Point	30
433E	8 Point	42
434E	6 Point	36
435E	8 Point	42
436E	5 Point	22
437E	5 Point	22

No	BODY	PER FOOT
438½E	6 Point	\$0 36
439½E	6 Point	36
440½E	6 Point	36
441E	8 Point	42
442E	8 Point	42
443E	10 Point	48
444E	4 Point	22
445E	8 Point	42
447E	4 Point	22
448E	6 Point	36
449E	10 Point	48
450E	4 Point	22
452E	10 Point	48
454E	9 Point	48
455E	5½ Point	32
456E	4 Point	24
457E	5½ Point	32
470E	6 Point	36
280 B	12 Point	70
283 B	18 Point	75
284 B	18 Point	75

For Labor-Saving Brass Rules, see pages 28 and 29

No	BODY	PER FOOT
286 B	18 Point	80 75
288 B	18 Point	75
290 B	24 Point	1 25
291 B	24 Point	1 25
297 B	27 Point	1 40
308 B	2 Point	12
309 B	3 Point	18
310 B	4 Point	22
311 B	5 Point	27
312 B	6 Point	32
313 B	8 Point	42
314 B	12 Point	65
324 B	2 Point	12
325 B	3 Point	18
326 B	4 Point	22
327 B	5 Point	27
328 B	6 Point	32
329 B	8 Point	42
330 B	12 Point	65

No	BODY	PER FOOT
334 B	2 Point	12
335 B	3 Point	18
336 B	4 Point	22
337 B	5 Point	27
338 B	6 Point	32
339 B	8 Point	42
340 B	12 Point	65
342 B	18 Point	95
344 B	2 Point	12
345 B	3 Point	18
346 B	4 Point	22
347 B	5 Point	27
348 B	6 Point	32
349 B	8 Point	42
350 B	12 Point	65
352 B	18 Point	95
353 B	24 Point	1 25
405 B	12 Point	65
406 B	18 Point	95
407 B	24 Point	1 25

For Labor-Saving Brass Rules, see pages 28 and 29

No	BODY	PER FOOT
362 B	2 Point	\$0 12
363 B	3 Point	18
364 B	4 Point	22
365 B	5 Point	27
366 B	6 Point	32
367 B	8 Point	42
368 B	12 Point	65
369 B	15 Point	80
370 B	18 Point	95
371 B	24 Point	1 25
372 B	2 Point	12
373 B	3 Point	18
374 B	4 Point	22
375 B	5 Point	27
376 B	6 Point	32
377 B	8 Point	42
378 B	12 Point	65
379 B	15 Point	80
380 B	18 Point	95
381 B	24 Point	1 25

No	BODY	PER FOOT
382 B	2 Point	\$0 12
383 B	3 Point	18
384 B	4 Point	22
385 B	5 Point	27
386 B	6 Point	32
387 B	8 Point	42
388 B	12 Point	65
389 B	15 Point	80
390 B	18 Point	95
391 B	24 Point	1 25
566 B	6 Point	40
567 B	8 Point	50
568 B	12 Point	70
569 B	15 Point	90
570 B	18 Point	1 10
571 B	24 Point	1 25
572 B	30 Point	1 50
573 B	36 Point	1 75

For Labor-Saving Brass Rules, see pages 28 and 29

No	BODY	PER FOOT
443 B	2 Point	12
444 B	3 Point	18
445 B	4 Point	22
446 B	5 Point	27
447 B	6 Point	32
448 B	8 Point	42
449 B	12 Point	65

453 B	2 Point	12
454 B	3 Point	18
455 B	4 Point	22
456 B	5 Point	27
457 B	6 Point	32
458 B	8 Point	42
459 B	12 Point	65

463 B	2 Point	12
464 B	3 Point	18
465 B	4 Point	22
466 B	5 Point	27
467 B	6 Point	32
468 B	8 Point	42
469 B	12 Point	65

No	BODY	PER FOOT
470 B	2 Point	12
471 B	3 Point	18
472 B	4 Point	22
473 B	5 Point	27
474 B	6 Point	32
475 B	8 Point	42
476 B	12 Point	65

480 B	2 Point	12
481 B	3 Point	18
482 B	4 Point	22
483 B	5 Point	27
484 B	6 Point	32
485 B	8 Point	42
486 B	12 Point	65

490 B	2 Point	12
491 B	3 Point	18
492 B	4 Point	22
493 B	5 Point	27
494 B	6 Point	32
495 B	8 Point	42
496 B	12 Point	65

For Labor-Saving Brass Rules, see pages 28 and 29

No	BODY	PER FOOT
500 B	2 Point	10 12
501 B	3 Point	18
502 B	4 Point	22
503 B	5 Point	27
504 B	6 Point	32
505 B	8 Point	42
506 B	12 Point	65
507 B	15 Point	80
508 B	18 Point	95
509 B	24 Point	1 25
510 B	2 Point	12
511 B	3 Point	18
512 B	4 Point	22
513 B	5 Point	27
514 B	6 Point	32
515 B	8 Point	42
516 B	12 Point	65
587 B	12 Point	70
588 B	24 Point	1 25
589 B	36 Point	1 75

No	BODY	PER FOOT
523 B	2 Point	10 12
524 B	3 Point	18
525 B	4 Point	22
526 B	5 Point	27
527 B	6 Point	32
528 B	8 Point	42
529 B	12 Point	65
530 B	15 Point	80
531 B	18 Point	95
532 B	24 Point	1 25
533 B	2 Point	12
534 B	3 Point	18
535 B	4 Point	22
536 B	5 Point	27
537 B	6 Point	32
538 B	8 Point	42
539 B	12 Point	65
597 B	12 Point	70
598 B	24 Point	1 25
619 B	6 Point	40
620 B	6 Point	40

For Labor-Saving Brass Rules, see pages 28 and 29

No	BODY	PER FOOT
590 B	12 Point	\$0 70
591 B	24 Point	1 25
592 B	36 Point	1 75
593 B	6 Point	40
594 B	12 Point	70
595 B	15 Point	90
596 B	24 Point	1 25
980 F	6 Point	40
981 F	8 Point	50
982 F	9 Point	60
983 F	10 Point	65
984 F	12 Point	70
985 F	15 Point	90
986 F	18 Point	1 10
987 F	24 Point	1 25

No	BODY	PER FOOT
599 B	12 Point	\$0 70
600 B	24 Point	1 25
601 B	36 Point	1 75
615 B	12 Point	70
616 B	24 Point	1 25
617 B	24 Point	1 25
618 B	24 Point	1 25
980½ F	6 Point	40
981½ F	8 Point	50
982½ F	9 Point	60
983½ F	10 Point	65
984½ F	12 Point	70
985½ F	15 Point	90
986½ F	18 Point	1 10
987½ F	24 Point	1 25

Brass Rules with initial F are twelve inches long

No	BODY	PER FOOT
988 F	9 Point	\$0 60
989 F	12 Point	70
990 F	15 Point	90
991 F	18 Point	1 10
992 F	24 Point	1 25
993 F	30 Point	1 50
1036 F	6 Point	40
1037 F	12 Point	70
1038 F	18 Point	1 10
1039 F	24 Point	1 25
1040 F	30 Point	1 50

No	BODY	PER FOOT
988½ F	9 Point	\$0 60
989½ F	12 Point	70
990½ F	15 Point	90
991½ F	18 Point	1 10
992½ F	24 Point	1 25
993½ F	30 Point	1 50
1044 F	9 Point	60
1041 F	12 Point	70
1045 F	18 Point	1 10
1042 F	24 Point	1 25
1043 F	36 Point	1 75

Brass Rules with initial F are twelve inches long

PERFORATING RULES

700E, Brass.	2 Point.	Per foot, 15 cts.
701E, Brass.	3 Point.	Per foot, 18 cts.
710E, Steel.	17 teeth to 1 in.	Per foot, 50 cts.
711E, Steel.	12 teeth to 1 in.	Per foot, 50 cts.
712E, Steel.	8½ teeth to 1 in.	Per foot, 50 cts.

BRASS SCORING RULES

2 Point, per foot.	.08	4 Point, per foot.	.16
3 Point, per foot.	.12	6 Point, per foot.	.28

STEEL CUTTING RULES

2 Point, regular, per foot	.20
2 Point, bright and hard, per foot	.30
3 Point, regular, per foot	.30
6 Point, regular, per foot	.50

BRASS SPACE RULE

1 Point	Per pound, \$3.50
1½ Point	Per pound, 2.75
2 Point	Per pound, 2.00

LABOR-SAVING BRASS RULE

Labor-saving Brass Rules are cut in length to 12 Point body, unless otherwise ordered, and are graduated by ens and ems. All fonts have mitred corner pieces. Special prices on application for Labor-saving Ornamental Brass Rules

NO 340E

2 POINT

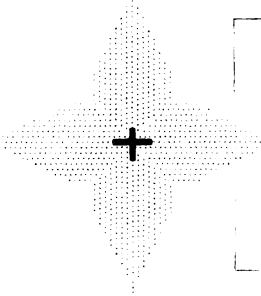

NO 203E

2 POINT

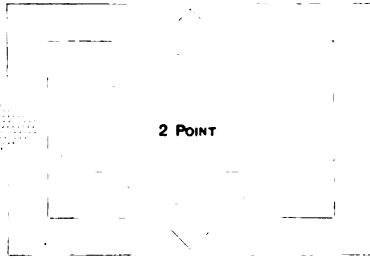

NO 341E

2 POINT

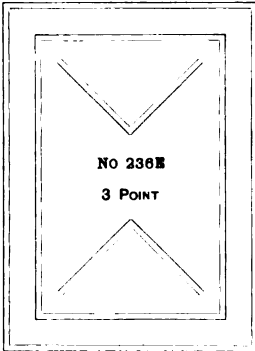
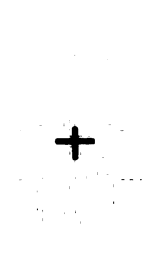

NO 210E
2 POINT

Prices of Labor-Saving Fonts

PT	NO	8-LB	3-LB	8-LB	10-LB
2	203	\$3 50	\$5 25	\$8 25	\$16 50
2	219	3 50	5 25	8 25	16 50
2	340	3 50	5 25	8 25	16 50
2	341	3 50	5 25	8 25	16 50
3	236	3 20	4 80	7 50	15 00
3	281	3 20	4 80	7 50	15 00
4	237	3 00	4 50	7 00	14 00
6	285	3 00	4 50	7 00	14 00
6	297	3 00	4 50	7 00	14 00

In ordering add the initial "E" to the above Nos.

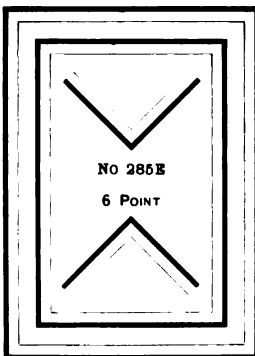
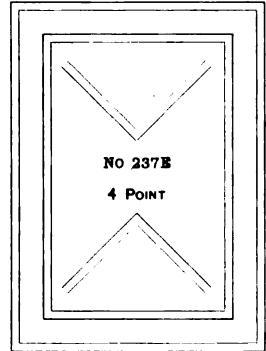

NO 281E
3 POINT

Price for Sorts

PER POUND

1 Point	. . . \$3 00
1½ Point	. . . 2 00
2 Point	. . . 1 75
3 Point	. . . 1 60
4 Point	. . . 1 50
6 Point	. . . 1 50
8 Point	. . . 1 50
10 Point	. . . 1 40

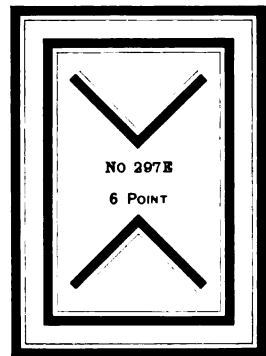

LABOR-SAVING BRASS RULE

17

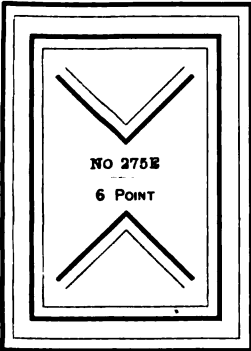
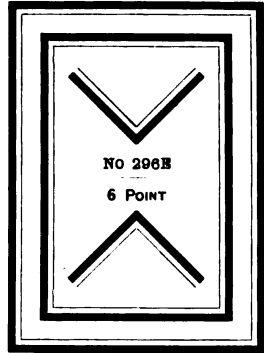
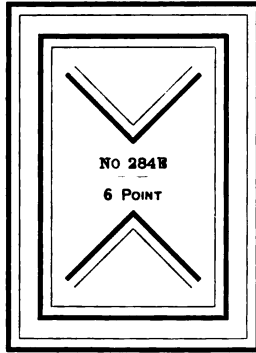
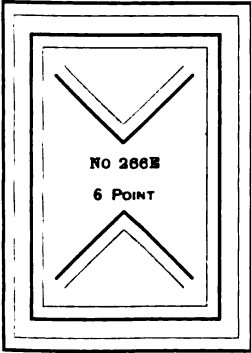

NO 282E
4 POINT

Prices of Labor-Saving Fonts

PT.	NO.	2-LB.	3-LB.	4-LB.	10-LB.
4	282	\$3 00	\$4 50	\$7 00	\$14 00
4	292	3 00	4 50	7 00	14 00
6	266	3 00	4 50	7 00	14 00
6	275	3 00	4 50	7 00	14 00
6	284	3 00	4 50	7 00	14 00
6	296	3 00	4 50	7 00	14 00
8	287	—	4 50	7 00	14 00
10	288	—	—	7 00	13 50
10	301	—	—	7 00	13 50

In ordering add the initial "E" to the above Nos.

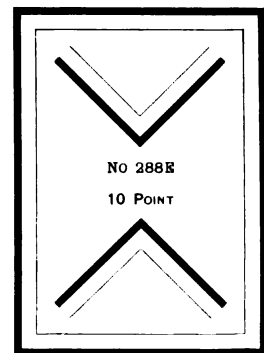
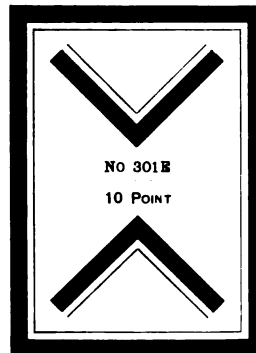
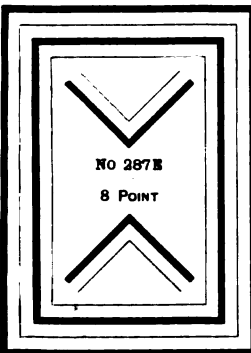
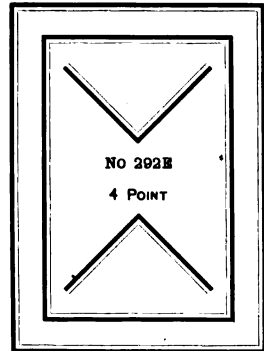

BRASS CIRCLES

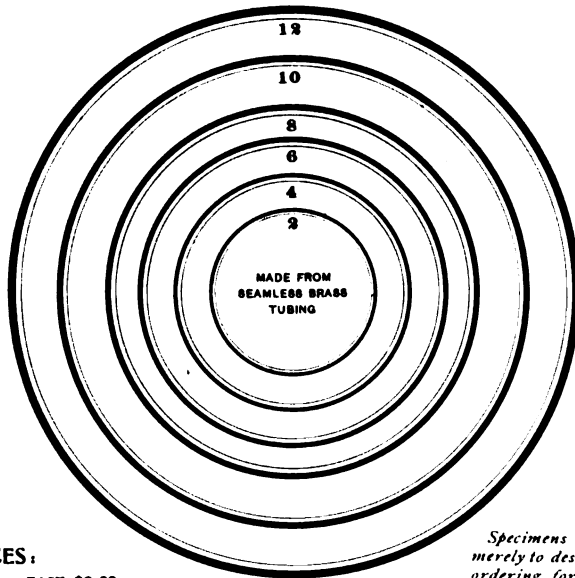

PRICES:

NOS. 1 TO 6	EACH	\$0.60
NOS. 7 TO 9	EACH	0.75
NOS. 10 TO 12	EACH	1.00
NO. 13	EACH	1.25

Specimens on this page are merely to designate Sizes. In ordering, for Size give the No. attached to Specimen, and for the Face give the No. from Specimens of Brass Rule in this book

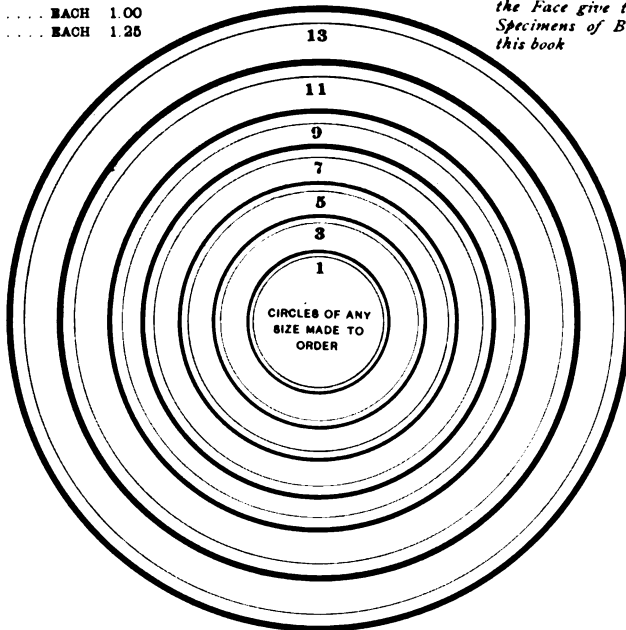

BRASS CIRCLES, DIAMONDS AND OVALS

Specimens on this page are merely to designate Sizes. In ordering, for Size give the No. attached to Specimen, and for the Face give the No. from Specimens of Brass Rule in this book

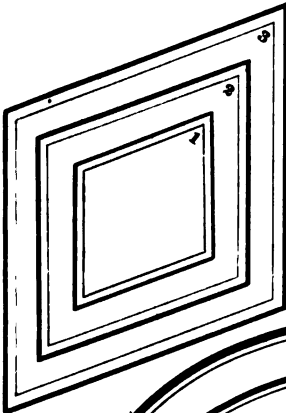
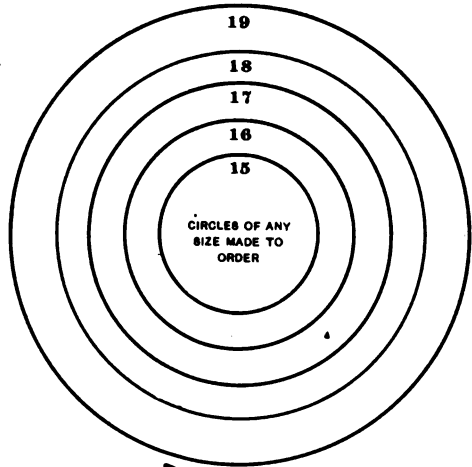
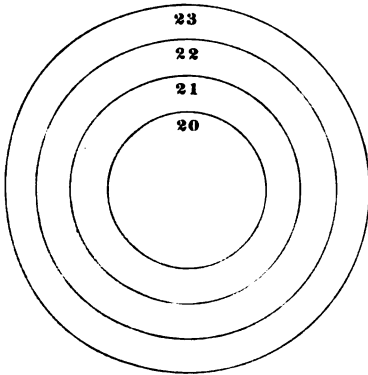

CIRCLES	
NO.	EACH
15 TO 17, AND 20 TO 22	\$0.60
18 AND 23	.75
19	1.00

DIAMONDS	
NO.	EACH
1 AND 2	.75
3, 5, 6 AND 7	1.00

OVALS	
NO.	EACH
4, 5 AND SMALLER	.90
6 AND 7	1.25

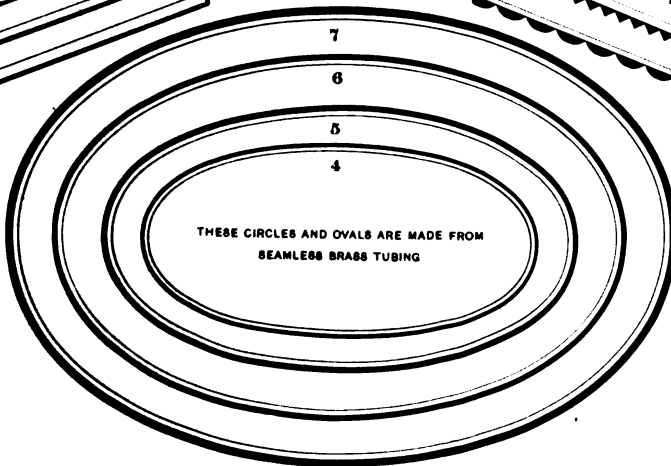
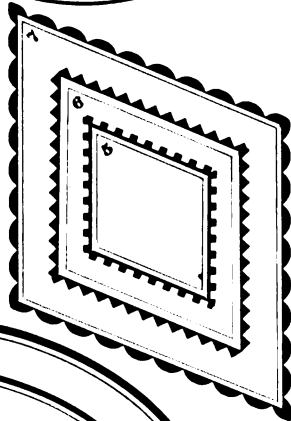

TABLE FOR NEWSPAPER ESTIMATES

[For other useful tables and general information, see pages 14 and 981 to 1008.]

Showing the number of ems of the different sizes of newspaper type in a line, the number of lines necessary to make one thousand ems, and the length in inches; the number of ems in the regular lengths of columns, and the number of leads required. There are 66 13-em 2-point leads in one pound.

ESTIMATED ON WIDTH OF STANDARD COLUMN, 13 EMS PICA.	8 1/2 POINT	6 POINT	7 POINT	8 POINT	9 POINT	10 POINT
Number ems in line	28 3/4	26	22 1/2	19 1/2	17 1/2	15 1/2
Number lines in 1000 ems	35 1/2	38 1/2	45	51 1/2	57 1/2	64 1/2
Number inches in 1000 ems	2 3/4	3 1/4	4 3/4	5 3/4	7 1/4	9
4-Column Folio or Quarto } number ems {	5040	4325	3175	2465	1950	1610
5-Column Folio or Quarto } in column {	6505	5615	4115	3200	2525	2085
6-Column Folio or Quarto }	7180	6160	4515	3510	2770	2290
7-Column Folio or Quarto }	7900	6785	4970	3865	3050	2520
8-Column Folio, number ems in column	8630	7410	5440	4220	3330	2755
9-Column Folio, number ems in column	9310	8030	5885	4575	3615	2970
2-point leads in 1000 ems of leaded matter	26	29	35	41	47	54
2-point leads in column, 4-column paper	132	124	110	99	90	82
2-point leads in column, 5-column paper	170	160	142	128	116	107
2-point leads in column, 6-column paper	190	178	158	142	129	119
2-point leads in column, 7-column paper	209	196	174	157	142	131
2-point leads in column, 8-column paper	221	207	184	166	151	138
2-point leads in column, 9-column paper	266	250	222	200	182	167
Weight of 2-point leads in 1000 ems of leaded matter	6 oz.	7 oz.	8 1/2 oz.	10 oz.	11 1/2 oz.	13 oz.
Weight of 2-point leads needed to lead 1000 ems of solid matter	8 1/2 oz.	9 1/2 oz.	11 oz.	12 1/2 oz.	14 oz.	16 oz.

STANDARD SIZES OF NEWSPAPERS

This table of sizes is based upon the standard sizes of newspapers, with columns 13 12-point ems wide and 6-point column rules. The adoption of these sizes is advisable especially in starting newspapers or putting in new outfits, thereby gaining desirable uniformity.

	Standard Size of Paper.	Size of Each Page.	Face Length of 6-pt. Col. Rules.	Length of Head Rules required.
	INCHES.	INCHES.	INCHES.	
4-Column Quarto	22 x 30	8 1/2 x 14	13 3/4	5 3/4 Pica ems.
5 " " " "	26 x 40	11 1/4 x 18	17 3/4	67 " " "
6 " " " "	30 x 44	13 3/8 x 20	19 3/4	80 1/2 " " "
7 " " " "	35 x 48	15 3/8 x 22	21 3/4	94 " " "
8 " " " "	40 x 52	17 1/2 x 24	23 3/4	107 1/2 " " "
5-Column Folio	20 x 26	11 1/4 x 18	17 3/4	67 " " "
6 " " " "	22 x 30	13 3/8 x 20	19 3/4	80 1/2 " " "
7 " " " "	24 x 35	15 3/8 x 22	21 3/4	94 " " "
8 " " " "	26 x 40	17 1/2 x 24	23 3/4	107 1/2 " " "
9 " " " "	28 x 44	20 1/4 x 26	25 3/4	121 " " "

* Length of column rules for first page determined by size of headings, or say about two inches shorter than full length.

BRASS COLUMN RULES

SIZE	FACE LENGTH	6 PT.	7 PT.	8 PT.	9 PT.	10 PT.
4-Col. Folio or Quarto	13 1/4 ins.	\$0.35	\$0.40	\$0.40	\$0.45	\$0.50
5-Col. Folio or Quarto	17 1/4 ins.	.40	.50	.50	.55	.60
6-Col. Folio or Quarto	19 1/4 ins.	.47	.55	.60	.65	.70
7-Col. Folio or Quarto	21 3/4 ins.	.50	.60	.65	.70	.75
8-Col. Folio or Quarto	23 3/4 ins.	.50	.65	.70	.75	.80
9-Col. Folio	25 3/4 ins.	.54	.70	.75	.80	.90
Each additional inch02	.03	.04	.05	.05

Column Rules nicked under for the use of Brass Reglet, 10 cents extra; nicked under and over for Perfecting Presses, 25 cents each extra.

BRASS LEADS AND SLUGS

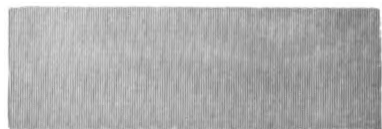

BODY	Cut Col. Measure	Cut L. S.
1-point, per pound	\$1.00	\$1.50
1 1/2 " " " "80	1.25
2 " " " "75	1.25
6 " " " " and thicker, per pound75	1.00

BRASS HEAD RULES

The following prices are for any Single, Double, Parallel or Triple Rule shown in this book :

BODY	4-COL	5-COL	6-COL	7-COL	8-COL	9-COL	BODY	4-COL	5-COL	6-COL	7-COL	8-COL	9-COL
3 Point	\$.15	\$.15	\$.20	\$.23	\$.25	\$.30	6 Point	\$.25	\$.30	\$.35	\$.40	\$.45	\$.50
4 Point	.15	.15	.20	.23	.25	.30	7 Point	.25	.30	.35	.40	.48	.55
5 Point	.15	.20	.23	.25	.30	.35	8 Point	.30	.35	.40	.45	.50	.60
5½ Point	.20	.22	.25	.30	.33	.40							

No 39D		4 Point
No 40D		5 Point
No 41D		6 Point
No 55D		4 Point
No 56D		5 Point
No 57D		6 Point
No 67D		7 Point
No 72D		4 Point
No 73D		5 Point
No 74D		6 Point
No 82D		5 Point
No 83D		6 Point
No 84D		7 Point

ADVERTISING RULES

Prices quoted are for columns 15 Pica ems wide and under.

	SINGLE COL 4 cts.	DOUBLE COL 6 cts.
No 13D		
No 99D	4 cts.	6 cts.
No 129D	5 cts.	8 cts.
No 132D	5 cts.	8 cts.
No 133D	5 cts.	8 cts.
No 36D	5 cts.	8 cts.
No 38D	6 cts.	10 cts.
No 39D	6 cts.	10 cts.
No 55D	6 cts.	10 cts.

	SINGLE COL 6 cts.	DOUBLE COL 10 cts.
No 72D		
No 73D	6 cts.	10 cts.
No 74D	6 cts.	10 cts.
No 65D	6 cts.	10 cts.
No 66D	6 cts.	10 cts.
No 82D	6 cts.	10 cts.
No 83D	6 cts.	10 cts.

BRASS DASH RULES

Cut to single column width, not exceeding 15 Pica ems.

	EACH
Style P	6 cts.
Style H	6 cts.
Style Q	6 cts.
Style A	6 cts.
Style B	6 cts.
Style C	7 cts.
Style D	8 cts.
Style E	8 cts.
Style F	8 cts.

	EACH
Style G	8 cts.
Style J	6 cts.
Style K	7 cts.
Style L	8 cts.
Style M	8 cts.
Style N	8 cts.
Style O	8 cts.
Style R	8 cts.

BRASS DASHES

No. 57E. 15 cts.		No. 45E. 10 cts.
No. 56E. 15 cts.		No. 44E. 10 cts.
No. 55E. 15 cts.		No. 43E. 10 cts.
No. 54½E. 15 cts.		No. 42E. 10 cts.
No. 54E. 15 cts.		No. 51E. 10 cts.
No. 53E. 15 cts.		No. 185F. 10 cts.
No. 52E. 15 cts.		No. 127F. 10 cts.
No. 48E. 10 cts.		No. 166F. 10 cts.
No. 47E. 10 cts.		No. 171F. 10 cts.
No. 32E. 10 cts.	No. 21E. 10 cts.	No. 10E. 10 cts.
No. 29E. 10 cts.	No. 22E. 10 cts.	No. 13E. 10 cts.
No. 16E. 10 cts.	No. 12E. 10 cts.	No. 7E. 10 cts.
No. 18E. 10 cts.	No. 15E. 10 cts.	No. 27E. 10 cts.
No. 24E. 10 cts.	No. 9E. 10 cts.	No. 24½E. 10 cts.
No. 23E. 10 cts.	No. 11E. 10 cts.	No. 17E. 10 cts.
No. 14E. 10 cts.		No. 19E. 10 cts.
No. 60E. 15 cts.	No. 2E. 10 cts.	
No. 63E. 15 cts.	No. 3E. 10 cts.	
No. 52E. 15 cts.	No. 1E. 10 cts.	
No. 57E. 15 cts.	No. 5E. 10 cts.	
No. 47E. 10 cts.	No. 6E. 10 cts.	
No. 48E. 10 cts.	No. 13E. 10 cts.	
No. 42E. 10 cts.	No. 31E. 10 cts.	
No. 39E. 10 cts.	No. 28E. 10 cts.	
No. 110F. 10 cts.	No. 33E. 10 cts.	
No. 30E. 10 cts.	No. 101F. 10 cts.	
No. 113F. 10 cts.	No. 172F. 10 cts.	
No. 198F. 10 cts.	No. 38E. 10 cts.	
No. 150F. 10 cts.	No. 36E. 10 cts.	
No. 186F. 10 cts.	No. 41E. 10 cts.	
	No. 34E. 10 cts.	
No. 59E. 15 cts.		
No. 62E. 15 cts.		
No. 58E. 15 cts.		
No. 61E. 15 cts.		
No. 212D. 25 cts.		

BRASS JOB DASHES

2 Point body, sc. each. Length of face and body is here shown. Can be cut shorter, if so ordered

No. 1A
No. 2A
No. 3A
No. 4A
No. 5A
No. 6A
No. 7A
No. 8A
No. 9A
No. 10A
No. 11A
No. 12A
No. 13A
No. 14A
No. 15A
No. 16A
No. 17A
No. 18A
No. 19A
No. 20A
No. 21A
No. 22A

All Brass Dashes that are sold for 10 cents each supplied any length for News Columns not exceeding 15 ems Pica

BRASS BRACES

COMPLETE SET \$5 60

The superiority of a Brace cut out of solid Brass to one electrotyped from these Brass Braces is obvious, and those who furnish electrotyped Braces charge quite as much for them as we charge for these original Brass Braces.

No. 32. 30 cts.		
No. 31. 30 cts.		
No. 30. 30 cts.		
No. 29. 30 cts.		
No. 28. 30 cts.		
No. 27. 25 cts.		
No. 26. 25 cts.		
No. 25. 25 cts.		
No. 24. 25 cts.		
No. 23. 25 cts.		
No. 22. 18 cts.		
No. 21. 18 cts.		
No. 20. 18 cts.		
No. 19. 18 cts.		
No. 18. 18 cts.		
No. 17. 15 cts.		
No. 16. 15 cts.		
No. 15. 15 cts.		
No. 14. 15 cts.		
No. 13. 15 cts.		
No. 12. 15 cts.		
No. 11. 15 cts.		
No. 10. 12 cts.		
No. 9. 12 cts.		
No. 8. 12 cts.		
No. 7. 12 cts.		
No. 6. 12 cts.		
No. 5. 12 cts.		
No. 4. 12 cts.		
No. 3. 12 cts.		
No. 2. 12 cts.		
No. 38. 12 cts.		
No. 37. 12 cts.		
No. 36. 12 cts.		
No. 35. 12 cts.		
No. 34. 12 cts.		
No. 33. 12 cts.		
No. 1. 12 cts.		

LABOR-SAVING BRASS LEADERS

5 Point body.	Faces.	DOTTED OR HYPHEN, from 12 Points to 216 Points in length.	Per lb.	9 Point body.	Faces.
	5 Point	\$1 60	
5½ Point body.	5½ "	1 60	10 Point body.
6 Point body.	6 "	1 60	
7 Point body.	7 "	1 60	11 Point body.
	8 "	1 60	
8 Point body.	9 "	1 50	12 Point body.
	10 "	1 50	
		11 "	1 40		
		12 "	1 40		

When ordering, be particular to state the style of Leader (whether Dotted or Hyphen) as well as the face of the type with which the Leaders are to be used, and send a cap H and lower case m, so that exact line may be assured.

METAL FURNITURE 12

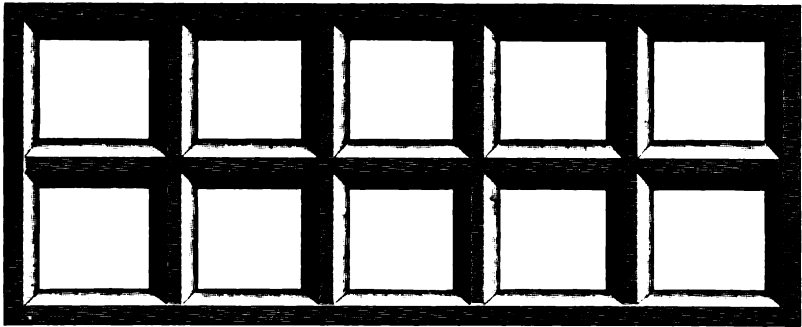

Put up in fonts containing the following sizes: 2, 3, 4, 5, 6, 8 and 10 ems Pica wide, and 4, 5, 6, 8, 10, 15, 20, 25, 30 and 50 ems Pica long.

12 pound font	\$ 3 00
25 pound font	6 25
50 pound font	12 50
100 pound font	25 00

Sorts, 25 cents per pound.

Attention is invited to the new design of this furniture. The strain-bearing braces have been increased in number and placed in the best possible positions, increasing the strength while not increasing the weight.

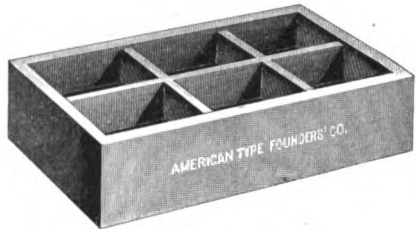

LABOR-SAVING QUOTATION FURNITURE 12 15

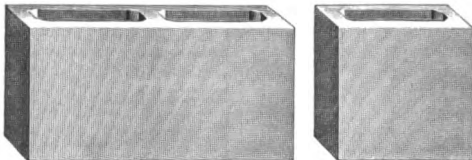

Finished with the strictest regard for accuracy. Made 2, 3 and 4 ems Pica wide, and 4, 8, 12, 16 and 20 ems Pica long.

12 pound font	\$ 3 00
25 pound font	6 25
50 pound font	12 50
100 pound font	25 00

Sorts, 25 cents per pound.

Additional sizes, 2 x 5, 2 x 6, 3 x 5, 3 x 6, 4 x 5, 4 x 6, 5 x 5, 5 x 6 and 6 x 6, cast accurately to Pica ems, per pound, 25 cents.

REVERSIBLE METAL FURNITURE 12

This Labor-Saving Reversible Furniture is our invention, and is unsurpassed for its strength and accuracy. It is made on the Point System of Bodies, and is useful for making up and blanking out forms and for general imposition. It is cast in lengths of 16 1/2 inches, and 2, 3, 4, 5, 6, 8, 9 and 10 ems Pica wide, and is cut to such lengths as may be ordered. Not put up in fonts.



Price, per pound, cut to measure, 25 cents.

LABOR-SAVING LEADS AND SLUGS

2 Point or thicker, in fonts of graduated lengths, from 48 Points and upward.

12-pound font	\$3 00
20-pound font	5 00
25-pound font	6 25
50-pound font	12 50
100-pound font	25 00
Sorts, per pound	25

SHAVED LEADS AND SLUGS

	Uncut.	Cut to one Meas.
1 Point (12-to-Pica), per lb.	\$0 50	\$0 65
1½ Point (10-to-Pica), per lb.	40	50
1¾ Point (8-to-Pica), per lb.	32	40
2 Point (6-to-Pica), per lb.	16	18
3 Point (4-to-Pica), per lb.	16	18
4 Point (3-to-Pica), per lb.	16	18
6 Point (Nonpareil), Slugs, per lb.	16	18
8 Point (Brevier), Slugs, per lb.	16	18
9 Point (Bourgeois), Slugs, per lb.	16	18
10 Point (L. Primer), Slugs, per lb.	16	18
12 Point (Pica), Slugs, per lb.	16	18
18 Point (G. Primer), Slugs, per lb.	16	18

COPPER ALLOY TAKE SLUGS

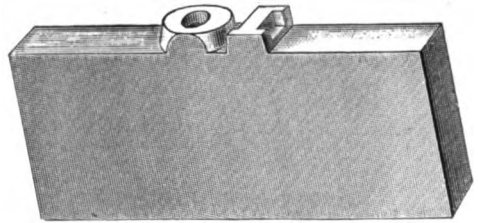

The only Take Slug cast in a mould in extra durable copper alloy metal. Better, cheaper and more durable than electrotyped slugs. Any number, from 1 to 100, in this style figure only:

1 2 3 4 5 6

Price, each, 15 cents.

ELECTROTYPED TAKE SLUGS

With Word, Letter or Figure \$0 15

METAL CORNER QUADS

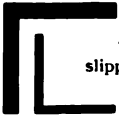

These insure a better junction of mitered corners, by preventing them from slipping past each other.

6, 10, or 12 Point, per set of four	\$0 15
3 Point, Brass, per set of four	15



ANGULAR QUADS

These Quads, introduced by us, are for setting rules and lines at an angle. When there is occasion for their use they are invaluable time-savers. They are of ordinary space and quad height.

Fonts, four of all sizes	\$1 50
Per set of four:	
12 Point	20
15 Point	20
24 Point	20
36 Point	25
48 Point	30
60 Point	35
72 Point	40

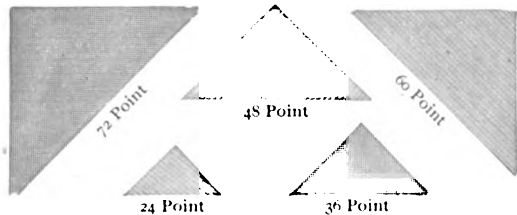

CIRCULAR QUADS

Each font is put up in a wooden box, containing four pieces each of twenty different curves. Each curve mortised as shown in examples.

Price, per font \$3.50

SYNOPSIS OF ROMAN BODY TYPE

All sizes are spaced uniformly with 3-to-em spaces

Series No.

3½ POINT MODERN ROMAN

17—When, in the course of human events, it becomes necessary for one people to dissolve the political bands which have connected them with another, and to assume, unto

4½ POINT MODERN ROMAN

18—When, in the course of human events, it becomes necessary for one people to dissolve the political bands which have connected them with another, and to assume

17—When, in the course of human events, it becomes necessary for one people to dissolve the political bands which have connected them with another

5 POINT MODERN ROMAN

45—When, in the course of human events, it becomes necessary for one people to dissolve the political bands which

57—When, in the course of human events, it becomes necessary for one people to dissolve the political bands

46—When, in the course of human events, it becomes necessary for one people to dissolve the political

5 POINT OLD STYLE ROMAN

79—When, in the course of human events, it becomes necessary for one people to dissolve the political bands which have c

5½ POINT MODERN ROMAN

62—When, in the course of human events, it becomes necessary for one people to dissolve the political band.

47—When, in the course of human events, it becomes necessary for one people to dissolve the political band

57—When, in the course of human events, it becomes necessary for one people to dissolve the political

46—When, in the course of human events, it becomes necessary for one people to dissolve the political

49—When, in the course of human events, it becomes necessary for one people to dissolve the political

45—When, in the course of human events, it becomes necessary for one people to dissolve the political

58—When, in the course of human events, it becomes necessary for one people to dissolve the political

19½—When, in the course of human events, it becomes necessary for one people to dissolve the political

56—When, in the course of human events, it becomes necessary for one people to dissolve the political

5½ POINT OLD STYLE ROMAN

80—When, in the course of human events, it becomes necessary for one people to dissolve the political bands

6 POINT MODERN ROMAN

116—When, in the course of human events, it becomes necessary for one people to dissolve the political

20½—When, in the course of human events, it becomes necessary for one people to dissolve the political

47½—When, in the course of human events, it becomes necessary for one people to dissolve the political

50—When, in the course of human events, it becomes necessary for one people to dissolve the political

57—When, in the course of human events, it becomes necessary for one people to dissolve the political

62—When, in the course of human events, it becomes necessary for one people to dissolve the political

49—When, in the course of human events, it becomes necessary for one people to dissolve the political

46—When, in the course of human events, it becomes necessary for one people to dissolve the political

45—When, in the course of human events, it becomes necessary for one people to dissolve the political

61—When, in the course of human events, it becomes necessary for one people to dissolve the political

58—When, in the course of human events, it becomes necessary for one people to dissolve the political

37½—When, in the course of human events, it becomes necessary for one people to dissolve the political

56—When, in the course of human events, it becomes necessary for one people to dissolve the political

6 POINT OLD STYLE ROMAN

71—When, in the course of human events, it becomes necessary for one people to dissolve the political bands n

82—When, in the course of human events, it becomes necessary for one people to dissolve the political bands

*—When, in the course of human events, it becomes necessary for one people to dissolve the political b†

†—When, in the course of human events, it becomes necessary for one people to dissolve the political b†

83—When, in the course of human events, it becomes necessary for one people to dissolve the political ps

74—When, in the course of human events, it becomes necessary for one people to dissolve the political theo

72—When, in the course of human events, it becomes necessary for one people to dissolve the political three

27—When, in the course of human events, it becomes necessary for one people to dissolve the political

†—When, in the course of human events, it becomes necessary for one people to dissolve the political d

SYNOPSIS OF ROMAN BODY TYPE—*Continued**All sizes are spaced uniformly with 3-to-em spaces*

7 POINT MODERN ROMAN

Series No.

- 47—When, in the course of human events, it becomes necessary for one people to dissolvn
 23½—When, in the course of human events, it becomes necessary for one people to dissolve
 62—When, in the course of human events, it becomes necessary for one people to dissolvi
 69—When, in the course of human events, it becomes necessary for one people to disso
 57—When, in the course of human events, it becomes necessary for one people to dissi
 50—When, in the course of human events, it becomes necessary for one people to diss
 49—When, in the course of human events, it becomes necessary for one people to din
 58—When, in the course of human events, it becomes necessary for one people to dis
 45—When, in the course of human events, it becomes necessary for one people to ds
 61—When, in the course of human events, it becomes necessary for one people to dr
 46—When, in the course of human events, it becomes necessary for one people to s
 38½—When, in the course of human events, it becomes necessary for one people tos
 56—When, in the course of human events, it becomes necessary for one peopleo

7 POINT OLD STYLE ROMAN

- 82—When, in the course of human events, it becomes necessary for one people to dissolve thw
 83—When, in the course of human events, it becomes necessary for one people to dissolvie
 *—When, in the course of human events, it becomes necessary for one people to dissolvi
 72—When, in the course of human events, it becomes necessary for one people to din

8 POINT MODERN ROMAN

- ¶—When, in the course of human events, it becomes necessary for one people to dissolve i
 47—When, in the course of human events, it becomes necessary for one people to s
 18½—When, in the course of human events, it becomes necessary for one people tw
 45—When, in the course of human events, it becomes necessary for one people o
 57—When, in the course of human events, it becomes necessary for one people i
 61—When, in the course of human events, it becomes necessary for one people i
 49—When, in the course of human events, it becomes necessary for one people r
 50—When, in the course of human events, it becomes necessary for one people i
 62—When, in the course of human events, it becomes necessary for one people
 58—When, in the course of human events, it becomes necessary for one people
 69—When, in the course of human events, it becomes necessary for one people
 46—When, in the course of human events, it becomes necessary for one people
 48½—When, in the course of human events, it becomes necessary for one people
 56—When, in the course of human events, it becomes necessary for one people

8 POINT OLD STYLE ROMAN

- 71—When, in the course of human events, it becomes necessary for one people to dissolve the polits
 †—When, in the course of human events, it becomes necessary for one people to dissol
 82—When, in the course of human events, it becomes necessary for one people to disso
 ‡—When, in the course of human events, it becomes necessary for one people to disso
 *—When, in the course of human events, it becomes necessary for one people to diso
 ¶—When, in the course of human events, it becomes necessary for one people to o
 22—When, in the course of human events, it becomes necessary for one people toi
 72—When, in the course of human events, it becomes necessary for one people to
 74—When, in the course of human events, it becomes necessary for one people t
 83—When, in the course of human events, it becomes necessary for one peoplee
 †—When, in the course of human events, it becomes necessary for one peoplee

* French Old Style No. 2
 † Caxton Old Style

‡ French Elzevir No. 1
 § Cushing

¶ Century Roman
 § Cushing Monotone

SYNOPSIS OF ROMAN BODY TYPE—*Continued**All sizes are spaced uniformly with 3-to-em spaces*

9 POINT MODERN ROMAN

Series No.

- ¶—When, in the course of human events, it becomes necessary for one people im
 47—When, in the course of human events, it becomes necessary for one peo
 32½—When, in the course of human events, it becomes necessary for one po
 45—When, in the course of human events, it becomes necessary for one pe
 57—When, in the course of human events, it becomes necessary for one pe
 58—When, in the course of human events, it becomes necessary for one io
 69—When, in the course of human events, it becomes necessary for one it
 50—When, in the course of human events, it becomes necessary for one
 61—When, in the course of human events, it becomes necessary for ons
 56—When, in the course of human events, it becomes necessary for it
 46—When, in the course of human events, it becomes necessary fort

9 POINT OLD STYLE ROMAN

- 71—When, in the course of human events, it becomes necessary for one people to dr
 82—When, in the course of human events, it becomes necessary for one people ti
 72—When, in the course of human events, it becomes necessary for one per
 83—When, in the course of human events, it becomes necessary for one po
 28—When, in the course of human events, it becomes necessary for one po

10 POINT MODERN ROMAN

- ¶—When, in the course of human events, it becomes necessary for one pf
 47—When, in the course of human events, it becomes necessary for o
 57—When, in the course of human events, it becomes necessary for o
 58—When, in the course of human events, it becomes necessary fori
 45—When, in the course of human events, it becomes necessary foi
 17½—When, in the course of human events, it becomes necessary fis
 50—When, in the course of human events, it becomes necessary fs
 56—When, in the course of human events, it becomes necessary fi

10 POINT OLD STYLE ROMAN

- 71—When, in the course of human events, it becomes necessary for one people t
 ¶—When, in the course of human events, it becomes necessary for one pes
 82—When, in the course of human events, it becomes necessary for one pe
 †—When, in the course of human events, it becomes necessary for one pe
 29—When, in the course of human events, it becomes necessary for one pe
 ‡—When, in the course of human events, it becomes necessary for ones
 *—When, in the course of human events, it becomes necessary for on
 72—When, in the course of human events, it becomes necessary for ol
 74—When, in the course of human events, it becomes necessary for oi
 83—When, in the course of human events, it becomes necessary foo
 24—When, in the course of human events, it becomes necessary fo
 x—When, in the course of human events, it becomes necessary fr
 †—When, in the course of human events, it becomes necessit

* French Old Style No. 2 † French Elzevir No. 1 ‡ Century Roman x Cushing Monotone No. 2
 † Caxton Old Style ‡ Cushing ‡ Cushing Monotone

SYNOPSIS OF ROMAN BODY TYPE—*Continued**All sizes are spaced uniformly with 3-to-em spaces*

11 POINT MODERN ROMAN

- 58—When, in the course of human events, it becomes necessary
 47—When, in the course of human events, it becomes necessae
 21½—When, in the course of human events, it becomes necei

11 POINT OLD STYLE ROMAN

- 71—When, in the course of human events, it becomes necessary for one
 ‡—When, in the course of human events, it becomes necessary forit
 82—When, in the course of human events, it becomes necessary for i
 25—When, in the course of human events, it becomes necessary flt
 72—When, in the course of human events, it becomes necessary fo
 74—When, in the course of human events, it becomes necessary i
 83—When, in the course of human events, it becomes necesi

12 POINT MODERN ROMAN

- 45—When, in the course of human events, it becomes necei
 31½—When, in the course of human events, it becomes necei
 58—When, in the course of human events, it becomes ned
 47—When, in the course of human events, it becomes ns

12 POINT OLD STYLE ROMAN

- 71—When, in the course of human events, it becomes necessali
 82—When, in the course of human events, it becomes necessit
 †—When, in the course of human events, it becomes necesu
 ‡—When, in the course of human events, it becomes necesy
 72—When, in the course of human events, it becomes neces-
 26—When, in the course of human events, it becomes necei
 74—When, in the course of human events, it becomes necn
 *—When, in the course of human events, it becomes nect
 83—When, in the course of human events, it becomesr
 †—When, in the course of human events, it becomes

* French Old Style No. 2
 † Caxton Old Style

‡ French Elzevir No. 1
 † Cushing

‡ Cushing Monotone

TIME-SAVING MAIL LIST TYPE	MAIL LIST TYPE	MAIL LIST TYPE
Example, used without Logotypes	Example, in combination with Mail List Logotypes to Point No. 122	Example, in combination with Mail List Logotypes to Point No. 114 and to Point Clarendon No. 126
Theo. L. DeVinne 12Jan92 NEW YORK, N. Y.	Dr Chauncey Depew 3 Oct 91	CORNCOB GULCH Rose Smith 17799
J. S. Cushing 30Mar72 BOSTON, MASS.	Mrs Mary Walker 31 Mar 83	SQUABTOWN K L Ondike 23 90
Sherman Bros. 11Sep73 PHILADELPHIA, PA.	Mr James J. Corbett 3 Jan 96	Yukon Mining Co 4 73
Pope Bicycle Co. 6Aug95 HARTFORD, CONN.	Rev Abe Slupsky 30 Nov 98	I X L Mauser 22 88
Bureau of Engraving, WASHINGTON, D. C.	James J. Blaine 3 Feb 89	SAN JUAN PORT Nelson A Miles 18 86
	Theo. Roosevelt 4 Apr 79	Wm L Churchill 23 96
	Miss B. Hesselberg 3 Dec 95	Clara Barton 27 81
	Dr Dora Bloomer 12 May 95	Weekly Sentinel 23 92
		HUNGRY HILL Western Gazette 10743
		Katy Reagan 7734

The above Mail List Type, with Logotypes, is furnished at the regular rates of Roman for spacing. By setting stakes to a multiple of 10 points, the cost of being more clearly legible is not increased. Although the face is large, an example is given for the first Time-Saving Mail List Type is quite as condensed on the average as ordinary Mail List Type. Price, same as for 10 Point Roman.

TIME-SAVING MAIL LIST TYPE	MAIL LIST TYPE	MAIL LIST TYPE
Example, used without Logotypes	Example, in combination with Mail List Logotypes to Point No. 122	Example, in combination with Mail List Logotypes to Point No. 114 and to Point Clarendon No. 126
8 POINT EM SET NO 150	10 POINT EM SET NO 123	10 POINT EM SET NO 120
Jan Feb Mar Apr May Jun Jul Aug Sep Oct Nov Dec	Jan Feb Mar Apr May June July Aug Sep Oct Nov Dec	Jan Feb Mar Apr May Jun Jul Aug Sep Oct Nov Dec
Cast also on a Point em set body	96 Mr Mrs Miss Box Dr Rev Esq 97	10 POINT EM SET NO 114
10 POINT EM SET NO 121	10 POINT EM SET NO 123	9 POINT EM SET NO 150
Jan Feb Mar Apr May Jun Jul Aug Sep Oct Nov Dec	Mr Mrs Miss Box Dr Rev Esq 97	10 POINT EM SET NO 114
1234567890	10 POINT EM SET NO 123	10 POINT EM SET NO 114
Figures on 4-to-em set	10 POINT EM SET NO 123	10 POINT EM SET NO 114

Sold at Roman prices. These Logotypes may be used with any Series of Mail List Type

TIME-TABLE FIGURES

8 POINT WHITEFACE FIGURES NO 151
PER LB. \$1 60

Lv.	CHICAGO	Ar	2 48
Ar.	Galesburg	Lv	10 16
Lv.	Galesburg	Ar	10 22
	Abingdon		9 49
	St. Augustine		9 37
	Avon		
	Prairie City		9 22
	Bushnell		9 12
	Bardolph		9 02
	Macomb		8 49
	Colchester		8 33
	Tennessee		8 29
	Colmar		8 22
	Plymouth		8 12

6 POINT WHITEFACE FIGURES NO 152
PER LB. \$3 00

7 23	0	Lv.	LOUISVILLE	Ar	123
7 32	74		Huntington		47
7 43	80		Ferdinand		41
7 59	85		Dale		37
8 07	88		Lincoln		33
8 14	91		Gentryville		29
8 17	93		Pigeon		26
8 22	96		Tennessee		22
8 30	201		De Gonia		17
8 36	105		Boonville		13
8 40	114		Dawson		7
8 55	118		Stevenson		4
11 59	122		Evansville		0

9 POINT NO 31 LIGHTFACE PER LB 90 OTS 8 POINT NO 32 HEAVYFACE

11 48	Lv.	ST. LOUIS	Ar	3 45
12 15		Alton		3 10
		Texas Junction		2 45
2 12		Clarksville		1 15
2 32		Louisiana		12 55
3 15	Ar.	Hannibal	Lv	12 12
3 55	Lv.	Hannibal	Ar	10 49
4 42		Palmyra		10 12
4 59		Ely		9 49
5 12		Monroe		9 36
5 25		Hunnewell		9 24
5 35		Lakenan		9 12
5 46		Shelbina		8 46
6 31		Macon		8 22

6 POINT NO 31 LIGHTFACE PER LB \$1 18 6 POINT NO 32 HEAVYFACE

8 07	0	Lv.	LOUISVILLE	Ar	273	5 42
8 27	6		New Albany		267	5 22
8 39	12		Edwardsville		261	5 07
8 47	15		Georgetown		258	4 59
9 00	21		Crandall		252	4 47
	22		Mott		251	
9 06	23		Corydon Junction		249	4 43
9 13	26		Ramseys		246	4 35
9 20	31		De Pauw		243	4 28
9 31	33		Milltown		239	4 20
9 40	38		Marengo		235	4 11
9 52	42		Temple		237	4 02
10 00	45		English		228	3 55

7 POINT NO 31 LIGHTFACE PER LB \$1 00 7 POINT NO 32 HEAVYFACE

6 35	Lv.	ST. LOUIS	Ar	5 20
8 53		East St. Louis		5 00
9 35		Upper Alton		4 14
9 55		Brighton		3 55
10 05		Piasa		3 43
10 15		Medora		3 33
10 45		Greenfield		3 05
10 55		Wrights		2 55
11 10		Whitehall		2 39
11 20		West Roodhouse		2 27
11 47		Winchester		2 01
12 01		Riggston		1 49
12 12		Chapin		1 34
1 10		Beardstown		1 07
1 34		Browning		12 46
2 10		Vermont		12 12
2 20		Table Grove		11 43

5 1/2 POINT NO 31 LIGHTFACE PER LB \$1 44 5 1/2 POINT NO 32 HEAVYFACE

8 30	0	Lv.	PLEASANT HILL	Ar	133	5 50
8 52	10		Harrisonville		123	5 25
9 23	23		Archle		110	4 57
9 38	29		Audran?		104	4 43
9 58	39		Butler		94	4 22
10 21	48		Ovid		85	
10 26	50		Rich Hill		83	3 55
10 40	56		Arthur		77	3 50
10 46	59		Horton		64	3 42
11 10	69		Nevada		64	3 36
11 20	71		Nassau		62	3 10
11 25	75		Milo		56	3 05
11 55	82		Sheldon		51	3 05
11 52	87		Irwin		46	2 55
12 03	94		Lamar		39	2 38

5 POINT NO 31 LIGHTFACE PER LB \$1 80 5 POINT NO 32 HEAVYFACE

10 10	0	Lv.	KANSAS CITY	Ar	760	5 45
10 17	1		Grand Avenue		759	5 38
10 30	6		Kansas City Junc		754	5 25
10 38	8		Centropolis		752	5 16
10 45	11		Leeds		749	5 09
11 00	18		Dodson		742	5 05
11 10	21		Red Bridge		739	4 47
11 19	25		Martin City		735	4 37
11 25	28		Newington		732	4 32
11 42	34		Stillwell		726	4 20
11 54	39		Bucyrus		721	4 02
11 59	43		Chiles		717	3 53
12 08	46		Wagstaff		714	3 47
12 25	54		Paola		706	3 27
12 42	61		Osawatimie		693	3 08
1 00	66		O'Brien		694	2 50

These Figures are cast on en set

SELF SPACING PIECE FRACTIONS

PRICE \$2 50 PER FONT EACH SIZE

These fonts are supplied with spaces, and can be used with ordinary as well as with Self Spacing Type

12 POINT OLD STYLE NO 28

1211¹/₃₂ 1234567890 1234567890 ~~1234567890~~ 1234567890 495¹/₁₆

11 POINT OLD STYLE NO 25

2417¹/₃₂ 1234567890 1234567890 ~~1234567890~~ 3⁷/₈ 4⁵/₈ 1234567890 1234567890 187¹/₁₆

10 POINT OLD STYLE NO 24

9019¹/₃₂ 1234567890 1234567890 ~~1234567890~~ 5¹⁰/₁₀ 1³/₈ 1234567890 1234567890 945¹/₁₆

9 POINT OLD STYLE NO 28

7313¹/₃₂ 1234567890 1234567890 ~~1234567890~~ 1⁵/₈ 2⁵/₈ 3⁶/₈ 4⁹/₈ 3¹⁰/₁₀ 1234567890 1234567890 257¹/₁₆

8 POINT OLD STYLE NO 22

2412¹/₃₅ 1234567890 1234567890 ~~1234567890~~ 1⁴/₄ 1²/₂ 2³/₈ 4⁵/₈ 5⁸/₈ 7⁸/₈ 8⁹/₈ 7²⁰/₂₀ 1234567890 1234567890 562¹/₁₆

6 POINT OLD STYLE NO 27

4211¹/₃₂ 1234567890 1234567890 ~~1234567890~~ 1³/₈ 2³/₈ 1⁴/₂ 1²/₂ 3⁴/₈ 1⁸/₈ 3⁸/₈ 5⁸/₈ 7⁸/₈ 3⁶/₆ 5⁶/₆ 1234567890 1234567890 331¹/₁₆6 POINT ROMAN NO 20¹/₂202³/₈ 1234567890 1234567890 ~~1234567890~~ 1³/₈ 2³/₈ 1⁴/₂ 1²/₂ 3⁴/₈ 5⁶/₈ 7⁸/₈ 9⁸/₈ 10¹⁰/₁₀ 10¹²/₁₂ 1¹⁶/₂ 1234567890 1234567890 401¹/₁₆7 POINT ROMAN NO 23¹/₂3911¹/₁₆ 1234567890 1234567890 ~~1234567890~~ 1⁶/₈ 2⁶/₈ 3⁶/₈ 5⁶/₈ 7⁸/₈ 8⁹/₈ 9¹⁰/₁₀ 10¹¹/₁₁ 15¹⁶/₁₆ 1234567890 1234567890 572¹/₁₆8 POINT ROMAN NO 18¹/₂1911¹/₃₂ 1234567890 1234567890 ~~1234567890~~ 1⁸/₈ 3⁸/₈ 5⁶/₆ 6⁶/₆ 7¹⁰/₁₀ 9²⁰/₂₀ 10²⁰/₂₀ 1234567890 1234567890 845¹/₁₆9 POINT ROMAN NO 32¹/₂3212¹/₃₂ 1234567890 1234567890 ~~1234567890~~ 2⁸/₈ 4⁶/₆ 5⁶/₆ 7⁸/₈ 9¹⁰/₁₀ 1234567890 1234567890 239¹/₁₆10 POINT ROMAN NO 17¹/₂7213¹/₃₂ 1234567890 1234567890 ~~1234567890~~ 2⁰/₀ 4⁵/₅ 1234567890 1234567890 367¹/₁₆11 POINT ROMAN NO 21¹/₂4511¹/₃₂ 1234567890 1234567890 ~~1234567890~~ 1234567890 1234567890 218¹/₁₆12 POINT ROMAN NO 31¹/₂6020¹/₃₂ 1234567890 1234567890 ~~1234567890~~ 1234567890 1234567890 149¹/₁₆

SUPERIOR AND INFERIOR LETTERS AND FIGURES

4-15

Prices quoted are per pound of either

12 POINT NO 150 PER LB. \$1 16
 abcdefghijklmnopqrst
 1234567890 abcdefghijklmnopqrst
 1234567890 1234567890

11 POINT NO 150 PER LB. \$1 22
 abcdefghijklmnopqrs abcdefghijklmnopqrs
 1234567890 1234567890

10 POINT NO 150 PER LB. \$1 30
 abcdefghijklmnopqrstuv abcdefghijklmnopqrstuv
 1234567890 1234567890

9 POINT NO 150 PER LB. \$1 44
 abcdefghijklmnopqrstuv abcdefghijklmnopqrstuv
 1234567890 1234567890

8 POINT NO 150 PER LB. \$1 60
 abcdefghijklmnopqrstuvw abcdefghijklmnopqrstuvw
 1234567890 1234567890

7 POINT NO 150 PER LB. \$1 80
 abcdefghijklmnopqrstvwxyz abcdefghijklmnopqrstvwxyz
 1234567890 1234567890

6 POINT NO 150 PER LB. \$2 00
 abcdefghijklmnopqrstvwxyz abcdefghijklmnopqrstvwxyz
 1234567890 1234567890

5 1/2 POINT NO 40 PER LB. \$2 40
 abcdefghijklmnopqrstvwxyz abcdefghijklmnopqrstvwxyz
 1234567890 1234567890

DIAGONAL FRACTION MARKS

PRICE PER FONT, CONTAINING THREE SIZES \$0 75
 12 POINT 9 POINT 6 POINT
 // // // // // // // // // //

EXAMPLES

8 2/5 5 3/8 2 7/8 24/100
 3 4/5 2 3/8 1 1/2 3 1/4 15/100
 5 1/2 8 7/8 4 2/3 5 3/4 6 3/4 150/1000

For Jobbing Fractions, see pages 503 and 509

PIECE FRACTIONS

4-12

12 POINT NO 120 PER LB. \$2 00
 1 2 3 4 5 6 7 8 9 0
 1 2 3 4 5 6 7 8 9 0
 2 3 5 1 3 9 3 3
 5 1 6 3 6 6 8 1 0 0 1 0 0

11 POINT NO 120 PER LB. \$2 40
 1 2 3 4 5 6 7 8 9 0
 1 2 3 4 5 6 7 8 9 0
 2 3 5 4 3 5 7 6 8
 3 7 9 2 5 8 6 2 3 4 2 7 5

10 POINT NO 120 PER LB. \$2 80
 1 2 3 4 5 6 7 8 9 0
 1 2 3 4 5 6 7 8 9 0
 2 3 4 9 0 1 0 1 6 0 2 4 5
 5 2 0 6 8 9 0 1 0 1 6 0 2 0 0

9 POINT NO 120 PER LB. \$3 20
 1 2 3 4 5 6 7 8 9 0 1 2 3 4 5 6 7 8 9 0
 2 4 2 7 3 6 8 8 1 6 0 3 8 0 1 0 0 0

8 POINT NO 120 PER LB. \$3 60
 1 2 3 4 5 6 7 8 9 0 1 2 3 4 5 6 7 8 9 0
 4 2 1 7 4 5 8 8 1 5 0 4 9 7 1 5 0 0

7 POINT NO 40 PER FONT \$5 00
 1 2 3 4 5 6 7 8 9 0 1 2 3 4 5 6 7 8 9 0
 1 2 3 4 2 8 4 5 8 2 2 8 2 8 2 8 4 2 8 5

6 POINT NO 120 PER LB. \$5 00
 1 2 3 4 5 6 7 8 9 0 1 2 3 4 5 6 7 8 9 0
 4 2 3 4 5 6 7 8 9 0 1 0 1 6 0 1 6 0 1 6 0

SPECIAL FRACTIONS

4-15

8 POINT NO 1528 1 LB. FONT \$0 90
 1 4 1 2 3 4 1 3 2 3 1 8 3 8 5 8 7 8

7 POINT NO 1528 1 LB. FONT \$1 00
 1 4 1 2 3 4 1 3 2 3 1 3 3 8 5 8 7 8

6 POINT NO 1528 1 LB. FONT \$1 16
 1 4 1 2 3 4 1 3 2 3 1 3 3 8 5 8 7 8

5 1/2 POINT NO 1528 1 LB. FONT \$1 44
 1 4 1 2 3 4 1 3 2 3 1 4 3 8 5 8 7 8

6 POINT NO 154 1 LB. FONT \$1 16
 1 4 1 2 4 4 1 3 2 3 1 8 3 8 5 8 7 8

5 1/2 POINT NO 154 1 LB. FONT \$1 44
 1 4 1 2 3 4 1 3 2 3 1 8 3 8 5 8 7 8

5 1/2 POINT NO 40 ONE-AND-A-HALF EM FRACTIONS
 1/16 3/16 5/16 7/16 9/16 11/16 13/16 15/16

ILLUSTRATIONS AND DEFINITIONS OF SIGNS

MATHEMATICAL

- + plus
- minus
- × into, with
- ÷ divided by
- = equality
- ± plus or minus
- square
- ▭ rectangle
- △ triangle
- circle
- ∠ angle
- ⊥ right angle
- ⊃ or > greater than
- ⊂ or < less than
- ⊥ perpendicular
- ∓ difference
- ∫ integration
- ≈ equivalency
- ∴ proportion
- ≐ geometrical proportion
- : difference, excess

MATHEMATICAL

- (Continued)*
- ∴ therefore
 - ∵ because
 - √ radical
 - ° degrees
 - ' minutes
 - " seconds

COMMERCIAL

- @ at, to
- ℥ per, each
- ℔ pound
- % percentum
- / shilling
- ¢ cent
- ℥ account

MEDICAL

- ℞ recipe, take
- ℥ ounce
- ℥ drachm
- ℥ scruple

ECCLESIASTICAL

- ∇ versicle
- ℞ response
- ✝ or † sign of the cross

ASTRONOMICAL

- ♈ Aries
- ♉ Taurus
- ♊ Gemini
- ♋ Cancer
- ♌ Leo
- ♍ Virgo
- ♎ Scorpio
- ♏ Sagittarius
- ♐ Capricornus
- ♑ Aquarius
- ♒ Pisces
- ☉ or ☌ Sun
- ☿ Mercury
- ♀ Venus
- ♁ or ☌ Earth

ASTRONOMICAL

- (Continued)*
- ♄ Mars
 - ♃ Jupiter
 - ♅ Saturn
 - ♁ or ♅ Uranus
 - ♆ Neptune
 - ♁ New Moon
 - ♁ First Quarter
 - ☾ Full Moon
 - ♁ Last Quarter
 - ♁ Conjunction
 - ♁ Opposition
 - ♁ Trine
 - ♁ Quartile
 - ♁ Sextile
 - ♁ Dragon's Head
 - ♁ Dragon's Tail
 - ♁ Ceres
 - ♁ Pallas
 - ♁ Juno
 - ♁ Vesta

MEDICAL SIGNS

12 POINT	PER FONT \$1 00
3 3 ℞ ℞	
11 POINT	PER FONT \$1 00
3 3 ℞ ℞	
10 POINT	PER FONT \$1 00
3 3 ℞ ℞	
9 POINT	PER FONT \$1 00
3 3 ℞ ℞	
8 POINT	PER FONT \$1 00
3 3 ℞ ℞	
7 POINT	PER FONT \$1 00
3 3 ℞ ℞	
6 POINT	PER FONT \$1 00
3 3 ℞ ℞	

COMMERCIAL SIGNS

12 POINT	PER LB. \$1 16
℥ @ ℔ % ‰ ℥	
11 POINT	PER LB. \$1 22
℥ @ ℔ % ‰ ℥	
10 POINT	PER LB. \$1 30
℥ @ ℔ % ‰ ℥	
9 POINT	PER LB. \$1 44
℥ @ ℔ % ‰ ℥	
8 POINT	PER LB. \$1 60
℥ @ ℔ % ‰ ℥	
7 POINT	PER LB. \$1 80
℥ @ ℔ % ‰ ℥	
6 POINT	PER LB. \$2 00
℥ @ ℔ % ‰ ℥	
5 1/4 POINT	PER LB. \$2 40
℥ @ ℔ % ‰ ℥	

ARITHMETICAL SIGNS

12 POINT	PER FONT \$1 16
+ - × ÷ =	
11 POINT	PER FONT \$1 22
+ - × ÷ =	
10 POINT	PER FONT \$1 30
+ - × ÷ =	
9 POINT	PER FONT \$1 44
+ - × ÷ =	
8 POINT	PER FONT \$1 60
+ - × ÷ =	
7 POINT	PER FONT \$1 80
+ - × ÷ =	
6 POINT	PER FONT \$2 00
+ - × ÷ =	
5 1/4 POINT	PER FONT \$2 40
+ - × ÷ =	

ALGEBRAIC SIGNS

12 POINT	PER FONT \$1 16
51 52 53 54 55 56 57	
+ - × ÷ = ±	
59 60 61 62 63 64 65	
□ △ < √ ∫ ∴	
66 67	

11 POINT	PER FONT \$1 22
51 52 53 54 55 56 57	
+ - × ÷ = ±	
59 60 61 62 63 64 65	
□ △ < √ ∫ ∴	
66 67	

10 POINT	PER FONT \$1 30
51 52 53 54 55 56 57	
+ - × ÷ = ±	
59 60 61 62 63 64 65	
□ △ < √ ∫ ∴	
66 67	

9 POINT	PER FONT \$1 44	8 POINT	PER FONT \$1 60	7 POINT	PER FONT \$1 80
51 52 53 54 55 56 57 59	+ - X ÷ = ÷ ± □	51 52 53 54 55 56 57 59 60	+ - X ÷ = ÷ ± □ △	51 52 53 54 55 56 57 58 59 60	+ - X ÷ = ÷ ± □ △
60 61 62 63 64 65 66 67	△ < √ ∇ ∴ ∷ ∠ ∽	61 62 63 64 65 66 67	< √ ∇ ∴ ∷ ∠ ∽	61 62 63 64 65 66	< √ ∇ ∴ ∷ ∠
6 POINT	PER FONT \$2 00	5 1/2 POINT	PER FONT \$2 40		
51 52 53 54 55 56 57 58 59 60 61 62 63 64 65 66	+ - X ÷ = ÷ ± □ □ △ < √ ∇ ∴ ∷ ∠	51 52 53 54 55 56 57 58 59 60 61 62 63 64 65 66	+ - X ÷ = ÷ ± □ □ △ < √ ∇ ∴ ∷ ∠		

ASTRONOMICAL SIGNS

24 POINT **8 CENTS EACH**

20 POINT **8 CENTS EACH**

16 POINT **6 CENTS EACH**

12 POINT NO 3 **PER FONT \$3 00**

12 POINT NO 2 **PER FONT \$3 00**

11 POINT NO 2 **PER FONT \$3 00**

10 POINT NO 2 **PER FONT \$3 00**

9 POINT NO 2 **PER FONT \$2 25**

8 POINT NO 2 **PER FONT \$2 00**

14 POINT NO 1 **PER FONT \$5 40**

12 POINT NO 1 **PER FONT \$4 50**

11 POINT NO 1 **PER FONT \$4 50**

10 POINT NO 1 **PER FONT \$4 75**

ASTRONOMICAL SIGNS—Continued

9 POINT No 1 PER FONT \$5 00

1	2	3	4	5	6	7	8	9	10	11	12		
♈	♉	♊	♋	♌	♍	♎	♏	♐	♑	♒	♓		
13	14	15	16	17	18	19	20	21	22	23	24	25	26
♄	♅	♆	♇	♈	♉	♊	♋	♌	♍	♎	♏	♐	♑
27	28	29	30	31	32	33	34	35	36	37	38		
♒	♓	♈	♉	♊	♋	♌	♍	♎	♏	♐	♑		

7 POINT No 1 PER FONT \$2 75

1	2	3	4	5	6	7	8	9	10	11	12	13	14	
♈	♉	♊	♋	♌	♍	♎	♏	♐	♑	♒	♓	♄	♅	
15	16	17	18	19	20	21	22	23	24	25	26	27	28	29
♆	♇	♈	♉	♊	♋	♌	♍	♎	♏	♐	♑	♒	♓	♄
30	31	32	33	34	35	36	37	38						
♈	♉	♊	♋	♌	♍	♎	♏	♐						

8 POINT No 1 PER FONT \$5 00

1	2	3	4	5	6	7	8	9	10	11	12		
♈	♉	♊	♋	♌	♍	♎	♏	♐	♑	♒	♓		
13	14	15	16	17	18	19	20	21	22	23	24	25	26
♄	♅	♆	♇	♈	♉	♊	♋	♌	♍	♎	♏	♐	♑
27	28	29	30	31	32	33	34	35	36	37	38		
♒	♓	♈	♉	♊	♋	♌	♍	♎	♏	♐	♑		

6 POINT No 1 PER FONT \$2 25

1	2	3	4	5	6	7	8	9	10	11	12	13	14	15	16	
♈	♉	♊	♋	♌	♍	♎	♏	♐	♑	♒	♓	♄	♅	♆	♇	
17	18	19	20	21	22	23	24	25	26	27	28	29	30	31	32	33
♆	♇	♈	♉	♊	♋	♌	♍	♎	♏	♐	♑	♒	♓	♄	♅	♆
34	35	36	37	38												
♈	♉	♊	♋	♌												

PIECE ROOT SIGNS

For making Root Signs of any power. Prices quoted are per pound

16 POINT	✓ /	\$1 06	20 POINT	✓ /	\$0 94
8 POINT	✓ /	\$1 60	10 POINT	✓ /	\$1 30

MISCELLANEOUS SIGNS

Cast to order. In ordering Signs, state size and No.

12 POINT	908	909	910	911	912	913	914	915	PER LB. \$1 16		
	'	o	#	Y	+	+	+	+			
11 POINT	901	902	903	904	905	906	907	PER LB. \$1 22			
	'	o	#	Y	+	+	+				
10 POINT	893	894	895	896	897	898	899	900	PER LB. \$1 30		
	'	o	#	*	Y	+	+	+			
9 POINT	883	884	885	886	887	888	889	890	891	892	PER LB. \$1 44
	'	o	#	*	Y	+	+	+	+	+	
8 POINT	873	874	875	876	877	878	879	880	881	882	PER LB. \$1 60
	'	o	#	*	Y	+	+	+	+	+	
7 POINT	865	866	867	868	869	870	871	872	PER LB. \$1 80		
	'	o	Y	+	+	+	+	"			
6 POINT	857	858	859	860	861	862	863	864	PER LB. \$2 00		
	M	Y	+	+	+	+	+	+			
5½ POINT	854	855	856	PER LB. \$2 40							
	M	o	+								

12 POINT	839	840	841	842	843	844	845	846	922	923	PER LB. \$1 16		
	+	X	%	%	5	D	3	#	%				
10 POINT	739	740	741	742	743	744	745	746	747	748	749	PER LB. \$1 30	
	—	=	+	×	÷	±	±	□	□	△	△		
	750	751	752	753	754	755	756	757	758	759	760		
	<	~	√		≅	∠	∠	∠	∠	∠	::		
	761	762	763	764	765	766	766½	767	768	769	770	771	
	—	:	o	□	o	'	"	%	%	¢	@		
	772	773	774	775	776	777	778	779	780	781	782		
	℘	ℙ	ℚ	ℓ	ℓ	ℓ	ℓ	ℓ	ℓ	ℓ	ℓ		
	783	784	785	786	787	788	789	790	791	792			
	o	o	o	o	o	o	o	o	o	o			
	793	794	795	796	797	798	799	800	801	802	803		
	/	o	≅	♀	∨	∧	∩	∩	∩	∩	∩		
	804	805	806	807	808	809	810	811	812	813	814		
	∏	∏	∏	∏	∏	∏	∏	∏	∏	∏	∏		
	815	816	817	818	819	820	821	822	823	824	825	826	
	♀	♂	♂	♂	♂	♂	♂	♂	♂	♂	♂	♂	
	827	828	829	830	831	832	833	834	835	836	837	838	
	△	□	□	□	□	□	□	□	□	□	□	□	

8 POINT PER LB. \$1 60

845 846 847 848 849 850 851 852 853 854 855 856
 - = + X ÷ # ± □ □ △ < >

857 858 859 860 861 862 863 864 865 866 867 868
 ~ √ L Z ≅ ∟ ∩ ∴ ∷ ∴ ∴ ∴

869 870 871 872 873 874 875 876 877 878 879 880
 ° ° ° ° ° ° ° ° ° ° ° °

881 882 883 884 885 886 887 888 889 890 891 892
 ♂ ♀ † ‡ § ¶ † ‡ § ¶ † ‡ § ¶

893 894 895 896 897 898 899 900 901 902 903 904
 ♂ ♀ † ‡ § ¶ † ‡ § ¶ † ‡ § ¶

905 906 907 908 909 910 911 912 913 914 915 916
 ♂ ♀ † ‡ § ¶ † ‡ § ¶ † ‡ § ¶

917 918 919 920 921 922 923 924 925 926 927 928
 ♂ ♀ † ‡ § ¶ † ‡ § ¶ † ‡ § ¶

929 930 931 932 933 934 935 936 937 938
 □ ♂ ⊕ ⊗ ⊙ ⊚ ⊛ ⊜ ⊝ ⊞ ⊟ ⊠ ⊡

6 POINT PER LB. \$2 00

550 551 552 553 554 555 556 557 558 559 560 561 562
 - = + X + # ± □ □ △ < > ~

563 564 565 566 567 568 569 570 571 572 573 574 575
 √ ∥ ≅ ∟ L V ∟ ∩ ∴ ∷ ∴ ∴ ∴

576 577 578 579 580 581 582 583 584 585 586 587 588
 ° √ + ° ° ° ° ° ° ° ° ° ° ° °

589 590 591 592 593 594 595 596 597 598 599 600 601
 ⊙ ⊚ ⊛ ⊜ ⊝ ⊞ ⊟ ⊠ ⊡ ⊢ ⊣ ⊤ ⊥ ⊦ ⊧ ⊨ ⊩ ⊪ ⊫ ⊬ ⊭ ⊮ ⊯ ⊰ ⊱ ⊲ ⊳ ⊴ ⊵ ⊶ ⊷ ⊸ ⊹ ⊺ ⊻ ⊼ ⊽ ⊾ ⊿ ⊿ ⊿

602 603 604 605 606 607 608 609 610 611 612 613 614
 ♂ ♀ † ‡ § ¶ † ‡ § ¶ † ‡ § ¶ † ‡ § ¶

615 616 617 618 619 620 621 622 623 624 625 626 627
 † ‡ § ¶ † ‡ § ¶ † ‡ § ¶ † ‡ § ¶ † ‡ § ¶ † ‡ § ¶

628 629 630 631 632 633 634 635 636 637 638 639 640
 ♂ ♀ † ‡ § ¶ † ‡ § ¶ † ‡ § ¶ † ‡ § ¶ † ‡ § ¶

641 642 643 644
 ♂ ♀ † ‡

924. 25 cts.



925. 25 cts.



847. 10 cts.



926. 20 cts.



848. 10 cts.



927. 20 cts.

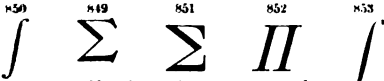

Nos. 840 to 853, 15 cents each

Miscellaneous Signs are cast to order only

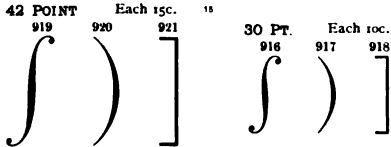

CANCELLED FIGURES

11 POINT NO 40 PER LB. 70 OTS
 1 2 3 4 5 6 7 8 9 0

10 POINT NO 150 PER LB. 74 OTS.
 1 2 3 4 5 6 7 8 9 0

9 POINT NO 40 PER LB. 80 OTS.
 1 2 3 4 5 6 7 8 9 0

8 POINT NO 150 PER LB. 90 OTS.
 1 2 3 4 5 6 7 8 9 0

SPECIAL FIGURES

8 POINT TWO-THIRD FIGURES PER LB. \$0 90
 1 2 3 4 5 6 7 8 9 0 \$

7 POINT TWO-THIRD FIGURES PER LB \$1 00
 1 2 3 4 5 6 7 8 9 0 \$

6 POINT TWO-THIRD FIGURES PER LB \$1 16
 1 2 3 4 5 6 7 8 9 0 \$

5 1/2 POINT TWO-THIRD FIGURES PER LB. \$1 44
 1 2 3 4 5 6 7 8 9 0 \$

5 POINT TWO-THIRD FIGURES PER LB. \$1 80
 1 2 3 4 5 6 7 8 9 0 \$

6 POINT EN FIGURES PER LB \$1 16
 1 2 3 4 5 6 7 8 9 0

5 1/2 POINT EN FIGURES PER LB. \$1 44
 1 2 3 4 5 6 7 8 9 0

SPECIAL LOGOTYPES

Special Logotypes will be engraved and cast to order. The following are a few examples of those we have matrices for and can supply to order:

8 POINT
 A.M. P.M. A. P. M. A. L.V. " \ Fed. *

6 POINT
 am pm A.M. P.M. A.M. P.M.
 Ar. Lv. TEX " A.M. P.M.

ST. LOUIS SE AM PM

5 1/2 POINT
 1 Mile. AM PM 4 5 Fig.

COPPER ALLOY FINE-DOT LEADERS

These are used as a substitute for Dotted Brass Rule, and save the time spent in justification. Made on 6, 7, 8, 9, 10, 11 and 12 point bodies. When ordering, state the type (if our make) they are required to line with, or send sample cap "H" or lower-case "m." The following examples shows Fine-Dot Leaders lining with 8 Point Law Italic No. 120 and 10 Point Law Italic No. 122:

8 POINT FINE-DOT LEADERS

In combination with 8 Point Law Italic No. 120

*A Court of.....will be
held in the town of.....
on May 10th.....
.....and the following
persons will be tried.....
.....by order of
.....Judge*

6 Point, put up in 5-lb. founts . . . per lb., \$0.64
7 Point, put up in 5-lb. founts . . . per lb., 0.56
8 Point, put up in 5-lb. founts . . . per lb., 0.52
12 Point, put up in 5-lb. founts . . . per lb., \$0.42

10 POINT FINE-DOT LEADERS

In combination with 10 Point Law Italic No. 122

*You.....are hereby
commanded to take.....
and deliver him to.....by
.....at noontime,
without fail.....
.....in said township
County of.....*

9 Point, put up in 5-lb. founts . . . per lb., \$0.48
10 Point, put up in 5-lb. founts . . . per lb., 0.46
11 Point, put up in 5-lb. founts . . . per lb., 0.44
12 Point, put up in 5-lb. founts . . . per lb., \$0.42

LEADERS FOR BODY TYPE

These are put up in 5-lb. founts, and are not included in founts of body type. It is always necessary to state the type the leaders are required to line with, or to send a cap "H" and lower case "m" of the type. We make the following styles, the prices of which are the same as for Fine-Dot Leaders shown above:

- HYPHEN (two strokes to the em)**.....
For 6, 7, 8, 10, 11 and 12 point bodies.
- REGULAR (two dots to the em)**.....
For 5, 5½, 6, 7, 8, 9, 10, 11 and 12 point bodies.
- OPEN (one dot to the em)**
For 6, 7, 8, 9, 10, 11 and 12 point bodies.

NEW METAL BRACES

6 POINT PER FOUNT (two of each length) \$1 00
PER DOZEN OF ANY ONE SIZE 50 CENTS

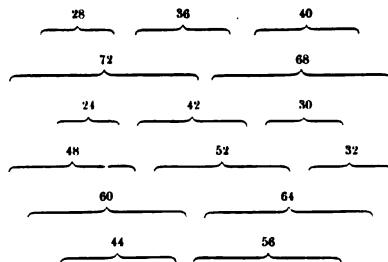

The No. also indicates the length of each Brace in points

6 POINT BRACES AND DASHES No 2

PRICE PER FOUNT \$1 25

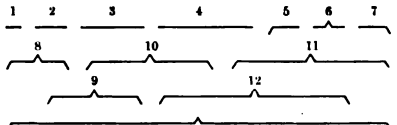

Nos. 8 to 12 are complete; Nos. 1 to 7 are for piecing.

6 POINT METAL BRACES

PRICE PER FOUNT \$1 00



ACCENTED LETTERS

We make a vast number of accented letters for both body and job type for use in the Spanish, French, German, Swedish, Norwegian, Danish, Italian, Portuguese, Polish and Bohemian languages, and can furnish complete outfits for printing in any of those languages. We print below assortments of accents used in various languages for the information of our customers, who will be informed upon application as to which of these accents can be supplied for any size or series of type. Accents not in common use in this country will be cut to order at a charge of \$2.00 and upwards per matrix, such matrices becoming the property of the customer. Accents for which we have matrices will be furnished at the same rate as charged for the font for which they are ordered.

The following lower case accented letters of Roman and Italic are furnished with the body type for which they are made, and a number of these accented letters can also be furnished in capitals and small capitals.

Acute . . . á é í ó ú | Circumflex â ê î ô û | Long . . . ā ē ī ō ū | Spanish (Nya) . . . ñ
 Grave . . . à è ì ò ù | Diaeresis . ä ë ï ö ü | Short . . . ă ę ı ő ů | French (Cedilla) . . . ç

ACCENTED LETTERS USED IN VARIOUS MODERN LANGUAGES

BOHEMIAN
 Ā Č Ď Ě Ě Í Ň Ó Ř Š Ť Ů Ú Ý Ž
 á č ď é ě í ň ó ř š ť ú ú ý ž

DANISH AND NORWEGIAN
 Ø ø

FRENCH
 É À È Ù Á Ê Î Ô Û Ç
 é à è ù â ê î ô ù ç ï ë ü

GERMAN
 Ä Ö Ü ä ö ü

HUNGARIAN
 Á É Í Ó Ú Ö Ű Ő Ű
 á é í ó ú ö ü ő ű

ITALIAN
 À È Ì Ò Ù à è ì ò ù



POLISH
 Ą ą Ć ć Ę ę Ł ł Ó ó Ś ś Ź ź



PORTUGUESE
 Á É Í Ó Ú Ñ Ç Û Ä Ö
 á é í ó ú ñ ç ü ä ö

SPANISH
 Á É Í Ó Ú Ñ Û
 á é í ó ú ñ ü

SWEDISH
 Å Ä Ö å ä ö

PIECE ACCENTS

12 POINT NO 6 ' \$1 50

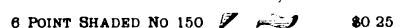
 12 POINT ' \$1 50

 9 POINT ' \$1 10

6 POINT NO 150 \$0 50

 4 POINT NO 150 \$0 40

 3 POINT NO 150 \$0 30

 6 POINT SHADED NO 150 \$0 25

SPECIMENS OF PIECE ACCENTS ON TYPE CAST WITHOUT ACCENTS

Á É Í Ó Ú À È Ì Ò Ù Ñ Â Ö
 Á É Í Ó Ú Á È Ì Ò Ù À È Ä Ö Û Ä Ñ Ò

DESCRIPTION OF SELF SPACING TYPE

SELF SPACING TYPE IS MADE UNDER PATENTS ISSUED DECEMBER 16, 1883

The common widths of book pages, miscellaneous jobs and newspaper columns are some number of Pica ems, therefore the Pica em is taken as the basis for Self Spacing type. The thinnest space in all fonts is some exact fraction of a Pica, and this fraction of Pica is called the unit of measure. All characters, spaces and quads in the font are made some exact multiple of this unit in width, so that the sizes of all faces will work perfectly together in the regular labor-saving measures. This unit of measure may be one-sixth, one-seventh, one-eighth, one-ninth, etc., of a Pica em, as may be desired, to produce condensed, medium or extended faces. The following table gives the sizes of bodies, units of measure, and lengths of alphabets. In the first column will be found the various sizes of bodies; in the second, the number of units contained in one em Pica, and in the third the measurements of a lower case alphabet in the ems of each particular body:

BODY	Number Units to Pica em	Length of Alphabet
5½ Point (Agate).....	12	167½
6 Point (Nonpareil)...	12	15½
6 Point (Nonpareil)...	11	17
7 Point (Minion).....	11	14½
7 Point (Minion).....	10	16
8 Point (Brevier).....	11	12¾
8 Point (Brevier).....	10	14½
8 Point (Brevier).....	9	15½
9 Point (Bourgeois)...	10	12¾
9 Point (Bourgeois)...	9	13¾
10 Point (Lg. Primer)...	9	12¾
10 Point (Lg. Primer)...	8	14
11 Point (Small Pica)...	8	12¾
11 Point (Small Pica)...	7	14½
12 Point (Pica).....	7	13¼

In the foregoing table will be found a Nonpareil with one-twelfth of Pica as the unit of measure. This is one-sixth of the body of Nonpareil, or the six-to-em space, and preserves in this particular font the old three-to-em space and the old en and em

quads. The same is true of the Brevier on one-ninth, Bourgeois on one-eighth, and Pica on one-sixth of Pica.

In a complete font of the old kind of body type there are about 190 widths of bodies. Appended is a table showing the different widths of bodies of Self Spacing. It will be readily seen that there are but nine widths of bodies all told, and that the four-unit width predominates largely over any other, there being fifty-nine characters of this width. We omit the Italic characters from the table, as they go on the same widths of bodies and are interchangeable with the Roman:

1 unit—Space.....	1
2 units—Space, f i j l , ; ; - ' ! ' 16	16
3 units—Quad, c e r s t z s z I J ?) [* † ‡ § ¶ - °.....	22
4 units—Quad, a b d g h k n o p q u v x y f i f f \$ £ 1 2 3 4 5 6 7 8 9 O A B C D E F G L N O P Q R T U V X Y & S Z . -) { } / \ 59	59
5 units—æ A B C D E F G L N O P Q R T U V Y H K M.....	21
6 units—Quad, m w œ w æ œ f i f i H K X & n ð @ - ... ¼ ½ ¾ ⅓ ⅔ ⅕ ⅖ ⅗ ⅘.....	27
7 units—W M.....	2
8 units—E Æ.....	2
12 units—Quad, — œ œ œ œ œ.....	9
9 sizes. Roman characters.....	155
Italic characters.....	77
Total.....	232

Any compositor can see that no combination of units can be made that will not come within a certain number of exact units of filling a line. If a line of matter lacks, it must lack one or more exact units.

Self Spacing type sets line for line with the ordinary Roman, where the lengths of the alphabets are the same.

Repeated experiments with the new type have shown that the average compositor gains about twenty-five per cent. in speed, with no trouble in justification whatever.

In the matter of the correction of proofs the gain is enormous. Say there is an "a" for "e"; as "a" is four units wide and "e" three, "e" and one unit space justify the line perfectly. Even this measure of trouble is avoided in many instances. As twenty-eight of the most common lower case characters are of the same width, they can be substituted for one another without the change of a space.

This type is of greater durability, as it is always on its feet and is therefore not worn by "pounding."

In tabular work there is a great gain in speed and neatness. By the addition of a new character, viz: "|", it is easy to set perpendicular lines of any length, line upon line.

It may be repeated that the compositor has nothing to learn in Self Spacing type. There is but a single direction to be given—to set that which looks like the em quad (six unit quad) with the nick out.

Whoever will study the principle on which Self Spacing type is based, will readily admit that it is bound to secure easy and perfect justification, greatly increased speed and consequent enormous saving, simplicity and rapidity of proof correction, and increased accuracy and ease in the setting of tables. All these points are beyond question, as certainly as the proposition that two and two make four is not open to argument. No rational person can doubt them.

The following piece of composition was done in a 12½-em measure stick, and set line upon line in the ordinary manner of straight reading matter, the lower part being leaded to show the method of setting:

No. 1	No. 2	No. 3	No. 4.	No. 5	No. 6	No. 7
i and	i HX	i DLE	s atards	i MP	i dim	' D N
s mit	i NK	s MIT	is thmuj	s NK	s mit	s MIT
b rot	S LY	B AIT	ne ver fr	d LY	b rot	S AIT
s tly	E LS	M ine	Th uraci	s LS	M tly	E RK
m an	H IE	L ED	line for	m IE	L nd	H AD
su it	SI SI	SE ES	nine five	so IS	SE at	SI LS
no ts	NI X	PU SS	in cre asi	mi X	PA st	BI ts
No is	SA T	No is	comp oz	ME T	MA D	SU it
gla d	FO Z	FLI T	Repea t	gla S	BIN S	FO x
mit c	OH I	SEA S	second r	sn I	SEA I	HO e
still i	\$34	NOT i	beat th	this i	NOT i	234 i

To further explain and illustrate the ease with which table work is done with Self Spacing type, we show above an example of miscellaneous justifications, which is absolutely impossible to accomplish with the old kind of type. In column No. 1 the first line begins with the lower case "i", two units wide, which is followed by the upright dash "|", two units, and the characters "a", four units, "n", four units, "d", four units, comprising sixteen units to accurately fill the column. The second line begins with the letter "s," three units wide, which throws the space rule one unit further to the right than in the preceding line. In each succeeding line lower case characters are used to the total width of sixteen units, and such characters are chosen for the first part thereof as will admit of advancing the space rule to the right exactly one unit in each succeeding line.

In the other columns the same plan is followed, the only change being the substitution of caps, small caps, figures, etc., for the lower case characters, all columns coming perfectly justified inside the perpendicular lines.

SELF SPACING SIGNS

These signs are furnished for every face of Self Spacing type, and may be used with point system bodies. When ordering state size of body and (if Self Spacing) number of face wanted.

PRICE \$1 00 PER FONT EACH SIZE

×	+	-	=	±	:	::	÷	≡	<	>	△	□	√	∛	℞	℔	℥	℥	%	‰	ℓ	⊗	⋈	⋈	+
×	+	-	=	±	:	::	÷	≡	<	>	△	□	√	∛	℞	℔	℥	℥	%	‰	ℓ	⊗	⋈	⋈	+
×	+	-	=	±	:	::	÷	≡	<	>	△	□	√	∛	℞	℔	℥	℥	%	‰	ℓ	⊗	⋈	⋈	+
×	+	-	=	±	:	::	÷	≡	<	>	△	□	√	∛	℞	℔	℥	℥	%	‰	ℓ	⊗	⋈	⋈	+
×	+	-	=	±	:	::	÷	≡	<	>	△	□	√	∛	℞	℔	℥	℥	%	‰	ℓ	⊗	⋈	⋈	+
×	+	-	=	±	:	::	÷	≡	<	>	△	□	√	∛	℞	℔	℥	℥	%	‰	ℓ	⊗	⋈	⋈	+

SELF SPACING MODERN ROMAN—NEWSPAPER STYLE

6 POINT NO 20½

Unit of measure, 12 to Pica

WHEN, in the course of human events, it becomes necessary for one people to dissolve the political bands which have connected them with another, and to assume, among the powers of the earth, the separate and equal station to which the laws of nature and of nature's God entitle them, a due respect to the opinion of mankind requires that they should declare the causes which impel them to the separation. We hold these truths to be self-evident, that all men are created equal; that they are endowed by their Creator with certain unalienable rights; that among these, are life, liberty, and the pursuit of happiness. That, to secure these rights, governments are instituted among men, deriving their just powers from the consent of the governed; that, whenever any government becomes destructive of these ends, it is the right of the people to alter or to abolish it, and to institute a new government, laying its foundation on such principles, and organizing its powers in such form, as to them shall seem most likely to effect their safety and happiness. Prudence, indeed, will dictate that governments long established, should not be changed for light and transient causes; and, accordingly, all experience hath shown, that mankind are more disposed to suffer, while evils are sufferable, than they are to

Lower case a to z, 15½ ems

7 POINT NO 23½

Unit of measure, 11 to Pica

WHEN, in the course of human events, it becomes necessary for one people to dissolve the political bands which have connected them with another, and to assume, among the powers of the earth, the separate and equal station to which the laws of nature and of nature's God entitle them, a decent respect to the opinion of mankind requires that they should declare the causes which impel them to the separation. We hold these truths to be self-evident, that all men are created equal; that they are endowed by their Creator with certain unalienable rights; that among these, are life, liberty, and the pursuit of happiness. That, to secure these rights, governments are instituted among men, deriving their just powers from the consent of the governed; that, whenever any form of government becomes destructive of these ends, it is the right of the people to alter or to abolish it, and to institute a new government, laying its foundation on such principles, and organizing its powers in such form, as to them shall seem

Lower case a to z, 14½ ems

For other sizes of this series, see pages 85 to 87

8 POINT NO 18½

Unit of measure, 10 to Pica

WHEN, in the course of human events, it becomes necessary for one people to dissolve the political bands which have connected them with another, and to assume, among the powers of the earth, the separate and equal station to which the laws of nature and of nature's God entitle them, a decent respect to the opinions of mankind requires that they should declare the causes which impel them to the separation. We hold these truths to be self-evident, that all men are created equal; that they are endowed by their Creator with certain unalienable rights; that among these, are life, liberty, and the pursuit of happiness. That, to secure these rights, governments are instituted among men, deriving their just powers from the consent of the governed; that, whenever any form of government becomes destructive of these ends, it is the right of the people to alter or to abolish it, and to institute a new government, laying its foundation on

Lower case a to z, 14¼ ems

9 POINT NO 32½

Unit of measure, 9 to Pica

WHEN, in the course of human events, it becomes necessary for one people to dissolve the political bands which have connected them with another, and to assume, among the powers of the earth, the separate and equal station to which the laws of nature and of nature's God entitle them, a decent respect to the opinions of mankind requires that they should declare the causes which impel them to the separation. We hold these truths to be self-evident, that all men are created equal; that they are endowed by their Creator with certain unalienable rights; that among these are life, liberty and the pursuit of happiness. That, to secure these rights, governments are instituted among men, deriving their just powers from the consent of the governed; that, whenever any form of government

Lower case a to z, 13¾ ems

SERIES No 45—NEWSPAPER STYLE

5½ POINT No 45

WHEN, in the course of human events, it becomes necessary for one people to dissolve the political bands which have connected them with another, and to assume, among the powers of the earth, the separate and equal station to which the laws of nature and of nature's God entitle them, a decent respect to the opinions of mankind requires that they should declare the causes which impel them to the separation. We hold these truths to be self-evident, that all men are created equal; that they are endowed by their Creator with certain unalienable rights; that among these, are life, liberty, and the pursuit of happiness. That, to secure these rights, governments are instituted among men, deriving their just powers from the consent of the governed; that, whenever any form of government becomes destructive of these ends, it is the right of the people to alter or to abolish it, and to institute a new government, laying its foundation on such principles, and organizing its powers in such form, as to them shall seem most likely to effect their safety and happiness. Prudence, indeed, will dictate that governments long established, should not be changed for light and transient causes; and, accordingly, all experience hath shown, that mankind are more disposed to suffer, while evils are sufferable, than to right themselves by abolishing the forms to which they are accustomed. But, when a long train of abuses and usurpations, pursuing invariably the same object, evinces a design to reduce

Lower case a to z, 16 ems

6 POINT No 45

WHEN, in the course of human events, it becomes necessary for one people to dissolve the political bands which have connected them with another, and to assume, among the powers of the earth, the separate and equal station to which the laws of nature and of nature's God entitle them, a decent respect to the opinions of mankind requires that they should declare the causes which impel them to the separation. We hold these truths to be self-evident, that all men are created equal; that they are endowed by their Creator with certain unalienable rights; that among these, are life, liberty, and the pursuit of happiness. That, to secure these rights, governments are instituted among men, deriving their just powers from the consent of the governed; that, whenever any form of government becomes destructive of these ends, it is the right of the people to alter or to abolish it, and to institute a new government, laying its foundation on such principles, and organizing its powers in such form, as to them shall seem most likely to effect their safety and happiness. Prudence, indeed, will dictate that governments long established, should not be changed for light and transient causes; and, accordingly, all experience hath shown, that mankind are more disposed to suffer, while evils are sufferable, than to right them-

Lower case a to z, 16¼ ems

For other sizes of this series, see pages 88 and 89

7 POINT No 45

WHEN, in the course of human events, it becomes necessary for one people to dissolve the political bands which have connected them with another, and to assume, among the powers of the earth, the separate and equal station to which the laws of nature and of nature's God entitle them, a decent respect to the opinions of mankind requires that they should declare the causes which impel them to the separation. We hold these truths to be self-evident, that all men are created equal; that they are endowed by their Creator with certain unalienable rights; that among these, are life, liberty, and the pursuit of happiness. That, to secure these rights, governments are instituted among men, deriving their just powers from the consent of the governed; that, whenever any form of government becomes destructive of these ends, it is the right of the people to alter or to abolish it, and to institute a new government, laying its foundation on such principles, and organizing its powers in such form, as to them shall seem most likely to effect their safety and happiness. Prudence, indeed, will dictate that governments long

Lower case a to z, 15½ ems

8 POINT No 45

WHEN, in the course of human events, it becomes necessary for one people to dissolve the political bands which have connected them with another, and to assume, among the powers of the earth, the separate and equal station to which the laws of nature and of nature's God entitle them, a decent respect to the opinions of mankind requires that they should declare the causes which impel them to the separation. We hold these truths to be self-evident, that all men are created equal; that they are endowed by their Creator with certain unalienable rights; that among these, are life, liberty, and the pursuit of happiness. That, to secure these rights, governments are instituted among men, deriving their just powers from the consent of the governed; that, whenever any form of government becomes destructive of these ends, it is the right of the people to alter or to abolish it, and to institute a new government, laying its foundation on such principles, and or-

Lower case a to z, 14½ ems

SERIES No 46—NEWSPAPER STYLE

6 POINT No 46

WHEN, in the course of human events, it becomes necessary for one people to dissolve the political bands which have connected them with another, and to assume, among the powers of the earth, the separate and equal station to which the laws of nature and of nature's God entitle them, a decent respect to the opinions of mankind requires that they should declare the causes which impel them to the separation. We hold these truths to be self-evident, that all men are created equal; that they are endowed by their Creator with certain unalienable rights; that among these, are life, liberty, and the pursuit of happiness. That, to secure these rights, governments are instituted among men, deriving their just powers from the consent of the governed; that, whenever any form of government becomes destructive of these ends, it is the right of the people to alter or to abolish it, and to institute a new government, laying its foundation on such principles, and organizing its powers in such form, as to them shall seem most likely to effect their safety and happiness. Prudence, indeed, will dictate that governments long established should not be changed for light and transient causes; and, accordingly, all experience hath shown, that mankind are more disposed to suffer, while evils are sufferable, than

Lower case a to z, 16½ ems

7 POINT No 46

WHEN, in the course of human events, it becomes necessary for one people to dissolve the political bands which have connected them with another, and to assume, among the powers of the earth, the separate and equal station to which the laws of nature and of nature's God entitle them, a descent respect to the opinions of mankind requires that they should declare the causes which impel them to the separation. We hold these truths to be self-evident, that all men are created equal; that they are endowed by their Creator with certain unalienable rights; that among these, are life, liberty, and the pursuit of happiness. That, to secure these rights, governments are instituted among men, deriving their just powers from the consent of the governed; that, whenever any form of government becomes destructive of these ends, it is the right of the people to alter or to abolish it, and to institute a new government, laying its foundation on such principles, and organ-

Lower case a to z, 16 ems

For other sizes of this series, see pages 90 and 91

8 POINT No 46

WHEN, in the course of human events, it becomes necessary for one people to dissolve the political bands which have connected them with another, and to assume, among the powers of the earth, the separate and equal station to which the laws of nature and of nature's God entitle them, a decent respect for the opinions of mankind requires that they should declare the causes which impel them to the separation. We hold these truths to be self-evident, that all men are created equal; that they are endowed by their Creator with certain unalienable rights; that among these, are life, liberty, and the pursuit of happiness. That, to secure these rights, governments are instituted among men, deriving their just powers from the consent of the governed; that, whenever any form of government becomes destructive of these ends, it is the right of the people to alter or to abolish it, and to institute a

Lower case a to z, 15½ ems

9 POINT No 46

WHEN, in the course of human events, it becomes necessary for one people to dissolve the political bands which have connected them with another, and to assume, among the powers of the earth, the separate and equal station to which the laws of nature and of nature's God entitle them, a decent respect to the opinions of mankind requires that they should declare the causes which impel them to the separation. We hold these truths to be self-evident, that all men are created equal; that they are also endowed by their Creator with certain unalienable rights; that among these, are life, liberty, and the pursuit of happiness. That, to secure these rights, governments are instituted among men, deriving their just powers from the consent

Lower case a to z, 15 ems

SERIES No 49—NEWSPAPER STYLE

5½ POINT No 49

WHEN, in the course of human events, it becomes necessary for one people to dissolve the political bands which have connected them with another, and to assume, among the powers of the earth, the separate and equal station to which the laws of nature and of nature's God entitle them, a decent respect to the opinions of mankind requires that they should declare the causes which impel them to the separation. We hold these truths to be self-evident, that all men are created equal; that they are endowed by their Creator with certain unalienable rights; that among these, are life, liberty, and the pursuit of happiness. That, to secure these rights, governments are instituted among men, deriving their just powers from the consent of the governed; that, whenever any form of government becomes destructive of these ends, it is the right of the people to alter or to abolish it, and to institute a new government, laying its foundation on such principles, and organizing its powers in such form, as to them shall seem most likely to effect their safety and happiness. Prudence, indeed, will dictate that governments long established, should not be changed for light and transient causes; and, accordingly, all experience hath shown, that mankind are disposed to suffer, while evils are sufferable, than to right themselves by abolishing the forms to which they are accustomed. But, when a long train of abuses and usurpations, pursuing invariably the same object, evinces a design to reduce them under absolute despotism, it is their right, it is

Lower case a to z, 16 ems

6 POINT No 49

WHEN, in the course of human events, it becomes necessary for one people to dissolve the political bands which have connected them with another, and to assume, among the powers of the earth, the separate and equal station to which the laws of nature and of nature's God entitle them, a decent respect to the opinions of mankind requires that they should declare the causes which impel them to the separation. We hold these truths to be self-evident, that all men are created equal; that they are endowed by their Creator with certain unalienable rights; that among these, are life, liberty, and the pursuit of happiness. That, to secure these rights, governments are instituted among men, deriving their just powers from the consent of the governed; that, whenever any form of government becomes destructive of these ends, it is the right of the people to alter or to abolish it, and to institute a new government, laying its foundation on such principles, and organizing its powers in such form, as to them shall seem most likely to effect their safety and happiness. Prudence, indeed, will dictate that governments long established, should not be changed for light and transient causes; and, accordingly, all experience hath shown, that mankind are more disposed to suffer, while evils are sufferable, than to right them-

Lower case a to z, 16 ems

This series also shown on page 95

7 POINT No 49

WHEN, in the course of human events, it becomes necessary for one people to dissolve the political bands which have connected them with another, and to assume, among the powers of the earth, the separate and equal station to which the laws of nature and of nature's God entitle them, a decent respect to the opinions of mankind requires that they shall declare the causes which impel them to the separation. We hold these truths to be self-evident, that all men are created equal; that they are endowed by their Creator with certain unalienable rights; that among these, are life, liberty, and the pursuit of happiness. That, to secure these rights, governments are instituted among men, deriving their just powers from the consent of the governed; that, whenever any form of government becomes destructive of these ends, it is the right of the people to alter or to abolish it, and to institute a new government, laying its foundation on such principles, and organizing its powers in such form, as to them shall seem most likely to effect their safety and happiness. Prudence, indeed, will dictate that governments long established, should not be

Lower case a to z, 15½ ems

8 POINT No 49

WHEN, in the course of human events, it becomes necessary for one people to dissolve the political bands which have connected them with another, and to assume, among the powers of the earth, the separate and equal station to which the laws of nature and of nature's God entitle them, a decent respect to the opinions of mankind requires that they should declare the causes which impel them to the separation. We hold these truths to be self-evident, that all men are created equal; that they are endowed by their Creator with certain unalienable rights; that among these, are life, liberty, and the pursuit of happiness. That, to secure these rights, governments are instituted among men, deriving their just powers from the consent of the governed; that, whenever any form of government becomes destructive to these ends, it is the right of the people to alter or to abolish it, and to institute a new government, laying its foundation on such principles, and organ-

Lower case a to z, 14½ ems

SERIES No 50—NEWSPAPER STYLE

6 POINT No 50

WHEN, in the course of human events, it becomes necessary for one people to dissolve the political bands which have connected them with another, and to assume, among the powers of the earth, the separate and equal station to which the laws of nature and of nature's God entitle them, a decent respect to the opinion of mankind requires that they should declare the causes which impel them to the separation. We hold these truths to be self-evident, that all men are created equal; that they are endowed by their Creator with certain unalienable rights; that among these, are life, liberty, and the pursuit of happiness. That, to secure these rights, governments are instituted among men, deriving their just powers from the consent of the governed; that, whenever any form of government becomes destructive of these ends, it is the right of the people to alter or to abolish it, and to institute a new government, laying its foundation on such principles, and organizing its powers in such form, as to them shall seem most likely to effect their safety and happiness. Prudence, indeed, will dictate that governments long established, should not be changed for light and transient causes; and, accordingly, all experience hath shown, that mankind are more disposed to suffer, while evils are sufferable, than to right themselves by abol-

Lower case a to z, 15¾ ems

7 POINT No 50

WHEN, in the course of human events, it becomes necessary for one people to dissolve the political bands which have connected them with another, and to assume, among the powers of the earth, the separate and equal station to which the laws of nature and of nature's God entitle them, a decent respect to the opinions of mankind requires that they should declare the causes which impel them to the separation. We hold these truths to be self-evident, that all men are created equal; that they are endowed by their Creator with certain unalienable rights; that among these, are life, liberty, and pursuit of happiness. That, to secure these rights, governments are instituted among men, deriving their just powers from the consent of the governed; that, whenever any form of government becomes destructive of these ends, it is the right of the people to alter or to abolish it, and to institute a new government, laying its foundation on such principles, and organizing its powers in such form, as to them shall seem most

Lower case a to z, 14¾ ems

For other sizes of this series, see pages 96 and 97

8 POINT No 50

WHEN, in the course of human events, it becomes necessary for one people to dissolve the political bands which have connected them with another, and to assume, among the powers of the earth, the separate and equal station to which the laws of nature and of nature's God entitle them, a decent respect to the opinions of mankind requires that they should declare the causes which impel them to the separation. We hold these truths to be self-evident, that all men are created equal; that they are endowed by their Creator with certain unalienable rights; that among these are life, liberty, and the pursuit of happiness. That, to secure these rights, governments are instituted among men, deriving their just powers from the consent of the governed; that, whenever any form of government becomes destructive of these ends, it is the right of the people to alter or to abolish it, and to institute a new government, laying its foundation on

Lower case a to z, 14 ems

9 POINT No 50

WHEN, in the course of human events, it becomes necessary for one people to dissolve the political bands which have connected them with another, and to assume, among the powers of the earth, the separate and equal station to which the laws of nature and of nature's God entitle them, a decent respect to the opinions of mankind requires that they should declare the causes which impel them to the separation. We hold these truths to be self-evident, that all men are created equal; that they are endowed by their Creator with certain unalienable rights;—among these, are life, liberty, and pursuit of happiness. That, to secure these rights, governments are instituted among men, deriving their just powers from the consent of the governed; that, whenever any form of government be-

Lower case a to z, 14 ems

INLAND SERIES No 56—NEWSPAPER STYLE

5½ POINT NO 56

WHEN, in the course of human events, it becomes necessary for one people to dissolve the political bands which have connected them with another, and to assume, among the powers of the earth, the separate and equal station, to which the laws of nature and of nature's God entitle them, a decent respect to the opinions of mankind requires that they should declare the causes which impel them to the separation. We hold these truths to be self-evident, that all men are created equal; that they are endowed by their creator with certain unalienable rights; that among these, are life, liberty, and the pursuit of happiness. That, to secure these rights, governments are instituted among men, deriving their just powers from the consent of the governed; that, whenever any form of government becomes destructive of these ends, it is the right of the people to alter or to abolish it, and to institute a new government, laying its foundation on such principles, and organizing its powers in such form, as to them shall seem most likely to effect their safety and happiness. Prudence, indeed, will dictate that governments long established, should not be changed for light and transient causes; and, accordingly, all experience hath shown, that mankind are more disposed to suffer, while evils are sufferable, than to right themselves by abolishing the forms to which they are accustomed. But, when a long train of abuses and usurpations, pursuing in-

Lower case a to z, 17½ ems

6 POINT NO 56

WHEN, in the course of human events, it becomes necessary for one people to dissolve the political bands which have connected them with another, and to assume, among the powers of the earth, the separate and equal station to which the laws of nature and of nature's God entitle them, a decent respect to the opinions of mankind requires that they should declare the causes which impel them to the separation. We hold these truths to be self-evident, that all men are created equal; that they are endowed by their Creator with certain unalienable rights; that among these, are life, liberty, and the pursuit of happiness. That, to secure these rights, governments are instituted among men, deriving their just powers from the consent of the governed; that, whenever any form of government becomes destructive of these ends, it is the right of the people to alter or to abolish it, and to institute a new government, laying its foundation on such principles, and organizing its powers in such form, as to them shall seem most likely to effect their safety and happiness. Prudence, indeed, will dictate that governments long established, should not be changed for light and transient causes; and, accordingly, all experience

Lower case a to z, 18 ems

For other sizes of this series, see pages 98 and 99

7 POINT NO 56

WHEN, in the course of human events, it becomes necessary for one people to dissolve the political bands which have connected them with another, and to assume, among the powers of the earth, the separate and equal station to which the laws of nature and of nature's God entitle them, a decent respect to the opinions of mankind requires that they should declare the causes which impel them to the separation. We hold these truths to be self-evident, that all men are created equal; that they are endowed by their Creator with certain unalienable rights; that among these, are life, liberty, and the pursuit of happiness. That, to secure these rights, governments are instituted among men, deriving their power from the consent of the governed; that, whenever any form of government becomes destructive of these ends, it is the right of the people to alter or to abolish it, and to institute a new government, laying its foundation on such principles, and organizing its powers in such form, as to them shall seem most likely to effect their safety and happiness.

Lower case a to z, 17 ems

8 POINT NO 56

WHEN, in the course of human events, it becomes necessary for one people to dissolve the political bands which have connected them with another, and to assume, among the powers of the earth, the separate and equal station to which the laws of nature and of nature's God entitle them, a decent respect to the opinions of mankind requires that they should declare the causes which impel them to the separation. We hold these truths to be self-evident, that all men are created equal; that they are endowed by their creator with certain unalienable rights; that among these, are life, liberty, and the pursuit of happiness. That, to secure these rights, governments are instituted among men, deriving their just powers from the consent of the governed; that, whenever any form of government becomes destructive of these ends, it is the right of the people to alter or to

Lower case a to z, 15¾ ems

SERIES No 57—NEWSPAPER STYLE

6 POINT NO 57

WHEN, in the course of human events, it becomes necessary for one people to dissolve the political bands which have connected them with another, and to assume, among the powers of the earth, the separate and equal station to which the laws of nature and of nature's God entitle them, a decent respect to the opinions of mankind requires that they should declare the causes which impel them to the separation. We hold these truths to be self-evident, that all men are created equal; that they are endowed by their Creator with certain unalienable rights; that among these, are life, liberty, and the pursuit of happiness. That, to secure these rights, governments are instituted among men, deriving their just powers from the consent of the governed; that, whenever any government becomes destructive of these ends, it is the right of the people to alter or to abolish it, and to institute a new government, laying its foundation on such principles, and organizing its powers in such form, as to them shall seem most likely to effect their safety and happiness. Prudence, indeed, will dictate that governments long established, should not be changed for light and transient causes; and, accordingly, all experience hath shown, that mankind are more disposed to suffer, while evils are sufferable, than to right themselves by

Lower case a to z, 16 ems

7 POINT NO 57

WHEN, in the course of human events, it becomes necessary for one people to dissolve the political bands which have connected them with another, and to assume, among the powers of the earth, the separate and equal station to which the laws of nature and of nature's God entitle them, a decent respect to the opinions of mankind requires that they should declare the causes which impel them to the separation. We hold these truths to be self-evident, that all men are created equal; that they are endowed by their Creator with certain unalienable rights; that among these, are life, liberty, and the pursuit of happiness. That, to secure these rights, governments are instituted among men, deriving their just powers from the consent of the governed; that, whenever any form of government becomes destructive of these ends, it is the right of the people to alter or to abolish it, and to institute a new government, laying its foundation on such principles, and organizing its powers in such form, as to them shall seem

Lower case a to z, 14¾ ems

For other sizes of this series, see pages 100 and 101

8 POINT NO 57

WHEN, in the course of human events, it becomes necessary for one people to dissolve the political bands which have connected them with another, and to assume, among the powers of the earth, the separate and equal station to which the laws of nature and of nature's God entitle them, a decent respect for the opinions of mankind requires that they should declare the causes which impel them to the separation. We hold these truths to be self-evident, that all men are created equal; that they are endowed by their Creator with certain unalienable rights; that among these are life, liberty, and the pursuit of happiness. That, to secure these rights, governments are instituted among men, deriving their just powers from the consent of the governed; that, whenever any form of government becomes destructive of these ends, it is the right of the people to alter or to abolish it, and to institute a new government, laying its founda-

Lower case a to z, 14 ems

9 POINT NO 57

WHEN, in the course of human events, it becomes necessary for one people to dissolve the political bands which have connected them with another, and to assume, among the powers of the earth, the separate and equal station to which the laws of nature and of nature's God entitle them, a decent respect to the opinions of mankind requires that they should declare the causes which impel them to the separation. We hold these truths to be self-evident, that all men are created equal; that they are endowed by their Creator with certain unalienable rights; that among these, are life, liberty, and the pursuit of happiness. That, to secure these rights, governments are instituted among men, deriving their just powers from the consent of the governed; that, whenever any form of government becomes destructive and

Lower case a to z, 13¾ ems

SCRIPPS SERIES No 58—NEWSPAPER STYLE

8½ POINT No 58

WHEN, in the course of human events, it becomes necessary for one people to dissolve the political bands which have connected them with another, and to assume, among the powers of the earth, the separate and equal station to which the laws of nature and of nature's God entitle them, a decent respect to the opinions of mankind requires that they should declare the causes which impel them to the separation. We hold these truths to be self-evident, that all men are created equal; that they are endowed by their Creator with certain unalienable rights; that among these, are life, liberty, and the pursuit of happiness. That, to secure these rights, governments are instituted among men, deriving their just powers from the consent of the governed; that, whenever any form of government becomes destructive of these ends, it is the right of the people to alter or to abolish it, and to institute a new government, laying its foundation on such principles, and organizing its powers in such form, as to them shall seem most likely to effect their safety and happiness. Prudence, indeed, will dictate that governments long established, should not be changed for light and transient causes; and, accordingly, all experience hath shown, that mankind are more disposed to suffer, while evils are sufferable, than to right themselves by abolishing the forms to which they are accustomed. But, when a long train of abuses and usurpations, pursuing invariably the same object, evinces a design to reduce

Lower case a to z, 16½ ems

6 POINT No 58

WHEN, in the course of human events, it becomes necessary for one people to dissolve the political bands which have connected them with another, and to assume, among the powers of the earth, the separate and equal station to which the laws of nature and of nature's God entitle them, a decent respect to the opinions of mankind requires that they should declare the causes which impel them to the separation. We hold these truths to be self-evident, that all men are created equal; that they are endowed by their Creator with certain unalienable rights; that among these, are life, liberty and the pursuit of happiness. That, to secure these rights, governments are instituted among men, deriving their just powers from the consent of the governed; that, whenever any form of government becomes destructive of these ends, it is the right of the people to alter or to abolish it, and to institute a new government, laying its foundation on such principles, and organizing its powers in such form, as to them shall seem most likely to effect their safety and happiness. Prudence, indeed, will dictate that governments long established, should not be changed for light and transient causes; and, accordingly, all experience hath shown, that mankind are more disposed to suffer, while evils are

Lower case a to z, 16½ ems

For other sizes of this series, see pages 102 and 103

7 POINT No 58

WHEN, in the course of human events, it becomes necessary for one people to dissolve the political bands which have connected them with another, and to assume, among the powers of the earth, the separate and equal station to which the laws of nature and of nature's God entitle them, a decent respect to the opinions of mankind requires that they should declare the causes which impel them to the separation. We hold these truths to be self-evident, that all men are created equal; that they are endowed by their Creator with certain unalienable rights; that among these, are life, liberty, and the pursuit of happiness. That, to secure these rights, governments are instituted among men, deriving their just powers from the consent of the governed; that, whenever any form of government becomes destructive of these ends, it is the right of the people to alter or to abolish it, and to institute a new government, laying its foundation on such principles, and organizing its powers in such form, as to them shall seem most likely to effect their safety and happiness. Prudence, indeed, will dictate that governments long established,

Lower case a to z, 15¾ ems

8 POINT No 58

WHEN, in the course of human events, it becomes necessary for one people to dissolve the political bands which have connected them with another, and to assume, among the powers of the earth, the separate and equal station to which the laws of nature and of nature's God entitle them, a decent respect to the opinions of mankind requires that they should declare the causes which impel them to the separation. We hold these truths to be self-evident, that all men are created equal; that they are endowed by their Creator with certain unalienable rights; that among these, are life, liberty, and the pursuit of happiness. That, to secure these rights, governments are instituted among men, deriving their just powers from the consent of the governed; that, whenever any form of government becomes destructive of these ends, it is the right of the people to alter or to abolish it, and to institute a new government, laying its found-

Lower case a to z, 14¾ ems

AMERICAN PRESS ASSOCIATION SERIES No 61

6 POINT No 61

WHEN, in the course of human events, it becomes necessary for one people to dissolve the political bands which have connected them with another, and to assume, among the powers of the earth, the separate and equal station to which the laws of nature and of nature's God entitle them, a decent respect to the opinions of mankind requires that they should declare the causes which impel them to the separation. We hold these truths to be self-evident, that all men are created equal; that they are endowed by their Creator with certain unalienable rights; that among these, are life, liberty, and the pursuit of happiness. That, to secure these rights, governments are founded among men, deriving their just powers from the consent of the governed; that, whenever any form of government becomes destructive of these ends, it is the right of the people to alter or to abolish it, and to institute a new government, laying its foundation on such principles, and organizing its powers in such form, as to them shall seem most likely to effect their safety and happiness. Prudence, indeed, will dictate that governments long established, should not be changed for light and transient causes; and, accordingly, all experience hath shown, that mankind are more disposed to suffer, while evils are sufferable,

Lower case a to z, 16 $\frac{3}{4}$ ems

7 POINT No 61

WHEN, in the course of human events, it becomes necessary for one people to dissolve the political bands which have connected them with another, and to assume, among the powers of the earth, the separate and equal station to which the laws of nature and of nature's God entitle them, a decent respect to the opinions of mankind requires that they should declare the causes which impel them to the separation. We hold these truths to be self-evident, that all men are created equal; that they are endowed by their Creator with certain unalienable rights; that among these, are life, liberty, and the pursuit of happiness. That, to secure these rights, governments are instituted among men, deriving their just powers from the consent of the governed; that, whenever any form of government becomes destructive of these ends, it is the right of the people to alter or to abolish it, and to institute a new government, laying its foundation on such principles, and organizing its powers in such form, as to

Lower case a to z, 15 $\frac{3}{4}$ ems

For other showing of this series, see page 105

8 POINT No 61

WHEN, in the course of human events, it becomes necessary for one people to dissolve the political bands which have connected them with another, and to assume, among the powers of the earth, the separate and equal station to which the laws of nature and of nature's God entitle them, a decent respect to the opinions of mankind requires that they should declare the causes which impel them to the separation. We hold these truths to be self-evident, that all men are created equal; that they are endowed by their creator with certain unalienable rights; that among these, are life, liberty, and the pursuit of happiness. That, to secure these rights, governments are instituted among men, deriving their just powers from the consent of the governed; that, whenever any form of government becomes destructive of these ends, it is the right of the people to alter or to abolish it, and to institute a new government, laying its foundation on such principles, and

Lower case a to z, 14 $\frac{1}{2}$ ems

9 POINT No 61

WHEN, in the course of human events it becomes necessary for one people to dissolve the political bands which connect them with another, and to assume, among the powers of the earth, the separate and equal station to which the laws of nature and of nature's God entitle them, a decent respect to the opinions of mankind requires that they should declare the causes which impel them to the separation. We hold these truths to be self-evident, that all men are created equal; that they are endowed by their Creator with certain unalienable rights; that among these, are life, liberty, and the pursuit of happiness. That, to secure these rights, governments are instituted among men, deriving their just powers from the consent of the governed; that, whenever any form of government

Lower case a to z, 15 $\frac{3}{4}$ ems

OHIO SERIES—NEWSPAPER STYLE

5½ POINT No 62 " "

WHEN, in the course of human events, it becomes necessary for one people to dissolve the political bands which have connected them with another, and to assume, among the powers of the earth, the separate and equal station to which the laws of nature and of nature's God entitle them, a decent respect to the opinions of mankind requires that they should declare the causes which impel them to the separation. We hold these truths to be self-evident, that all men are created equal; that they are endowed by their Creator with certain unalienable rights; that among these, are life, liberty, and the pursuit of happiness. That, to secure these rights, governments are instituted among men, deriving their just powers from the consent of the governed; that, whenever any government becomes destructive of these ends, it is the right of the people to alter or to abolish it, and to institute a new government, laying its foundation on such principles, and organizing its powers in such form, as to them shall seem most likely to effect their safety and happiness. Prudence, indeed, will dictate that governments long established, should not be changed for light and transient causes; and, accordingly, all experience hath shown, that mankind are more disposed to suffer, while evils are sufferable, than to right themselves by abolishing the forms to which they are accustomed. But, when a long train of abuses and usurpations, pursuing invariably the same object, evinces a design to reduce them under absolute despotism, it is their right, it is their duty, to throw off such government, and to provide new guards for their future secur-

Lower case a to z, 15 ems

6 POINT No 116 " "

WHEN, in the course of human events, it becomes necessary for one people to dissolve the political bands which have connected them with another, and to assume, among the powers of the earth, the separate and equal station to which the laws of nature and of nature's God entitle them, a decent respect to the opinions of mankind requires that they should declare the causes which impel them to the separation. We hold these truths to be self-evident, that all men are created equal; that they are endowed by their Creator with certain unalienable rights; that among these, are life, liberty, and the pursuit of happiness. That, to secure these rights, governments are instituted among men, deriving their just powers from the consent of the governed; that, whenever any form of government becomes destructive of these ends, it is the right of the people to alter or to abolish it, and to institute a new government, laying its foundation on such principles, and organizing its powers in such form, as to them shall seem most likely to effect their safety and happiness. Prudence, indeed, will dictate that governments long established, should not be changed for light and transient causes; and, accordingly, all experience hath shown, that mankind are more disposed to suffer, while evils are sufferable, than to right themselves by abolishing the forms to which they

Lower case a to z, 15 3/4 ems

For other sizes of this series, see page 106

7 POINT No 62 " "

WHEN, in the course of human events, it becomes necessary for one people to dissolve the political bands which have connected them with another, and to assume, among the powers of the earth, the separate and equal station to which the laws of nature and of nature's God entitle them, a decent respect to the opinions of mankind requires that they should declare the causes which impel them to the separation. We hold these truths to be self-evident, that all men are created equal; that they are endowed by their Creator with certain unalienable rights; that among these, are life, liberty, and the pursuit of happiness. That, to secure these rights, governments are instituted among men, deriving their just powers from the consent of the governed; that, whenever any form of government becomes destructive of these ends, it is the right of the people to alter or to abolish it, and to institute a new government, laying its foundation on such principles, and organizing its powers in such form, as to them shall seem most likely to effect their safety and happiness. Prudence, indeed, will dictate that governments long established, should not be changed for light and transient causes;

Lower case a to z, 14 3/4 ems

8 POINT No 62 " "

WHEN, in the course of human events, it becomes necessary for one people to dissolve the political bands which have connected them with another, and to assume, among the powers of the earth, the separate and equal station to which the laws of nature and of nature's God entitle them, a decent respect to the opinions of mankind requires that they should declare the causes which impel them to the separation. We hold these truths to be self-evident, that all men are created equal; that they are endowed by their Creator with certain unalienable rights; that among these, are life, liberty, and the pursuit of happiness. That, to secure these rights, governments are instituted among men, deriving their just powers from the consent of the governed; that, whenever any form of government becomes destructive of these ends, it is the right of the people to alter or to abolish it, and to institute a new government,

Lower case a to z, 14 3/4 ems

KENTUCKY SERIES—NEWSPAPER STYLE

6 POINT NO 62

WHEN, in the course of human events, it becomes necessary for one people to dissolve the political bands which have connected them with another, and to assume, among the powers of the earth, the separate and equal station to which the laws of nature and of nature's God entitle them, a decent respect to the opinions of mankind requires that they should declare the causes which impel them to the separation. We hold these truths to be self-evident, that all men are created equal; that they are endowed by their Creator with certain unalienable rights; that among these, are life, liberty, and the pursuit of happiness. That, to secure these rights, governments are instituted among men, deriving their just powers from the consent of the governed; that, whenever any form of government becomes destructive of these ends, it is the right of the people to alter or to abolish it, and to institute a new government, laying its foundation on such principles, and organizing its powers in such form, as to them shall seem most likely to effect their safety and happiness. Prudence, indeed, will dictate that governments long established, should not be changed for light and transient causes; and, accordingly, all experience hath shown, that mankind are more disposed to suffer, while evils are sufferable, than to right themselves

Lower case a to z, 16½ ems

7 POINT NO 69

WHEN, in the course of human events, it becomes necessary for one people to dissolve the political bands which have connected them with another, and to assume, among the powers of the earth, the separate and equal station to which the laws of nature and of nature's God entitle them, a decent respect to the opinions of mankind requires that they should declare the causes which impel them to the separation. We hold these truths to be self-evident, that all men are created equal; that they are endowed by their Creator with certain unalienable rights; that among these, are life, liberty, and the pursuit of happiness. That, to secure these rights, governments are instituted among men, deriving their just powers from the consent of the governed; that, whenever any form of government becomes destructive of these ends, it is the right of the people to alter or to abolish it, and to institute a new government, laying its foundation on such principles, and organizing its powers in such form, as to them shall seem most likely

Lower case a to z, 15 1-5 ems

For other sizes of this series, see page 107

8 POINT NO 69

WHEN, in the course of human events, it becomes necessary for one people to dissolve the political bands which have connected them with another, and to assume, among the powers of the earth, the separate and equal station to which the laws of nature and of nature's God entitle them, a decent respect to the opinions of mankind requires that they should declare the causes which impel them to the separation. We hold these truths to be self-evident, that all men are created equal; that they are endowed by their Creator with certain unalienable rights; that among these, are life, liberty, and the pursuit of happiness. That, to secure these rights, governments are instituted among men, deriving their just powers from the consent of the governed; that, whenever any form of government becomes destructive of these ends, it is the right of the people to alter or to abolish it, and to institute a new government, laying its founda-

Lower case a to z, 15 ems

9 POINT NO 69

WHEN, in the course of human events, it becomes necessary for one people to dissolve the political bands which have connected them with another, and to assume, among the powers of the earth, the separate and equal station to which the laws of nature and of nature's God entitle them, a decent respect to the opinions of mankind requires that they should declare the causes which impel them to the separation. We hold these truths to be self-evident, that all men are created equal; that they are endowed by their Creator with certain unalienable rights; that among these, are life, liberty, and the pursuit of happiness. That, to secure these rights, governments are instituted among men, deriving their just powers from the consent of the governed; that, whenever any form of government becomes

Lower case a to z, 15 4-5 ems

MODERN ROMANS SHOWN BY SIZES

Same faces shown by series on pages 85 to 112

3 1/2 POINT NO 17

When, in the course of human events, it becomes necessary for one people to dissolve the political bands which have connected them with another, and to assume, among the powers of the earth, the separate and equal station to which the laws of nature and of nature's God entitle them, a decent respect to the opinions of mankind requires that they should declare the causes which impel them to the separation. We hold these truths to be self-evident, that all men are created equal; that they are endowed by their Creator with certain unalienable rights; that among these, are life, liberty, and the pursuit of happiness. That, to secure these rights, governments are instituted among men, deriving their just powers from the consent of the governed; that, whenever any form of government becomes destructive of these ends, it is the right of the people to alter or to abolish it, and to institute a new government, laying its foundation on such principles, and organizing its powers in such form, as to them shall seem most likely to effect their safety and happiness. Prudence, indeed, will dictate that governments long established, should not be changed for light and transient causes; and, accordingly, all experience hath shown, that mankind are more disposed to suffer, while evils are sufferable, than to right themselves by abolishing the forms to which they are accustomed. But, when a long train of abuses and usurpations, pursuing invariably the same object, evinces a design to reduce them to absolute despotism, it is their right, it is their duty, to throw off such government, and to provide new guards for their future security. Such has been the patient sufferance of these colonies, and such is now the necessity which constrains them to alter their former system of government. The history of the present king of Great Britain is a history of repeated injuries and usurpations, all having, in direct object,

ABCDEFGHIJKLMNQRSTUUVWXYZ
1234567890

4 1/2 POINT NO 17

When, in the course of human events, it becomes necessary for one people to dissolve the political bands which are connected them with another, and to assume, among the powers of the earth, the separate and equal station to which the laws of nature and of nature's God entitle them, a decent respect to the opinions of mankind requires that they should declare the causes which impel them to the separation. We hold these truths to be self-evident, that all men are created equal; that they are endowed by their Creator with certain unalienable rights; that among these, are life, liberty, and the pursuit of happiness. That, to secure these rights, governments are instituted among men, deriving their just powers from the consent of the governed; that, whenever any form of government becomes destructive of these ends, it is the right of the people to alter or to abolish it, and to institute a new government, laying its foundation on such principles, and organizing its powers in such form, as to them shall seem most likely to effect their safety and happiness. Prudence, indeed, will dictate that governments long established, should not be changed for light and transient causes; and, accordingly, all experience hath shown, that mankind are more disposed to suffer, while evils are sufferable, than to right themselves by abolishing the forms to which they are accustomed. But, when a long train of abuses and usurpations, pursuing invariably the same object, evinces a design to reduce them to absolute despotism, it is their right, it is their duty, to throw off such government, and to provide new guards for their future security. Such has been the patient sufferance of these colonies, and such is now the necessity which constrains them to alter their former system of government. The history of the present king of Great Britain is a history of repeated injuries and usurpations, all having, in direct object,

ABCDEFGHIJKLMNQRSTUUVWXYZ
1234567890

5 POINT NO 57

When, in the course of human events, it becomes necessary for one people to dissolve the political bands which have connected them with another, and to assume, among the powers of the earth, the separate and equal station to which the laws of nature and of nature's God entitle them, a decent respect to the opinions of mankind requires that they should declare the causes which impel them to the separation. We hold these truths to be self-evident, that all men are created equal; that they are endowed by their Creator with certain unalienable rights; that among these, are life, liberty, and the pursuit of happiness. That, to secure these rights, governments are instituted among men, deriving their just powers from the consent of the governed; that, whenever any form of government becomes destructive of these ends, it is the right of the people to alter or to abolish it, and to institute a new government, laying its foundation on such principles, and organizing its powers in such form, as to them shall seem most likely to effect their safety and happiness. Prudence, indeed, will dictate that governments long established, should not be changed for light and transient causes; and, accordingly, all experience hath shown, that mankind are more disposed to suffer, while evils are sufferable, than to right themselves by abolishing the forms to which they are accustomed. But, when a long train of abuses and usurpations, pursuing invariably the same object, evinces a design to reduce them to absolute despotism, it is their right, it is their duty, to throw off such government, and to provide new guards for their future security. Such has been the patient sufferance of these colonies, and such is now the necessity which constrains them to alter their former system of government. The history of the present king of Great Britain is a history of repeated injuries and usurpations, all having, in direct object,

Lower case a to z, 17 cms
ABCDEFGHIJKLMNQRSTUUVWXYZ
1234567890

5

4 1/2 POINT NO 18

When, in the course of human events, it becomes necessary for one people to dissolve the political bands which have connected them with another, and to assume, among the powers of the earth, the separate and equal station to which the laws of nature and of nature's God entitle them, a decent respect to the opinions of mankind requires that they should declare the causes which impel them to the separation. We hold these truths to be self-evident, that all men are created equal; that they are endowed by their Creator with certain unalienable rights; that among these, are life, liberty, and the pursuit of happiness. That, to secure these rights, governments are instituted among men, deriving their just powers from the consent of the governed; that, whenever any form of government becomes destructive of these ends, it is the right of the people to alter or to abolish it, and to institute a new government, laying its foundation on such principles, and organizing its powers in such form, as to them shall seem most likely to effect their safety and happiness. Prudence, indeed, will dictate that governments long established, should not be changed for light and transient causes; and, accordingly, all experience hath shown, that mankind are more disposed to suffer, while evils are sufferable, than to right themselves by abolishing the forms to which they are accustomed. But, when a long train of abuses and usurpations, pursuing invariably the same object, evinces a design to reduce them to absolute despotism, it is their right, it is their duty, to throw off such government, and to provide new guards for their future security. Such has been the patient sufferance of these colonies, and such is now the necessity which constrains them to alter their former system of government. The history of the present king of Great Britain is a history of repeated injuries and usurpations, all having, in direct object,

ABCDEFGHIJKLMNQRSTUUVWXYZ
1234567890

5 POINT NO 45

When, in the course of human events, it becomes necessary for one people to dissolve the political bands which have connected them with another, and to assume, among the powers of the earth, the separate and equal station to which the laws of nature and of nature's God entitle them, a decent respect to the opinions of mankind requires that they should declare the causes which impel them to the separation. We hold these truths to be self-evident, that all men are created equal; that they are endowed by their Creator with certain unalienable rights; that among these, are life, liberty, and the pursuit of happiness. That, to secure these rights, governments are instituted among men, deriving their just powers from the consent of the governed; that, whenever any form of government becomes destructive of these ends, it is the right of the people to alter or to abolish it, and to institute a new government, laying its foundation on such principles, and organizing its powers in such form, as to them shall seem most likely to effect their safety and happiness. Prudence, indeed, will dictate that governments long established, should not be changed for light and transient causes; and, accordingly, all experience hath shown, that mankind are more disposed to suffer, while evils are sufferable, than to right themselves by abolishing the forms to which they are accustomed. But, when a long train of abuses and usurpations, pursuing invariably the same object, evinces a design to reduce them to absolute despotism, it is their right, it is their duty, to throw off such government, and to provide new guards for their future security. Such has been the patient sufferance of these colonies, and such is now the necessity which constrains them to alter their former system of government. The history of the present king of Great Britain is a history of repeated injuries and usurpations, all having, in direct object,

Lower case a to z, 15 3/4 cms
ABCDEFGHIJKLMNQRSTUUVWXYZ
1234567890

5 POINT NO 46

When, in the course of human events, it becomes necessary for one people to dissolve the political bands which have united them with another, and to assume, among the powers of the earth, the separate and equal station to which the laws of nature and of nature's God entitle them, a decent respect to the opinions of mankind requires that they should declare the causes which impel them to the separation. We hold these truths to be self-evident, that all men are created equal; that they are endowed by their Creator with certain unalienable rights; that among these, are life, liberty, and the pursuit of happiness. That, to secure these rights, governments are instituted among men, deriving their just powers from the consent of the governed; that, whenever any form of government becomes destructive of these ends, it is the right of the people to alter or to abolish it, and to institute a new government, laying its foundation on such principles, and organizing its powers in such form, as to them shall seem most likely to effect their safety and happiness. Prudence, indeed, will dictate that governments long established, should not be changed for light and transient causes; and, accordingly, all experience hath shown, that mankind are more disposed to suffer, while evils are sufferable, than to right themselves by abolishing the forms to which they are accustomed. But, when a long train of abuses and usurpations, pursuing invariably the same object, evinces a design to reduce them to absolute despotism, it is their right, it is their duty, to throw off such government, and to provide new guards for their future security. Such has been the patient sufferance of these colonies, and such is now the necessity which constrains them to alter their former system of government. The history of the present king of Great Britain is a history of repeated injuries and usurpations, all having, in direct object,

Lower case a to z, 17 cms
ABCDEFGHIJKLMNQRSTUUVWXYZ
1234567890

5½ POINT NO 62

WHEN, in the course of human events, it becomes necessary for one people to dissolve the political bands which have connected them with another, and to assume, among the powers of the earth, the separate and equal station to which the laws of nature and of nature's God entitle them, a decent respect to the opinions of mankind requires that they should declare the causes which impel them to the separation. We hold these truths to be self-evident, that all men are created equal; that they are endowed by their Creator with certain unalienable rights; that among these, are life, liberty, and pursuit of happi-

Lower case a to z, 15 ems

ABCDEFGHIJKLMNPOQRSTUVWXYZ
1234567890

5½ POINT NO 57

WHEN, in the course of human events, it becomes necessary for one people to dissolve the political bands which have connected them with another, and to assume, among the powers of the earth, the separate and equal station to which the laws of nature and of nature's God entitle them, a decent respect to the opinions of mankind requires that they should declare the causes which impel them to the separation. We hold these truths to be self-evident, that all men are created equal; that they are endowed by their Creator with certain unalienable rights; that among these, are life,

Lower case a to z, 16 ems

ABCDEFGHIJKLMNPOQRSTUVWXYZ
1234567890

5½ POINT NO 46

WHEN, in the course of human events, it becomes necessary for one people to dissolve the political bands which have connected them with another, and to assume, among the powers of the earth, the separate and equal station to which the laws of nature and of nature's God entitle them, a decent respect to the opinions of mankind requires that they should declare the causes which impel them to the separation. We hold these truths to be self-evident, that all men are created equal; that they are endowed by their Creator with certain unalienable rights; that among these, are life, liberty, and the pursuit of happiness. That, to secure these rights, governments are instituted among men, deriving their just powers from the consent of the governed; that, whenever any form of government becomes destructive of these ends, it is the right of the people to alter or to abolish it, and to institute a new government, laying its foundation on such principles, and organizing its powers in such form, as to them shall seem most likely to effect their safety and happiness. Prudence, indeed, will dictate that governments long established, should not be changed for light and transient causes; and, accordingly, all experience hath shewn, that mankind are

Lower case a to z, 16 ems

ABCDEFGHIJKLMNPOQRSTUVWXYZ
1234567890

5½ POINT NO 45

WHEN, in the course of human events, it becomes necessary for one people to dissolve the political bands which have connected them with another, and to assume, among the powers of the earth, the separate and equal station to which the laws of nature and of nature's God entitle them, a decent respect to the opinions of mankind requires that they should declare the causes which impel them to the separation. We hold these truths to be self-evident, that all men are created equal; that they are endowed by their Creator with certain unalienable rights; that among these are life, liberty, and the pursuit of happiness. That, to secure these rights, governments are instituted among men, deriving their just powers from the consent of the governed; that, whenever any form of government becomes destructive of these ends, it is the right of the people to alter or to abolish it, and to institute a new government, laying its foundation on such principles and organizing its powers in such form, as to them shall seem most likely to effect their safety and happiness. Prudence, indeed, will dictate that governments long established, should not be changed for light and transient causes; and, accordingly, all experience hath shewn, that

Lower case a to z, 16 ems

ABCDEFGHIJKLMNPOQRSTUVWXYZ
1234567890

5½ POINT NO 47

WHEN, in the course of human events, it becomes necessary for one people to dissolve the political bands which have connected them with another, and to assume, among the powers of the earth, the separate and equal station to which the laws of nature and of nature's God entitle them, a decent respect to the opinions of mankind requires that they should declare the causes which impel them to the separation. We hold these truths to be self-evident, that all men are created equal; that they are endowed by their Creator with certain unalienable rights; that among these, are life, liberty, and the pursuit of

Lower case a to z, 15 ems

ABCDEFGHIJKLMNPOQRSTUVWXYZ
1234567890

5½ POINT NO 40

WHEN, in the course of human events, it becomes necessary for one people to dissolve the political bands which have connected them with another, and to assume, among the powers of the earth, the separate and equal station to which the laws of nature and of nature's God entitle them, a decent respect to the opinions of mankind requires that they should declare the causes which impel them to the separation. We hold these truths to be self-evident, that all men are created equal; that they are endowed by their Creator with certain unalienable rights; that among these, are life,

Lower case a to z, 16 ems

ABCDEFGHIJKLMNPOQRSTUVWXYZ
1234567890

5½ POINT NO 58 °

WHEN, in the course of human events, it becomes necessary for one people to dissolve the political bands which have connected them with another, and to assume, among the powers of the earth, the separate and equal station to which the laws of nature and of nature's God entitle them, a decent respect to the opinions of mankind requires that they should declare the causes which impel them to the separation. We hold these truths to be self-evident, that all men are created equal; that they are endowed by their Creator with certain unalienable rights; that among these, are life, liberty, and the pursuit of happiness. That, to secure these rights, governments are instituted among men, deriving their just powers from the consent of the governed; that, whenever any form of government becomes destructive of these ends, it is the right of the people to alter or to abolish it, and to institute a new government, laying its foundation on such principles, and organizing its powers in such form, as to them shall seem most likely to effect their safety and happiness. Prudence, indeed, will dictate that governments long established, should not be changed for light and transient causes; and, accordingly, all experience

Lower case a to z, 16½ ems

ABCDEFGHIJKLMN OPQRSTUVWXYZ

1234567890

5¼ POINT SELF SPACING NO 19½ °

Unit of measure, 12 to Pica

WHEN, in the course of human events, it becomes necessary for one people to dissolve the political bands which have connected them with another, and to assume, among the powers of the earth, the separate and equal station to which the laws of nature and of nature's God entitle them, a decent respect to the opinions of mankind requires that they should declare the causes which impel them to the separation. We hold these truths to be self-evident, that all men are created equal; that they are endowed by their Creator with certain unalienable rights; that among these, are life, liberty, and the pursuit of happiness. That, to secure these rights, governments are instituted among men, deriving their just powers from the consent of the governed; that, whenever any form of government becomes destructive of these ends, it is the right of the people to alter or to abolish it, and to institute a new government, laying its foundation on such principles, and organizing its powers in such form, as to them shall seem most likely to effect their safety and happiness. Prudence, indeed, will dictate that governments long established, should not be changed for light and tran-

Lower case a to z, 16½ ems

ABCDEFGHIJKLMN OPQRSTUVWXYZ

1234567890

5¼ POINT NO 56 °

WHEN, in the course of human events, it becomes necessary for one people to dissolve the political bands which have connected them with another, and to assume, among the powers of the earth, the separate and equal station to which the laws of nature and of nature's God entitle them, a decent respect to the opinions of mankind requires that they should declare the causes which impel them to the separation. We hold these truths to be self-evident, that all men are created equal; that they are endowed by their Creator with certain unalienable rights; that among these, are life, liberty, and the pursuit of happiness. That, to secure these rights, governments are instituted among men, deriving their just powers from the consent of the governed; that, whenever any form of government becomes destructive of these ends, it is the right of the people to alter or to abolish it, and to institute a new government, laying its foundation on such principles, and organizing its powers in such form, as to them shall seem most likely to effect their safety and happiness. Prudence, indeed, will dictate that governments long established, should not be changed for light and transient

Lower case a to z, 17½ ems

ABCDEFGHIJKLMN OPQRSTUVWXYZ

1234567890

6 POINT NO 116 °

WHEN, in the course of human events, it becomes necessary for one people to dissolve the political bands which have connected them with another, and to assume, among the powers of the earth, the separate and equal station to which the laws of nature and of nature's God entitle them, a decent respect to the opinions of mankind requires that they should declare the causes which impel them to the separation. We hold these truths to be self-evident, that all men are created equal; that they are endowed by their Creator with certain unalienable rights; that among these, are life, liberty, and the pursuit of happiness. That, to secure these rights, governments are instituted among men, deriving their just powers from the consent of the governed; that, whenever any form of government becomes destructive of these ends, it is the right of the people to alter or to abolish it, and to institute a new government, laying its foundations on such principles, and organizing its powers in such form, as to them shall seem most likely to effect their safety and happiness. Prudence, indeed, will dictate that

Lower case a to z, 15½ ems

ABCDEFGHIJKLMN OPQRSTUVWXYZ

1234567890

6 POINT No 47 ¹⁸

WHEN, in the course of human events, it becomes necessary for one people to dissolve the political bands which have connected them with another, and to assume, among the powers of the earth, the separate and equal station to which the laws of nature and of nature's God entitle them, a decent respect to the opinions of mankind requires that they should declare the causes which impel them to the separation. We hold these truths to be self-evident, that all men are created equal; that they are endowed by their Creator with certain unalienable rights; that among these, are life, liberty, and the pursuit of happiness. That, to secure these rights, governments are instituted among men, deriving their just powers from the consent of the governed; that, whenever any form of government becomes destructive of these ends, it is the right of the people to alter or to abolish it, and to institute a new government, laying its foundation on such principles, and organizing its powers in such form, as to them shall seem most likely to effect their safety and happiness. *Prudence, indeed, will dictate that gov-*

Lower case a to z, 15½ ems

ABCDEFGHIJKLMNPOQRSTUVWXYZ
1234567890

6 POINT SELF SPACING No 20½ ¹⁸

Unit of measure, 12 to Pica

WHEN, in the course of human events, it becomes necessary for one people to dissolve the political bands which have connected them with another, and to assume, among the powers of the earth, the separate and equal station to which the laws of nature and of nature's God entitle them, a decent respect to the opinions of mankind requires that they should declare the causes which impel them to the separation. We hold these truths to be self-evident, that all men are created equal; that they are endowed by their Creator with certain unalienable rights; that among these, are life, liberty, and the pursuit of happiness. That, to secure these rights, governments are instituted among men, deriving their just powers from the consent of the governed; that, whenever any form of government becomes destructive of these ends, it is the right of the people to alter or to abolish it, and to institute a new government, laying its foundation on such principles, and organizing its powers in such form, as to them shall seem most likely to effect their safety and happiness. *Prudence, indeed, will*

Lower case a to z, 15½ ems

ABCDEFGHIJKLMNPOQRSTUVWXYZ
1234567890

6 POINT No 49 ¹⁸

WHEN, in the course of human events, it becomes necessary for one people to dissolve the political bands which have connected them with another, and to assume, among the powers of the earth, the separate and equal station to which the laws of nature and of nature's God entitle them, a decent respect to the opinions of mankind requires that they should declare the causes which impel them to the separation. We hold these truths to be self-evident, that all men are created equal; that they are endowed by their Creator with certain unalienable rights; that among these, are life, liberty, and the pursuit of happiness. That, to secure these rights, governments are instituted among men, deriving their just powers from the consent of the governed; that, whenever any form of government becomes destructive of these ends, it is the right of the people to alter or to abolish it, and to institute a new government, laying its foundation on such principles, and organizing its powers in such form, as to them shall seem most likely to effect their safety and happiness. *Prudence,*

Lower case a to z, 16 ems

ABCDEFGHIJKLMNPOQRSTUVWXYZ
1234567890

6 POINT No 50 ¹⁸

WHEN, in the course of human events, it becomes necessary for one people to dissolve the political bands which have connected them with another, and to assume, among the powers of the earth, the separate and equal station to which the laws of nature and of nature's God entitle them, a decent respect to the opinions of mankind requires that they should declare the causes which impel them to the separation. We hold these truths to be self-evident, that all men are created equal; that they are endowed by their Creator with certain unalienable rights; that among these, are life, liberty, and the pursuit of happiness. That, to secure these rights, governments are instituted among men, deriving their just powers from the consent of the governed; that, whenever any form of government becomes destructive of these ends, it is the right of the people to alter or to abolish it, and to institute a new government, laying its foundation on such principles, and organizing its powers in such form, as to them shall seem most likely to effect their safety and happiness.

Lower case a to z, 15½ ems

ABCDEFGHIJKLMNPOQRSTUVWXYZ
1234567890

6 POINT NO 62

WHEN, in the course of human events, it becomes necessary for one people to dissolve the political bands which have connected them with another, and to assume, among the powers of the earth, the separate and equal station to which the laws of nature and of nature's God entitle them, a decent respect to the opinions of mankind requires that they should declare the causes which impel them to the separation. We hold these truths to be self-evident, that all men are created equal; that they are endowed by their Creator with certain unalienable rights; that among these, are life, liberty, and the pursuit of happiness. That, to secure these rights, governments are instituted among men, deriving their just powers from the consent of the governed; that, whenever any form of government becomes destructive of these ends, it is the right of the people to alter or to abolish it, and to institute a new government, laying its foundation on such principles, and organizing its powers in such form, as to them shall seem most likely to effect their safety and happiness.

Lower case a to z, 16½ ems

ABCDEFGHIJKLMN OPQRSTUVWXYZ
1234567890

6 POINT NO 45

WHEN, in the course of human events, it becomes necessary for one people to dissolve the political bands which have connected them with another, and to assume, among the powers of the earth, the separate and equal station to which the laws of nature and of nature's God entitle them, a decent respect to the opinions of mankind requires that they should declare the causes which impel them to the separation. We hold these truths to be self-evident, that all men are created equal; that they are endowed by their Creator with certain unalienable rights; that among these, are life, liberty, and the pursuit of happiness. That, to secure these rights, governments are instituted among men, deriving their just powers from the consent of the governed; that, whenever any form of government becomes destructive of these ends, it is the right of the people to alter or to abolish it, and to institute a new government, laying its foundation on such principles, and organizing its powers in such form, as to them shall seem most likely to effect their safety and happiness. Pru-

Lower case a to z, 16½ ems

ABCDEFGHIJKLMN OPQRSTUVWXYZ
1234567890

6 POINT NO 57

WHEN, in the course of human events, it becomes necessary for one people to dissolve the political bands which have connected them with another, and to assume, among the powers of the earth, the separate and equal station to which the laws of nature and of nature's God entitle them, a decent respect to the opinions of mankind requires that they should declare the causes which impel them to the separation. We hold these truths to be self-evident, that all men are created equal; that they are endowed by their Creator with certain unalienable rights; that among these, are life, liberty, and the pursuit of happiness. That, to secure these rights, governments are instituted among men, deriving their just powers from the consent of the governed; that, whenever any form of government becomes destructive of these ends, it is the right of the people to alter or to abolish it, and to institute a new government, laying its foundation on such principles, and organizing its powers in such form, as to them shall seem most likely to effect their safety

Lower case a to z, 15¾ ems

ABCDEFGHIJKLMN OPQRSTUVWXYZ
1234567890

6 POINT NO 46

WHEN, in the course of human events, it becomes necessary for one people to dissolve the political bands which have connected them with another, and to assume, among the powers of the earth, the separate and equal station to which the laws of nature and of nature's God entitle them, a decent respect to the opinions of mankind requires that they should declare the causes which impel them to the separation. We hold these truths to be self-evident, that all men are created equal; that they are endowed by their Creator with certain unalienable rights; that among these, are life, liberty, and the pursuit of happiness. That, to secure these rights, governments are instituted among men, deriving their just powers from the consent of the governed; that, whenever any form of government becomes destructive of these ends, it is the right of the people to alter or to abolish it, and to institute a new government, laying its foundation on such principles, and organizing its powers in such form, as to them shall seem most likely to effect their safety

Lower case a to z, 16½ ems

ABCDEFGHIJKLMN OPQRSTUVWXYZ
1234567890

6 POINT NO 61 °

WHEN, in the course of human events, it becomes necessary for one people to dissolve the political bands which have connected them with another, and to assume, among the powers of the earth, the separate and equal station to which the laws of nature and of nature's God entitle them, a decent respect to the opinions of mankind requires that they should declare the causes which impel them to the separation. We hold these truths to be self-evident, that all men are created equal; that they are endowed by their Creator with certain unalienable rights; that among these, are life, liberty, and the pursuit of happiness. That, to secure these rights, governments are instituted among men, deriving their just powers from the consent of the governed; that, whenever any form of government becomes destructive of these ends, it is the right of the people to alter or to abolish it, and to institute a new government, laying its foundation on such principles, and organizing its powers in such form, as to them shall seem most

Lower case a to z, 16½ ems

ABCDEFGHIJKLMN OPQRSTUVWXYZ

1234567890

6 POINT NO 58 °

WHEN, in the course of human events, it becomes necessary for one people to dissolve the political bands which have connected them with another, and to assume, among the powers of the earth, the separate and equal station to which the laws of nature and of nature's God entitle them, a decent respect to the opinions of mankind requires that they should declare the causes which impel them to the separation. We hold these truths to be self-evident, that all men are created equal; that they are endowed by their Creator with certain unalienable rights; that among these, are life, liberty, and the pursuit of happiness. That, to secure these rights, governments are instituted among men, deriving their just powers from the consent of the governed; that, whenever any form of government becomes destructive of these ends, it is the right of the people to alter or to abolish it, and to institute a new government, laying its foundation on such principles, and organizing its powers in such form, as to them shall seem most likely to

Lower case a to z, 16½ ems

ABCDEFGHIJKLMN OPQRSTUVWXYZ

1234567890

6 POINT SELF SPACING NO 3½ °

Unit of measure, 11 to Pica

WHEN, in the course of human events, it becomes necessary for one people to dissolve the political bands which have connected them with another, and to assume, among the powers of the earth, the separate and equal station to which the laws of nature and of nature's God entitle them, a decent respect to the opinions of mankind requires that they should declare the causes which impel them to the separation. We hold these truths to be self-evident, that all men are created equal; that they are endowed by their Creator with certain unalienable rights; that among these, are life, liberty, and the pursuit of happiness. That, to secure these rights, governments are instituted among men, deriving their just powers from the consent of the governed; that, whenever any form of government becomes destructive of these ends, it is the right of the people to alter or to abolish it, and to institute a new government, laying its foundation on such principles, and organizing its powers in such form, as

Lower case a to z, 17 ems

ABCDEFGHIJKLMN OPQRSTUVWXYZ

1234567890

6 POINT NO 56 °

WHEN, in the course of human events, it becomes necessary for one people to dissolve the political bands which have connected them with another, and to assume, among the powers of the earth, the separate and equal station to which the laws of nature and of nature's God entitle them, a decent respect to the opinions of mankind requires that they should declare the causes which impel them to the separation. We hold these truths to be self-evident, that all men are created equal; that they are endowed by their Creator with certain unalienable rights; that among these, are life, liberty, and the pursuit of happiness. That, to secure these rights, governments are instituted among men, deriving their just powers from the consent of the governed; that, whenever any form of government becomes destructive of these ends, it is the right of the people to alter or to abolish it, and to institute a new government, laying its foundation on such principles, and organizing its powers in such

Lower case a to z, 18 ems

ABCDEFGHIJKLMN OPQRSTUVWXYZ

1234567890

7 POINT NO 47 ¹⁵

WHEN, in the course of human events, it becomes necessary for one people to dissolve the political bands which have connected them with another, and to assume, among the powers of the earth, the separate and equal station to which the laws of nature and of nature's God entitle them, a decent respect to the opinions of mankind requires that they should declare the causes which impel them to the separation. We hold these truths to be self-evident, that all men are created equal; that they are endowed by their Creator with certain unalienable rights; that among these, are life, liberty, and the pursuit of happiness. That, to secure these rights, governments are instituted among men, deriving their just powers from the consent of the governed; that, whenever any form of government becomes destructive of these ends, it is the right of the people to alter or

Lower case a to z, 14½ ems

ABCDEFGHIJKLMN OPQRSTUVWXYZ
1234567890

7 POINT SELF SPACING NO 23½ ³

Unit of measure, 11 to Pica

WHEN, in the course of human events, it becomes necessary for one people to dissolve the political bands which have connected them with another, and to assume, among the powers of the earth, the separate and equal station to which the laws of nature and of nature's God entitle them, a decent respect to the opinions of mankind requires that they should declare the causes which impel them to the separation. We hold these truths to be self-evident, that all men are created equal; that they are endowed by their Creator with certain unalienable rights; that among these, are life, liberty, and the pursuit of happiness. That, to secure these rights, governments are instituted among men, deriving their just powers from the consent of the governed; that, whenever any form of government becomes destructive of these ends, it is the right of

Lower case a to z, 14½ ems

ABCDEFGHIJKLMN OPQRSTUVWXYZ
1234567890

7 POINT NO 60 ²

WHEN, in the course of human events, it becomes necessary for one people to dissolve the political bands which have connected them with another, and to assume, among the powers of the earth, the separate and equal station to which the laws of nature and of nature's God entitle them, a decent respect to the opinions of mankind requires that they should declare the causes which impel them to the separation. We hold these truths to be self-evident, that all men are created equal; that they are endowed by their Creator with certain unalienable rights; that among these, are life, liberty, and the pursuit of happiness. That, to secure these rights, governments are instituted among men, deriving their just powers from the consent of the governed; that, whenever any form of government becomes destructive of these ends, it is the

Lower case a to z, 15 1-5 ems

ABCDEFGHIJKLMN OPQRSTUVWXYZ
1234567890

7 POINT NO 62 ²

WHEN, in the course of human events, it becomes necessary for one people to dissolve the political bands which have connected them with another, and to assume, among the powers of the earth, the separate and equal station to which the laws of nature and of nature's God entitle them, a decent respect to the opinions of mankind requires that they should declare the causes which impel them to the separation. We hold these truths to be self-evident, that all men are created equal; that they are endowed by their Creator with certain unalienable rights; that among these, are life, liberty, and the pursuit of happiness. That, to secure these rights, governments are instituted among men, deriving their just powers from the consent of the governed; that, whenever any form of government becomes destructive of these ends, it is the

Lower case a to z, 14½ ems

ABCDEFGHIJKLMN OPQRSTUVWXYZ
1234567890

7 POINT No 50 ¹⁵

WHEN, in the course of human events, it becomes necessary for one people to dissolve the political bands which have connected them with another, and to assume, among the powers of the earth, the separate and equal station to which the laws of nature and of nature's God entitle them, a decent respect to the opinions of mankind requires that they should declare the causes which impel them to the separation. We hold these truths to be self-evident, that all men are created equal; that they are endowed by their Creator with certain unalienable rights; that among these, are life, liberty, and the pursuit of happiness. That, to secure these rights, governments are instituted among men, deriving their just powers from the consent of the governed; *that, whenever any form of government becomes destructive of these ends, it*

Lower case a to z, 14 $\frac{3}{4}$ ems

ABCDEFGHIJKLMN OPQRSTUVWXYZ
1234567890

7 POINT No 57 ⁰

WHEN, in the course of human events, it becomes necessary for one people to dissolve the political bands which have connected them with another, and to assume, among the powers of the earth, the separate and equal station to which the laws of nature and of nature's God entitle them, a decent respect to the opinions of mankind requires that they should declare the causes which impel them to the separation. We hold these truths to be self-evident, that all men are created equal; that they are endowed by their Creator with certain unalienable rights; that among these, are life, liberty, and the pursuit of happiness. That, to secure these rights, governments are instituted among men, deriving their just powers from the consent of the governed; *that, whenever any form of government becomes destructive of these ends,*

Lower case a to z, 14 $\frac{3}{4}$ ems

ABCDEFGHIJKLMN OPQRSTUVWXYZ
1234567890

7 POINT No 49 ¹⁴

WHEN, in the course of human events, it becomes necessary for one people to dissolve the political bands which have connected them with another, and to assume, among the powers of the earth, the separate and equal station to which the laws of nature and of nature's God entitle them, a decent respect to the opinions of mankind requires that they should declare the causes which impel them to the separation. We hold these truths to be self-evident, that all men are created equal; that they are endowed by their Creator with certain unalienable rights; that among these, are life, liberty, and the pursuit of happiness. That, to secure these rights, governments are instituted among men, deriving their just powers from the consent of the governed; *that, whenever any form of government becomes destructive*

Lower case a to z, 15 $\frac{1}{2}$ ems

ABCDEFGHIJKLMN OPQRSTUVWXYZ
1234567890

7 POINT No 45 ¹⁵

WHEN, in the course of human events, it becomes necessary for one people to dissolve the political bands which have connected them with another, and to assume, among the powers of the earth, the separate and equal station to which the laws of nature and of nature's God entitle them, a decent respect to the opinions of mankind requires that they should declare the causes which impel them to the separation. We hold these truths to be self-evident, that all men are created equal; that they are endowed by their Creator with certain unalienable rights; that among these, are life, liberty, and the pursuit of happiness. That, to secure these rights, governments are instituted among men, deriving their just powers from the consent of the governed; *that, whenever any form of government becomes*

Lower case a to z, 15 $\frac{1}{2}$ ems

ABCDEFGHIJKLMN OPQRSTUVWXYZ
1234567890

7 POINT NO 58 °

WHEN, in the course of human events, it becomes necessary for one people to dissolve the political bands which have connected them with another, and to assume, among the powers of the earth, the separate and equal station to which the laws of nature and of nature's God entitle them, a decent respect to the opinions of mankind requires that they should declare the causes which impel them to the separation. We hold these truths to be self-evident, that all men are created equal; that they are endowed by their Creator with certain unalienable rights; that among these, are life, liberty, and the pursuit of happiness. That, to secure these rights, governments are instituted among men, deriving their just powers from the consent of the governed: that, whenever any form of government becomes destruc-

Lower case a to z, 15½ ems

ABCDEFGHIJKLMN OPQRSTUVWXYZ
1234567890

7 POINT NO 61 °

WHEN, in the course of human events, it becomes necessary for one people to dissolve the political bands which have connected them with another, and to assume, among the powers of the earth, the separate and equal station to which the laws of nature and of nature's God entitle them, a decent respect to the opinions of mankind requires that they should declare the causes which impel them to the separation. We hold these truths to be self-evident, that all men are created equal; that they are endowed by their Creator with certain unalienable rights; that among these, are life, liberty, and the pursuit of happiness. That, to secure these rights, governments are instituted among men, deriving their just powers from the consent of the governed; that, whenever any form of government

Lower case a to z, 15½ ems

ABCDEFGHIJKLMN OPQRSTUVWXYZ
1234567890

7 POINT NO 46 °

WHEN, in the course of human events, it becomes necessary for one people to dissolve the political bands which have connected them with another, and to assume, among the powers of the earth, the separate and equal station to which the laws of nature and of nature's God entitle them, a decent respect to the opinions of mankind requires that they should declare the causes which impel them to the separation. We hold these truths to be self-evident, that all men are created equal; that they are endowed by their Creator with certain unalienable rights; that among these, are life, liberty, and the pursuit of happiness. That, to secure these rights, governments are instituted among men, deriving their just powers from the consent of the governed; that, whenever any form of govern-

Lower case a to z, 16 ems

ABCDEFGHIJKLMN OPQRSTUVWXYZ
1234567890

7 POINT SELF SPACING NO 38½ °

Unit of measure, 10 to Pica

WHEN, in the course of human events, it becomes necessary for one people to dissolve the political bands which have connected them with another, and to assume, among the powers of the earth, the separate and equal station to which the laws of nature and of nature's God entitle them, a decent respect to the opinions of mankind requires that they should declare the causes which impel them to the separation. We hold these truths to be self-evident, that all men are created equal; that they are endowed by their Creator with certain unalienable rights; that among these, are life, liberty, and the pursuit of happiness. That, to secure these rights, governments are instituted among men, deriving their just powers from the consent of the governed: that, whenever

Lower case a to z, 16 ems

ABCDEFGHIJKLMN OPQRSTUVWXYZ
1234567890

7 POINT No 56

WHEN, in the course of human events, it becomes necessary for one people to dissolve the political bands which have connected them with another, and to assume, among the powers of the earth, the separate and equal station to which the laws of nature and of nature's God entitle them, a decent respect to the opinions of mankind requires that they should declare the causes which impel them to the separation. We hold these truths to be self-evident, that all men are created equal; that they are endowed by their Creator with certain unalienable rights; that among these, are life, liberty, and the pursuit of happiness. That, to secure these rights, governments are instituted among men, deriving their just powers from the consent of the governed;

Lower case a to z, 17 ems

ABCDEFGHIJKLMN OPQRSTUVWXYZ
1234567890

8 POINT CENTURY ROMAN

WHEN, in the course of human events, it becomes necessary for one people to dissolve the political bands which have connected them with another, and to assume, among the powers of the earth, the separate and equal station to which the laws of nature and of nature's God entitle them, a decent respect to the opinions of mankind requires that they should declare the causes which impel them to the separation. We hold these truths to be self-evident, that all men are created equal; that they are endowed by their Creator with certain unalienable rights; that among these, are life, liberty, and the pursuit of happiness. That, to secure these rights, governments are instituted among men, deriving their

Lower case a to z, 12 ems

ABCDEFGHIJKLMN OPQRSTUVWXYZ
1234567890

8 POINT No 47

WHEN, in the course of human events, it becomes necessary for one people to dissolve the political bands which have connected them with another, and to assume, among the powers of the earth, the separate and equal station to which the laws of nature and of nature's God entitle them, a decent respect to the opinions of mankind requires that they should declare the causes which impel them to the separation. We hold these truths to be self-evident, that all men are created equal; that they are endowed by their Creator with certain unalienable rights; that among these, are life, liberty, and the pursuit of happiness. That, to secure these

Lower case a to z, 13½ ems

ABCDEFGHIJKLMN OPQRSTUVWXYZ
1234567890

8 POINT SELF SPACING NO 18½

Unit of measure, 10 to Pica

WHEN, in the course of human events, it becomes necessary for one people to dissolve the political bands which have connected them with another, and to assume, among the powers of the earth, the separate and equal station to which the laws of nature and of nature's God entitle them, a decent respect to the opinions of mankind requires that they should declare the causes which impel them to the separation. We hold these truths to be self-evident, that all men are created equal; that they are endowed by their Creator with certain unalienable rights; that among these, are life, liberty, and the pursuit of happiness. That,

Lower case a to z, 14½ ems

ABCDEFGHIJKLMN OPQRSTUVWXYZ
1234567890

8 POINT NO 45 °

WHEN, in the course of human events, it becomes necessary for one people to dissolve the political bands which have connected them with another, and to assume, among the powers of the earth, the separate and equal station to which the laws of nature and of nature's God entitle them, a decent respect to the opinions of mankind requires that they should declare the causes which impel them to the separation. We hold these truths to be self-evident, that all men are created equal; that they are endowed by their Creator with certain unalienable rights; *that among these, are life, liberty, and the pursuit of happiness. That, to*

Lower case a to z, 14½ ems

ABCDEFGHIJKLMNOPQRSTUVWXYZ

1234567890

8 POINT NO 57 °

WHEN, in the course of human events, it becomes necessary for one people to dissolve the political bands which have connected them with another, and to assume, among the powers of the earth, the separate and equal station to which the laws of nature and of nature's God entitle them, a decent respect to the opinions of mankind requires that they should declare the causes which impel them to the separation. We hold these truths to be self-evident, that all men are created equal; that they are endowed by their Creator with certain unalienable rights; *that among these, are life, liberty, and the pursuit of*

Lower case a to z, 14 ems

ABCDEFGHIJKLMNOPQRSTUVWXYZ

1234567890

8 POINT NO 50 °

WHEN, in the course of human events, it becomes necessary for one people to dissolve the political bands which have connected them with another, and to assume, among the powers of the earth, the separate and equal station to which the laws of nature and of nature's God entitle them, a decent respect to the opinions of mankind requires that they should declare the causes which impel them to the separation. We hold these truths to be self-evident, that all men are created equal; that they are endowed by their Creator with certain unalienable rights; *that among these, are life, liberty, and the pursuit of happi-*

Lower case a to z, 14 ems

ABCDEFGHIJKLMNOPQRSTUVWXYZ

1234567890

8 POINT NO 61 °

WHEN, in the course of human events, it becomes necessary for one people to dissolve the political bands which have connected them with another, and to assume, among the powers of the earth, the separate and equal station to which the laws of nature and of nature's God entitle them, a decent respect to the opinions of mankind requires that they should declare the causes which impel them to the separation. We hold these truths to be self-evident, that all men are created equal; that they are endowed by their Creator with certain unalienable rights; *that among these, are life, liberty, and the pursuit of happiness.*

Lower case a to z, 14½ ems

ABCDEFGHIJKLMNOPQRSTUVWXYZ

1234567890

8 POINT NO 49 °

WHEN, in the course of human events, it becomes necessary for one people to dissolve the political bands which have connected them with another, and to assume, among the powers of the earth, the separate and equal station to which the laws of nature and of nature's God entitle them, a decent respect to the opinions of mankind requires that they should declare the causes which impel them to the separation. We hold these truths to be self-evident, that all men are created equal; that they are endowed by their Creator with certain unalienable rights; that among these, are life, liberty, and the pursuit of happiness.

Lower case a to z, 14½ ems

ABCDEFGHIJKLMN OPQRSTUVWXYZ

1234567890

8 POINT NO 62 °

WHEN, in the course of human events, it becomes necessary for one people to dissolve the political bands which have connected them with another, and to assume, among the powers of the earth, the separate and equal station to which the laws of nature and of nature's God entitle them, a decent respect to the opinions of mankind requires that they should declare the causes which impel them to the separation. We hold these truths to be self-evident, that all men are created equal; that they are endowed by their Creator with certain unalienable rights; that among these, are life, liberty and

Lower case a to z, 14¾ ems

ABCDEFGHIJKLMN OPQRSTUVWXYZ

1234567890

8 POINT NO 58 °

WHEN, in the course of human events, it becomes necessary for one people to dissolve the political bands which have connected them with another, and to assume, among the powers of the earth, the separate and equal station to which the laws of nature and of nature's God entitle them, a decent respect to the opinions of mankind requires that they should declare the causes which impel them to the separation. We hold these truths to be self-evident, that all men are created equal; that they are endowed by their Creator with certain unalienable rights; that among these, are life, liberty,

Lower case a to z, 14½ ems

ABCDEFGHIJKLMN OPQRSTUVWXYZ

1234567890

8 POINT NO 60 °

WHEN, in the course of human events, it becomes necessary for one people to dissolve the political bands which have connected them with another, and to assume, among the powers of the earth, the separate and equal station to which the laws of nature and of nature's God entitle them, a decent respect to the opinions of mankind requires that they should declare the causes which impel them to the separation. We hold these truths to be self-evident, that all men are created equal; that they are endowed by their Creator with certain unalienable rights; that among these, are life, liberty,

Lower case a to z, 15 ems

ABCDEFGHIJKLMN OPQRSTUVWXYZ

1234567890

8 POINT No 46

WHEN, in the course of human events, it becomes necessary for one people to dissolve the political bands which have connected them with another, and to assume, among the powers of the earth, the separate and equal station to which the laws of nature and of nature's God entitle them, a decent respect to the opinions of mankind requires that they should declare the causes which impel them to the separation. We hold these truths to be self-evident, that all men are created equal; that they are endowed by their *Creator with certain unalienable rights; that among these, are life,*

Lower case a to z, 15¼ ems

ABCDEFGHIJKLMN OPQRSTUVWXYZ
1234567890

8 POINT No 56

WHEN, in the course of human events, it becomes necessary for one people to dissolve the political bands which have connected them with another, and to assume, among the powers of the earth, the separate and equal station to which the laws of nature and of nature's God entitle them, a decent respect to the opinions of mankind requires that they should declare the causes which impel them to the separation. We hold these truths to be self-evident, that all men are created equal; that they are *endowed by their Creator with certain unalienable rights; that*

Lower case a to z, 15¼ ems

ABCDEFGHIJKLMN OPQRSTUVWXYZ
1234567890

8 POINT SELF SPACING NO 48½

Unit of measure. 9 to Pica

WHEN, in the course of human events, it becomes necessary for one people to dissolve the political bands which have connected them with another, and to assume, among the powers of the earth, the separate and equal station to which the laws of nature and of nature's God entitle them, a decent respect to the opinions of mankind requires that they should declare the causes which impel them to the separation. We hold these truths to be self-evident, that all men are created equal; that *they are endowed by their Creator with certain unalienable*

Lower case a to z, 15½ ems

ABCDEFGHIJKLMN OPQRSTUVWXYZ
1234567890

9 POINT CENTURY ROMAN

WHEN, in the course of human events, it becomes necessary for one people to dissolve the political bands which have connected them with another, and to assume among the powers of the earth, the separate and equal station to which the laws of nature and of nature's God entitle them, a decent respect to the opinions of mankind requires that they should declare the causes which impel them to the separation. We hold these truths to be self-evident, that all men are created equal; that they *are endowed by their Creator with certain unalienable rights; that among*

Lower case a to z, 12¼ ems

ABCDEFGHIJKLMN OPQRSTUVWXYZ
1234567890

9 POINT No 47 ¹⁵

WHEN, in the course of human events, it becomes necessary for one people to dissolve the political bands which have connected them with another, and to assume, among the powers of the earth, the separate and equal station to which the laws of nature and of nature's God entitle them, a decent respect to the opinions of mankind requires that they should declare the causes which impel them to the separation. We hold these truths to be self-evident, *that all men are created equal; that they are endowed by their Creator*

Lower case a to z, 13 ems

ABCDEFGHIJKLMNOPQRSTUVWXYZ
1234567890

9 POINT No 57 ⁰

WHEN, in the course of human events, it becomes necessary for one people to dissolve the political bands which have connected them with another, and to assume, among the powers of the earth, the separate and equal station to which the laws of nature and of nature's God entitle them, a decent respect to the opinions of mankind requires that they should declare the causes which impel them to the separation. We hold these truths to be self-evident, *that all men are created equal; that they are endowed by their*

Lower case a to z, 13½ ems

ABCDEFGHIJKLMNOPQRSTUVWXYZ
1234567890

9 POINT No 58 ⁰

WHEN, in the course of human events, it becomes necessary for one people to dissolve the political bands which have connected them with another, and to assume, among the powers of the earth, the separate and equal station to which the laws of nature and of nature's God entitle them, a decent respect to the opinions of mankind requires that they should declare the causes which impel them to the separation. We hold these truths to be self-evident, *that all men are created equal; that they are endowed by their*

Lower case a to z, 13¼ ems

ABCDEFGHIJKLMNOPQRSTUVWXYZ
1234567890

9 POINT No 45 ¹⁵

WHEN, in the course of human events, it becomes necessary for one people to dissolve the political bands which have connected them with another, and to assume, among the powers of the earth, the separate and equal station to which the laws of nature and of nature's God entitle them, a decent respect to the opinions of mankind requires that they should declare the causes which impel them to the separation. We hold these truths to be self-evident, *that all men are created equal; that they are endowed by*

Lower case a to z, 13½ ems

ABCDEFGHIJKLMNOPQRSTUVWXYZ
1234567890

9 POINT SELF SPACING NO 32½

Unit of measure, 9 to Pica

WHEN, in the course of human events, it becomes necessary for one people to dissolve the political bands which have connected them with another, and to assume, among the powers of the earth, the separate and equal station to which the laws of nature and of nature's God entitle them, a decent respect to the opinions of mankind requires that they should declare the causes which impel them to the separation. We hold these truths to be self-evident, that all men are created equal; that they are endowed

Lower case a to z, 13½ ems

ABCDEFGHIJKLMNOPQRSTUVWXYZ
1234567890

9 POINT NO 60

WHEN, in the course of human events, it becomes necessary for one people to dissolve the political bands which have connected them with another, and to assume, among the powers of the earth, the separate and equal station to which the laws of nature and of nature's God entitle them, a decent respect to the opinions of mankind requires that they should declare the causes which impel them to the separation. We hold these truths to be self-evident, that all men are created equal; that they are endowed

Lower case a to z, 13.4-5 ems

ABCDEFGHIJKLMNOPQRSTUVWXYZ
1234567890

9 POINT NO 50

WHEN, in the course of human events, it becomes necessary for one people to dissolve the political bands which have connected them with another, and to assume, among the powers of the earth, the separate and equal station to which the laws of nature and of nature's God entitle them, a decent respect to the opinions of mankind requires that they should declare the causes which impel them to the separation. We hold these truths to be self-evident, that all men are created equal; that they

Lower case a to z, 14 ems

ABCDEFGHIJKLMNOPQRSTUVWXYZ
1234567890

9 POINT NO 61

WHEN, in the course of human events, it becomes necessary for one people to dissolve the political bands which have connected them with another, and to assume, among the powers of the earth, the separate and equal station to which the laws of nature and of nature's God entitle them, a decent respect to the opinions of mankind requires that they should declare the causes which impel them to the separation. We hold these truths to be self-evident, that all men are created equal; that

Lower case a to z, 15½ ems

ABCDEFGHIJKLMNOPQRSTUVWXYZ
1234567890

9 POINT No 56

WHEN, in the course of human events, it becomes necessary for one people to dissolve the political bands which have connected them with another, and to assume, among the powers of the earth, the separate and equal station to which the laws of nature and of nature's God entitle them, a decent respect to the opinions of mankind requires that they should declare the causes which impel them to the separation. We hold *these truths to be self-evident, that all men are created equal;*

Lower case a to z, 15 ems

ABCDEFGHIJKLMNOPQRSTUVWXYZ

1234567890

9 POINT No 46

WHEN, in the course of human events, it becomes necessary for one people to dissolve the political bands which have connected them with another, and to assume, among the powers of the earth, the separate and equal station to which the laws of nature and of nature's God entitle them, a decent respect to the opinions of mankind requires that they should declare the causes which impel them to the separation. We hold these truths to be self-evident, that all men are created

Lower case a to z, 15 ems

ABCDEFGHIJKLMNOPQRSTUVWXYZ

1234567890

10 POINT CENTURY ROMAN

WHEN, in the course of human events, it becomes necessary for one people to dissolve the political bands which have connected them with another, and to assume, among the powers of the earth, the separate and equal station to which the laws of nature and of nature's God entitle them, a decent respect to the opinions of mankind requires that they should declare the causes which impel them to the separation. *We hold these truths to be self-evident,*

Lower case a to z, 12 ems

ABCDEFGHIJKLMNOPQRSTUVWXYZ

1234567890

10 POINT No 47

WHEN, in the course of human events, it becomes necessary for one people to dissolve the political bands which have connected them with another, and to assume, among the powers of the earth, the separate and equal station to which the laws of nature and of nature's God entitle them, a decent respect to the opinions of mankind requires that they should declare *the causes which impel them to the separation. We hold these*

Lower case a to z, 14 ems

ABCDEFGHIJKLMNOPQRSTUVWXYZ

1234567890

10 POINT NO 57 °

WHEN, in the course of human events, it becomes necessary for one people to dissolve the political bands which have connected them with another, and to assume, among the powers of the earth, the separate and equal station to which the laws of nature and of nature's God entitle them, a decent respect to the opinions of mankind requires that they should *declare the causes which impel them to the separation.* We

Lower case a to z, 13¼ ems

ABCDEFGHIJKLMN**OP**QRSTUVWXYZ
1234567890

10 POINT NO 58 °

WHEN, in the course of human events, it becomes necessary for one people to dissolve the political bands which have connected them with another, and to assume, among the powers of the earth, the separate and equal station to which the laws of nature and of nature's God entitle them, a decent respect to the opinions of mankind requires that *they should declare the causes which impel them to the separa-*

Lower case a to z, 13¼ ems

ABCDEFGHIJKLMN**OP**QRSTUVWXYZ
1234567890

10 POINT NO 50 °

WHEN, in the course of human events, it becomes necessary for one people to dissolve the political bands which have connected them with another, and to assume, among the powers of the earth, the separate and equal station to which the laws of nature and of nature's God entitle them, a decent respect to the opinions of mankind requires that *they should declare the causes which impel them to the sepa-*

Lower case a to z, 13¼ ems

ABCDEFGHIJKLMN**OP**QRSTUVWXYZ
1234567890

10 POINT NO 56 °

WHEN, in the course of human events, it becomes necessary for one people to dissolve the political bands which have connected them with another, and to assume, among the powers of the earth, the separate and equal station to which the laws of nature and of nature's God entitle them, a decent respect to the opinions of mankind requires *that they should declare the causes which impel them to the*

Lower case a to z, 13¼ ems

ABCDEFGHIJKLMN**OP**QRSTUVWXYZ
1234567890

10 POINT NO 45 "

WHEN, in the course of human events, it becomes necessary for one people to dissolve the political bands which have connected them with another, and to assume, among the powers of the earth, the separate and equal station to which the laws of nature and of nature's God entitle them, a decent respect to the opinions of mankind requires that they should declare the causes which impel them to the separation. We hold these truths to be self-evident, that all men are created equal; that they are endowed by their Creator with certain unalienable rights; that among these *are life, liberty, and the pursuit of happiness. That, to se-*

Lower case a to z, 13½ ems

ABCDEFGHIJKLMN^{OP}QRSTU^{VW}XYZ

1234567890

10 POINT SELF SPACING NO 17½ ' °

Unit of measure, 8 to Pica

WHEN, in the course of human events, it becomes necessary for one people to dissolve the political bands which have connected them with another, and to assume, among the powers of the earth, the separate and equal station to which the laws of nature and of nature's God entitle them, a decent respect to the opinions of mankind requires that they should declare the causes which impel them to the separation. We hold these truths to be self-evident, that all men are created equal; that they are endowed by their Creator with certain unalienable rights; *that among these, are life, liberty, and the pursuit of hap-*

Lower case a to z, 14 ems

ABCDEFGHIJKLMN^{OP}QRSTU^{VW}XYZ

1234567890

11 POINT NO 58 °

WHEN, in the course of human events, it becomes necessary for one people to dissolve the political bands which have connected them with another, and to assume, among the powers of the earth, the separate and equal station to which the laws of nature and of nature's God entitle them, a decent respect to the opinions of mankind requires that they should declare the causes which impel them to the separation. We hold these truths to be self-evident, that all men are created equal; that *they are endowed by their Creator with certain unalienable*

Lower case a to z, 13 ems

ABCDEFGHIJKLMN^{OP}QRSTU^{VW}XYZ

1234567890

11 POINT NO 47 °

WHEN, in the course of human events, it becomes necessary for one people to dissolve the political bands which have connected them with another, and to assume, among the powers of the earth, the separate and equal station to which the laws of nature and of nature's God entitle them, a decent respect to the opinions of mankind requires that they should declare the causes which impel them to the separation. We hold these truths to be self-evident, that all men are created equal; *that they are endowed by their Creator with certain un-*

Lower case a to z, 13¼ ems

ABCDEFGHIJKLMNOPQRSTUVWXYZ
1234567890

11 POINT SELF SPACING NO 21½ °

Unit of measure, 7 to Pica

WHEN, in the course of human events, it becomes necessary for one people to dissolve the political bands which have connected them with another, and to assume, among the powers of the earth, the separate and equal station to which the laws of nature and of nature's God entitle them, a decent respect to the opinions of mankind requires that they should declare the causes which impel them to the separation. We hold these truths *to be self-evident, that all men are created equal;*

Lower case a to z, 14½ ems

ABCDEFGHIJKLMNOPQRSTUVWXYZ
1234567890

12 POINT No 58 °

WHEN, in the course of human events, it becomes necessary for one people to dissolve the political bands which have connected them with another, and to assume, among the powers of the earth, the separate and equal station to which the laws of nature and of nature's God entitle them, a decent respect to the opinions of mankind requires that they should declare the causes which impel *them to the separation. We hold these truths to be self-*

Lower case a to z, 13¼ ems

ABCDEFGHIJKLMNOPQRSTUVWXYZ
1234567890

12 POINT SELF SPACING NO 31½

Unit of measure, 7 to Pica

WHEN, in the course of human events, it becomes necessary for one people to dissolve the political bands which have connected them with another, and to assume, among the powers of the earth, the separate and equal station to which the laws of nature and of nature's God entitle them, a decent respect to the opinions of mankind requires that they should declare the causes which impel *them to the separation.* *We hold these truths to*

Lower case a to z, 13½ ems

ABCDEFGHIJKLMNOPQRSTUVWXYZ
1234567890

12 POINT NO 47 "

WHEN, in the course of human events, it becomes necessary for one people to dissolve the political bands which have connected them with another, and to assume, among the powers of the earth, the separate and equal station to which the laws of nature and of nature's God entitle them, a decent respect to the opinions of mankind requires that they should declare the causes which *impel them to the separation.* *We hold these truths*

Lower case a to z, 13½ ems

ABCDEFGHIJKLMNOPQRSTUVWXYZ
1234567890

14 POINT NO 64 "

WHEN, in the course of human events, it becomes necessary for one people to dissolve the political bands which have connected them with another, and to assume, among the powers of the earth, the separate and equal station to which the laws of nature and of nature's God entitle them, a decent respect to the opinions *of mankind require that they should declare the*

ABCDEFGHIJKLMNOPQRSTUVWXYZ
1234567890

MODERN ROMANS SHOWN BY SERIES

For Modern Romans by sizes, see pages 65 to 84

SELF SPACING MODERN ROMANS

For description of Self Spacing Modern Roman and Old Style, see pages 52 and 53

5½ POINT SELF SPACING NO 19½

Unit of measure, 12 to Pica

WHEN, in the course of human events, it becomes necessary for one people to dissolve the political bands which have connected them with another, and to assume, among the powers of the earth, the separate and equal station to which the laws of nature and of nature's God entitle them, a decent respect to the opinions of mankind requires that they should declare the causes which impel them to the separation. We hold these truths to be self-evident, that all men are created equal; that they are endowed by their Creator with certain unalienable rights; that among these, are life, liberty, and the pursuit of happiness; that, to secure these rights, governments are

Lower case a to z, 16½ ems

ABCDEFGHIJKLMN O PQRSTU VWXY
1234567890

6 POINT SELF SPACING NO 20¼

Unit of measure, 12 to Pica

WHEN, in the course of human events, it becomes necessary for one people to dissolve the political bands which have connected them with another, and to assume, among the powers of the earth, the separate and equal station to which the laws of nature and of nature's God entitle them, a decent respect to the opinions of mankind requires that they should declare the causes which impel them to the separation. We hold these truths to be self-evident, that all men are created equal; that they are endowed by their Creator with certain unalienable rights; that among these, are life, liberty, and the pursuit of happiness. That, to

Lower case a to z, 15½ ems

ABCDEFGHIJKLMN O PQRSTU V W
1234567890

6 POINT SELF SPACING NO 37½

Unit of measure, 11 to Pica

WHEN, in the course of human events, it becomes necessary for one people to dissolve the political bands which have connected them with another, and to assume, among the powers of the earth, the separate and equal station to which the laws of nature and of nature's God entitle them, a decent respect to the opinions of mankind requires that they should declare the causes which impel them to the separation. We hold these truths to be self-evident, that all men are created equal; that they are endowed by their Creator with certain unalienable rights; that among these, are life, liberty, and the pursuit of happiness. That, to secure these rights, governments are instituted among men, deriving their just powers from the consent of the governed; that, whenever any form of government becomes destructive of these ends, it is the right of the people to alter or to abolish it, and to institute a new government, laying its foundation on such principles, and organizing its powers in such form, as to them shall seem most likely to effect their safety and happiness. Prudence, indeed, will dictate that governments long established, should not be changed for light and transient causes; and, accordingly, all experience hath shown,

Lower case a to z, 17 ems

ABCDEFGHIJKLMN O PQRSTU VWXY Z
1234567890

7 POINT SELF SPACING NO 23¾

Unit of measure, 11 to Pica

WHEN, in the course of human events, it becomes necessary for one people to dissolve the political bands which have connected them with another, and to assume, among the powers of the earth, the separate and equal station to which the laws of nature and of nature's God entitle them, a decent respect to the opinions of mankind requires that they should declare the causes which impel them to the separation. We hold these truths to be self-evident, that all men are created equal; that they are endowed by their Creator with certain unalienable rights; that among these, are life, liberty, and the pursuit of happiness. That, to secure these rights, governments are instituted among men, deriving their just powers from the consent of the governed; that, whenever any form of government becomes destructive of these ends, it is the right of the people to alter or to abolish it, and to institute a new government, laying its foundation on such principles, and organizing its powers in such form, as

Lower case a to z, 14½ ems

ABCDEFGHIJKLMN O PQRSTU VWXY Z
1234567890

SELF SPACING MODERN ROMANS

7 POINT SELF SPACING NO 38½

Unit of measure, 10 to Pica

WHEN, in the course of human events, it becomes necessary for one people to dissolve the political bands which have connected them with another, and to assume, among the powers of the earth, the separate and equal station to which the laws of nature and of nature's God entitle them, a decent respect to the opinions of mankind requires that they should declare the causes which impel them to the separation. We hold these truths to be self-evident, that all men are created equal; that they are endowed by their Creator with certain unalienable rights; that among these, are life, liberty, and the pursuit of happiness. That,

Lower case a to z, 16 ems

ABCDEFGHIJKLMN**OP**QRSTUVWXYZ
1234567890

8 POINT SELF SPACING NO 18½

Unit of measure, 10 to Pica

WHEN, in the course of human events, it becomes necessary for one people to dissolve the political bands which have connected them with another, and to assume, among the powers of the earth, the separate and equal station to which the laws of nature and of nature's God entitle them, a decent respect to the opinions of mankind requires that they should declare the causes which impel them to the separation. We hold these truths to be self-evident, that all men are created equal; that they are endowed by their Creator with certain unalienable rights;

Lower case a to z, 14½ ems

ABCDEFGHIJKLMN**OP**QRSTUVWXYZ
1234567890

8 POINT SELF SPACING NO 48½

Unit of measure, 9 to Pica

WHEN, in the course of human events, it becomes necessary for one people to dissolve the political bands which have connected them with another, and to assume, among the powers of the earth, the separate and equal station to which the laws of nature and of nature's God entitle them, a decent respect to the opinions of mankind requires that they should declare the causes which impel them to the separation. We hold these truths to be self-evident, that all men are created equal; that they are

Lower case a to z, 15½ ems

ABCDEFGHIJKLMN**OP**QRSTUVWXYZ
1234567890

9 POINT SELF SPACING NO 32½

Unit of measure, 9 to Pica

WHEN, in the course of human events, it becomes necessary for one people to dissolve the political bands which have connected them with another, and to assume, among the powers of the earth, the separate and equal station to which the laws of nature and of nature's God entitle them, a decent respect to the opinions of mankind requires that they should declare the causes which impel them to the separation. We hold these truths to be

Lower case a to z, 14¾ ems

ABCDEFGHIJKLMN**OP**QRSTUVWXYZ
1234567890

SELF SPACING MODERN ROMANS

10 POINT SELF SPACING NO 17½

Unit of measure, 8 to Pica

WHEN, in the course of human events, it becomes necessary for one people to dissolve the political bands which have connected them with another, and to assume, among the powers of the earth, the separate and equal station to which the laws of nature and of nature's God entitle them, a decent respect to the opinions of mankind requires that they should declare the causes which impel them to the separation. We hold these truths to be self-evident, *that all men are created equal; that they are endowed by their Creator with certain unalienable rights; that*

Lower case a to z, 14 ems

ABCDEFGHIJKLMN**OP**QRSTU**VW**XYZ
1234567890

11 POINT SELF SPACING NO 21¼

Unit of measure, 7 to Pica

WHEN, in the course of human events, it becomes necessary for one people to dissolve the political bands which have connected them with another, and to assume, among the powers of the earth, the separate and equal station to which the laws of nature and of nature's God entitle them, a decent respect to the opinions of mankind requires *that they should declare the causes which impel them to the separation. We hold these truths to*

Lower case a to z, 14½ ems

ABCDEFGHIJKLMN**OP**QRSTU**VW**XYZ
1234567890

12 POINT SELF SPACING NO 31½

Unit of measure, 7 to Pica

WHEN, in the course of human events, it becomes necessary for one people to dissolve the political bands which have connected them with another, and to assume, among the powers of the earth, the separate and equal station to which the laws of nature and of nature's God entitle them, a *decent respect to the opinions of mankind requires that they should declare the causes which impel*

Lower case a to z, 13½ ems

ABCDEFGHIJKLMN**OP**QRSTU**VW**XYZ
1234567890

MODERN ROMAN SERIES No 45

5 POINT No 45

WHEN, in the course of human events, it becomes necessary for one people to dissolve the political bands which have connected them with another, and to assume, among the powers of the earth, the separate and equal station to which the laws of nature and of nature's God entitle them, a decent respect to the opinions of mankind requires that they should declare the causes which impel them to the separation. We hold these truths to be self-evident, that all men are created equal; that they are endowed by their Creator with certain unalienable rights; that among these, are life, liberty, and the pursuit

Lower case a to z, 15 $\frac{3}{4}$ ems

ABCDEFGHIJKLMN**OP**QRSTUVWXYZ
1234567890

5 $\frac{1}{2}$ POINT No 45

WHEN, in the course of human events, it becomes necessary for one people to dissolve the political bands which have connected them with another, and to assume, among the powers of the earth, the separate and equal station to which the laws of nature and of nature's God entitle them, a decent respect to the opinions of mankind requires that they should declare the causes which impel them to the separation. *We hold these truths to be self-evident, that all men are created equal; that*

Lower case a to z, 16 ems

ABCDEFGHIJKLMN**OP**QRSTUVWXYZ
1234567890

6 POINT No 45

WHEN, in the course of human events, it becomes necessary for one people to dissolve the political bands which have connected them with another, and to assume, among the powers of the earth, the separate and equal station to which the laws of nature and of nature's God entitle them, a decent respect to the opinions of mankind requires that they should declare the causes which impel them to the separation. We hold these truths to be self-evident, that all men are created equal; that they are endowed by their Creator with certain unalienable rights; that among these, are life, liberty, and the pursuit of happiness. That, to secure these rights, governments are instituted among men, deriving their just powers from the consent of the governed; *that, whenever any form of government becomes destructive of these ends, it is the right of the people to alter or to abolish it, and to institute a new govern-*

Lower case a to z, 16 $\frac{1}{4}$ ems

ABCDEFGHIJKLMN**OP**QRSTUVWXYZ
1234567890

7 POINT No 45

WHEN, in the course of human events, it becomes necessary for one people to dissolve the political bands which have connected them with another, and to assume, among the powers of the earth, the separate and equal station to which the laws of nature and of nature's God entitle them, a decent respect to the opinions of mankind requires that they should declare the causes which impel them to the separation. We hold these truths to be self-evident, that all men are created equal; that they are endowed by their Creator with certain unalienable rights; that among these, are life, liberty, and the pursuit of happiness. *That, to secure these rights,*

Lower case a to z, 15 $\frac{3}{4}$ ems

ABCDEFGHIJKLMN**OP**QRSTUVWXYZ
1234567890

8 POINT No 45

WHEN, in the course of human events, it becomes necessary for one people to dissolve the political bands which have connected them with another, and to assume, among the powers of the earth, the separate and equal station to which the laws of nature and of nature's God entitle them, a decent respect to the opinions of mankind requires that they should declare the causes which impel them to the separation. *We hold these truths to be self-evident, that all men are created equal; that they are endowed by their Creator with certain unalienable rights;*

Lower case a to z, 14 $\frac{3}{4}$ ems

ABCDEFGHIJKLMN**OP**QRSTUVWXYZ
1234567890

9 POINT NO 45

WHEN, in the course of human events, it becomes necessary for one people to dissolve the political bands which have connected them with another, and to assume, among the powers of the earth, the separate and equal station to which the laws of nature and of nature's God entitle them, a decent respect to the opinions of mankind requires that they should declare the causes which impel them to the separation. We hold these truths to be self-evident, that all men are created equal; that they are endowed by their Creator with certain unalienable rights; that among these, are life, liberty, and the pursuit of happiness. That, to secure these rights, governments are instituted among men, deriving their just powers from the consent of the governed; that, whenever any form

Lower case a to z, 13 $\frac{2}{3}$ ems

ABCDEFGHIJKLMNOPQRSTUVWXYZ

1234567890

10 POINT NO 45

WHEN, in the course of human events it becomes necessary for one people to dissolve the political bands which have connected them with another, and to assume among the powers of the earth, the separate and equal station to which the laws of nature and of nature's God entitle them, a decent respect to the opinions of mankind requires that they should declare the causes which impel them to the separation. We hold these truths to be self-evident, that all men are created equal; that they are endowed by their Creator with certain unalienable rights; that among these, are life, liberty, and the pursuit of happiness. That, to

Lower case a to z, 13 $\frac{1}{2}$ ems

ABCDEFGHIJKLMNOPQRSTUVWXYZ

1234567890

12 POINT NO 45

WHEN, in the course of human events, it becomes necessary for one people to dissolve the political bands which have connected them with another, and to assume, among the powers of the earth, the separate and equal station to which the laws of nature and of nature's God entitle them, a decent respect to the opinions of mankind requires that they should declare the causes which impel them to the separation. We hold these truths to be self-

Lower case a to z, 13 ems

ABCDEFGHIJKLMNOPQRSTUVWXYZ

1234567890

MODERN ROMAN SERIES No 46

5 POINT No 46

WHEN, in the course of human events, it becomes necessary for one people to dissolve the political bands which have connected them with another, and to assume, among the powers of the earth, the separate and equal station to which the laws of nature and of nature's God entitle them, a decent respect to the opinions of mankind requires that they should declare the causes which impel them to the separation. We hold these truths to be self-evident, that all men are created equal; that they are endowed by their Creator with certain unalienable rights; that among these, are life, liberty, and the pursuit of happiness. That, to secure these rights, governments are instituted among men, deriving their just powers from the consent of the governed; that, whenever any form of govern-

Lower case a to z, 17 ems

ABCDEFGHIJKLMN O P Q R S T U V W
1234567890

5½ POINT No 46

WHEN, in the course of human events, it becomes necessary for one people to dissolve the political bands which have connected them with another, and to assume, among the powers of the earth, the separate and equal station to which the laws of nature and of nature's God entitle them, a decent respect to the opinions of mankind requires that they should declare the causes which impel them to the separation. We hold these truths to be self-evident, that all men are created equal; that they are endowed by their Creator with certain unalienable rights; that among these, are life, liberty, and the pursuit of happiness. *That, to secure these rights, governments are instituted among men, deriving their just*

Lower case a to z, 16 ems

ABCDEFGHIJKLMN O P Q R S T U V W X Y Z
1234567890

6 POINT No 46

WHEN, in the course of human events, it becomes necessary for one people to dissolve the political bands which have connected them with another, and to assume, among the powers of the earth, the separate and equal station to which the laws of nature and of nature's God entitle them, a decent respect to the opinions of mankind requires that they should declare the causes which impel them to the separation. We hold these truths to be self-evident, that all men are created equal; that they are endowed by their Creator with certain unalienable rights; that among these, are life, liberty, and the pursuit of happiness. That, to secure these rights, governments are instituted among men, deriving their just powers from the consent of the governed; that, whenever any form of government becomes destructive of these ends, it is the right of the people to alter or to abolish it, and to institute a new government, laying its foundation on such principles, and organizing its powers in such form, as to them shall seem most likely to effect their safety and happiness. Prudence, indeed, will dictate that governments long established, *should not be changed for light and transient causes; and, accordingly, all experience hath shown that mankind are more disposed to suffer, while evils are sufferable,*

Lower case a to z, 16½ ems

ABCDEFGHIJKLMN O P Q R S T U V W X Y Z
1234567890

7 POINT No 46

WHEN, in the course of human events, it becomes necessary for one people to dissolve the political bands which have connected them with another, and to assume, among the powers of the earth, the separate and equal station to which the laws of nature and of nature's God entitle them, a decent respect to the opinions of mankind requires that they should declare the causes which impel them to the separation. We hold these truths to be self-evident, that all men are created equal; that they are endowed by their Creator with certain unalienable rights; that among these, are life, liberty, and the pursuit of happiness. That, to secure these rights, governments are instituted among men, deriving their just powers from the consent of the governed; that, whenever any *form of government becomes destructive of these ends, it is the right of the people to alter or to abolish it, and to institute a new government, laying its*

Lower case a to z, 16 ems

ABCDEFGHIJKLMN O P Q R S T U V W X Y Z
1234567890

8 POINT NO 46

WHEN, in the course of human events, it becomes necessary for one people to dissolve the political bands which have connected them with another, and to assume, among the powers of the earth, the separate and equal station to which the laws of nature and of nature's God entitle them, a decent respect to the opinions of mankind requires that they should declare the causes which impel them to the separation. We hold these truths to be self-evident, that all men are created equal; that they are endowed by their Creator with certain unalienable rights; that among these, are life, liberty, and the pursuit of happiness. That, to secure these rights, governments are instituted among men, deriving their just powers from the consent of the governed; that, whenever any form of government becomes destructive of these ends, it is the right of the people to alter or to abolish it, and to institute a new government, laying its foundation on such principles, and organizing its powers in such form, as to them shall seem most likely to effect their safety and happiness. Prudence, indeed, will dictate that governments long established, should not be changed for light and transient causes; and, accordingly, all experience hath shown, that mankind are more disposed to suffer, while evils are sufferable, *than to right themselves by abolishing the forms to which they are accustomed. But, when a long train of abuses and usurpations, pursuing*

Lower case a to z, 15¹/₄ emsABCDEFGHIJKLMN**OP**QRSTUVWXYZ

1234567890

9 POINT NO 46

WHEN, in the course of human events, it becomes necessary for one people to dissolve the political bands which have connected them with another, and to assume, among the powers of the earth, the separate and equal station to which the laws of nature and of nature's God entitle them, a decent respect to the opinions of mankind requires that they should declare the causes which impel them to the separation. We hold these truths to be self-evident, that all men are created equal; that they are endowed by their Creator with certain unalienable rights; that among these, are life, liberty, and the pursuit of happiness. That, to secure these rights, governments are instituted among men, deriving their just powers from the consent of the governed; that, whenever any form of government becomes destructive of these ends, it is the right of the people to alter or to abolish it, and to institute a new government, laying its foundation on such principles, and organizing its powers in such form, as to them shall seem most likely to effect their safety and happiness. Prudence, indeed, will dictate that governments long established, should not be changed for

Lower case a to z, 15 ems

ABCDEFGHIJKLMN**OP**QRSTUVWXYZ

1234567890

MODERN ROMAN SERIES No 47

15

5½ POINT No 47

WHEN, in the course of human events, it becomes necessary for one people to dissolve the political bands which have connected them with another, and to assume, among the powers of the earth, the separate and equal station to which the laws of nature and of nature's God entitle them, a decent respect to the opinions of mankind requires that they should declare the causes which impel them to the separation. We hold these truths to be self-evident, that all men are created equal; that they are endowed by their Creator with certain unalienable rights; that among these, are life, liberty, and the pursuit of happiness. That, to secure these rights, governments are instituted among men, deriving their just powers from the consent of the governed; that, whenever any form of government becomes destructive of these ends, it is the right of the people to alter or to abolish it, and to institute a new government, laying its foundations on such principles, and organizing its powers in such form, as to them shall seem most likely to effect their safety and happiness. Prudence, indeed, will dictate that governments long established, should not be changed for light and transient causes; and, accordingly, all experience hath shown, that mankind are more disposed to suffer, while evils are sufferable, than to right themselves by abolishing the forms to which they are accustomed. But, when a long train of abuses and usurpations, pursuing invariably the same object, evinces a design to reduce them under absolute despotism, it is their right, it is their duty, to throw off such government, and to provide new guards for their future security. Such has been the patient sufferance of these colonies, and such is now the necessity which constrains them to alter their former systems of government. *The history of the present king of Great Britain is a history of re-*

Lower case a to z, 15 ems

ABCDEFGHIJKLMN OPQRSTUVWXYZ
1234567890

6 POINT No 47

WHEN, in the course of human events, it becomes necessary for one people to dissolve the political bands which have connected them with another, and to assume, among the powers of the earth, the separate and equal station to which the laws of nature and of nature's God entitle them, a decent respect to the opinions of mankind requires that they should declare the causes which impel them to the separation. We hold these truths to be self-evident, that all men are created equal; that they are endowed by their Creator with certain unalienable rights; that among these, are life, liberty, and the pursuit of happiness. That, to secure these rights, governments are instituted among men, deriving their just powers from the consent of the governed; that, whenever any form of government becomes destructive of these ends, it is the right of the people to alter or to abolish it, and to institute a new government, laying its foundation on such principles, and organizing its powers in such form, as to them shall seem most likely to effect their safety and happiness. Prudence, indeed, will dictate that governments long established, should not be changed for light and transient causes; and, accordingly, all experience hath shown, that mankind are more disposed to suffer, while evils are sufferable, than to right themselves by abolishing the forms to which they are accustomed. *But, when a long train of abuses and usurpations, pursuing invariably the same object, evinces a design to reduce them under absolute despotism, it is their right, it*

Lower case a to z, 15½ ems

ABCDEFGHIJKLMN OPQRSTUVWXYZ
1234567890

7 POINT No 47

WHEN, in the course of human events, it becomes necessary for one people to dissolve the political bands which have connected them with another, and to assume, among the powers of the earth, the separate and equal station to which the laws of nature and of nature's God entitle them, a decent respect to the opinions of mankind requires that they should declare the causes which impel them to the separation. We hold these truths to be self-evident, that all men are created equal; that they are endowed by their Creator with certain unalienable rights; that among these, are life, liberty, and the pursuit of happiness. That, to secure these rights, governments are instituted among men, deriving their just powers from the consent of the governed; that, whenever any form of government becomes destructive of these ends, it is the right of the people to alter or to abolish it, and to institute a new government, laying its foundation on such principles, and organizing its powers in such form, as to them shall seem most likely to effect their safety and happiness. *Prudence, indeed, will dictate that governments long established, should not be changed for light and transient causes;*

Lower case a to z, 14½ ems

ABCDEFGHIJKLMN OPQRSTUVWXYZ
1234567890

8 POINT No 47

WHEN, in the course of human events, it becomes necessary for one people to dissolve the political bands which have connected them with another, and to assume, among the powers of the earth, the separate and equal station to which the laws of nature and of nature's God entitle them, a decent respect to the opinions of mankind requires that they should declare the causes which impel them to the separation. We hold these truths to be self-evident, that all men are created equal; that they are endowed by their Creator with certain unalienable rights; that among these, are life, liberty, and the pursuit of happiness. That, to secure these rights, governments are instituted among men, deriving their just powers from the consent of the governed; that, whenever any form of government becomes destructive of these ends, it is the right of the people to alter or to abolish it, and to institute a new government, laying its foundation

Lower case a to z, 13½ ems

ABCDEFGHIJKLMNOPQRSTUVWXYZ
1234567890

9 POINT No 47

WHEN, in the course of human events, it becomes necessary for one people to dissolve the political bands which have connected them with another, and to assume, among the powers of the earth, the separate and equal station to which the laws of nature and of nature's God entitle them, a decent respect to the opinions of mankind requires that they should declare the causes which impel them to the separation. We hold these truths to be self-evident, that all men are created equal; that they are endowed by their Creator with certain unalienable rights; that among these, are life, liberty, and the pursuit of happiness. That, to secure these rights, governments are instituted among men, deriving their just powers from the consent of the governed; that, whenever any form of government becomes destructive

Lower case a to z, 13 ems

ABCDEFGHIJKLMNOPQRSTUVWXYZ
1234567890

10 POINT No 47

WHEN, in the course of human events, it becomes necessary for one people to dissolve the political bands which have connected them with another, and to assume, among the powers of the earth, the separate and equal station to which the laws of nature and of nature's God entitle them, a decent respect to the opinions of mankind requires that they should declare the causes which impel them to the separation. We hold these truths to be self-evident, that all men are created equal; that they are endowed by their Creator with certain unalienable rights; that among these, are life, liberty, and the pursuit of happiness. That, to secure these rights, governments

Lower case a to z, 14 ems

ABCDEFGHIJKLMNOPQRSTUVWXYZ
1234567890

11 POINT NO 47

WHEN, in the course of human events, it becomes necessary for one people to dissolve the political bands which have connected them with another, and to assume, among the powers of the earth, the separate and equal station to which the laws of nature and of nature's God entitle them, a decent respect to the opinions of mankind requires that they should declare the causes which impel them to the separation. We hold these truths to be self-evident, that all men are created equal; that they are endowed by their Creator with certain unalienable rights; that among these, are life, liberty, and the pursuit of happiness. That, to secure these rights, governments are instituted among men, deriving their just powers from the consent of the governed; that, whenever any form of government *becomes destructive of these ends, it is the right of the people to alter or to abolish it, and to institute a new*

Lower case a to z, 13¹/₂ ems

ABCDEFGHIJKLMNOPQRSTUVWXYZ
1234567890

12 POINT NO 47

WHEN, in the course of human events, it becomes necessary for one people to dissolve the political bands which have connected them with another, and to assume, among the powers of the earth, the separate and equal station to which the laws of nature and of nature's God entitle them, a decent respect to the opinions of mankind requires that they should declare the causes which impel them to the separation. We hold these truths to be self-evident, that all men are created equal; that they are endowed by their Creator with certain unalienable rights; that among these, are life, liberty, and the pursuit of happiness. That, to secure these rights, governments *are instituted among men, deriving their just powers from the consent of the governed; that, whenever any*

Lower case a to z, 13²/₃ ems

ABCDEFGHIJKLMNOPQRSTUVWXYZ
1234567890

MODERN ROMAN SERIES No 49

6 POINT NO 49

WHEN, in the course of human events, it becomes necessary for one people to dissolve the political bands which have connected them with another, and to assume, among the powers of the earth, the separate and equal station to which the laws of nature and of nature's God entitle them, a decent respect to the opinions of mankind requires that they should declare the causes which impel them to the separation. We hold these truths to be self-evident, that all men are created equal; that they are endowed by their Creator with certain unalienable rights; that among these, are life, liberty, and the pursuit of happiness. That, to secure these rights, governments are instituted among men, deriving their just powers from the consent of the governed; that, whenever any form of government becomes destructive of these ends, it is the right of the people to alter or to abolish it, and to institute a new government, laying its foundation on such principles, and organizing its powers in such form, as to them shall seem most likely to effect their safety and happiness. Prudence, indeed, will dictate that governments long established, should not be changed for light and transient causes; and, accordingly, all experience hath shown, that mankind are more disposed to suffer, while evils are sufferable, than to right

Lower case a to z, 16 ems

ABCDEFGHIJKLMN OPQRSTUVWXYZ

1234567890

7 POINT NO 49

WHEN, in the course of human events, it becomes necessary for one people to dissolve the political bands which have connected them with another, and to assume, among the powers of the earth, the separate and equal station to which the laws of nature and of nature's God entitle them, a decent respect to the opinions of mankind requires that they should declare the causes which impel them to the separation. We hold these truths to be self-evident, that all men are created equal; that they are endowed by their Creator with certain unalienable rights; that among these, are life, liberty, and the pursuit of happiness. That, to secure these rights, governments are instituted among men, deriving their just powers from the governed; that, whenever any form of government becomes destructive of these ends, it is the right of the people to alter or to abolish it, and to institute a new government, laying its foundation on such principles, and organizing

Lower case a to z, 15½ ems

ABCDEFGHIJKLMN OPQRSTUVWXYZ

1234567890

8 POINT NO 49

WHEN, in the course of human events, it becomes necessary for one people to dissolve the political bands which have connected them with another, and to assume, among the powers of the earth, the separate and equal station to which the laws of nature and of nature's God entitle them, a decent respect to the opinions of mankind requires that they should declare the causes which impel them to the separation. We hold these truths to be self-evident, that all men are created equal; that they are endowed by their Creator with certain unalienable rights; that among these, are life, liberty, and the pursuit of happiness. That, to secure these rights, governments are instituted among men, deriving their just powers from the consent of the governed; that, whenever

Lower case a to z, 14½ ems

ABCDEFGHIJKLMN OPQRSTUVWXYZ

1234567890

MODERN ROMAN SERIES No 50

"

6 POINT No 50

WHEN, in the course of human events, it becomes necessary for one people to dissolve the political bands which have connected them with another, and to assume, among the powers of the earth, the separate and equal station to which the laws of nature and of nature's God entitle them, a decent respect to the opinions of mankind requires that they should declare the causes which impel them to the separation. We hold these truths to be self-evident, that all men are created equal; that they are endowed by their Creator with certain unalienable rights; that among these, are life, liberty, and the pursuit of happiness. That, to secure these rights, governments are instituted among men, deriving their just powers from the consent of the governed; that, whenever any form of government becomes destructive of these ends, it is the right of the people to alter or to abolish it, and to institute a new government, laying its foundation on such principles, and organizing its powers in such form, as to them shall seem most likely to effect their safety and happiness. Prudence, indeed, will dictate that governments long established, should not be changed for light and transient causes; and, accordingly, all experience hath shown, that mankind are more disposed to suffer, while evils are sufferable, than to right

Lower case a to z, 15¼ ems

ABCDEFGHIJKLMNOPQRSTUVWXYZ
1234567890

7 POINT No 50

WHEN, in the course of human events, it becomes necessary for one people to dissolve the political bands which have connected them with another, and to assume, among the powers of the earth, the separate and equal station to which the laws of nature and of nature's God entitle them, a decent respect to the opinions of mankind requires that they should declare the causes which impel them to the separation. We hold these truths to be self-evident, that all men are created equal; that they are endowed by their Creator with certain unalienable rights; that among these, are life, liberty, and the pursuit of happiness. That, to secure these rights, governments are instituted among men, deriving their just powers from the consent of the governed; that, whenever any form of government becomes destructive of these ends, it is the right of the people to alter or to abolish it, and to institute a new government, laying its foundation on such principles, and

Lower case a to z, 14¾ ems

ABCDEFGHIJKLMNOPQRSTUVWXYZ
1234567890

8 POINT No 50

WHEN, in the course of human events, it becomes necessary for one people to dissolve the political bands which have connected them with another, and to assume, among the powers of the earth, the separate and equal station to which the laws of nature and of nature's God entitle them, a decent respect to the opinions of mankind requires that they should declare the causes which impel them to the separation. We hold these truths to be self-evident, that all men are created equal; that they are endowed by their Creator with certain unalienable rights; that among these, are life, liberty, and the pursuit of happiness. That, to secure these rights, governments are instituted among men, deriving their just powers from the consent of the governed;

Lower case a to z, 14 ems

ABCDEFGHIJKLMNOPQRSTUVWXYZ
1234567890

9 POINT NO 50

WHEN, in the course of human events, it becomes necessary for one people to dissolve the political bands which have connected them with another, and to assume, among the powers of the earth, the separate and equal station to which the laws of nature and of nature's God entitle them, a decent respect to the opinions of mankind requires that they should declare the causes which impel them to the separation. We hold these truths to be self-evident, that all men are created equal; that they are endowed by their Creator with certain unalienable rights; that among these, are life, liberty, and the pursuit of happiness. That, to secure these rights, governments are instituted among men, deriving their just powers from the consent of the governed; that, whenever any form of government becomes destructive of these ends, it is the right of the people to alter or to abolish it, and to institute a new government, laying its foundation on such principles, and organizing its powers in such form, as to them shall seem most likely to effect their safety and happiness. Prudence, indeed, will dictate that governments long established, should not be changed for light and transient causes; and, accordingly, all experience

Lower case a to z, 14 ems

ABCDEFGHIJKLMN OPQRSTUVWXYZ
1234567890

10 POINT NO 50

WHEN, in the course of human events, it becomes necessary for one people to dissolve the political bands which have connected them with another, and to assume, among the powers of the earth, the separate and equal station to which the laws of nature and of nature's God entitle them, a decent respect to the opinions of mankind requires that they should declare the causes which impel them to the separation. We hold these truths to be self-evident, that all men are created equal; that they are endowed by their Creator with certain unalienable rights; that among these, are life, liberty, and the pursuit of happiness. That, to secure these rights, governments are instituted among men, deriving their just powers from the consent of the governed; that, whenever any form of government becomes destructive of these ends, it is the right of the people to alter or to abolish it, and to institute a new government, laying its foundation on such principles, and or-

Lower case a to z, 13 $\frac{3}{4}$ ems

ABCDEFGHIJKLMN OPQRSTUVWXYZ
1234567890

INLAND SERIES No 56

5½ POINT No 56

WHEN, in the course of human events, it becomes necessary for one people to dissolve the political bands which have connected them with another, and to assume, among the powers of the earth, the separate and equal station to which the laws of nature and of nature's God entitle them, a decent respect to the opinions of mankind requires that they should declare the causes which impel them to the separation. We hold these truths to be self-evident, that all men are created equal; that they are endowed by their Creator with certain unalienable rights; that among these, are life, liberty, and the pursuit of happiness. That, to secure these rights, governments are instituted among men, deriving their just powers from the consent of the governed; that, whenever any form of government becomes destructive of these ends, it is the right of the people to alter or to abolish it, and to institute a new government, laying its foundation on such principles, and organizing its powers in such form, as to them shall seem most likely to effect their safety and happiness. Prudence, indeed, will dictate that governments long established, should not be changed for light and transient causes; and, accordingly, all experience hath shown, that mankind are more disposed to suffer, while evils are sufferable, than to right themselves by abolishing the forms to which they are accustomed. But, when a long train of abuses and usurpations pursuing invariably the same object, evinces a design to reduce them

Lower case a to z, 17½ ems

ABCDEFGHIJKLMNOPQRSTUVWXYZ

1234567890

6 POINT No 56

WHEN, in the course of human events, it becomes necessary for one people to dissolve the political bands which have connected them with another, and to assume, among the powers of the earth, the separate and equal station to which the laws of nature and of nature's God entitle them, a decent respect to the opinions of mankind requires that they should declare the causes which impel them to the separation. We hold these truths to be self-evident, that all men are created equal; that they are endowed by their Creator with certain unalienable rights; that among these are, life, liberty, and the pursuit of happiness. That, to secure these rights, governments are instituted among men, deriving their just powers from the consent of the governed; that, whenever any form of government becomes destructive of these ends, it is the right of the people to alter or to abolish it, and to institute a new government, laying its foundation on such principles, and organizing its powers in such form, as to them shall seem most likely to effect their safety and happiness. Prudence, indeed, will dictate that governments long established, should not be changed for light and transient causes; and, accordingly, all expe-

Lower case a to z, 18 ems

ABCDEFGHIJKLMNOPQRSTUVWXYZ

1234567890

7 POINT No 56

WHEN, in the course of human events, it becomes necessary for one people to dissolve the political bands which have connected them with another, and to assume, among the powers of the earth, the separate and equal station to which the laws of nature and of nature's God entitle them, a decent respect to the opinions of mankind requires that they should declare the causes which impel them to the separation. We hold these truths to be self-evident, that all men are created equal; that they are endowed by their Creator with certain unalienable rights; that among these, are life, liberty, and the pursuit of happiness. That, to secure these rights, governments are instituted among men, deriving their just powers from the consent of the governed; that, whenever any form of government becomes destructive of these ends, it is the right of the people to alter or to abolish it, and to institute a new

Lower case a to z, 17 ems

ABCDEFGHIJKLMNOPQRSTUVWXYZ

1234567890

8 POINT NO 56

WHEN, in the course of human events, it becomes necessary for one people to dissolve the political bands which have connected them with another, and to assume, among the powers of the earth, the separate and equal station to which the laws of nature and of nature's God entitle them, a decent respect to the opinions of mankind requires that they should declare the causes which impel them to the separation. We hold these truths to be self-evident, that all men are created equal; that they are endowed by their Creator with certain unalienable rights; that among these, are life, liberty, and the pursuit of happiness. That, to secure these rights, governments are instituted among men, deriving their just powers from the consent of the governed; that,

Lower case a to z, 15½ ems

ABCDEFGHIJKLMNOPQRSTUVWXYZ

1234567890

9 POINT NO 56

WHEN, in the course of human events, it becomes necessary for one people to dissolve the political bands which have connected them with another, and to assume, among the powers of the earth, the separate and equal station to which the laws of nature and of nature's God entitle them, a decent respect to the opinions of mankind requires that they should declare the causes which impel them to the separation. We hold these truths to be self-evident, that all men are created equal; that they are endowed by their Creator with certain unalienable rights; that among these, are life, liberty, and the pursuit of happiness. That, to secure these rights, governments

Lower case a to z, 15 ems

ABCDEFGHIJKLMNOPQRSTUVWXYZ

1234567890

10 POINT NO 56

WHEN, in the course of human events, it becomes necessary for one people to dissolve the political bands which have connected them with another, and to assume, among the powers of the earth, the separate and equal station to which the laws of nature and of nature's God entitle them, a decent respect to the opinions of mankind requires that they should declare the causes which impel them to the separation. We hold these truths to be self-evident, that all men are created equal; that they are endowed by their Creator with certain unalienable rights; that among these,

Lower case a to z, 14¾ ems

ABCDEFGHIJKLMNOPQRSTUVWXYZ

1234567890

MODERN ROMAN SERIES No 57

5 POINT NO 57

WHEN, in the course of human events, it becomes necessary for one people to dissolve the political bands which have connected them with another, and to assume, among the powers of the earth, the separate and equal station to which the laws of nature and of nature's God entitle them, a decent respect to the opinions of mankind requires that they should declare the causes which impel them to the separation. We hold these truths to be self-evident, that all men are created equal; that they are endowed by their Creator with certain unalienable rights; that among these, are life, liberty, and pursuit of happiness. That, to secure these rights, governments are instituted among men, deriving their just powers from the consent of the governed; that, whenever any form of government becomes destruc-

Lower case a to z, 17 ems

ABCDEFGHIJKLMNOPQRSTUVWXYZ
1234567890

5½ POINT NO 57

WHEN, in the course of human events, it becomes necessary for one people to dissolve the political bands which have connected them with another, and to assume, among the powers of the earth, the separate and equal station to which the laws of nature and of nature's God entitle them, a decent respect to the opinions of mankind requires that they should declare the causes which impel them to the separation. We hold these truths to be self-evident, that all men are created equal; that they are endowed by their Creator with certain unalienable rights; that among these, are life, liberty, and the pursuit of happiness. That, to secure these rights, governments are instituted among men, deriving their

Lower case a to z, 16 ems

ABCDEFGHIJKLMNOPQRSTUVWXYZ
1234567890

6 POINT NO 57

WHEN, in the course of human events, it becomes necessary for one people to dissolve the political bands which have connected them with another, and to assume, among the powers of the earth, the separate and equal station to which the laws of nature and of nature's God entitle them, a decent respect to the opinions of mankind requires that they should declare the causes which impel them to the separation. We hold these truths to be self-evident, that all men are created equal; that they are endowed by their Creator with certain unalienable rights; that among these, are life, liberty, and the pursuit of happiness. That, to secure these rights, governments are instituted among men, deriving their just powers from the consent of the governed; that, whenever any form of government becomes destructive of these ends, it is the right of the people to alter or to abolish it, and to institute a new government, laying its foundation on such principles, and organizing its powers in such form, as to them shall seem most likely to effect their safety and happiness. Prudence, indeed, will dictate that governments long established, *should not be changed for light and transient causes; and, accordingly, all experience hath shown, that mankind are more disposed to suffer, while evils are*

Lower case a to z, 15½ ems

ABCDEFGHIJKLMNOPQRSTUVWXYZ
1234567890

7 POINT NO 57

WHEN, in the course of human events, it becomes necessary for one people to dissolve the political bands which have connected them with another, and to assume, among the powers of the earth, the separate and equal station to which the laws of nature and of nature's God entitle them, a decent respect to the opinions of mankind requires that they should declare the causes which impel them to the separation. We hold these truths to be self-evident, that all men are created equal; that they are endowed with certain unalienable rights; that among these, are life, liberty, and the pursuit of happiness. That, to secure these rights, governments are instituted among men, deriving their just powers from the consent of the governed; that, whenever any form of government becomes destructive of these ends, it is the right of the people to alter or to abolish it, and to institute a new government, laying its foundation on such principles, and organizing its powers in

Lower case a to z, 14½ ems

ABCDEFGHIJKLMNOPQRSTUVWXYZ
1234567890

8 POINT NO 57

WHEN, in the course of human events, it becomes necessary for one people to dissolve the political bands which have connected them with another, and to assume, among the powers of the earth, the separate and equal station to which the laws of nature and of nature's God entitle them, a decent respect to the opinions of mankind requires that they should declare the causes which impel them to the separation. We hold these truths to be self-evident, that all men are created equal; that they are endowed by their Creator with certain unalienable rights; that among these, are life, liberty, and the pursuit of happiness. That, to secure these rights, governments are instituted among men, deriving *their just powers from the consent of the governed*; that *whenever any form of government becomes destructive of these ends,*

Lower case a to z, 14 ems

ABCDEFGHIJKLMNOPQRSTUVWXYZ
1234567890

9 POINT NO 57

WHEN, in the course of human events, it becomes necessary for one people to dissolve the political bands which have connected them with another, and to assume, among the powers of the earth, the separate and equal station to which the laws of nature and of nature's God entitle them, a decent respect to the opinions of mankind requires that they should declare the causes which impel them to the separation. We hold these truths to be self-evident, that all men are created equal; that they are endowed by their Creator with certain unalienable rights; that among these, are *life, liberty, and the pursuit of happiness. That, to secure these rights, governments are instituted among men, deriving their just*

Lower case a to z, 13½ ems

ABCDEFGHIJKLMNOPQRSTUVWXYZ
1234567890

10 POINT NO 57

WHEN, in the course of human events, it becomes necessary for one people to dissolve the political bands which have connected them with another, and to assume, among the powers of the earth, the separate and equal station to which the laws of nature and of nature's God entitle them, a decent respect to the opinions of mankind requires that they should declare the causes which impel them to the separation. We hold these truths to be self-evident, that all men are created *equal; that they are endowed by their Creator with certain unalienable rights; that among these, are life, liberty, and*

Lower case a to z, 13¼ ems

ABCDEFGHIJKLMNOPQRSTUVWXYZ
1234567890

SCRIPPS SERIES No 58

5½ POINT NO 58

WHEN, in the course of human events, it becomes necessary for one people to dissolve the political bands which have connected them with another, and to assume, among the powers of the earth, the separate and equal station to which the laws of nature and of nature's God entitle them, a decent respect to the opinions of mankind requires that they should declare the causes which impel them to the separation. We hold these truths to be self-evident, that all men are created equal; that they are endowed with certain unalienable rights; that among these, are life, liberty, and the pursuit of happiness. That, to secure these rights, governments are instituted among men, deriving their just powers from the consent of the governed; that, whenever any form of government becomes destructive of these ends, it is the right of the people to alter it or to abolish it, and to institute a new government, laying its foundation on such principles, and organizing its powers in such form, as to them shall seem most likely to effect their safety and happiness. Prudence, indeed, will dictate that governments long established, should not be changed for light and transient causes; and, accordingly, all experience hath shown, that mankind are more disposed to suffer, while evils are sufferable, than to *right themselves by abolishing the forms to which they are accustomed. But, when a long train of abuses and usurpations, pursuing invariably the same object, evinces a design to*

Lower case a to z, 16½ ems

ABCDEFGHIJKLMN OPQRSTUVWXYZ
1234567890

6 POINT NO 58

WHEN, in the course of human events, it becomes necessary for one people to dissolve the political bands which have connected them with another, and to assume, among the powers of the earth, the separate and equal station to which the laws of nature and of nature's God entitle them, a decent respect to the opinions of mankind requires that they should declare the causes which impel them to the separation. We hold these truths to be self-evident, that all men are created equal; that they are endowed by their Creator with certain unalienable rights; that among these, are life, liberty, and the pursuit of happiness. That, to secure these rights, governments are instituted among men, deriving their just powers from the consent of the governed; that, whenever any form of government becomes destructive of these ends, it is the right of the people to alter or to abolish it, and to institute a new government, laying its foundation on such principles, and organizing its powers in such form, as to them shall seem most likely to effect their safety and happiness. Prudence, indeed, will dictate that *governments long established, should not be changed for light and transient causes; and, accordingly, all experience hath shown, that mankind are more disposed to suffer,*

Lower case a to z, 16¾ ems

ABCDEFGHIJKLMN OPQRSTUVWXYZ
1234567890

7 POINT NO 58

WHEN, in the course of human events, it becomes necessary for one people to dissolve the political bands which have connected them with another, and to assume, among the powers of the earth, the separate and equal station to which the laws of nature and of nature's God entitle them, a decent respect to the opinions of mankind requires that they should declare the causes which impel them to the separation. We hold these truths to be self-evident, that all men are created equal; that they are endowed by their Creator with certain unalienable rights; that among these, are life, liberty, and the pursuit of happiness. That, to secure these rights, governments are instituted among men, deriving their just powers from the consent of the governed; that, whenever any form of government becomes destructive of these ends, it is the right of the people to alter or to abolish it, and to institute a new government, laying its foundation on such principles,

Lower case a to z, 15¾ ems

ABCDEFGHIJKLMN OPQRSTUVWXYZ
1234567890

8 POINT NO 58

WHEN, in the course of human events, it becomes necessary for one people to dissolve the political bands which have connected them with another, and to assume, among the powers of the earth, the separate and equal station to which the laws of nature and of nature's God entitle them, a decent respect to the opinions of mankind requires that they should declare the causes which impel them to the separation. We hold these truths to be self-evident, that all men are created equal; that they are endowed by their Creator with certain unalienable rights; that among these, are life, liberty, and the pursuit of happiness. That, to secure these rights, governments are instituted among men, deriving their just powers from the consent of the governed; that, whenever any form of government becomes

Lower case a to z, 14½ ems

ABCDEFGHIJKLMNOPQRSTUVWXYZ

1234567890

9 POINT NO 58

WHEN, in the course of human events, it becomes necessary for one people to dissolve the political bands which have connected them with another, and to assume, among the powers of the earth, the separate and equal station to which the laws of nature and of nature's God entitle them, a decent respect to the opinions of mankind requires that they should declare the causes which impel them to the separation. We hold these truths to be self-evident, that all men are created equal; that they are endowed by their Creator with certain unalienable rights; that among these, are life, liberty, and the pursuit of happiness. That, to secure these rights, governments are instituted among men, deriving their just

Lower case a to z, 13¼ ems

ABCDEFGHIJKLMNOPQRSTUVWXYZ

1234567890

10 POINT NO 58

WHEN, in the course of human events, it becomes necessary for one people to dissolve the political bands which have connected them with another, and to assume, among the powers of the earth, the separate and equal station to which the laws of nature and of nature's God entitle them, a decent respect to the opinions of mankind requires that they should declare the causes which impel them to the separation. We hold these truths to be self-evident, that all men are created equal; that they are endowed by their Creator with certain unalienable rights; that among these, are life, liberty,

Lower case a to z, 13¼ ems

ABCDEFGHIJKLMNOPQRSTUVWXYZ

1234567890

11 POINT No 58

WHEN, in the course of human events, it becomes necessary for one people to dissolve the political bands which have connected them with another, and to assume, among the powers of the earth, the separate and equal station to which the laws of nature and of nature's God entitle them, a decent respect to the opinions of mankind requires that they should declare the causes which impel them to the separation. We hold these truths to be self-evident, that all men are created equal; that they are endowed by their Creator with certain unalienable rights; that among these, are life, liberty, and the pursuit of happiness. That, to secure these rights, governments are instituted among men, deriving their just powers from the consent of the governed; that, whenever any form of government becomes destructive of these ends, it is the right of the people to alter or to abolish it, and to institute a new government, laying its foundation

Lower case a to z, 13 ems

ABCDEFGHIJKLMN OPQRSTUVWXYZ

1234567890

12 POINT No 58

WHEN, in the course of human events, it becomes necessary for one people to dissolve the political bands which have connected them with another, and to assume, among the powers of the earth, the separate and equal station to which the laws of nature and of nature's God entitle them, a decent respect to the opinions of mankind requires that they should declare the causes which impel them to the separation. We hold these truths to be self-evident, that all men are created equal; that they are endowed by their Creator with certain unalienable rights; that among these, are life, liberty, and the pursuit of happiness. That, to secure these rights, governments are instituted among men, deriving their just powers from the consent of the governed; that, whenever any form of

Lower case a to z, 13 1/4 ems

ABCDEFGHIJKLMN OPQRSTUVWXYZ

1234567890

AMERICAN PRESS ASSOCIATION SERIES No 61

6 POINT No 61

WHEN, in the course of human events, it becomes necessary for one people to dissolve the political bands which have connected them with another, and to assume, among the powers of the earth, the separate and equal station to which the laws of nature and of nature's God entitle them, a decent respect to the opinions of mankind requires that they should declare the causes which impel them to the separation. We hold these truths to be self-evident, that all men are created equal; that they are endowed by their Creator with certain unalienable rights; that among these, are life, liberty, and the pursuit of happiness. That, to secure these rights, governments are instituted among men, deriving their just powers from the consent of the governed; that, whenever any form of government becomes

Lower case a to z, 16 $\frac{1}{2}$ ems

ABCDEFGHIJKLMNQRSTUWXYZ

1234567890

7 POINT No 61

WHEN, in the course of human events, it becomes necessary for one people to dissolve the political bands which have connected them with another, and to assume, among the powers of the earth, the separate and equal station to which the laws of nature and of nature's God entitle them, a decent respect to the opinions of mankind requires that they should declare the causes which impel them to the separation. We hold these truths to be self-evident, that all men are created equal; that they are endowed by their Creator with certain unalienable rights; that among these, are life,

Lower case a to z, 15 $\frac{1}{2}$ ems

ABCDEFGHIJKLMNQRSTUWXYZ

1234567890

8 POINT No 61

WHEN, in the course of human events, it becomes necessary for one people to dissolve the political bands which have connected them with another, and to assume, among the powers of the earth, the separate and equal station to which the laws of nature and of nature's God entitle them, a decent respect to the opinions of mankind requires that they should declare the causes which impel them to the separation. We hold these truths to be self-evident, that all men are created equal; that they are endowed by their Creator with certain unalienable

Lower case a to z, 14 $\frac{1}{2}$ ems

ABCDEFGHIJKLMNQRSTUWXYZ

1234567890

9 POINT No 61

WHEN, in the course of human events, it becomes necessary for one people to dissolve the political bands which have connected them with another, and to assume, among the powers of the earth, the separate and equal station to which the laws of nature and of nature's God entitle them, a decent respect to the opinions of mankind requires that they should declare the causes which impel them to the separation. We hold these

Lower case a to z, 14 $\frac{1}{2}$ ems

ABCDEFGHIJKLMNQRSTUWXYZ

1234567890

OHIO SERIES

5 1/2 POINT No 66 °

WHEN, in the course of human events, it becomes necessary for one people to dissolve the political bands which have connected them with another, and to assume, among the powers of the earth, the separate and equal station to which the laws of nature and of nature's God entitle them, a decent respect to the opinions of mankind requires that they should declare the causes which impel them to the separation. We hold these truths to be self-evident, that all men are created equal; that they are endowed by their Creator with certain unalienable rights; that among these, are life, liberty, and the pursuit of happiness. That, to secure these rights, governments are instituted among men, deriving their just powers from the consent of the governed: that

Lower case a to z, 15 ems

ABCDEFGHIJKLMNQRSTUWXYZ
1234567890

6 POINT No 118 °

WHEN, in the course of human events, it becomes necessary for one people to dissolve the political bands which have connected them with another, and to assume, among the powers of the earth, the separate and equal station to which the laws of nature and of nature's God entitle them, a decent respect to the opinions of mankind requires that they should declare the causes which impel them to the separation. We hold these truths to be self-evident, that all men are created equal; that they are endowed by their Creator with certain unalienable rights; that among these, are life, liberty, and the pursuit of happiness. That, to se-

Lower case a to z, 15 1/2 ems

ABCDEFGHIJKLMNQRSTUWV
1234567890

7 POINT No 62 °

WHEN, in the course of human events, it becomes necessary for one people to dissolve the political bands which have connected them with another, and to assume, among the powers of the earth, the separate and equal station to which the laws of nature and of nature's God entitle them, a decent respect to the opinions of mankind requires that they should declare the causes which impel them to the separation. We hold these truths to be self-evident, that all men are created equal; that they are endowed by their Creator with certain unalienable rights; that among these, are life, liberty, and the pursuit of happiness. That, to secure these rights, governments are instituted among men, deriving their just powers from the consent of the governed: that, whenever any form of government becomes destructive of these ends, it is the right of the people to alter or to abolish it, and to institute a new government, laying its foundation on such principles, and organizing its powers in such form, as

Lower case a to z, 14 3/4 ems

ABCDEFGHIJKLMNQRSTUWXYZ
1234567890

8 POINT No 62 °

WHEN, in the course of human events, it becomes necessary for one people to dissolve the political bands which have connected them with another, and to assume, among the powers of the earth, the separate and equal station to which the laws of nature and of nature's God entitle them, a decent respect to the opinions of mankind requires that they should declare the causes which impel them to the separation. We hold these truths to be self-evident, that all men are created equal; that they are endowed by their Creator with certain unalienable rights; that among these, are life, liberty, and the pursuit of happiness. That, to secure these rights, governments are instituted among men, deriving their just powers from the con-

Lower case a to z, 14 7/8 ems

ABCDEFGHIJKLMNQRSTUWXYZ
1234567890

KENTUCKY SERIES

6 POINT No 62

WHEN, in the course of human events, it becomes necessary for one people to dissolve the political bands which have connected them with another, and to assume, among the powers of the earth, the separate and equal station to which the laws of nature and of nature's God entitle them, a decent respect to the opinions of mankind requires that they should declare the causes which impel them to the separation. We hold these truths to be self-evident, that all men are created equal; that they are endowed by their Creator with certain unalienable rights; that among these, are life, liberty, and the pursuit of happiness. That, to secure these rights, governments are instituted among men, deriving their just powers from the consent of the governed; that, whenever any form of government becomes destructive of

Lower case a to z, 16½ ems

ABCDEFGHIJKLMN**OP**QRSTU**VW**XYZ
1234567890

7 POINT No 69

WHEN, in the course of human events, it becomes necessary for one people to dissolve the political bands which have connected them with another, and to assume, among the powers of the earth, the separate and equal station to which the laws of nature and of nature's God entitle them, a decent respect to the opinions of mankind requires that they should declare the causes which impel them to the separation. We hold these truths to be self-evident, that all men are created equal; that they are endowed by their Creator with certain unalienable rights; that among these, are life, liberty, and

Lower case a to z, 15 1-5 ems

ABCDEFGHIJKLMN**OP**QRSTU**V**WXYZ
1234567890

8 POINT No 69

WHEN, in the course of human events, it becomes necessary for one people to dissolve the political bands which have connected them with another, and to assume, among the powers of the earth, the separate and equal station to which the laws of nature and of nature's God entitle them, a decent respect to the opinions of mankind requires that they should declare the causes which impel them to the separation. We hold these truths to be self-evident, that all men are created equal; that they are endowed by their Creator with certain

Lower case a to z, 15 ems

ABCDEFGHIJKLMN**OP**QRSTU**VW**XYZ
1234567890

9 POINT No 69

WHEN, in the course of human events, it becomes necessary for one people to dissolve the political bands which have connected them with another, and to assume, among the powers of the earth, the separate and equal station to which the laws of nature and of nature's God entitle them, a decent respect to the opinions of mankind requires that they should declare the causes which impel them to the separation. We hold these truths to be self-

Lower case a to z, 13 4-5 ems

ABCDEFGHIJKLMN**OP**QRSTU**VW**XYZ
1234567890

CENTURY ROMAN

8 POINT

THE first number of *The Century* appeared in a modernized old-style type, which was then something of a novelty. It had never been used in any similar publication, and it gave distinction to the page. It had authority in its favor, as the outgrowth of a style (shown on pages 127 and 128 of this book), brought out by WILLIAM CASLON of London about 1720, and then so pleasingly cut that it broke down every attempt at rivalry. For seventy years it was commended as incomparably the best cut of type, but it went out of fashion. At the beginning of the present century readers complained of its angularity and grayness.

THEY demanded new styles, and the type-founders provided them in profusion: the Thorne fat-face of prodigious blackness; the Didot round-face, not quite as black or fat-faced; the Bodoni, with round letters and sharp hair-lines; the French poetic face, compressed to the extreme of tenuity; the so-called Scotch-face (devised by the late S. N. DICKINSON of Boston, who established the Dickinson Type Foundry, the Boston Branch of the American Type Founders' Company, although first cut in Edinburgh); and the skeleton light-face, with its razor-edged hair-lines and needle-like pointed stems, fashionable during the first part of century

Lower case a to z, 12 ems

ABCDEFGHIJKLMN OPQRSTUVWXYZ — \$1234567890

9 POINT

WHEN PICKERING and WHITTINGHAM revived the CASLON Old-Style, in 1850, using the identical matrices of the old master, the connoisseurs said, "Now at last we have returned to simplicity and beauty; this is perfection!" Yet it was admired by bibliophiles only; dainty readers did not approve of its angular letters and its disproportioned capitals. Accepted for reprints of old books, it was rejected for modern work. To make it palatable to the general reader, type-founders devised a "modernized old-style," in which harsh features were modified and new features of great delicacy were added. So changed, it became a more salable letter, but it never found marked favor with the ordinary newspaper or the book publisher. Critics said of it (too severely, we think) that the strong features of the Caslon face had been suppressed, and that the new features were no improvement; that it had been made lighter, sharper, and broader, until its true character had been cut to pieces.

Lower case a to z, 12½ ems

ABCDEFGHIJKLMN OPQRSTUVWXYZ — \$1234567890

10 POINT

BIBLIOPHILES still prefer the cut of CASLON; with all its admitted faults, it is blacker, clearer, and more readable. The average reader rejects the angularities of the old and the new cut, and prefers the symmetry of types of modern fashion. In the bewildering variety of faces devised during this century, one peculiarity, the sharp hair-line (a fashion introduced by BODONI and DIDOT, in imitation of the delicate lines of the copper-plate printer), has never been changed. When printing was done upon wet paper, against an elastic blanket, the hair-line was necessarily thickened by its impress against the yielding paper, which over-lapped the sides of every line. Under this treatment the hair-line appeared thicker in print than in type, and was unobjectionable to printer or reader; but when the new method began (as it did in 1872) of printing on dry and smooth paper against an inelastic surface

Lower case a to z, 12 ems

ABCDEFGHIJKLMN OPQRSTUVWXYZ — \$1234567890

MR. THEODORE L. DEVINNE ON THE CENTURY ROMAN.

(From *The Century*, March, 1896.)

[NOTE.—This series of modern Roman type was cut by the American Type Founders' Company for *The Century*, in accordance with the suggestions and under the supervision of Mr. THEODORE L. DEVINNE, the eminent printer of that magazine. The punches were cut on the Benton punch-cutting machine from one set of drawings. A very complete line of accents has been added to meet the requirements of high-class book and magazine work.]

A GREAT change has taken place in the taste of readers, who have wearied of light types and gray impressions. There is an unmistakable demand for bold and stronger print. American type-founders recently introduced several styles of bold and black letter—for publishers and advertisers, as well as for bibliophiles. The "Jenson," "Monotone" and the "DeVenne" are in high favor with all, not for their novelty of form, but for their greater legibility. With these evidences before them of a general preference for bolder types, the publishers of *The Century* decided that they would swim with the tide, and have types of larger face and thicker hair-lines. According to old rules, Roman types would be bolder and more readable when made larger and wider. Experiments made with broad letters proved that increased expansion did not always secure increased legibility. The broad and round faces which seemed so beautiful in large-margined pages of Bodoni and Didot were not all beautiful (quite the reverse) when printed in double columns on a page with narrow margins. To use types in which the thick strokes of each type are unduly spread apart on a page with narrow margins is an incongruity that cannot be justified. When margins are ample, and space is not pinched, types may be broad and even expanded. When the page is over-full, the types should be compressed to suit the changed condition. The fault of over-broad type is most noticed in books of poetry, in which

the narrowness of the measure compels an overturning and mangling of lines, a waste of space, and needless irritation to the reader. Experiment proved that a book-type moderately compressed and properly cut was as readable as round or expanded type. Compressed types, first made in Holland in 1732, ever since have been more largely used than types of any other cut by the printers of France and southern Europe. In dictionaries and books of two or more columns to the page, the compressed face is a necessity. The slightness of the compression in this new face will be perceived at a glance in a comparison of the alphabets of the old and of the new face as here submitted:

abcdefghijklmnopqrstuvwxyzaBCD

THE NEW FACE.

abcdefghijklmnopqrstuvwxyzaBCD

THE OLD FACE.

The new face is as wide as the old; it has as much open space within as without each letter, and just as many letters to the line; it has the greater clearness of a thickened hair-line. It seems to be compressed only because it is taller, but this increase of height amounts to only sixty-five ten-thousandths ($\frac{65}{10000}$) of an inch.

The story of the designing of this face is too full of technical detail to interest the casual reader. Only a maker of instruments of precision can appreciate the subservient tools, gauges, and machines that show aberrations of a ten-thousandth part of an inch; only an expert punch cutter can understand why minute geo-

POSTER LINING ROMAN No 153

18 POINT POSTER LINING ROMAN NO 153

10 A 4 A 16 a 83 25

DECLARES INDEPENDENCE

WHEN, in the course of events, it becomes necessary for one people to dissolve the bands which have joined them with another, and to assume, among the powers of 53

24 POINT POSTER LINING ROMAN NO 153

6 A 4 A 10 a 84 25

PRECIOUS DOCUMENTS

WHEN, in course of time, it becomes necessary for one people to break the bands which have joined them to another, and to assume 12

30 POINT POSTER LINING ROMAN NO 153

5 A 3 A 7 a 84 60

DESIRE FREEDOM

WHEN, in time, it becomes needful for one people to dissolve 84

Twenty-five pounds and multiples at Roman prices, complete with figures, fractions, and spaces and quads

36 POINT POSTER LINING ROMAN NO 153

4 A 3 A 5 a \$5 50

DISCONTENTS
 WHEN, in time, it
 is needful for 572

48 POINT POSTER LINING ROMAN NO 153

4 A 5 a \$7 50

REPORTED
 When, in this
 year of our 18

*Twenty-five pounds and multiples at Roman prices, complete with figures, fractions,
 and spaces and quads*

ROMAN No 44

60 POINT ROMAN NO 44

4 A 4 a \$8 95

RESIDE
 Declare 6

POSTER ROMAN SERIES No 123

* 12 POINT POSTER ROMAN No 123

12 A 24a \$2 00

NOBLE INDEPENDENCE SIGNERS
WHEN, in the course of human events,
it becomes necessary for one people
to dissolve the political bands which
have connected them with another,
and to assume, among the powers of

* 18 POINT POSTER ROMAN No 123

12 A 24a \$4 00

COLONIAL GOVERNMENT
WHEN, in the course of human
events, it becomes necessary
for one people to dissolve the
political bands which have

* 24 POINT POSTER ROMAN No 123

10 A 20a \$4 00

REVOLUTION FATHER
WHEN, in the course of
human events, it should
become necessary for a

* 30 POINT POSTER ROMAN No 123

6 A 12a \$5 25

NOBLE SIGNERS
WHEN, through the
natural courses of

*Twenty-five pounds and multiples at Roman prices, complete with figures, fractions,
 and spaces and quads*

OLD STYLE ROMAN SERIES No 83

5 POINT OLD STYLE NO 79

WHEN, in the course of human events, it becomes necessary for one people to dissolve the political bands which have connected them with another, and to assume, among the powers of the earth, the separate and equal station to which the laws of nature and of nature's God entitle them, a decent respect to the *opinions of mankind requires that* they should declare the causes which impel them to the separation. We hold these truths to be self-evident, that all men are created equal; that they are endowed by their Creator with certain unalienable rights; that among these, are life, liberty, and

Lower case a to z, 14½ ems

ABCDEFGHIJKLMNQPQRSTUVWXYZ

1234567890

5½ POINT OLD STYLE NO 80

WHEN, in the course of human events, it becomes necessary for one people to dissolve the political bands which have connected them with another, and to assume, among the powers of the earth, the separate and equal station to which the laws of nature and of nature's God entitle them, a decent respect to the opinions of mankind requires that they should declare the causes which impel them to the separation. We hold these truths to be self-evident, that all men are created equal; that they are en-

Lower case a to z, 14¾ ems

ABCDEFGHIJKLMNQPQRSTUVWXYZ

1234567890

6 POINT OLD STYLE NO 83

WHEN, in the course of human events, it becomes necessary for one people to dissolve the political bands which have connected them with another, and to assume, among the powers of the earth, the separate and equal station to which the laws of nature and of nature's God entitle them, a decent respect to the opinions of mankind requires that they should declare the causes which impel them to the separation. We hold these truths to be self-evident, that all men are created equal; that they are endowed by their Creator with certain unalienable rights; that among these, are life, liberty, and the pursuit of happiness. That, to secure these rights, governments are instituted among men, *deriving their just powers from the* consent of the governed; that, whenever any government becomes destructive of these ends, it is

Lower case a to z, 15¼ ems

ABCDEFGHIJKLMNQPQRSTUVWXYZ

1234567890

7 POINT OLD STYLE NO 83

WHEN, in the course of human events, it becomes necessary for one people to dissolve the political bands which have connected them with another, and to assume, among the powers of the earth, the separate and equal station to which the laws of nature and of nature's God entitle them, a decent respect to the opinions of mankind requires that they should declare the causes which impel them to the separation. We hold these truths to be self-evident, that all men are created equal; *that they are endowed by their Creator with* certain unalienable rights; that among these, are life, liberty, and the pursuit of happiness. That, to secure these rights, governments are instituted among

Lower case a to z, 14 ems

ABCDEFGHIJKLMNQPQRSTUVWXYZ

1234567890

8 POINT OLD STYLE NO 83

WHEN, in the course of human events, it becomes necessary for one people to dissolve the political bands which have connected them with another, and to assume, among the powers of the earth, the separate and equal station to which the laws of nature and of nature's God entitle them, a decent respect to the opinions of mankind requires that they should *declare the causes which impel* them to the separation. We hold these truths to be self-evident, that all men are created equal; that they are endowed by their Creator with cer-

Lower case a to z, 14 ems

ABCDEFGHIJKLMNQPQRSTUVWXYZ

1234567890

9 POINT OLD STYLE NO 83 12

WHEN, in the course of human events, it becomes necessary for one people to dissolve the political bands which have connected them with another, and to assume, among the powers of the earth, the separate and equal station to which the laws of nature and of nature's God entitle them, a decent respect to the opinions of mankind requires that they should declare the causes which impel them to the separation. We hold these truths to be self-evident, *that all men are created equal*; that they are endowed by their Creator with certain unalienable rights; that, among these, are life, liberty, and the pursuit of happiness. That, to secure these rights, governments are instituted

Lower case a to z, 13½ ems

ABCDEFGHIJKLMNOPQRSTUVWXYZ

1234567890

10 POINT OLD STYLE NO 83 12

WHEN, in the course of human events, it becomes necessary for one people to dissolve the political bands which have connected them with another, and to assume, among the powers of the earth, the separate and equal station to which the laws of nature and of nature's God entitle them, a decent respect to the opinions of mankind requires that they should *declare the causes which impel* them to the separation. We hold these truths to be self-evident, that all men are created equal; that they are endowed by their Creator with certain unalienable rights; that among these,

Lower case a to z, 13½ ems

ABCDEFGHIJKLMNOPQRSTUVWXYZ

1234567890

11 POINT OLD STYLE NO 83 12

WHEN, in the course of human events, it becomes necessary for one people to dissolve the political bands which have connected them with another, and to assume, among the powers of the earth, the separate and equal station to which the laws of nature and of nature's God entitle them, a decent respect to the *opinions of mankind requires* that they should declare the causes which impel them to the separation. We hold these truths to be self-evident,

Lower case a to z, 13½ ems

ABCDEFGHIJKLMNOPQRSTUVWXYZ

1234567890

12 POINT OLD STYLE NO 83 12

WHEN, in the course of human events, it becomes necessary for one people to dissolve the political bands which have connected them with another, and to assume, among the powers of the earth, the separate and equal station to which the laws of nature and of nature's God entitle them, a decent respect to the opinions of mankind requires that they should declare *the causes which impel* them to the separation. We hold these truths to be self-evident, that all men are created equal; that they are endowed by their Creator with certain unalienable rights; that among these are life, liberty, and the pursuit of happiness.

Lower case a to z, 14 ems

ABCDEFGHIJKLMNQRSTU

1234567890

18 POINT OLD STYLE NO 83 12

ITALIC 10A 20a \$3 10

8A \$0 55

10A 20a \$2 95

WHEN, in the course of human events, it becomes necessary for one people to dissolve the political bands which have connected them with another, and to assume, among the powers of the earth, the separate *and equal station* to which the laws of nature and of nature's God entitle them, a decent respect to the opinions of mankind requires that they

ABCDEFGHIJKLMN

1234567890

22 POINT OLD STYLE NO 83 "

ITALIC 8 A 16 a \$3 80 6 A \$0 75 8 A 16 a \$3 50

SOLID GOVERNMENTS

When, in the course of events it becomes *necessary* for one people to dissolve the political bands which have connected them with another, it

24 POINT OLD STYLE NO 83 "

ITALIC 8 A 16 a \$4 25 6 A \$0 95 8 A 16 a \$4 75

PROUD REPUBLIC

When, in the course of human events, it first becomes *necessary* for one people to dissolve political bands which always

30 POINT OLD STYLE NO 83 "

ITALIC 5 A 10 a \$5 00 4 A \$1 00 6 A 12 a \$5 60

OUR REPUBLIC

When, in the course of *human* events, it becomes necessary

42 POINT OLD STYLE NO 83 12

ITALIC 3 A 6a \$6 00 3 A 6a \$6 05

DECLARED
When learned
men believe in
a necessity *for*
the country to

60 POINT OLD STYLE NO 83 12

3 A 6a \$10 25

HEROES
When, in a
country the
noble men

OLD STYLE ROMAN SERIES NO 82

— 15

6 POINT OLD STYLE NO 82

WHEN, in the course of human events, it becomes necessary for one people to dissolve the political bands which have connected them with another, and to assume, among the powers of the earth, the separate and equal station to which the laws of nature and of nature's God entitle them, a decent respect to the opinions of mankind requires *that they should declare the causes* which impel them to the separation. We hold these truths to be self-evident, that all men are created equal; that they are endowed by their Creator with certain unalienable rights; that among these, are life, liberty, and the pursuit of happiness. That, to secure these rights, governments are instituted among men, deriving their just powers from the consent of the governed; that, whenever any form of government becomes destructive of these ends, it is the right of the people to alter or to abolish it, and to institute a new government, laying its foundation on such principles, and organizing its powers in such form, as to them shall seem most likely to effect their safety

Lower case a to z, 13 $\frac{3}{4}$ ems

ABCDEFGHIJKLMNOPQRSTUVWXYZ

1234567890

7 POINT OLD STYLE NO 82

WHEN, in the course of human events, it becomes necessary for one people to dissolve the political bands which have connected them with another, and to assume, among the powers of the earth, the separate and equal station to which the laws of nature and of nature's God entitle them, a decent respect to the opinions of mankind requires that they should declare the causes which impel them to the separation. We hold these truths to be self-evident, that all men are created equal; that they are endowed by their Creator with certain unalienable rights; that among these, are life, liberty, and the pursuit of happiness. That, to secure these rights, governments are instituted among men, deriving their just powers from the consent of the governed;

Lower case a to z, 13 $\frac{1}{4}$ ems

ABCDEFGHIJKLMNOPQRSTUVWXYZ

1234567890

8 POINT OLD STYLE NO 82

WHEN, in the course of human events, it becomes necessary for one people to dissolve the political bands which have connected them with another, and to assume, among the powers of the earth, the separate and equal station to which the laws of nature and of nature's God entitle them, *a decent respect to the opinions of mankind requires* that they should declare the causes which impel them to the separation. We hold these truths to be self-evident, that all men are created equal; that they are endowed by their Creator with certain unalienable rights; that among these, are life, liberty, and the pursuit

Lower case a to z, 12 $\frac{1}{2}$ ems

ABCDEFGHIJKLMNOPQRSTUVWXYZ

1234567890

9 POINT OLD STYLE NO 82

WHEN, in the course of human events, it becomes necessary for one people to dissolve the political bands which have connected them with another, and to assume, among the powers of the earth, *the separate and equal station to which the laws* of nature and of nature's God entitle them, a decent respect to the opinions of mankind requires that they should declare the causes which impel them to the separation. We hold these truths to be self-evident, that all men are created equal: that

Lower case a to z, 12 ems

ABCDEFGHIJKLMNOPQRSTUVWXYZ

1234567890

10 POINT OLD STYLE NO 82

WHEN, in the course of human events, it becomes necessary for one people to dissolve the political bands which have connected them with another, and to assume, among the powers of the earth, the separate and equal station to which the laws of nature and of nature's God entitle them, a decent respect to the opinions of *mankind requires that they should declare the causes* which impel them to the separation. We hold these truths to be self-evident, that all men are created equal; that they are endowed by their Creator with certain unalienable rights; that among these, are life, liberty, and the pursuit of happiness. That, to secure these rights, governments are instituted among men, deriving their just

Lower case a to z, 11¾ ems

ABCDEFGHIJKLMNOPQRSTUVWXYZ

1234567890

11 POINT OLD STYLE NO 82

WHEN, in the course of human events, it becomes necessary for one people to dissolve the political bands which have connected them with another, and to assume, among the powers of the earth, the separate and equal station to which the laws of nature and of nature's God entitle them, a decent *respect to the opinions of mankind requires* that they should declare the causes which impel them to the separation. We hold these truths to be self-evident, that all men are created equal; that they are endowed by their Creator with certain unalienable rights; that among these, are life, liberty, and the

Lower case a to z, 11¾ ems

ABCDEFGHIJKLMNOPQRSTUVWXYZ

1234567890

12 POINT OLD STYLE NO 82

WHEN, in the course of human events, it becomes necessary for one people to dissolve the political bands which have connected them with another, and to assume, among the powers of the earth, the separate and equal station to *which the laws of nature and of nature's* God entitle them, a decent respect to the opinions of mankind requires that they should declare the causes which impel them to the separation. We hold these truths to be self-evident, that all men are created equal;

Lower case a to z, 12 ems

ABCDEFGHIJKLMNOPQRSTUVWXYZ

1234567890

BARTH SERIES No 74

6 POINT OLD STYLE No 74

WHEN, in the course of human events, it becomes necessary for one people to dissolve the political bands which have connected them with another, and to assume, among the powers of the earth, the separate and equal station to which the laws of nature and of nature's God entitle them, a decent respect to the opinions of mankind requires that they should declare the causes which impel them to the separation. We hold these truths to be self-evident, that all men are created equal: that they are endowed by their Creator with certain unalienable rights; that among these, are life, liberty, and the pursuit of happiness. That, to secure these rights, governments are instituted among men, deriving their just powers from the consent of the governed; that, whenever any form of government becomes destructive of these ends, it is the right of the people to alter or to abolish it, and to institute a new government, laying its foundation on such principles, and organizing its powers in such form, as to them shall seem most likely to effect their safety and happiness. Prudence, indeed, will dictate that governments long established, should not be changed for light and transient causes; and, accordingly, all experience hath shown, that mankind are more

Lower case a to z, 16 ems

ABCDEFGHIJKLMN^{OP}QRSTU^{VW}XYZ

1234567890

8 POINT OLD STYLE No 74

WHEN, in the course of human events, it becomes necessary for one people to dissolve the political bands which have connected them with another, and to assume, among the powers of the earth, the separate and equal station to which the laws of nature and of nature's God entitle them, a decent respect to the opinions of mankind requires that they should declare the causes which impel them to the separation. *We hold these truths to be self-evident, that all men are created equal; that they are endowed by their Creator with certain unalienable rights; that among these, are life, liberty, and the pursuit of happiness. That, to secure these rights, governments are instituted among men, deriving their just powers from the consent of the governed; that, whenever any form of government becomes destructive of these ends, it is the right of the people to alter or to abolish it, and to institute a*

Lower case a to z, 13½ ems

ABCDEFGHIJKLMN^{OP}QRSTU^{VW}XYZ

1234567890

10 POINT OLD STYLE No 74

WHEN, in the course of human events, it becomes necessary for one people to dissolve the political bands which have connected them with another, and to assume, among the powers of the earth, the separate and equal station to which the laws of nature and of nature's God entitle them, a decent respect to the opinions of *mankind requires that they should declare* the causes which impel them to the separation. We hold these truths to be self-evident, that all men are created equal; that they are endowed by their Creator with certain unalienable rights; that among these, are life, liberty, and the pursuit of happiness. That, to secure these rights, governments are

Lower case a to z, 11 ems

ABCDEFGHIJKLMN^{OP}QRSTU^{VW}XYZ

1234567890

11 POINT OLD STYLE NO 74

WHEN, in the course of human events, it becomes necessary for one people to dissolve the political bands which have connected them with another, and to assume, among the powers of the earth, the separate and equal station to which the laws of nature and of nature's God entitle them, a decent respect to the opinions of mankind requires that they should declare the causes which impel them to the separation. *We hold these truths to be self-evident*, that all men are created equal; that they are endowed by their Creator with certain unalienable rights; that among these, are life, liberty, and the pursuit of happiness. That, to secure these rights, governments are instituted among men, deriving their just powers from the consent of the governed; that, whenever any form of government becomes destructive of these ends, it is the right of the people to alter or to abolish it, and to institute a new government, laying its foundation on such

Lower case a to z, 13 ems

ABCDEFGHIJKLMNPOQRSTUVWXYZ

1234567890

12 POINT OLD STYLE NO 74

WHEN, in the course of human events, it becomes necessary for one people to dissolve the political bands which have connected them with another, and to assume, among the powers of the earth, the separate and equal station to which the laws of nature and of nature's God entitle them, a decent respect to the opinions of mankind requires that they should declare the causes which impel them to the separation. *We hold these truths to be self-evident*, that all men are created equal; that they are endowed by their Creator with certain unalienable rights; that among these, are life, liberty, and the pursuit of happiness. That, to secure these rights, governments are instituted among men, deriving their just powers from the consent of the governed; that whenever any form of government becomes destructive of

Lower case a to z, 13 ems

ABCDEFGHIJKLMNPOQRSTUVWXYZ

1234567890

RONALDSON SERIES No 72

6 POINT OLD STYLE No 72

WHEN, in the course of human events, it becomes necessary for one people to dissolve the political bands which have connected them with another, and to assume, among the powers of the earth, the separate and equal station to which the laws of nature and of nature's God entitle them, a decent respect to the *opinions of mankind* requires that they should declare the causes which impel them to the separation. We hold these truths to be self-evident, that all men are created equal; that they are endowed by their Creator with certain unalienable rights; that among these, are life, liberty, and the pursuit of happiness. That, to secure these rights, governments are instituted among men, deriv-

ing their just powers from the consent of the governed; that, whenever any form of government becomes destructive of these ends, it is the right of the people to alter or to abolish it, and to institute a new government, laying its foundation on such principles, and organizing its powers in such form, as to them shall seem most likely to effect their safety and happiness. *Prudence, indeed, will dictate* that governments long established, should not be changed for light and transient causes; and, accordingly, all experience hath shown, that mankind are more disposed to suffer, while evils are sufferable, than to right themselves by abolishing the forms to which they are accustomed.

Lower case a to z, 15½ ems

ABCDEFGHIJKLMN OPQRSTU VWXYZ

1234567890

7 POINT OLD STYLE No 72

WHEN, in the course of human events, it becomes necessary for one people to dissolve the political bands which have connected them with another, and to assume, among the powers of the earth, the separate and equal station to which the laws *of nature and of nature's God* entitle them, a decent respect to the opinions of mankind requires that they should declare the causes which impel them to the separation. We hold these truths to be self-evident, that all men are created equal; that they are endowed by their Creator

with certain unalienable rights; that among these, are life, liberty, and the pursuit of happiness. That, to secure these rights, governments are instituted among men, deriving their just *powers from the consent* of the governed; that, whenever any form of government becomes destructive of these ends, it is the right of the people to alter or to abolish it, and to institute a new government, laying its foundation on such principles, and organizing its powers in such form, as to them shall seem most likely to effect their

Lower case a to z, 14¾ ems

ABCDEFGHIJKLMN OPQRSTU VWXYZ

1234567890

8 POINT OLD STYLE No 72

WHEN, in the course of human events, it becomes necessary for one people to dissolve the political bands which have connected them with another, and to assume, among the powers of the earth, the separate and equal station to which the laws of nature and of nature's God entitle them, a decent respect to the opinions of mankind requires that they should declare the causes which impel them to the separation. *We hold these truths to be self-evident*, that all men are created equal; that they are endowed by their Creator with certain unalienable rights; that among these, are life, liberty, and the pursuit of happiness. That, to secure these rights, governments are instituted among men, deriving their just powers from the consent of the governed; that, whenever any form of government becomes destructive of these ends, it is the right of the people to alter or to abolish it, and to institute a new government,

Lower case a to z, 14 ems

ABCDEFGHIJKLMN OPQRSTU VWXYZ

1234567890

9 POINT OLD STYLE NO 72

WHEN, in the course of human events, it becomes necessary for one people to dissolve the political bands which have connected them with another, and to assume, among the powers of the earth, the separate and equal station to which the laws of nature and of nature's God entitle them, a decent respect to the opinions of mankind requires that they should declare the causes which impel them to the separation. We hold these truths to be self-evident, that all men are created equal; that they are endowed by their Creator with certain unalienable rights; that among these, are life, liberty, and the pursuit of happiness. That, to secure these rights, *governments are instituted among men*, deriving their just powers from the consent of the governed; that, whenever any form of government becomes destructive of these ends, it is the right of the people to alter or to abolish it, and to institute a new government, laying its foundation on such principles, and organizing its powers in such form, as to them shall seem most likely to effect their safety and happiness. Prudence, indeed, will dictate that governments long established, should not be changed for light and transient causes; and, accordingly, all experience hath shown, that mankind are more disposed to suffer, while evils are sufferable, than to right themselves by abolishing the forms to which they

Lower case a to z, 13½ ems

ABCDEFGHIJKLMNOPQRSTUVWXYZ

1234567890

10 POINT OLD STYLE NO 72

WHEN, in the course of human events, it becomes necessary for one people to dissolve the political bands which have connected them with another, and to assume, among the powers of the earth, the separate and equal station to which the laws of nature and of nature's God entitle them, a decent respect to the opinions of mankind requires that they should declare the causes which impel them to the separation. We hold these truths to be self-evident, that all men are created equal; *that they are endowed by their Creator* with certain unalienable rights; that among these, are life, liberty, and the pursuit of happiness. That, to secure these rights, governments are instituted among men, deriving their just powers from the consent of the governed; that, whenever any form of government becomes destructive of these ends, it is the right of the people to alter or to abolish it, and to institute a new government, laying its foundation on such principles, and organizing its powers in such form, as to them shall seem most likely to effect their safety and happiness. Prudence, indeed, will dictate that governments long established, should not be

Lower case a to z, 14 ems

ABCDEFGHIJKLMNOPQRSTUVWXYZ

1234567890

11 POINT OLD STYLE NO 72

WHEN, in the course of human events, it becomes necessary for one people to dissolve the political bands which have connected them with another, and to assume, among the powers of the earth, the separate and equal station to which the laws of nature and of nature's God entitle them, a decent respect to the opinions of mankind requires that they should declare the causes which impel them to the separation. We hold these truths to be self-evident, that all men are created equal; *that they are endowed by their Creator with certain unalienable rights; that among these, are life, liberty, and the pursuit of happiness.* That, to secure these rights, governments are instituted among men, deriving their just powers from the consent of the governed; that, whenever any form of government becomes destructive of these ends, it is the right of the people to alter or to abolish it, and to institute a new government, laying its foundation on such principles, and organizing

Lower case a to z, 12½ ems

ABCDEFGHIJKLMNOPQRSTUVWXYZ

1234567890

12 POINT OLD STYLE NO 72

WHEN, in the course of human events, it becomes necessary for one people to dissolve the political bands which have connected them with another, and to assume, among the powers of the earth, the separate and equal station to which the laws of nature and of nature's God entitle them, a decent respect to the opinions of mankind requires that they should declare the causes which impel them to the separation. *We hold these truths to be self-evident,* that all men are created equal; that they are endowed by their Creator with certain unalienable rights; that among these, are life, liberty, and the pursuit of happiness. That, to secure these rights, governments are instituted among men, deriving their just powers from the consent of the governed; that, whenever any form of government becomes destruc-

Lower case a to z, 12½ ems

ABCDEFGHIJKLMNOPQRSTUVWXYZ

1234567890

15 POINT OLD STYLE NO 72

12 A 6 A 40 a 84 55

DECLARED OUR INDEPENDENCE
WHEN, in the course of human events, it becomes necessary for one people to dissolve the political bands which have connected them with another, and to assume, among the powers of the earth, the separate and equal station to which the laws of nature and of nature's God entitle them, a decent respect to the opinions of mankind

18 POINT OLD STYLE NO 72

14 A 30 a 84 30

PROCLAMATION OF RIGHTS
When, in the course of human events, it becomes necessary for one people to dissolve the political bands which have connected them with another, and to assume, among the powers of the earth, the equal station to which

24 POINT OLD STYLE NO 72

10 A 20 a 84 70

BENJAMIN FRANKLIN
When, in the course of time, it becomes necessary for one people to dissolve the political bands which have united them with another, a decent

30 POINT OLD STYLE NO 72

8 A 16 a \$5 85

TRUE SENTENCES
When, in the course of
events, it becomes the
sad duty for one people

36 POINT OLD STYLE NO 72

8 A 12 a \$7 00

LIBERAL IDEAS
When, in the course
of human events, it
is necessary for one

48 POINT OLD STYLE NO 72

5 A 8 a \$8 00

CELEBRATE
When, through
natural causes,

CASLON OLD STYLE NO 71

Old English characters, as under, furnished for all sizes when specially ordered as additions to regular fonts

Æ f ff fb fh fi ffi fk fl fl ft

This face was cut in 1722, and is the oldest type face now in use in the United States. It has survived on account of very exceptional merit, and is more popular to-day than at any period since the introduction of the Modern Roman face.

6 POINT OLD STYLE NO 71 25 A 15 A 170 a 86 95

WHEN, in the course of human events, it becomes necessary for one people to dissolve the political bands which have connected them with another, and to assume, among the powers of the earth, the separate and equal station to which the laws of nature and of nature's God entitle them, a decent respect to the opinions of mankind requires that they should declare the causes which impel them to the separation. *We hold these truths to be self-evident*, that all men are created equal; that they are endowed by their Creator with certain unalienable rights; that among these, are life, liberty, and the pursuit of happiness. That, to secure these rights, governments are instituted among men, deriving their just powers from the consent of the

Lower case a to z, 13½ ems

ABCDEFGHIJKLMN OPQRSTUVWXYZ

1234567890

8 POINT OLD STYLE NO 71 20 A 12 A 120 a 85 40

WHEN, in the course of human events, it becomes necessary for one people to dissolve the political bands which have connected them with another, and to assume, among the powers of the earth, the separate and equal station to which the laws of nature and of nature's God entitle them, a decent respect to the opinions of mankind requires that they should declare the causes which impel them to the separation. *We hold these truths to be self-evident*, that all men are created equal; that they

Lower case a to z, 11½ ems

ABCDEFGHIJKLMN OPQRSTUVWXYZ

1234567890

9 POINT OLD STYLE NO 71

18 A 9 A 90 a 84 80

WHEN, in the course of human events, it becomes necessary for one people to dissolve the political bands which have connected them with another, and to assume, among the powers of the earth, the separate and equal station to which the laws of nature and of nature's God entitle them, a decent respect to the opinions of mankind requires that they should declare the causes which impel them to the separation. *We hold these truths to be self-evident*, that all men are created equal; that they are endowed by their Creator with certain unalienable rights; that among these, are life, liberty, and the pursuit of happiness. That, to secure these rights, governments are instituted among men, deriving their just powers from the consent of the

Lower case a to z, 11 2-5 ems

ABCDEFGHIJKLMN OPQRSTUVWXYZ

1234567890

10 POINT OLD STYLE NO 71

15 A 8 A 75 a 84 45

WHEN, in the course of human events, it becomes necessary for one people to dissolve the political bands which have connected them with another, and to assume, among the powers of the earth, the separate and equal station to which the laws of nature and of nature's God entitle them, a decent respect to the opinions of mankind requires that they should declare the causes which impel them to the separation. *We hold these truths to be self-evident*, that all men are created equal; that they are endowed by their Creator with certain unalienable rights;

Lower case a to z, 11¼ ems

ABCDEFGHIJKLMN OPQRSTUVWXYZ

1234567890

11 POINT OLD STYLE NO 71

14A 7A 70a 84 20

WHEN, in the course of human events, it becomes necessary for one people to dissolve the political bands which have connected them with another, and to assume, among the powers of the earth, the separate and equal station to which the laws of nature and of nature's God entitle them, a decent respect to *the opinions of mankind requires that they* should declare the causes which impel them to the separation. We hold these truths to be self-evident, that all men are created equal; that they are endowed by their Creator with certain unalienable rights; that among these, are life, liberty, and the pursuit of happiness.

Lower case a to z, 11¼ ems

ABCDEFGHIJKLMN OPQRSTUVWXYZ

1234567890

12 POINT OLD STYLE NO 71

12A 6A 60a 84 60

WHEN, in the course of human events, it becomes necessary for one people to dissolve the political bands which have connected them with another, and to assume, among the powers of the earth, the separate and equal station to which *the laws of nature and of nature's God* entitle them, a decent respect to the opinions of mankind requires that they should declare the causes which impel them to the separation. We hold these truths to be self-evident, that all men are created equal; that

Lower case a to z, 11 5/8 ems

ABCDEFGHIJKLMN OPQRSTUVWXYZ

1234567890

14 POINT OLD STYLE NO 71

18A 14A 52a 85 25

WHEN, in the course of human events, it becomes necessary for one people to dissolve the political bands which have connected them with another, and to assume, *among the powers of the earth*, the separate and equal station to which the laws of nature and of nature's God entitle them, a decent respect to the opinions of mankind requires that

ABCDEFGHIJKLMN OPQRSTUVWXYZ

1234567890

18 POINT OLD STYLE NO 71

18 A 14 A 52 a \$8 30

LOVING FREEDOM AND HONOR
WHEN, in the course of human events,
it becomes necessary for one people to
dissolve the political bands which have
connected them with another, and to
assume, among the powers of the earth,
the separate and equal station to 2587

22 POINT OLD STYLE NO 71

14 A 10 A 28 a \$7 65

DESIRED BY THE PEOPLE
WHEN, in the course of human
events, it becomes necessary for
one people to dissolve the political
bands which have connected them
with another, and to assume 408

24 POINT OLD STYLE NO. 71

10 A 7 A 20 a \$7 65

ADVENT OF LIBERTY
WHEN, in the course of time,
it becomes necessary for one
people to dissolve the political
bands which have connected
them with another, and to 56

28 POINT OLD STYLE NO 71

7 A 4 A 14 a 86 95

RESOLUTE SIGNERS
WHEN, in course of time,
it becomes necessary for
one people to break the

36 POINT OLD STYLE NO 71

7 A 4 A 14 a 86 35

NOTED WRITER
WHEN, in the course
of human events, it
becomes needful for

40 POINT OLD STYLE NO 71

5 A 10 a 88 35

CONTENTED
When, in course
of human events
it becomes most

48 POINT OLD STYLE NO 71

4A 6a \$8 50

AMERICAN
Liberty reigns
Fourth of July

60 POINT OLD STYLE NO 71

3A 4a \$10 45

SALUTE
Old Glory

72 POINT OLD STYLE NO 71

3A 3a \$14 05

SONGS
Patriotic

CASLON OLD STYLE ITALIC No 71

This series was cut A. D. 1722

48 POINT

8 A 5 a \$6 05

REFORMS
Honorable Intention

22 POINT

8 A 18 a \$3 15

MUNICIPAL TAXPAYERS
The impartial observer of the subject
quickly discovers that a Movement to
Push the Growth of the Town is felt

18 POINT

10 A 28 a \$3 40

ELECTRIC LIGHT FRANCHISE
Important Privileges were granted by the
Board of Aldermen, who did not hesitate to
surrender without Restraint one of the most
valuable Rights in the City to a Syndicate

26 POINT

5 A 10 a \$3 60

OLD COLORIST
Chromatic Sketchings Exhibited
Beautiful Design

40 POINT OLD STYLE ITALIC NO 71

4 A 7 a \$5 15

DEFINING
Agrarian Legislation

24 POINT OLD STYLE ITALIC NO 71

6 A 14 a \$3 35

DECISIONS RENDERED
Sanitary Authorities refused the
overtures of the property owners
for severe Quarantine Measures

14 POINT OLD STYLE ITALIC NO 71

18 A 52 a \$5 00

STATE AND COUNTY GOVERNMENTS
We have a system of Local Government equal to any
which exists in Europe. The Legislatures have power
little short of Home Rule, and the Townships exercise
considerable Legislative Rights under various charters
that are augmented in accordance with the development

36 POINT OLD STYLE ITALIC NO 71

4 A 8 a \$4 50

ENORMOUS
Monetary Consideration
Short Debate

FRENCH OLD STYLE No 2 ITALIC

This Italic lines with French Old Style No. 2. Italic of same face, to line with French Elzevir, supplied at prices listed on pages 140 and 141

6 POINT

20 A 45 a \$2 25

7 POINT

24 A 60 a \$2 50

When, in the course of human events, it becomes necessary for one people to dissolve the political bands which have connected them with another, and to assume, among the powers of the earth, the separate and equal station to which the laws of nature and of nature's God entitle them, a decent respect to the opinions of mankind requires that they should

ABCDEFGHIJKLMNPOQRSTUVWXYZ

1234567890

When, in the course of human events, it becomes necessary for one people to dissolve the political bands which have connected them with another, and to assume, among the powers of the earth, the separate and equal station to which the laws of nature and of nature's God

ABCDEFGHIJKLMNPOQRSTUVWXYZ

1234567890

8 POINT

24 A 60 a \$2 75

When, in the course of human events, it becomes necessary for one people to dissolve the political bands which have connected them with another, and to assume, among the powers of the earth, the separate and equal station to which the laws of nature and of nature's God entitle them, a decent respect to the opinions of mankind requires that they should declare the causes which impel them to the separa-

ABCDEFGHIJKLMNPOQRSTUVWXYZ

1234567890

10 POINT

20 A 50 a \$3 00

When, in the course of human events, it becomes necessary for one people to dissolve the political bands which have connected them with another, and to assume, among the powers of the earth, the separate and equal station to which the laws of nature and of

ABCDEFGHIJKLMNPOQRSTUVWXYZ

1234567890

12 POINT

16 A 40 a \$3 50

When, in the course of human events, it becomes necessary for one people to dissolve the political bands which have connected them with another, and to assume, among the powers of the earth, the separate and

ABCDEFGHIJKLMNPOQRSTUVWXYZ

1234567890

14 POINT ELZEVR ITALIC

16 A 36 a \$3 90

When, in the course of human events, it becomes necessary for one people to dissolve the political bands which have connected them with another,

ABCDEFGHIJKLMNPOQRSTUVWXYZ

1234567890

FRENCH OLD STYLE No 2

6 POINT

30 A 81 25 30 A 20 A 100 a 84 00

WHEN, in the course of human events, it becomes necessary for one people to dissolve the political bands which have connected them with another, and to assume, among the powers of the earth, the separate and equal station to which the laws of nature and of nature's God entitle them, a decent respect to the opinions of mankind requires that they should declare the causes which impel them to the separation. We hold these truths to be self-evident, that all men are created equal; that they are endowed by their Creator with certain unalienable rights; that among these, are life, liberty, and the pursuit of happiness. That, to secure these rights, governments are instituted among men, deriving their just powers from the consent of the governed; that, whenever any form of government becomes destruc-

tive of these ends, it is the right of the people to alter or to abolish it, and to institute a new government, laying its foundation on such principles, and organizing its powers in such form, as to them shall seem most likely to effect their safety and happiness. Prudence, indeed, will dictate that governments long established, should not be changed for light and transient causes; and, accordingly, all experience hath shown, that mankind are more disposed to suffer, while evils are sufferable, than to right themselves by abolishing the forms to which they are accustomed. But, when a long train of abuses and usurpations, pursuing invariably the same object, evinces a design to reduce

Lower case a to z, 14 ems

ABCDEFGHIJKLMNQPQRSTUVWXYZ

1234567890

7 POINT

30 A 81 60 30 A 15 A 90 a 84 00

WHEN, in the course of human events, it becomes necessary for one people to dissolve the political bands which have connected them with another, and to assume, among the powers of the earth, the separate and equal station to which the laws of nature and of nature's God entitle them, a decent respect to the opinions of mankind requires that they should declare the causes which impel them to the separation. We hold these truths to be self-evident, that all men are created equal; that they are endowed by their Creator with certain unalienable rights; that among these, are life, liberty, and the pursuit of happiness. That, to secure these rights, governments are instituted among men, deriving their just powers from the consent of the governed; that, whenever any form of government becomes destructive of these ends, it is the right of the people to alter or to abolish it, and to institute a new government, laying its foundation on such principles, and organizing its powers in such form, as to them shall

Lower case a to z, 14½ ems

ABCDEFGHIJKLMNQPQRSTUVWXYZ

1234567890

8 POINT

30 A 81 65 30 A 15 A 90 a 84 00

WHEN, in the course of human events, it becomes necessary for one people to dissolve the political bands which have connected them with another, and to assume, among the powers of the earth, the separate and equal station to which the laws of nature and of nature's God entitle them, a decent respect to the opinions of mankind requires that they should declare the causes which impel them to the separation. We hold these truths to be self-evident, that all men are created equal; that they are endowed by their Creator with certain unalienable rights; that among these, are life, liberty, and the pursuit of happiness. That, to secure these rights, governments are instituted among men, deriving their just powers from the consent of the governed; that, whenever any form of

Lower case a to z, 13¾ ems

ABCDEFGHIJKLMNQPQRSTUVWXYZ

1234567890

10 POINT FRENCH OLD STYLE No 2

24 A \$1 60

24 A 12 A 75 a \$4 70

WHEN, in the course of human events, it becomes necessary for one people to dissolve the political bands which have connected them with another, and to assume, among the powers of the earth, the separate and equal station to which the laws of nature and of nature's God entitle them, a decent respect to the opinions of mankind requires that they should declare the causes which impel them to the separation. We hold these truths to be self-evident, that all men are created equal; that they are endowed by their Creator with certain unalienable rights; that among these, are life, liberty, and the pursuit of happiness. That, to secure these rights, governments are instituted among men, deriving their just powers from the consent of the governed; that, whenever any form of government becomes destructive of these ends, it is the right of the people to alter or to abolish it, and to institute a new government, laying its foundation on such principles, and organizing

Lower case a to z. 12¾ ems

ABCDEFGHIJKLMN OPQRSTUVWXYZ

1234567890

12 POINT FRENCH OLD STYLE No 2

20 A \$1 55

20 A 10 A 60 a \$5 00

WHEN, in the course of human events, it becomes necessary for one people to dissolve the political bands which have connected them with another, and to assume, among the powers of the earth, the separate and equal station to which the laws of nature and of nature's God entitle them, a decent respect to the opinions of mankind requires that they should declare the causes which impel them to the separation. We hold these truths to be self-evident, that all men are created equal; that they are endowed by their Creator with certain unalienable rights; that among these, are life, liberty, and the pursuit of happiness. That, to secure these rights, governments are instituted among men, de-

Lower case a to z. 13 ems

ABCDEFGHIJKLMN OPQRSTUVWXYZ

1234567890

18 POINT FRENCH OLD STYLE No 2

18 A \$2 50 18 A 36 a \$5 00

DECLARED OUR INDEPENDENCE

When, in the course of human events, it becomes necessary for one people to dissolve the political bands which have connected them with another, and to assume, among the powers, the equal and separate station to which the laws of nature and of nature's God entitle them, a decent respect to the opinions of mankind requires that they should declare the causes which impel them to the separation. We hold 789024

20 POINT FRENCH OLD STYLE No 2

14 A \$2 70 14 A 28 a \$5 50

PROCLAIM OUR RIGHTS

When, in the course of human events, it becomes necessary for one people to dissolve the bands which have connected them with another, and to assume, among the powers, the separate and equal station to which the laws of nature and of nature's God entitle 1 2 3 4 5 6

24 POINT FRENCH OLD STYLE NO 2

10 A \$2 80

10 A 20 a \$5 75

TRUE GOVERNMENT
 When, in the course of
 time, it became the sad
 duty for one people to
 dissolve the bands 260

30 POINT FRENCH OLD STYLE NO 2

7 A \$2 90

7 A 12 a \$5 75

HAIL COLUMBIA!
 When, in the course
 of human events, it
 will be necessary 65

36 POINT FRENCH OLD STYLE NO 2

5 A \$3 00

5 A 9 a \$6 00

SOUND FACTS
 When a natural
 cause forces the
 people to rise 82

48 POINT FRENCH OLD STYLE NO 2

4A \$4 50 4A 7a \$6 50

FRANKLIN
When from
Debaters 76

60 POINT FRENCH OLD STYLE NO 2

4A \$7 50 4A 5a \$12 50

HEROES
Ending 98

72 POINT FRENCH OLD STYLE NO 2

3A \$8 40 3A 4a \$14 00

PUBLIC
Guard 8

FRENCH ELZEVIR No 1

8 POINT FRENCH ELZEVIR No 1

ITALIC 28 A 80 a \$3 00 40 A 20 A 90 a \$4 00

WHEN, in the course of human events, it becomes necessary for one people to dissolve the political bands which have connected them with another, and to assume, among the powers of the earth, the separate and equal station to which the laws of nature and of nature's God entitle them, a decent respect to the opinions of mankind requires that they should declare the causes which impel them to the separation. We hold these truths to be self-evident, that all men are created equal; that they are endowed by their Creator with certain unalienable rights; that among these, are life, liberty, and the pursuit of happiness. That, to secure these rights, governments are instituted among men, deriving their just powers from the consent of the governed; that, whenever any government becomes *destructive of these ends, it is the right* of the people to alter or to abolish it, and to institute a new government, laying its foundation on such principles, and organizing its powers in such form, as to them shall seem most likely to effect their safety and happiness. Prudence, indeed, will dictate that governments long established, should not be changed for light and transient causes; and, accordingly, all experience hath shown, that mankind are more disposed to suffer, while evils are sufferable, than to right themselves by abolishing the forms to which they are accustomed. But, when a long train of

Lower case a to z, 12½ ems

ABCDEFGHIJKLMNPOQRSTUVWXYZ

1234567890

10 POINT FRENCH ELZEVIR No 1

ITALIC 28 A 80 a \$3 80 40 A 20 A 80 a \$4 75

WHEN, in the course of human events, it becomes necessary for one people to dissolve the political bands which have connected them with another, and to assume, among the powers of the earth, the separate and equal station to which the laws of nature and of nature's God entitle them, a decent respect to the opinions of mankind requires that they should declare the causes which impel them to the separation. We hold these truths to be self-evident, that all men are created equal; that they are endowed by their Creator with certain unalienable rights; *that among these, are life, liberty,* and the pursuit of happiness. That, to secure these rights, governments are instituted among men, deriving their just powers from the consent of the governed; that, whenever any government becomes destructive of these ends, it is the right of the people to alter or to abolish it, and to institute a new government, laying its

Lower case a to z, 12 ems

ABCDEFGHIJKLMNPOQRSTUVWXYZ

1234567890

12 POINT FRENCH ELZEVIR No 1

ITALIC 20 A 50a \$3 94 28 A 16 A 62a \$5 00

WHEN, in the course of human events, it becomes necessary for one people to dissolve the political bands which have connected them with another, and to assume, among the powers of the earth, the separate and equal station to which the laws of nature and of nature's God entitle them, a decent respect to the opinions of mankind requires that they should declare the causes *which impel them to the separation*. We hold these truths to be self-evident, that all men are created equal; that they are endowed by their Creator with certain unalienable rights; that among these, are life, liberty, and the pursuit of happiness. That, to secure

Lower case a to z, 12½ ems

ABCDEFGHIJKLMNOPQRSTUVWXYZ
1234567890

14 POINT FRENCH ELZEVIR No 1

ITALIC 16 A 36a \$3 90 20 A 10 A 50a \$5 00

WHEN, in the course of human events, it becomes necessary for one people to dissolve the political bands which have connected them with another, and to assume, among the powers of the earth, the separate and equal station to which the laws of nature and of nature's God *entitle them, a decent respect* to the opinion of mankind requires that they should declare the causes which impel them to the separation. We hold these truths to be self-evident, that all men are created equal; that they are en-

ABCDEFGHIJKLMNOPQRSTUVWXYZ
1234567890

CUSHING SERIES

6 POINT

20A 12A 50a \$3 50

WHEN, in the course of human events, it becomes necessary for one people to dissolve the political bands which have connected them with another, and to assume, among the powers of the earth, the separate and equal station to which the laws of nature and of nature's God entitle them, a decent respect to the opinions of mankind requires that *they should declare the causes which impel them to the separation.* We hold these truths to be self-evident, that all men are created equal; that they are endowed by their Creator with certain unalienable rights; that among these, are life, liberty, and the pursuit of happiness. That, to secure these rights, governments are instituted among

Lower case a to z, 13 $\frac{3}{4}$ ems

ABCDEFGHIJKLMN OPQRSTUVWXYZ
1234567890

8 POINT

20A 12A 44a \$4 00

WHEN, in the course of human events, it becomes necessary for one people to dissolve the political bands which have connected them with another, and to assume, among the powers of the earth, the separate and equal station to which the laws of nature and of nature's God entitle them, a decent respect to the opinions of mankind requires that they should declare the causes which impel them to the separation. We hold these truths to

Lower case a to z, 12 $\frac{3}{4}$ ems

ABCDEFGHIJKLMN OPQRSTUVWXYZ
1234567890

10 POINT

16A 10A 40a \$4 50

WHEN, in the course of human events, it becomes necessary for one people to dissolve the political bands which have connected them with another, and to assume, among the powers of the earth, the separate and equal station to which the laws of nature and of nature's God entitle them, a decent respect to the opinions of mankind requires that *they should declare the causes which impel them to the separation.* We hold these truths to be self-evident, that all men are created equal; that they are endowed by their Creator with certain unalienable rights; that among these, are life, liberty, and the pursuit of happiness. That, to secure these rights, governments are instituted

Lower case a to z, 11 $\frac{1}{4}$ ems

ABCDEFGHIJKLMN OPQRSTUVWXYZ
1234567890

12 POINT

14A 8A 36a \$5 00

WHEN, in the course of human events, it becomes necessary for one people to dissolve the political bands which have connected them with another, and to assume, among the powers of the earth, the separate and equal station to which the laws of nature and of nature's God entitle them, a decent respect to the opinions of mankind requires that they should declare the causes

Lower case a to z, 12 ems

ABCDEFGHIJKLMN OPQRSTUVWXYZ
1234567890

CUSHING ITALIC

6 POINT

28 A 80a \$2 60

When, in the course of human events, it becomes necessary for one people to dissolve the political bands which have connected them with another, and to assume, among the powers of the earth, the separate and equal station to which the laws of nature and of nature's God entitle them, a decent respect to the opinions of mankind requires that they should declare the causes which impel them to the separation. We hold these truths to be self-evident, that all men are created equal; that they are endowed by their Creator with certain unalienable rights; that among these, are life, liberty, and the pursuit of happiness. That, to secure these rights, governments are instituted among men, deriving their just powers from

Lower case a to z, 13¼ ems

ABCDEFGHIJKLMNPOQRSTUVWXYZ
1234567890

8 POINT

28 A 80a \$3 00

When, in the course of human events, it becomes necessary for one people to dissolve the political bands which have connected them with another, and to assume, among the powers of the earth, the separate and equal station to which the laws of nature and of nature's God entitle them, a decent respect to the opinions of mankind requires that they declare the causes which impel them to the separation. We hold these truths to be self-evident, that all men are created equal; that they are

Lower case a to z, 11¼ ems

ABCDEFGHIJKLMNPOQRSTUVWXYZ
1234567890

10 POINT

28 A 80a \$3 80

When, in the course of human events, it becomes necessary for one people to dissolve the political bands which have connected them with another, and to assume, among the powers of the earth, the separate and equal station to which the laws of nature and of nature's God entitle them, a decent respect to the opinions of mankind requires that they should declare the causes which impel them to the separation. We hold these truths to be self-evident, that all men are created equal; that they are endowed by their Creator with certain unalienable rights; that among these, are life, liberty, and the pursuit of happiness. That, to secure these rights, governments are instituted among men, deriving their just

Lower case a to z, 10¼ ems

ABCDEFGHIJKLMNPOQRSTUVWXYZ
1234567890

12 POINT

20 A 50a \$3 94

When, in the course of human events, it becomes necessary for one people to dissolve the political bands which have connected them with another, and to assume, among the powers of the earth, the separate and equal station to which the laws of nature and of nature's God entitle them, a decent respect to the opinions of mankind requires that they should declare the causes which impel them to the

Lower case a to z, 11½ ems

ABCDEFGHIJKLMNPOQRSTUVWXYZ
1234567890

CUSHING MONOTONE

8 POINT CUSHING MONOTONE 15

WHEN, in the course of human events, it becomes necessary for one people to dissolve the political bands which have connected them with another, and to assume, among the powers of the earth, the separate and equal station to which the laws of nature and of nature's God entitle them, a decent respect to the opinions of mankind requires that they should declare the causes which impel them to the separation. We hold these truths to be self-evident, that all men are created equal; that they are endowed by their Creator with certain unalienable rights; that among these, are life, liberty, and the pursuit of happiness. That, to secure these rights, governments are instituted among men, deriving their just powers from the consent of the governed; that, whenever any form of government becomes destructive of these ends, it is the right of the people to alter or to abolish it, and to institute a new government, laying its foundation on such principles, and organizing its powers in such form, as to them shall seem most likely to effect their safety and happiness. Prudence, indeed, will dictate that governments long established, should not be changed for light and transient causes; and, accordingly, all experience hath shown, that mankind are more disposed to suffer, while evils are sufferable, than to right themselves by abolishing the forms to which they are accustomed. But, when a long train of abuses and usurpations, pursuing invariably the same object, evinces a design to reduce them under absolute despotism, it is their right, it is their duty, to throw off such government, and to provide new guards for their future security. Such has been the patient sufferance of these colonies, and such is now the necessity which con-

Lower case a to z, 12³/₄ ems

ABCDEFGHIJKLMN OPQRSTUVWXYZ

1234567890

10 POINT CUSHING MONOTONE 1

WHEN, in the course of human events, it becomes necessary for one people to dissolve the political bands which have connected them with another, and to assume, among the powers of the earth, the separate and equal station to which the laws of nature and of nature's God entitle them, a decent respect to the opinions of mankind requires that they should declare the causes which impel them to the separation. We hold these truths to be self-evident, that all men are created equal; that they are endowed by their Creator with certain unalienable rights; that among these, are life, liberty, and the pursuit of happiness. That, to secure these rights, governments were instituted among men, deriving their just powers from the consent of the governed; that, whenever any form of government becomes destructive of these ends, it is the right of the people to alter or to abolish it, and to institute a new government, laying its foundation on such principles, and organizing it powers in such form, as to them shall seem most likely to effect their safety and happiness. Prudence, indeed, will dictate that governments long

Lower case a to z, 12¹/₄ ems

ABCDEFGHIJKLMN OPQRSTUVWXYZ

1234567890

10 POINT CUSHING MONOTONE No 2 15

When, in the course of human events, it becomes necessary for one people to dissolve the political bands which have connected them with another, and to assume, among the powers of the earth, the separate and equal station to which the laws of nature and of nature's God entitle them, a decent respect to the opinions of mankind requires that they should declare the causes which impel them to the separation. We hold these truths to be self-evident, that all men are created equal; that they are endowed by their Creator with certain unalienable rights; that among these, are life, liberty, and the pursuit of happiness. That, to secure these rights, governments are instituted among men, deriving their just powers from the consent of the governed; that, whenever any form of government becomes destructive of these ends, it is the right of the people to alter or to abolish it, and to institute a new government, laying its foundation on such principles, and organizing

Lower case a to z, 13½ ems

ABCDEFGHIJKLMN OPQRSTUVWXYZ
1234567890

11 POINT CUSHING MONOTONE 15

When, in the course of human events, it becomes necessary for one people to dissolve the political bands which have connected them with another, and to assume, among the powers of the earth, the separate and equal station to which the laws of nature and of nature's God entitle them, a decent respect to the opinions of mankind requires that they should declare the causes which impel them to the separation. We hold these truths to be self-evident, that all men are created equal; that they are endowed by their Creator with certain unalienable rights; that among these, are life, liberty, and the pursuit of happiness. That, to secure these rights, governments are instituted among men, deriving their just powers from the consent of the governed; that, whenever any form of government becomes destructive of these ends, it is the right of the people to alter or to abolish it, and to institute a new government, laying its foundation on such principles, and organizing its powers in such form, as

Lower case a to z, 11½ ems

ABCDEFGHIJKLMN OPQRSTUVWXYZ
1234567890

SELF SPACING OLD STYLE ROMAN AND ITALIC

For description of Self Spacing Type see pages 52 and 53

6 POINT SELF SPACING OLD STYLE NO 27

Unit of measure, 11 to Pica

THE common widths of book pages, miscellaneous jobs and newspaper columns are some number of Pica ems, therefore the Pica em is taken as the basis for Self Spacing type. The thinnest space in all fonts is some exact fraction of a Pica, and this fraction of Pica is called the unit of measure. All characters, spaces and quads in the font are made some exact multiple of this unit in width, so that the sizes of all faces will work perfectly together in the regular labor-saving measures. This unit of measure may be one-sixth, one-seventh, one-eighth, one-ninth, etc., of a Pica em, as may be desired, to produce condensed, medium or extended faces. A detailed description is printed in this Specimen Book. *Self Spacing type sets line for line with the ordinary Roman, where the lengths of the alphabets*

Lower case a to z, 17 ems

ABCDEFGHIJKLMNPOQRSTUVWXYZ
1234567890

8 POINT SELF SPACING OLD STYLE NO 22

Unit of measure, 10 to Pica

THE common widths of book pages, miscellaneous jobs and newspaper columns are some number of Pica ems, therefore the Pica em is taken as the basis for Self Spacing type. The thinnest space in all fonts is some exact fraction of a Pica, and this fraction of Pica is called the unit of measure. All characters, spaces and quads in the font are made some exact multiple of this unit in width, so that the sizes of all faces will work perfectly together in the regular labor-saving measures. This unit of measure may be one-sixth, one

Lower case a to z, 14½ ems

ABCDEFGHIJKLMNPOQRSTUVWXYZ
1234567890

9 POINT SELF SPACING OLD STYLE NO 28

Unit of measure, 9 to Pica

THE common widths of book pages, miscellaneous jobs and newspaper columns are some number of Pica ems, therefore the Pica em is taken as the basis for Self Spacing type. The thinnest space in all fonts is some exact fraction of a Pica, and this fraction of Pica is called the unit of measure. All characters, spaces and quads in the font are made some exact multiple of this unit in width, so that the sizes of all faces

Lower case a to z, 13½ ems

ABCDEFGHIJKLMNPOQRSTUVWXYZ
1234567890

10 POINT SELF SPACING OLD STYLE NO 29

Unit of measure, 9 to Pica

THE common widths of book pages, miscellaneous jobs and newspaper columns are some number of Pica ems, therefore the Pica em is taken as the basis for Self Spacing type. The thinnest space in all fonts is some exact fraction of a Pica, and this fraction of Pica is called the unit of measure. All characters, spaces and quads in the font are made some exact multiple of this unit in width, so that the sizes of all faces

Lower case a to z, 12½ ems

ABCDEFGHIJKLMNPOQRSTUVWXYZ
1234567890

10 POINT SELF SPACING OLD STYLE NO 24

Unit of measure, 8 to Pica

THE common widths of book pages, miscellaneous jobs and newspaper columns are some number of Pica ems, therefore the Pica em is taken as the basis for Self Spacing type. The thinnest space in all fonts is some exact fraction of a Pica, and this fraction of Pica is called the unit of measure. All characters, spaces and quads in the font are made some exact multiple of this unit in width, so that the sizes of all faces will work *perfectly together in the regular labor-saving measures. This unit of measure may be one-sixth, or one-*

Lower case a to z, 14 ems

ABCDEFGHIJKLMN OPQRSTUVWXYZ
1234567890

11 POINT SELF SPACING OLD STYLE NO 25

Unit of measure, 8 to Pica

THE common widths of book pages, miscellaneous jobs and newspaper columns are some number of Pica ems, therefore the Pica em is taken as the basis for Self Spacing type. The thinnest space in all fonts is some exact fraction of a Pica, and this fraction of Pica is called the unit of measure. All characters, spaces and quads in the font are made some exact multiple of this unit in width, so that the sizes of all faces will work *perfectly together in the regular labor-saving measure*

Lower case a to z, 12²/₅ ems

ABCDEFGHIJKLMN OPQRSTUVWXYZ
1234567890

12 POINT SELF SPACING OLD STYLE NO 26

Unit of measure, 7 to Pica

THE common widths of book pages, miscellaneous jobs and newspaper columns are some number of Pica ems, therefore the Pica em is taken as the basis for Self Spacing type. The thinnest space in all fonts is some exact fraction of a Pica, and this fraction of Pica is called the *unit of measure. All characters, spaces and quads in the font are made some exact multiple*

Lower case a to z, 13¹/₄ ems

ABCDEFGHIJKLMN OPQRSTUVWXYZ
1234567890

SELF SPACING OLD STYLE ITALIC

6 POINT SELF SPACING OLD STYLE ITALIC NO 27

CIRCULAR FONT \$7 00

The common widths of book pages, miscellaneous jobs and newspaper columns are some number of Pica ems, therefore the Pica em is taken as the basis for Self Spacing type. The thinnest space in all fonts is some exact fraction of a Pica, and this fraction of Pica is called the unit of measure. All characters, spaces and quads in the font are made some exact multiple of this unit in width, so that the sizes of all faces will work perfectly together in the regular labor-saving measures. This unit of measure may be one-sixth, one-seventh, one-eighth, one-ninth, etc., of a Pica em, as may be desired, to

8 POINT SELF SPACING OLD STYLE ITALIC NO 22

CIRCULAR FONT \$5 40

The common widths of book pages, miscellaneous jobs and newspaper columns are some number of Pica ems, therefore the Pica em is taken as the basis for Self Spacing type. The thinnest space in all fonts is some exact fraction of a Pica, and this fraction of Pica is called the unit of measure. All characters, spaces and quads in the font are made some exact multiple of this unit in width, so that the sizes of all

9 POINT SELF SPACING OLD STYLE ITALIC NO 28

CIRCULAR FONT \$4 80

The common widths of book pages, miscellaneous jobs and newspaper columns are some number of Pica ems, therefore the Pica em is taken as the basis for Self Spacing type. The thinnest space in all fonts is some exact fraction of a Pica, and this fraction of Pica is called the unit of measure. All characters, spaces and quads in the font are made some exact multiple of

10 POINT SELF SPACING OLD STYLE ITALIC NO 24

CIRCULAR FONT \$4 45

The common widths of book pages, miscellaneous jobs and newspaper columns are some number of Pica ems, therefore the Pica em is taken as the basis for Self Spacing type. The thinnest space in all fonts is some exact fraction of a Pica, and this fraction of Pica is called the

11 POINT SELF SPACING OLD STYLE ITALIC NO 25

CIRCULAR FONT \$4 20

The common widths of book pages, miscellaneous jobs and newspaper columns are some number of Pica ems, therefore the Pica em is taken as the basis for Self Spacing type. The thinnest space in all fonts is some exact fraction of a Pica, and this fraction of Pica is called the

12 POINT SELF SPACING OLD STYLE ITALIC NO 26

CIRCULAR FONT \$3 95

The common widths of book pages, miscellaneous jobs and newspaper columns are some number of Pica ems, therefore the Pica em is taken as the basis for Self Spacing type. The thinnest space in all fonts is some exact fraction of a

Spaces and Quads are included with each font

SELF SPACING OLD STYLE BOLD

Designed specially to work with Self Spacing Old Style Romans shown on pages 146 and 147

8 POINT

30 A 50 a \$3 30

THIS SERIES of Old Style Bold was cut after many inquiries for a Job Face that could be used with Self Spacing to emphasize certain words. All sizes shown on this page will line and justify with the corresponding sizes of our Old Style Self Spacing Series. Repeated ex-

periments have shown that the average compositor gains about 25 per cent. with no trouble in justification whatever. In the matter of correction of proofs the saving is something

9 POINT

28 A 45 a \$3 35

THIS SERIES of Old Style Bold was cut after many inquiries for a Job Face that could be used with Self Spacing to emphasize certain words. All sizes shown above will line and justify with the corresponding sizes of our Old Style Self Spacing

Series. Repeated experiments with Self Spacing Type have shown that the average compositor gains about 25 per cent. in speed with no trouble in justification whatever.

10 POINT

25 A 40 a \$3 50

THIS SERIES of Old Style Bold was cut after many inquiries for a Job Face that could be used with Self Spacing to emphasize certain words. All sizes shown on this page will line and justify with the corresponding sizes

of all our Old Style Self Spacing Series. Repeated experiments with Self Spacing Type have shown

12 POINT

25 A 38 a \$4 00

THIS SERIES of Old Style Bold was cut after many inquiries for a Job Face that could be used with Self Spacing to emphasize certain words. All sizes shown on this page will line and justify with the corresponding sizes of our Old Style Self Spacing Series. Repeated experiments with

CAXTON OLD STYLE ROMAN AND ITALIC

12

6 POINT CAXTON OLD STYLE ROMAN

32 A 24 A 100 a \$4 45

WHEN, in the course of human events, it becomes necessary for one people to dissolve the political bands which have connected them with another, and to assume, among the powers of the earth, the separate and equal station to which the laws of nature and of nature's God entitle them, a decent respect to the opinions of mankind requires that they should declare the causes which impel them to the separation. We hold these truths to be self-evident, that all men are created equal; that they are endowed by their Creator with certain unalienable rights; that among these, are life, liberty, and the pursuit of happiness. That, to secure these rights, governments are instituted among men, deriving their just powers from the consent of the governed; that, whenever any government becomes destructive of these ends, it is the right of the people to alter or to abolish it, and to institute a new government, laying its foundation on such *principles and organizing its powers* in such form as to them shall seem most likely to effect their safety and happiness. Prudence, indeed, will dictate that governments long established, should not be changed for light and transient causes; and, accordingly, all experience hath shown, that mankind are more disposed to suffer while

ABCDEFGHIJKLMNPOQRSTUVWXYZ

1234567890

6 POINT CAXTON OLD STYLE ITALIC

32 A 200 a \$6 70

WHEN, IN THE COURSE OF HUMAN EVENTS, IT BECOMES necessary for one people to dissolve the political bands which have connected them with another, and to assume, among the powers of the earth, the separate and equal station to which the laws of 123

8 POINT CAXTON OLD STYLE ROMAN

24 A 18 A 64 a \$3 70

WHEN, in the course of human events, it becomes necessary for one people to dissolve the political bands which have connected them with another, and to assume, among the powers of the earth, the separate and equal station to which the laws of nature and of nature's God entitle them, a decent respect to the opinions of mankind requires that they should declare the causes which impel them to the separation. We hold these truths to be self-evident, that all men are created equal; that they are endowed by their Creator with certain unalienable rights; that among these, are life, liberty, and the pursuit of happiness. That, to secure these *rights, governments are instituted* among men, deriving their just powers from the consent of the governed; that, whenever any

ABCDEFGHIJKLMNPOQRSTUVWXYZ

1234567890

8 POINT CAXTON OLD STYLE ITALIC

32 A 200 a \$8 15

WHEN, IN THE COURSE OF HUMAN EVENTS, IT BECOMES necessary for one people to dissolve the political bands which have connected them with another, to 123

10 POINT GAXTON OLD STYLE ROMAN

18 A 12 A 50 a \$3 50

WHEN, in the course of human events, it becomes necessary for one people to dissolve the political bands which have connected them with another, and to assume, among the powers of the earth, the separate and equal station to which the laws of nature and of nature's God entitle them, a decent respect to the opinions of *mankind requires that they* should declare the causes which impel them to the separation. We hold these truths to be self-evident, that all men are created equal; that they are endowed by their Creator with certain unalienable rights; that among

ABCDEFGHIJKLMN**OP**QRSTUVWXYZ
1234567890

10 POINT GAXTON OLD STYLE ITALIC

24 A 140 a \$6 65

WHEN, IN THE COURSE OF HUMAN EVENTS, it becomes necessary for one people to dissolve the political bands which have connected them with another, and to assume, among the powers of 285

12 POINT GAXTON OLD STYLE ROMAN

18 A 12 A 50 a \$4 75

WHEN, in the course of human events, it becomes necessary for one people to dissolve the political bands which have connected them with another, and to assume, among the powers of the *earth, the separate and equal* station to which the laws of nature and of nature's God entitle them, a decent respect to the opinions of mankind requires that they should predicate the causes which impel them to the

ABCDEFGHIJKLMN**OP**QRSTUVWXYZ
1234567890

12 POINT GAXTON OLD STYLE ITALIC

18 A 100 a \$5 70

WHEN, IN THE COURSE OF HUMAN events, it becomes necessary for one people to dissolve the political bands which 123

18 POINT CAXTON OLD STYLE

10 A 20 a \$3 65

REVOLUTIONARY FATHERS
When, in the course of human
events, it becomes necessary for
one people to dissolve the 6412

24 POINT CAXTON OLD STYLE

8 A 16 a \$4 90

SOLID GOVERNMENT
When, in the course of
human events, it becomes
necessary that one 1892

30 POINT CAXTON OLD STYLE

6 A 12 a \$5 15

HEROIC PATRIOTS
When, in the course
of human events, 30

36 POINT CAXTON OLD STYLE

5 A 10 a \$8 70

GOVERNMENT
When, in the '72

48 POINT CAXTON OLD STYLE

4A 8a \$9 10

DECLARED
that a system
of learning 28

60 POINT CAXTON OLD STYLE

3A 8a \$10 50

HUMANE
may honor

72 POINT CAXTON OLD STYLE

3A 5a \$15 50

HEROIC
and most

OLD STYLE No 83—Card Series

30 POINT

4A \$1 00 6A 12a \$5 60

HEROIC FATHERS
When, in the course of 98

24 POINT

6A \$0 95 8A 16a \$4 75

NOBLE AND STRONG
When, in the course of 321

22 POINT

6A \$0 75 8A 16a \$3 50

EMPHATIC OF DEVOTION
When, in the course of an 865

18 POINT

8A \$0 55 10A 20a \$2 95

AMERICA'S PROUD ASPIRATION
When, in the course of human events, it be-
comes necessary for one people to 4567 1/2

12 POINT

25A 50a \$4 00

BRIGHT REPUBLIC
When, in the course of
human events, it becomes

10 POINT

25A 75a \$3 80

GENUINE CONSTITUTION
When, in the course of human
events, it becomes necessary for
one people to dissolve the poli-

8 POINT

30A 150a \$4 75

HONORABLE INDEPENDENCE
When, in the course of human events,
it becomes necessary for one people
to dissolve the political bands which
have connected them with another,

1234567890

6 POINT

30A 150a \$4 00

DECLARATION FROM GOVERNMENT
When, in the course of human events, it be-
comes necessary for one people to dissolve
the political bands which have connected
them with another, and to assume, among the
powers of the earth, the separate and equal

1234567890

For other sizes see page 117

OLD STYLE ITALIC No 83

42 POINT

3 A 6a \$6 00

TRIED Patriots

30 POINT

5 A 10a \$6 00

Notifications MADE

24 POINT

8 A 16a \$4 25

*GOOD GOVERNMENTS
When, in the course of human*

22 POINT

8 A 16a \$3 80

*HISTORIC CHARACTERS
When, in the course of human 58*

18 POINT

10 A 20a \$3 10

*ADMIRER AMERICAN THRIFT
When, in the course of human events, it
becomes necessary for one people to 23456*

12 POINT

20 A 40a \$3 05

*INDEPENDENCE
When, in the course of
human events, it becomes*

10 POINT

20 A 40a \$2 40

*HEROIC GOVERNMENTS
When, in the course of human
events, it becomes necessary for one*

8 POINT

25 A 75a \$2 95

*REVOLUTIONARY FATHERS
When, in the course of human events,
it becomes necessary for one people to
1234567890*

6 POINT

25 A 75a \$2 40

*DECLARATION OF INDEPENDENCE
When, in the course of human events, it be
comes necessary for one people to dissolve the
1234567890*

OLD STYLE No 43

40 POINT

5 A \$4 60

SUPERFINE

36 POINT

5 A \$3 80

UPHOLDING

28 POINT

8 A \$3 60

FIENDS

24 POINT

10 A \$3 45

BARREN

22 POINT

12 A \$3 05

PEOPLED

20 POINT

12 A \$2 85

HYMNALS

16 POINT

14 A \$2 50

MACHINIST

12 POINT

18 A \$1 95

PROTECTIONIST

OLD STYLE TWO-LINE

24 POINT

12 A \$3 00

MODERN CRUISERS

20 POINT

14 A \$2 50

GRAND OCEAN RACER

16 POINT

16 A \$2 00

BOMBARDED

1 2 3 4 5 6 7

12 POINT

18 A \$1 50

ANCIENT FORTS

1 2 3 4 5 6 7 8 9 0

OLD STYLE CONDENSED No 40

36 POINT 7 A \$3 60
MISERS

28 POINT 10 A \$3 85
CHINESE

24 POINT 12 A \$3 50
HURTFUL

22 POINT 16 A \$3 70
MANIFOLD

20 POINT 18 A \$3 70
SPITZ DOGS

18 POINT 22 A \$3 30
YOUNG TREES

16 POINT 22 A \$3 10
TRUE WOMEN

14 POINT 22 A \$2 75
SUMMER GOSSIP

12 POINT 30 A \$2 50
SACRED MEMOIRS

10 POINT 36 A \$2 35
HARVESTING JUBILEE

EDINBURGH TITLE

36 POINT 7 A \$4 65
RAILROADER

24 POINT 10 A \$3 00
MUSICAL CORNET

20 POINT 12 A \$2 50 16 POINT 18 A \$2 00
MOTHERS ROAD HOUSE

14 POINT 18 A \$2 00 12 POINT 16 A \$1 50
ASKED PROMPT FIGURING LOSSES

10 POINT 20 A \$1 50 9 POINT 22 A \$1 50
PRACTICE FOR RACES REPAIRED OR ADJUSTED

1 2 3 4 5 6 7 8 9 0

1 2 3 4 5 6 7 8 9 0

OLD STYLE CONDENSED No 120

42 POINT

4 A \$2 75

FINE MORNING

36 POINT

5 A \$2 85

SELECT 5 STORE

32 POINT

6 A \$2 55

MANILA GENERALS

30 POINT

8 A \$2 40

GOOD MEN

24 POINT

8 A \$1 95

FINE PEAR

22 POINT

10 A \$1 90

CEDAR LAKE

20 POINT

12 A \$2 00

ARBITRATION

18 POINT

16 A \$2 00

ELECTRIC PLANT

16 POINT

16 A \$1 55

HEROIC REPUBLIC

12 POINT

18 A \$1 35

LIGHTNING EXPRESS

10 POINT

24 A \$1 30

HARMONIOUS GRUMBLING

9 POINT

24 A \$1 15

POCKET MATCH SAFES
WORKMANSHIP GUARANTEED
1234567890

8 POINT

32 A \$1 25

HONORABLE DIPLOMATS
DISTRIBUTE GREATER EMOLUMENTS
1234567890

FRENCH OLD STYLE No 1

72 POINT

3 A \$8 40

BURNER

60 POINT

4 A \$7 60

RANCHES

48 POINT

4 A \$4 50

MEASURING

36 POINT

5 A \$3 00

HINGES

30 POINT

7 A \$2 90

BURNISH

24 POINT

10 A \$2 80

RESOURCE

20 POINT

14 A \$2 70

CONVERSION

16 POINT

18 A \$2 50

GERMAN SAILORS

14 POINT

20 A \$2 30

HUMANE PRINCIPLE

12 POINT

20 A \$1 55

COLONIAL RESIDENCES

10 POINT

24 A \$1 60

LIBERAL VIEWS EXPRESSED

8 POINT

30 A \$1 65

DESIRE AMERICAN PRODUCTS

6 POINT

30 A \$1 25

PEACEABLE NEGOTIATIONS CONCLUDED

1 2 3 4 5 6 7 8 9 0

1 2 3 4 5 6 7 8 9 0

OLD STYLE CONDENSED No 122

72 POINT

3 A \$4 65 3 A 6 a \$9 50

NOT TO Land

60 POINT

3 A \$3 50 3 A 6 a \$7 95

Boys AND MEN

48 POINT

3 A \$2 45 3 A 6 a \$5 75

DOG AT Home 82

44 POINT

3 A \$2 00 3 A 6 a \$4 80

HIGH ART LOVER
Crossing 94 Swords

42 POINT

3 A \$1 75 3 A 6 a \$3 85

PEACH OR ORANGE
Expensive 26 Blossoms

OLD STYLE CONDENSED No 122

36 POINT

4A \$1 45 7A 8a \$3 70

FIGHTING FOR Freedom

* 30 POINT

5A \$1 25 7A 11a \$4 50

THEIR STANDARD Unfurled

24 POINT

6A \$1 00 6A 12a \$2 65

SUMMER NIGHTS Entertainments

20 POINT

8A \$1 00 8A 16a \$2 55

Electric Burglar ALARM INSTRUMENTS

18 POINT

10A \$0 90 10A 20a \$2 50

UNIVERSITY GIRLS ON THE FORM GROTESQUE
Mountain Freedom is Declared 465

12 POINT

16A \$0 80 16A 32a \$2 00

GENTLE GERMAN MAIDENS
Attractive and Inviting

10 POINT

20A \$0 75 20A 40a \$2 05

PATRIOTS RESCUED IRISHMEN
Strict Attention in the Ranks

9 POINT

24A 48a \$2 15

AMERICA'S COURAGEOUS ABILITIES
Tested During the Spanish War
1234567890

8 POINT

32A 64a \$2 65

ENGLISH MINERALOGICAL RESEARCHES
Examinations for School Children
1234567890

RONALDSON CONDENSED

48 POINT

5 A 8 a \$5 90

SOBER Minded GIRL

36 POINT

7 A 12 a \$5 25

Northern PATROL Stations

30 POINT

8 A 14 a \$4 15

IMPORTANT PERSON
Mediocrity's Dictatorial Behavior

24 POINT

10 A 18 a \$3 60

PROTESTS
Crossing Bayonets

18 POINT

14 A 28 a \$3 15

RESTORATION
Luxuries of Relaxation

12 POINT

22 A 45 a \$2 70

YOUTHFUL ADMIRER
Treading on Enchanted Ground
Dream of Fairyland

10 POINT

26 A 52 a \$2 55

INTIMIDATE & BUGBEAR
Ghost Story and Scarecrow Retailers
Improved Burglar Alarm

8 POINT

30 A 60 a \$2 50

SCIENTIFIC INCONGRUITY
Cherished Hopes are Frequently Shattered
Centuries of Sanguine Expectation
1 2 3 4 5 6 7 8 9 0

6 POINT

36 A 70 a \$2 50

EXCELLENCE IN WORKMANSHIP
Trustworthy Dealing with the World and his Wife
Untainted by Equivocation
1 2 3 4 5 6 7 8 9 0

OLD STYLE CONDENSED No 4

48 POINT

6 A 10 a \$5 00

SECTION CYLINDER
Practical Automatic Registers

40 POINT

6 A 10 a \$4 00

REAL FRIEND BANNER
Gratitude Rewards Human Hearts

36 POINT

10 A 15 a \$4 50

USEFUL PRECIOUS METAL
Having Intrinsic and Exchange Values

24 POINT

15 A 20 a \$3 60

KIMBERLEY DIAMOND EXCHANGE
South African Exploring and Mining Companies

18 POINT

20 A 30 a \$3 30

CHRISTMAS PRESENT
Santa Claus Likes Little Ones
1234567890

12 POINT

25 A 40 a \$2 40

EVERY HUMAN HEART FINDS
Consolation and Inspiration in Music
1234567890

Two styles of figures furnished with all sizes

RONALDSON EXTENDED

48 POINT

4A 6a \$8 45

FOUR Girls

36 POINT

5A 8a \$6 55

Round NESTS

30 POINT

6A 10a \$5 40

STATED
National Revenue

24 POINT

8A 12a \$4 65

WAVE
Departing

18 POINT

10A 16a \$4 00

PARENT
Loving Child

12 POINT

18A 28a \$3 50

MEMORIALS
Literary Societies
Fashionable

10 POINT

20A 30a \$3 00

INDUSTRIOUS
Determinate Scholar
Pushed Ahead

8 POINT

22A 32a \$2 70

MELODRAMA
Composer and Performer
Loudly Applauded
1234567890

6 POINT

25A 40a \$2 45

MORNING SQUEALER
Latest Sensational Newspaper
Calumnious Articles
1234567890

OLD STYLE EXTENDED

48 POINT

4 A \$4 75 4 A 6 a \$13 00

ONE Line

36 POINT

4 A \$2 50 4 A 6 a \$6 00

Leader RUSH

24 POINT

6 A \$2 00 6 A 10 a \$5 00

TROUBLES
Customary Tribute

18 POINT

9 A \$2 00 9 A 12 a \$3 50

CHURCH NEWS
Transubstantiation. Ethics

12 POINT

14 A \$1 50 14 A 22 a \$3 50

MINUTES
Dramatic School
Elocutionists

10 POINT

16 A \$1 25 16 A 22 a \$3 00

AMBITIOUS
Scholars' Recitation
Applauded

8 POINT

16 A \$1 00 20 A 30 a \$3 00

MUNCHAUSEN
Writer of Circus Poster
Facts For Fiction
1234567890

6 POINT

24 A 30 a \$2 75

SUMMER VERDURE
Smiling Rainbowed Meadow
Drooping Blossoms
1234567890

PARTHENIAN SERIES

72 POINT

3 A 6 a \$17 25

SIREN
Blonde

60 POINT

3 A 6 a \$12 10

GRANT
Evening

48 POINT

3 A 6 a \$9 60

ENDURE
Columbus

PARTHENIAN SERIES

36 POINT

4 A 8 a \$6 50

FREE CUBA
For Key West

24 POINT

6 A 12 \$4 65

MODERN CHARM
Latest Photographs
United States Bank

18 POINT

8 A 16 a \$4 15

GENERAL WHEELER
Unconcerned Ambitions
Observe a Golden Rule

12 POINT

12 A 24 a \$3 00

EVENING TEA
Public Buildings
United Kingdom

10 POINT

16 A 32 a \$2 60

BEAUTIFUL SHORE
From Summer Resort
New Wedding Dresses

9 POINT

16 A 32 a \$2 55

BUSINESS CHANCE
Good Business Gowns
Bank Accounts Small
1234567890

6 POINT

24 A 48 a \$2 75

IMPROVING RESTAURANT
AMERICAN EXPRESS
United States Bank Building
Leads to Eternal Happiness
1234567890

OLD STYLE BOLD

48 POINT

4 A 6 a \$15 00

HE Dug

36 POINT

4 A 6 a \$9 50

**GETS
Sure Tips**

24 POINT

5 A 7 a \$6 00

**COLUMBIA
Good Country**

18 POINT

7 A 10 a \$4 50

**PIRATICAL
Mysterious Person**

12 POINT

14 A 18 a \$4 00

**MASTIFF
Dog Howled**

10 POINT

15 A 20 a \$3 50

**DRUNKARD
Foolish Dispute**

8 POINT

18 A 24 a \$3 50

**CALAMITY
Howlers Muzzled
1284567**

6 POINT

16 A 22 a \$3 00

**CONGRATULATE
The Vigilant Officer
12845678**

FRENCH OLD STYLE EXTENDED

72 POINT

3 A 5 a \$12 50

Said NO

60 POINT

4 A 5 a \$11 75

HID Band

48 POINT

4 A 5 a \$7 50

Mark RING

36 POINT

4 A 8 a \$5 25

BONE Breakers

30 POINT

5 A 10 a \$4 75

Heroine NUMBER

24 POINT

6 A 12 a \$4 00

HERO
Denounced

18 POINT

8 A 16 a \$3 00

RECORD
Easily Broken

12 POINT

15 A 30 a \$2 75

358 MINERS
Seriously Consider

10 POINT

18 A 36 a \$2 75

NUMBER 246
Desires Wardens Pardon

CAXTON BOLD

72 POINT

3 A 5 a \$15 00

ROMAN
Chariots

60 POINT

3 A 6 a \$11 75

MURDER
Resources

48 POINT

4 A 8 a \$9 50

SWEARING
Phonographs

CAXTON BOLD

36 POINT

5 A 10 a \$6 50

CORN BROKER
Member Chicago

30 POINT

6 A 12 a \$5 60

HOUSEHOLD GEMS
Domestic Silverware

24 POINT

8 A 16 a \$4 90

EUROPEAN PICTURES
Electric Design Beautiful

18 POINT

10 A 20 a \$3 85

NEBRASKA EXCURSIONISTS
Building Operations Completed

12 POINT

18 A 36 a \$3 40

BASEBALL UMPIRE
Theatrical Celebrities
Forbids Encroachment

10 POINT

20 A 40 a \$3 00

COUNTLESS BREAKERS
Provocation and Sensation
Through Countless Paths

8 POINT

24 A 48 a \$3 20

NATIONAL CONVENTIONS
Timely Arbitration Necessary
Chrysanthemum Exhibitions
1234567890

6 POINT

24 A 48 a \$2 60

CYLINDER PRINTING PRESSES
Splendid Assortment Woodenware
International Tariff Complications
Made the Fastest Time on Record
1234567890

CUSHING OLD STYLE

48 POINT

4 A 6 a \$7 00

**BASE SINGER
Musical Talent**

36 POINT

5 A 6 a \$5 50

**WINTER OPENING
Grand Blanket Sales**

24 POINT

8 A 12 a \$4 50

**FLOURISHING INDUSTRY
Symptoms Indicate Strongly
that Prosperity is Returning**

18 POINT

12 A 16 a \$3 50

**THRIVING MERCANTILE HOUSES
Occupation of Porto Rico Stimulated
Rivalry among the Leading Exporters**

14 POINT

16 A 24 a \$3 25

**DEMANDS FOR SEASONABLE CLOTHING
The Prevailing Cold Weather has given a New
Impetus to the Manufacture of Heavy Textiles**

CUSHING OLD STYLE

12 POINT

20 A 30 a \$3 00

INDISPENSABLE FOR OUR PERMANENT GROWTH

To the Efficacy of the Union a Government for the Whole is Essential. No Alliances, however strict, between the Parts can be substituted, as they must lead to Infractions or Interruptions which all the Alliances have Experienced

11 POINT

22 A 34 a \$2 90

BIRDS GUIDED COLUMBUS IN HIS GLORIOUS DISCOVERY

Indications of Approaching Land became more certain, and excited Hopes in Proportion. Birds began to Appear in Flocks, flying in a Southwesterly Direction, and this induced Columbus to alter his Course toward the Quarter whither the Birds pointed their Flight

10 POINT

24 A 36 a \$2 75

THE MOST ADMIRABLE DISPOSITION OF BENJAMIN FRANKLIN

His Characteristic Passion seems to have been the Love of Everything Useful. This was to him the Sublime and Beautiful, which he was in quest of Every Week for Fifty Years. No Department was too humble for him to occupy himself in for the Purpose of Looking for the Useful

9 POINT

28 A 42 a \$2 75

TRUE PRINCIPLE OF LIBERTY

The Constitution is Obligatory upon all People. The Idea of the Power and the Right of the People to chose their own Government presupposes a Duty of Everybody to obey the Laws

8 POINT

28 A 42 a \$2 50

JERUSALEM RUINED BY ZEALOTS

If the Jews had yielded to the Liberal Spirit of Saint Paul, Jerusalem might have escaped its Awful Fate, and have survived with all its Splendor through the Centuries as the Head of the Church

7 POINT

26 A 40 a \$2 50

THE BEAUTIFUL YOSEMITE VALLEY

About the Time of the Full Moon, and in May or June, according to the Forwardness of the Season, is the Time to enjoy in their Perfection the Glories of the Waterfalls, as the Snow has not yet gone from the Hills

1234567890

6 POINT NO 1

24 A 36 a \$2 25

CONQUESTS OF THE KNIGHTS TEMPLARS

The Knights, under the Grandmaster Foulkes de Villaret, in Conjunction with some Italian Crusaders captured Rhodes and seven adjacent Islands from the Greek Pirates and carried on from there a Fierce War against the Saracens

1234567890

OLD STYLE ANTIQUE

48 POINT No 40

4 A 6 a \$8 00

BROADSIDE
Stone Arches

36 POINT No 40

6 A 9 a \$7 10

THE WAYSIDE
Hunting Grounds

30 POINT No 40

8 A 12 a \$6 00

LOUIS FAVAWALE
Designer of Fashions

24 POINT No 120

8 A 16 a \$5 80

DESIRED FLOWER
Beautiful Rose Gardens

20 POINT No 120

10 A 20 a \$4 60

HANDSOME ROMANCER
Southern Californian Legends

OLD STYLE ANTIQUE

18 POINT NO 120

12 A 24 a \$4 30

ROMAN WAS FIRST USED IN
the Netherlands about 1472. Being introduced into the Netherlands by Johannes de Westfalia, who, it is said, brought it from Italy in 1234

12 POINT NO 120

16 A 32 a \$2 85

ROMAN WAS FIRST USED IN THE NETH-
erlands about 1472. It was introduced into the Netherlands by Johannes de Westfalia, who, it is said, brought it from Italy in the year 1472. He located at Louvain, and after a number of works in semi-Gothic, published in 1483 an edition of Aeneas Silvius in the Italian letter. His font is elegant 890

10 POINT NO 120

18 A 36 a \$2 35

ROMAN WAS FIRST USED IN THE NETHERLANDS
about 1472. It was introduced into the Netherlands by Johannes de Westfalia, who, it is said, brought it from Italy in the year 1472. Then located at Louvain, and, after a number of works in semi-Gothic, published in 1483 an edition of Aeneas Silvius in the Italian letter. His font is elegant, and rather a lighter face than most of the Roman fonts of other countries. This printer seems to have been the only one in the Low Countries who used this type during the fifteenth century; nor 123456

8 POINT NO 120

20 A 40 a \$2 10

ROMAN WAS FIRST USED IN
the Netherlands in 1472. It was introduced into the Netherlands by Johannes de Westfalia, who, it is said, brought it from Italy in the year 1472. He located at Louvain, and, after a number of works in semi-Gothic, published in 1483 an edition of Aeneas Silvius in the Italian letter. His font is elegant, and rather a lighter 123456

6 POINT NO 120

24 A 48 a \$2 00

ROMAN WAS FIRST USED IN THE
Netherlands in 1472. It was introduced into the Netherlands by Johannes de Westfalia, who, some say, brought it from Italy in the year 1472. He located at Louvain, and after a number of works in semi-Gothic, published in 1473 an edition of Aeneas Silvius in the Italian letter. His font is elegant, and rather a lighter face than most of the early Roman fonts of other countries. This printer appears to have been the only one in the Low Countries who used this type during the fifteenth cen- 12345

OLD STYLE TITLE

36 POINT

4 A 7 a \$6 85

DYNAMO
Great Progress

30 POINT

6 A 9 a \$6 25

ELECTRIC
Lighting Triumph

24 POINT

8 A 12 a \$5 50

ASTRONOMER
Heavenly Observation

18 POINT

12 A 22 a \$5 25

MODERN WONDER
Musical Selections Repeated
Automatically

14 POINT

18 A 30 a \$5 00

STRIKING LIKENESS
Instantaneous Photograph Produced
Sunshine Necessary

— 4 —

OLD STYLE TITLE

12 POINT

22 A 32 a 84 95

ANTE-ADAMIC RESEARCH
Sciolistic Theory of Human Organisms
Dominance of Monkeyism

10 POINT

25 A 42 a 84 35

SELF-ACTING TELEPHONES
Instructive to the Egotistical and Self-conceited
Hearing Sharpened and Made Acute
Electrical Chatterbox

9 POINT

25 A 42 a 83 90

OBSERVATIONS AFTER SUNDOWN
Youth's Glittering Flittings or Old Men's Experience
Courtships and Merry-Making
Selecting Partners

8 POINT

25 A 42 a 83 90

THE TRAILING-SKIRT NUISANCE
Warranted Eventually to Kill every Devotee of Fashion
Cheap and Inexpensive Sweepers for Cities
Unsightly but Useful

7 POINT

25 A 42 a 83 85

UNIVERSAL MODERN MARTYRS
Wasp-Waisted Feminines and Fashion's Dally Followers
Exquisite Dandies and Shoe-Pinched Damsels
High-heeled Promenaders

6 POINT

30 A 52 a 83 75

NOTES ON THE LABOR QUESTION
Competency Speedily Acquired by Distributing Public Property
Views of the Confirmed Loafers Do-Nothing Society
Toll Reduced to a Minimum
1234567890

RONALDSON TITLE SLOPE

36 POINT

5 A 8 a \$6 00

CHILD *Spankers*

30 POINT

8 A 10 a \$5 25

GRUMBLING
Jawtickler Curatives

24 POINT

8 A 14 a \$4 50

TEXAN STEERS
Cowboy Lassos Electrified

18 POINT

12 A 22 a \$4 15

POCKET BATTERY
Thoroughly Paralyzes Pickpockets

12 POINT

20 A 40 a \$3 55

ELECTRIC
Burglar Alarm Hinges
For Chicken Coops

10 POINT

22 A 45 a \$3 35

RAPID TRANSIT
Fleeting Landscape Scene
Passing Glimpse

8 POINT

25 A 50 a \$3 15

CRIME PUNISHED
Appliances to Produce Torture
Suitable to the Offense
1 2 3 4 5 6 7 8 9 0

6 POINT

30 A 60 a \$3 00

DYNAMO & COMPANY
Contrivers of Electrical Machinery
Adapted to Various Purposes
1 2 3 4 5 6 7 8 9 0

RONALDSON CLARENDON

48 POINT

5 A 8 a \$8 35

Rubber SHOES

36 POINT

6 A 10 a \$7 00

HONEST Merchant

30 POINT

8 A 16 a \$6 05

STARVATION Stoppage for Luncheon

24 POINT

10 A 20 a \$5 00

SUGAR Maple Region

18 POINT

14 A 28 a \$4 65

WEDDINGS Joyous Occasions

12 POINT

22 A 45 a \$3 95

REFORMATION Honest Officials Accept Public Trusts

10 POINT

25 A 50 a \$3 55

EXAMINATIONS Application Blanks Mailed Gratuitously

8 POINT

30 A 60 a \$3 45

POLITICAL PROBLEM Discovering Methods to Secure Rapid Postal Service 1234567890

6 POINT

36 A 70 a \$3 35

EXPOSTULATING CITIZENS Freeholders and Taxpayers Combined Grand Mass Meeting 1234567890

OLD STYLE ANTIQUE No 112

48 POINT

4 A \$5 00

FLORIDA

42 POINT

5 A \$4 80

PRINTERS

36 POINT

7 A \$4 50

PREVENTED

24 POINT

10 A \$3 75

FOREST SCENES

20 POINT

12 A \$3 15

WEEKLY SPECIMEN

18 POINT

14 A \$2 45

STEAMBOAT EXCURSIONS

12 POINT

18 A \$1 80

UNIVERSAL PRINTING MACHINE

1246780

CONDENSED SERIES

*72 POINT No 45

5 A \$9 85

PROMOTER

48 POINT No 124

4 A \$4 05

TRADE RISKS

42 POINT No 124

5 A \$2 90

PRECISE CORNERS

36 POINT No 124

6 A \$2 70

FOUNDRY

30 POINT No 124

10 A \$2 80

LAUGHING

24 POINT No 124

12 A \$2 20

LEGISLATIVE

18 POINT No 124

16 A \$2 00

GUITAR CONCERT

16 POINT No 123

18 A \$2 00

ROAMING HERMIT

12 POINT No 124

24 A \$1 85

COUNTRY MEADOWS

11 POINT No 124

24 A \$1 50

PROVISIONS FOR ARMY

10 POINT No 124

24 A \$1 35

UNDECIPHERABLE NOTES

8 POINT No 124

24 A \$1 15

PICTURESQUE MANSION BUILT
1234567890

6 POINT No 124

36 A \$1 30

HERBACEOUS TREES AND SHRUBBERY
1234567890

TWO-LINE LETTER

48 POINT No 35

5 A \$5 00

TRIBUNES

40 POINT No 35

5 A \$4 65

SPECIMENS

36 POINT No 35

6 A \$3 80

CHOIR

30 POINT No 124

12 A \$4 50

HONEST

24 POINT No 124

12 A \$3 40

DUTIFUL

22 POINT No 124

12 A \$2 80

BELIEVED

20 POINT No 124

12 A \$2 70

RARE GEMS

18 POINT No 124

12 A \$2 15

TIGER SHOW

16 POINT No 124

16 A \$2 25

BRIGHT GIRL

14 POINT No 124

18 A \$2 20

FINE SCENERY

12 POINT No 124

24 A \$2 10

MARKET REPORT

11 POINT No 124

24 A \$1 75

PRINTING MACHINE

10 POINT No 124

24 A \$1 55

CHAPEL MEETING 23

9 POINT No 124

24 A \$1 35

CLEAN PROOFSHEETS 38

TWO-LINE LETTER No 129

24 POINT

8 A \$2 10

COUNTRY

18 POINT

12 A \$1 90

HOT DRINKS

16 POINT

12 A \$1 50

HAIL STORMS

12 POINT

16 A \$1 50

WOUNDED MAN

11 POINT

16 A \$1 35

OCEAN STORM 89

10 POINT

22 A \$1 50

WRITING PAPER 64

TWO-LINE LETTER No 128

16 POINT

16 A \$2 30

DISPOSED PRINTING MACHINE

14 POINT

18 A \$2 20

LIGHT RUNNER

12 POINT

24 A \$2 20

KLONDIKE MINE

11 POINT

24 A \$1 95

FOREIGN POLITICS

10 POINT

24 A \$1 60

ORCHESTRAL MUSIC

HALF TITLE SERIES

6 POINT No 120

18 A \$2 95

TIMELY HIT

14 POINT No 120

18 A \$2 45

SIMPLE CASE

12 POINT No 120

24 A \$2 50

LODGE ROOMS

11 POINT No 120

24 A \$2 15

SHORT MEASURE

10 POINT No 120

24 A \$1 70

MOUNTAIN RANGES

8 POINT No 122

16 A 32 A \$2 30

**WELCOME PROOFSHEETS
FORWARDED BY GAIL & SMITH**

8 POINT No 120

32 A \$1 85

**MACHINE DEPARTMENTS
1234567890**

6 POINT No 120

48 A \$2 10

**REMARKABLE CONTINGENCIES
1234567890**

TWO-LINE No 151

24 POINT

10 A \$3 00

MENDER

20 POINT

10 A \$2 50

UTENSILS

18 POINT

11 A \$2 25

PREMIERS

16 POINT

12 A \$2 00

RECORDER

14 POINT

14 A \$2 00

BRIGHT MEN

12 POINT

16 A \$1 75

LIGHT RUNNER

10 POINT

16 A \$1 50

**SOUTHERN SPRINGS
1234567890**

9 POINT

18 A \$1 50

**PUGILISTIC STRUGGLE
1234567890**

LIGHT-FACE No 158

30 POINT

7 A 8 a \$5 00

INTERESTING
Guaranteed Securities

24 POINT

8 A 12 a \$4 50

GREAT BORES
Tunnels through Hoosac

20 POINT

12 A 16 a \$4 00

SLEIGH RIDING
Invigorating and Exhilarating

18 POINT

15 A 20 a \$3 50

GENEROUS PEOPLE
Distributing Charity Unsparingly

12 POINT

20 A 30 a \$3 25

ROUGH-SHOD
Jumping over Streams

10 POINT

24 A 32 a \$3 00

COMPLIMENTARY
Third Annual Excursion

8 POINT

24 A 36 a \$2 75

PARENTAL PHYSIC
Spring Woodshed Exercises
1234567890

6 POINT

30 A 40 a \$2 50

MODERN LEGISLATION
Protecting Corporation Monopolies
1234567890

UNIVERSITY SERIES

18 POINT

9 A 20 a \$3 50

DIAMONDS LOCATED IN BOHEMIA

An interesting publication has been made of the discovery of diamonds in Bohemia, in the garnet sands of Dlaschkowitz, on the estate of Count Schonborn, situated at about four 18

12 POINT

12 A 28 a \$3 00

WINES IMPROVED BY ELECTRIC CURRENTS

Mr. Scouteten, in a recent announcement, renews his assertion that a current of electricity passed through wines exercises a very positive influence in ameliorating and improving them, and refers the alteration to the decomposition of the tartrate of potassa by the electric current. The potassa set free neutralizes the acid of the wine, while the tartaric acid combines with its matter 2390

10 POINT

16 A 36 a \$2 75

AVOID DECEIT AND ABUSE

It is astonishing how people persist in practicing deceit. It is the most detestable and vicious agency that can be used in human intercourse. Men in all conditions of life, the lowest as well as the highest, despise and abhor it as an adder. You may slander, abuse and beat 184

8 POINT

20 A 44 a \$2 75

METALS COATED WITH NICKEL

Much interest was experienced at the Academy of Science in Paris, some time since, by the exhibition of various specimens of metallic articles which were electro-plated with nickel by the new process of Mr. Adams, of Boston. This application of nickel is very likely to be of the greatest value from an industrial point of view since the metal thus deposited has a 765

BOLDFACE SERIES

* 48 POINT No 114

4 A 4a \$6 30

KING Rulers

* 36 POINT No 114

4 A 8a \$5 20

Banker CONVICT

30 POINT No 120

6 A 12a \$5 25

**FARM MACHINERY
Saves Granger Labor**

24 POINT No 120

10 A 20a \$4 85

**GREAT MEN
Cuba Liberty**

18 POINT No 120

12 A 24a \$4 55

**MICROSCOPIC
Beautiful Stars**

12 POINT No 120

12 A 24a \$2 60

**LAUGHING GIRLS
Snow Covered Walk**

11 POINT No 120

18 A 36a \$2 90

**SURPRISED SOLDIERS
Wounded Heads Dressed**

10 POINT No 120

18 A 36a \$2 80

**AMERICAN TRIUMPHS
Move Victorious Onward**

9 POINT No 120

24 A 48a \$3 00

**BRILLIANT DECORATION
Great Tri-Annual Horse Show**

8 POINT No 120

24 A 48a \$3 10

**IMPROVED SHOEMAKING
Fashionable Ladies Footwear**

7 POINT No 120

24 A 48a \$2 60

**ANNUAL CALEDONIAN SPORTS
Blooded Steed Blue Ribbon Parade**

6 POINT No 120

24 A 48a \$2 30

**UNEARNED FORTUNES ACQUIRED
Bold Liberty Enlightening the World
1234567890**

5½ POINT No 120

24 A 48a \$2 65

**SAVED THROUGH MANY BATTLES
Multitudes Encored Famous Generals
1234567890**

FULL FACE No 123

48 POINT

3 A 6 a \$9 20

BEAR Meat

42 POINT

4 A 8 a \$6 80

Great KENNEL

30 POINT

6 A 12 a \$5 80

NATIONS Admired

24 POINT

8 A 16 a \$4 70

Hero Then PRACTICES

18 POINT

10 A 20 a \$4 25

**PROMOTED
River Pirates**

14 POINT

12 A 24 a \$3 40

**SHORT NIGHT
Longer Evening**

12 POINT

12 A 24 a \$2 60

**LITTLE CRUMBS
American Heroism**

11 POINT

18 A 36 a \$2 95

**SPANISH RESOURCES
Sandbanks of Santiago**

10 POINT

18 A 36 a \$2 75

**MAGNETIC MACHINES
Attract Great Attention**

9 POINT

18 A 36 a \$2 55

**REPUBLICAN DOCTRINE
Proclaiming Emancipation**

8 POINT

24 A 48 a \$3 25

**FINE ART EXHIBITION
Postal Information Guides**

7 POINT

24 A 48 a \$2 80

**RETURNED SOLDIERS GIFT
Rejoicing at Family Reunions**

6 POINT

24 A 48 a \$2 55

**SPORTIVE DEMONSTRATIONS
Memorable Scenes are Reproduced
1234567890**

5 1/2 POINT

24 A 48 a \$2 75

**RAILROAD FREIGHT CONTRACT
Cornmeal, Wheat and Rye Shipments
1234567890**

BOLDFACE ITALIC No 120

30 POINT

6A 12a \$4 55

AMERICAN Knowledge

24 POINT

10A 20a \$4 55

***HONEST PROCLAMATION
Cuban Insurgents Dissatisfied***

18 POINT

12A 24a \$3 90

***PICKPOCKETS
Hunting Steamer***

12 POINT

12A 24a \$2 65

***OCEAN STEAMER
Flagship New York***

11 POINT

18A 36a \$3 05

***MEXICAN SOLDIERS
Raised Window Curtain***

10 POINT

18A 36a \$2 90

***GOVERNMENT BOND
Relating many Incidents***

9 POINT

24A 48a \$2 95

***REVENUE COMMISSIONER
United States Treasury Notes***

8 POINT

24A 48a \$3 00

***DESPERATE ENCOUNTER
Volunteers and Spanish Troops***

7 POINT

24A 48a \$2 55

***PERFECTLY WELL SATISFIED
With Constitutional Amendments
1234567890***

6 POINT

24A 48a \$2 25

***RESTORING PUBLIC CONFIDENCE
Delay Republican National Convention
1234567890***

FULL FACE ITALIC No 123

12 POINT

12A 24a \$2 65

***DOWN THE LITTLE WORN PATH
Several Breakneck Contortions Performed***

11 POINT

18A 36a \$3 30

***STOUT STRANGERS
Prospecting For Gold***

10 POINT

18A 36a \$3 20

***CELEBRATED MAN
Exceedingly Heartless***

9 POINT

18A 36a \$2 65

***TWELVE OLD TIGERS
Escaped Alone at Midnight***

8 POINT

18A 36a \$2 60

***LABOR DAY PARADES
Marching To Sweet Music***

6 POINT

24A 48a \$2 60

***WIND BLOWETH STRONGLY
Down the Mossgrown Woodpath
1234567890***

5½ POINT

24A 48a \$2 65

***WHERE RIVER GENTLY FLOWS
Angry Waves Dashing Madly Past
1234567890***

OPEN TITLE No 120

16 POINT

12 A 24 a \$3 65

EXTENSIVE FARMING DISTRICT

Developing Tremendous Resources

12 POINT

12 A 24 a \$2 55

REFRIGERATORS

Beautiful Products

10 POINT

18 A 36 a \$2 90

PROPHETIC EXPERT

Fashionable Street Cars

8 POINT

24 A 48 a \$2 95

REMODELED MACHINERY

Severely Condemned Makers

6 POINT

24 A 48 a \$2 20

ENTERING DESPERATE BATTLE

Severely Condemned Election Tactics

1234567890

11 POINT

18 A 36 a \$3 00

FRIVOLOUS NOTION

Dramatic Society Circle

9 POINT

24 A 48 a \$2 85

INFORMATION BUREAUS

Applicants Furnished Works

7 POINT

24 A 48 a \$2 25

SPLENDID CREAMERY BUTTER

Farmer Receiving Handsome Flowers

5½ POINT

24 A 48 a \$2 00

GUARDING WESTERN MINING CLAIM

United States Internal Revenue Department

1234567890

CONDENSED TITLE No 124

14 POINT

18 A 36 a \$3 70

PRESIDENT GRANT

Smoked Havana Cigar

11 POINT

18 A 36 a \$2 80

FASCINATING MAIDENS

Marching Through Georgia

9 POINT

24 A 48 a \$2 75

TIRED HARVESTING HAND

Reading Papers By Candlelight

7 POINT

24 A 48 a \$2 05

HAPPY AND CONTENTED HUSBAND

Discovered Roadbed For Baby Carriages

1234567890

12 POINT

18 A 36 a \$3 05

HARDWOOD BOUGHT

Splendid For Buildings

10 POINT

24 A 48 a \$3 30

PLEASANT SITUATIONS

Escaping Fast and Furious

8 POINT

24 A 48 a \$2 50

COLORED TROOPS MARCHING

Along the Rough and Stony Roads

6 POINT

24 A 48 a \$2 05

SO YANKEE DOODLE CAME TO TOWN

Remarkable and Extraordinary Incident

1234567890

CONDENSED TITLE

*72 POINT No 46

5 A 6 a \$16 95

Sister MINE

60 POINT No 125

3 A 6 a \$8 35

ROMEO Juliet

48 POINT No 125

4 A 8 a \$6 40

CURRENT EVENTS
Caused Much Dread

36 POINT No 125

8 A 16 a \$6 60

AFTER DISHONEST MEN
Deception of Fair Widows

30 POINT No 125

10 A 20 a \$4 90

ANNIHILATE YOUR ENEMIES
Instruct Unsophisticated Maidens

CONDENSED TITLE

24 POINT No 125

12 A 24 a \$4 00

WINTER SWEETS
Shall Bloom Again

14 POINT No 125

18 A 36 a \$3 25

EXCURSION TICKET
Stew or Fry to Order

11 POINT No 125

18 A 36 a \$2 40

MARRIAGE ANNIVERSARY
Enjoyed by Eloquent Tramp

9 POINT No 125

24 A 48 a \$2 50

HOME IMPROVEMENT SOCIETY
Attended by Bachelors and Maids

7 POINT No 125

24 A 48 a \$2 00

WHERE THE FLOWERS BLOOM LOVE
Excellent Opportunity for New Beginners
1234567890

18 POINT No 125

12 A 24 a \$3 25

AFTER THE TIME
Many Hearts Aching

12 POINT No 125

18 A 36 a \$2 75

REMEMBER THE MAINE
Hypocrisy and Deceptions

10 POINT No 125

24 A 48 a \$3 00

NEW YORK BUCKET SHOPS
Bombproof Sailors Cheering

8 POINT No 125

24 A 48 a \$2 55

COMES MARCHING HOME AGAIN
This is the Fall of Our Discontent

6 POINT No 125

24 A 48 a \$2 05

WINTER EVENINGS PASSED AT HOME
Tremendous Cacklings Before Daybreak
1234567890

CONDENSED TITLE No 104

28 POINT

14 A 20 a \$6 30

Twentieth WEDDING Anniversary

22 POINT

14 A 27 a \$4 60

Annihilates GEESE

12 POINT

25 A 52 a \$3 65

SLANG PHRASES
Verbiage for City Councilmen

8 POINT

36 A 70 a \$3 25

HYPOCRISY AND DECEPTION
Stepping Stones for the Unscrupulous
1234567890

18 POINT

18 A 27 a \$3 55

Crowded STORE in Paris

10 POINT

36 A 70 a \$3 85

SOCIAL NUISANCES
Constantly Growling Neighbors

6 POINT

36 A 70 a \$2 60

FELONIOUSLY ABSTRACTED
The Only Personal Property of the Advertiser
1234567890

CONDENSED TITLE No 123

*54 POINT

4 A 5 a \$8 00

TIRE Makers

*48 POINT

4 A 6 a \$7 00

Minstrel **SONG**

42 POINT

5 A 10 a \$7 55

FISHING Tackles

36 POINT

6 A 12 a \$7 15

Army **MUSTERING**

30 POINT

8 A 16 a \$5 50

PRINTERS Help Improve

24 POINT

12 A 24 a \$4 75

Scholars **WENT**

18 POINT

10 A 20 a \$3 05

Retailed **IMPORT**

14 POINT

12 A 24 a \$2 80

STEAMERS Discover

12 POINT

18 A 36 a \$3 10

SAILOR On Stormy Sea

10 POINT

24 A 48 a \$2 95

LAUGHABLE PERFORMER
Tired People Form Company

8 POINT

24 A 48 a \$2 50

SUMMER FRUITFUL RIPENING
Wasted Occasion during Springtime

6 POINT

24 A 48 a \$1 95

ASTONISHING TYPOGRAPHIC INVENTION
Great Schemes Receive Liberal Endorsements
1234567890

5 POINT

32 A 64 a \$2 40

ARMIES MUST NOT EXCEED FOURTEEN HUNDRED MEN
Very Doubtful Circumference of the Terrestrial Sphere
Economical Democratic State Convention
1234567890

CONDENSED ALDINE No 150

72 POINT

4 A 6 a \$8 00

GRAND Health Tonics

60 POINT

5 A 7 a \$7 00

Pleasant Summer NIGHT

48 POINT

6 A 10 a \$6 30

Uniform EXCHANGE Measure

36 POINT

10 A 15 a \$6 00

BANK Discount

30 POINT

10 A 15 a \$4 00

Gymnastic POINTS

20 POINT

12 A 16 a \$4 00

Potomac River BRIDGE

18 POINT

18 A 26 a \$4 00

MARBLE Heart Fire Engine

14 POINT

18 A 26 a \$3 75

HONEST BOY Advocate Principle

12 POINT

22 A 32 a \$3 50

Printer Observe GOOD MANUSCRIPT

11 POINT

24 A 36 a \$3 00

**UNIQUE POSTERS DESIGNED
Special Poster and Painting Exhibition**

10 POINT

24 A 36 a \$3 00

**WHERE SNEAKS DOMINATE
Decent Men Should Assert Their Rights**

9 POINT

24 A 36 a \$2 90

**THE STAR-SPANGLED BANNER
Message of Freedom Proclaimed to Mankind**

8 POINT

26 A 38 a \$2 80

**SKILLFUL POLITICAL WIRE PULLERS
Again Deceiving Voters by Meaningless Phrases**

7 POINT

36 A 50 a \$2 25

**PROFESSIONAL TAMBOURINE SERENADERS
Great Authors were Present from Australia and Europe
1 2 3 4 5 6 7 8 9 0**

6 POINT

30 A 60 a \$2 00

**HARD TIMES BEGET DEEP THOUGHTS
History Bears Witness as to the Veracity of Above Statement
1 2 3 4 5 6 7 8 9 0**

EXTRA CONDENSED

23-12

120 POINT NO 234

3A 6a \$12 50

BRIGHT and Sordid

96 POINT NO 234

4A 8a \$11 00

Klondike Miners FROZEN

72 POINT NO 234

5A 10a \$10 50

HUNDRED Beautiful Women

48 POINT NO 123

4A 8a \$5 80

DISCOVERY OF GOLD MINE
Where the Robins Nest Safely

EXTRA CONDENSED

42 POINT NO 123

5 A 10a \$4 80

LOVING MOTHER SENDS BLESSING
Home Conventions Profusely Decorated

36 POINT NO 123

6 A 12a \$4 70

INVOLVED MANY WEIGHTY QUESTIONS
Particular Parliamentary Document Destroyed

24 POINT NO 123

8 A 16a \$3 65

HAPPY MAIDENS WELCOME MORNING GLORIES
Sunrise Rays Impart Lovely Blushes to Dimpled Cheeks

20 POINT NO 123

10 A 20a \$3 10

REPUBLICAN GOVERNMENTS
Industrious Mechanics Wanted

18 POINT NO 123

12 A 24a \$3 00

ELASTIC ANTI-FRICTION MORALS
Bachelors Wanted to Matrimonialize

14 POINT NO 123

12 A 24a \$2 55

BREAKFAST TABLE MANIPULATION
Demanding Delicious California Oranges

12 POINT NO 123

16 A 32a \$2 65

ASSEMBLING OF INDUSTRIOUS LADIES
Good Recipes for Curing Fever Epidemics

* 10 POINT NO 123

30 A 40a \$3 10

NORTHERN STATES INTERNATIONAL EXPOSITION
Contemplating Miscellaneous Telescopic Observations
1234567890

* 8 POINT NO 123

40 A 50a \$3 50

AUTOCRATIC MILLIONAIRES PURCHASING GOLD BONDS
Magnificent Catalogues Announcing Good Winter Commodities
1234567890

ROMAN EXTENDED No 120

36 POINT

4 A 8a \$5 75

RAMBLE
From Here

30 POINT

5 A 10a \$5 85

INDUSTRIAL
Great Bargains

24 POINT

6 A 12a \$5 40

HOUSEHOLDS
Memorial Service

18 POINT

8 A 16a \$5 10

VIOLET
Stray Cat

12 POINT

12 A 24a \$3 70

HIGH TIME
Cranky Player

10 POINT

12 A 24a \$2 50

RICH WIDOWS
Designing but Cute

9 POINT

16 A 32a \$2 75

DELIGHTFUL RIDE
Scented With Flowers

8 POINT

18 A 36a \$3 05

HONORED KNIGHT
Deserves Great Credit

6 POINT

18 A 36a \$2 30

DARKEST BEFORE DAY
Makes Hay When Sun Shines

5 1/2 POINT

24 A 48a \$3 05

COMES MARCHING ALONG
Twenty Thousand Brave Tramps
1234567890

5 POINT

24 A 48a \$3 40

5 POINT ON 6 POINT

24 A 48a \$2 70

SHORT CUT FASHIONABLE
Tonsorial Artist Gleefully Grins
1234567890

TITLE EXPANDED No 120

48 POINT

3 A 5 a \$11 55

SIDney

42 POINT

3 A 5 a \$8 60

**FENCED
Pet Lions**

36 POINT

3 A 6 a \$5 60

**NILE
Smile**

24 POINT

4 A 8 a \$4 15

**MEAD
Forced**

20 POINT

6 A 12 a \$4 35

**BLIGHT
Judge Nit**

18 POINT

6 A 12 a \$3 15

**DIVORCE
Fine as Silk**

12 POINT

10 A 20 a \$2 80

**FINE HOUSE
Painted in Blue**

10 POINT

12 A 24 a \$2 50

**SWEEP CLEAN
Cyclone in Kansas**

9 POINT

18 A 36 a \$3 10

**CURRENT REPORT
Floating on the Breeze**

8 POINT

18 A 36 a \$3 10

**BRIGHT PROSPECT
Solicited for the Trade**

6 POINT

18 A 36 a \$2 65

**INDEPENDENT FIRMS
Supreme Court Decisions
1234567890**

5½ POINT ON 6 POINT

24 A 48 a \$3 05

5½ POINT

24 A 48 a \$3 50

**NATIONAL MISFORTUNE
Viewed by Distressed Soldier
1234567890**

IONIC No 150

48 POINT

3 A 5 a \$7 00

TRUE Colors

42 POINT

5 A 6 a \$6 00

Inexorable JUDGE

36 POINT

6 A 10 a \$5 00

GRACEFUL Benefactor

24 POINT

7 A 11 a \$4 00

ROMAN ASCETICS
Scorned Culinary Pleasures

20 POINT

10 A 16 a \$3 50

ARTISTIC IMPROVEMENTS
Performances Warmly Complimented

12 POINT

17 A 28 a \$3 00

ORIGINAL IDEA
Deserved Recognition

10 POINT

22 A 32 a \$2 75

STRICTEST ECONOMY
Necessary for City Legislators

8 POINT

24 A 36 a \$2 50

ENGLISH ARCHITECTURE
Wanderings Through Southampton
1234567890

6 POINT

30 A 45 a \$2 25

GOVERNMENT RAILROAD SERVICE
Unsurpassed Facilities for Handling Materials
1234567890

IONIC SERIES

* 48 POINT NO 30

4 A 6 a \$8 90

RICH Lands

* 42 POINT NO 159

4 A 5 a \$6 40

Liberal TERM

36 POINT NO 122

4 A 8 a \$5 20

PRODUCTS
Siberian Diamonds

30 POINT NO 122

6 A 12 a \$4 90

SHIPS
Cool Trips

24 POINT NO 122

8 A 16 a \$4 70

SILENT
Prison Halls

18 POINT NO 122

10 A 20 a \$3 70

INDIANA
National Queen

12 POINT NO 122

16 A 32 a \$3 15

REPRIMANDS
Social Reformations

10 POINT NO 122

18 A 36 a \$2 60

SOCIAL LEADERS
Great Annual Horse Show

8 POINT NO 122

24 A 48 a \$2 60

FASHION EXHIBITION
Grand Display of Gotham Beauty

6 POINT NO 122

24 A 48 a \$2 30

BRILLIANT DECORATION
Blue Ribbon Parade of Blooded Steeds
1234567890

5 POINT NO 122

24 A 48 a \$2 60

ANNUAL CALEDONIAN GAMES
Rosy Cheeked Maids in the Matrimonial Race
1234567890

IONIC SERIES

48 POINT No 122

3 A 6 a \$10 25

FISHING
Companies

42 POINT No 122

3 A 6 a \$7 15

DAMAGING
Fine Harvest

36 POINT No 120

6 A 12 a \$7 70

HANDY
Carriage

24 POINT No 120

10 A 20 a \$5 65

CURTAINS
Fine Design

18 POINT No 120

18 A 32 a \$4 90

STRONG WIND
Wheat Destroyed

12 POINT No 120

18 A 36 a \$3 65

DARING SCOUTS
Famous Publication

10 POINT No 120

18 A 36 a \$3 05

WINSOME MAIDENS
Sunshine After Storms

8 POINT No 120

24 A 48 a \$3 10

MOURNED BY MILLIONS
When Did The Dead Sea Die

6 POINT No 120

24 A 48 a \$2 50

EQUINE SAGACITY OBSERVED
Feline Trainers Amusing Audience
1234567890

5 1/2 POINT No 120

24 A 48 a \$2 55

MAGNIFICENT AMERICAN FARMS
Are in Evidence East West North South
1234567890

ANTIQUE SERIES

* 72 POINT NO 124

3 A 4 a \$14 15

Her SIN

60 POINT NO 42

5 A 6 a \$15 60

FIR Grove

48 POINT NO 124

3 A 6 a \$8 40

Cared SURE

42 POINT NO 124

4 A 8 a \$7 50

SILver

36 POINT NO 124

5 A 10 a \$5 05

BIG Plot

30 POINT NO 124

6 A 12 a \$4 55

Note COIN

24 POINT NO 124

10 A 20 a \$4 80

High STONE

18 POINT NO 124

12 A 24 a \$4 00

MEAN HABITS
Contains Arsenic

12 POINT NO 124

18 A 36 a \$3 40

TICKET OPERATOR
Northwestern Routes

10 POINT NO 124

18 A 36 a \$2 60

INSURGENT PRISONER
True American Generosity

8 POINT NO 124

24 A 48 a \$2 90

LIFE INSURANCE POLICIES
Commercial Printing done here

6 POINT NO 124

24 A 48 a \$2 35

INTRODUCING NEW MACHINES
Disregard Some Questionable Methods
1234567890

5 POINT NO 124 ON 6 POINT

24 A 48 a \$1 85

DEMANDING A THOROUGH RESEARCH
Two Independent Philadelphia Manufacturers
1234567890

ANTIQUÉ No 125

48 POINT

4 A 8 a \$9 35

FINE Horse

36 POINT

5 A 10 a \$7 90

Perilous RIDE

30 POINT

6 A 12 a \$5 80

Gray MOON Dogs

24 POINT

8 A 16 a \$4 70

UNIFORM OVERCOATS
Modern Trousers Imported

18 POINT

12 A 24 a \$4 45

REPUTATION
Honest Morals

12 POINT

18 A 36 a \$3 20

BEAUTIFUL LADIES
Evening Concert Given

10 POINT

24 A 48 a \$3 05

MEXICANS CONVERTED
Political Courage Uprising

9 POINT

24 A 48 a \$3 05

DRINKING LIGHT LIQUOR
Brightest Hopes are Fleeting

8 POINT

24 A 48 a \$2 80

CURIOUS HISTORICAL ITEM
Don't Roam Around the House

7 POINT

24 A 48 a \$2 25

EASTERN CARTILAGINOUS FISHES
Comprehend European Disintegration

6 POINT

24 A 48 a \$2 30

DETERMINED MECHANICS STRIKE
Peace Reigns Throughout the World
1234567890

5½ POINT

32 A 64 a \$2 95

DISCERNING COMMENTATORS APPROVED
Numerous Excellent Graduated Nutriment
1234567890

ANTIQUE No 126

36 POINT

6 A 12 a \$6 00

EXTREME LABOR
International Brands

24 POINT

10 A 20 a \$4 00

FOSSILIZED MONUMENT
Celebrated Popular Statesmen

18 POINT

12 A 24 a \$3 00

DELIGHTFUL HOLIDAY MEMORIES
Able Statesmen Assembled in Conference

12 POINT

16 A 32 a \$2 50

ENTHUSIASTIC AUDIENCE BECAME RESTLESS
Autocratic Millionaires Purchasing Government Bonds

11 POINT

16 A 32 a \$2 20

STEREOTYPING DISPLAYS
Celebrated Historical Teacher

10 POINT

18 A 36 a \$2 35

KINDHEARTED GARDENER
Grave Diplomatic Statements

9 POINT

18 A 36 a \$2 10

COUNCILMANIC DEPARTMENT
Unscrupulous Counterfeit Method
Reversible Seamless Spring Coats

8 POINT

20 A 40 a \$2 25

DISPLAY WONDERFUL NERVE
Rocked in the Cradle of the Deep
Pensioning Wounded Combatants

6 POINT

24 A 48 a \$2 15

HEARTRENDING APPEALS TO PATRIOT
Zealously Guard Contagious Localities
Contributions from Patriotic Volunteer
Entertainments in Gymnastic Contests

5½ POINT

24 A 48 a \$2 00

REINVIGORATE DEPOPULATED NATIONALITIES
Sweet Voices Singing Requiems Over the Departed
Suburban Residences Destroyed by the Tidal Wave
Revised Histories of Celebrated Discoveries Finished

1234567890

1234567890

CENTRAL ANTIQUE

54 POINT

3 A 5 a \$10 00

BIG Hens

48 POINT

3 A 5 a \$8 00

Dark RIDE

42 POINT

4 A 6 a \$7 00

GEMS Bound

36 POINT

4 A 6 a \$5 00

Enrich MISERS

30 POINT

5 A 8 a \$4 50

SIX Men

24 POINT

6 A 10 a \$4 00

DISH Cloth

18 POINT

10 A 16 a \$3 25

Danish SONG

14 POINT

14 A 20 a \$3 00

Trained HORSES

12 POINT

18 A 22 a \$3 00

GERMAN DANCERS
Excite Society Maiden

10 POINT

22 A 30 a \$2 75

BOSTON CONCERT GIRLS
Unique Amusement Created

8 POINT

24 A 36 a \$2 50

ENTHUSIASTIC KLONDIKERS
Return Sadder but Wiser Miners

6 POINT

30 A 42 a \$2 25

FROLICHSOME EUCHRE COMPANIONS
Escorts Delighted with Buxom Partners

1234567890

1234567890

LINING ANTIQUE SERIES

36 POINT No 40

6 A \$4 50

CHECKERED

30 POINT No 40

8 A \$3 80

PREMIERSHIPS

24 POINT No 40

10 A \$3 20

TRANQUIL WOMEN

18 POINT No 40

14 A \$2 55

FRAGRANT PERFUMERY

12 POINT No 40

25 A \$2 25

HEALTHY
SMILING FACES

10 POINT No 40

30 A \$2 00

EXCURSION
LARGE STEAMSHIP

8 POINT No 40

36 A \$2 00

FAMILY ACROBATS
PITCHER AND TUMBLER

6 POINT No 45

45 A \$1 90

ANNUAL GATHERING
MUTUAL ADMIRATION SOCIETY

6 POINT No 44

45 A \$1 60

LIBERAL COMPENSATION
ALLOWED FOR ADVERTISING SURFACE
FENCES PREFERRED

6 POINT No 43

45 A \$1 30

APPROACHING DESTINATION
AGED VETERANS IN THE WARFARE OF LIFE
CONTENTED TRAVELERS

6 POINT No 42

45 A \$1 15

INDUSTRIAL DEPARTMENT
EMPLOYING BUSY BRAINS AND ACTIVE MUSCLES
IMPROVED TOOLS AND IMPLEMENTS
1234567890

6 POINT No 41

45 A \$1 10

NOTEWORTHY OCCURRENCES
MATRIMONIAL VOWS AND ADVENT OF THE FIRST-BORN
SUMMER VISITS TO COUNTRY COUSINS
1234567890

ANTIQUE CONDENSED

36 POINT No 152

6 A 10 a \$5 00

Grand EUCHRE Parties

30 POINT No 152

8 A 12 a \$4 50

NEW Scorer

24 POINT No 152

10 A 14 a \$4 00

QUICK Games

20 POINT No 152

12 A 16 a \$3 50

Exultant MAIDS

18 POINT No 122

12 A 24 a \$3 50

Celebrated SINGER

12 POINT No 122

18 A 36 a \$2 85

GENUINE Scotch Texture

10 POINT No 122

24 A 48 a \$2 85

RENOWNED French Landscape

8 POINT No 122

24 A 48 a \$2 35

Enterprising American COMEDIANS

1234567890

6 POINT No 122

24 A 48 a \$1 90

Manufacturer Advances SOUND ARGUMENT

1234567890

ANTIQUE No 127

24 POINT

8 A 16 a \$5 45

DEPOSED Renegades

18 POINT

10 A 20 a \$3 90

Paying Positions CAPTURED

12 POINT

16 A 32 a \$2 95

GREAT MEMORIES

Experience Required

11 POINT

16 A 32 a \$2 45

DISCOURAGE TRAMPS

Throughout the Universe

10 POINT

18 A 36 a \$2 70

BRIGHTEST CHANCES

Produced Without Favor

9 POINT

18 A 36 a \$2 05

FAMISHED RECRUITS PERISH

Lost By Erroneous Calculations

8 POINT

24 A 48 a \$2 70

NEARING DESTROYED PARK

Multiplied Submarine Disorders

1234567890

6 POINT

24 A 48 a \$2 30

THOUSANDS DISCUSSED RETURNS

Severely Criticised Monroe Doctrine

1234567890

ANTIQUE CONDENSED

72 POINT NO 122

3 A 5 a \$10 00

Clear RED Inks

60 POINT NO 122

3 A 6 a \$7 25

Denver GOLD Mine

48 POINT NO 122

4 A 8 a \$5 50

Northern INTERESTS

36 POINT NO 122

6 A 12 a \$5 45

SEVENTH Entertainment

30 POINT NO 122

8 A 16 a \$4 65

STATE Prison

24 POINT NO 122

10 A 20 a \$3 65

GRAND Concerts

18 POINT NO 116

15 A 24 a \$2 90

National COLLEGES

14 POINT NO 116

16 A 30 a \$2 85

Northern HOMESTEADS

12 POINT NO 116

20 A 30 a \$2 55

STANDARD LETTER
Excellent Condensed Series
1234567890.

10 POINT NO 116

24 A 50 a \$2 70

GREAT FOREST LANDS
North American Lumber District
1 2 3 4 5 6 7 8 9 0

ANTIQUE EXTRA CONDENSED No 150

* 96 POINT

12-16

3 A 4 a \$10 85

FOREIGN Homes

72 POINT

3 A 5 a \$8 50

Nice TOY

60 POINT

4 A 6 a \$6 50

Lonely SUIT

48 POINT

4 A 7 a \$5 00

OPERA Cloaks

42 POINT

5 A 8 a \$4 50

ELEGANT GOWN

36 POINT

7 A 11 a \$4 25

Pinafores BRAIDED

30 POINT

9 A 12 a \$4 00

Yachting COSTUME

24 POINT

11 A 17 a \$3 75

ADVERTISED Underwear

20 POINT

10 A 16 a \$3 50

STUPENDOUS Importation

18 POINT

14 A 20 a \$3 25

Choicest EMBROIDERY Bargain

12 POINT

16 A 26 a \$3 00

Desirable HANDKERCHIEF Novelties

10 POINT

20 A 32 a \$2 75

ENAMELED Limoges or English PORCELAIN
1 2 3 4 5 6 7 8 9 0

8 POINT

22 A 32 a \$2 50

COMPULSORY Disposals of Magnificent FURNITURE
1 2 3 4 5 6 7 8 9 0

ANTIQUE CONDENSED No 123

60 POINT

3 A 6 a \$6 55

MOUNTAIN Stream

48 POINT

4 A 8 a \$5 75

Summer FRIENDSHIP

42 POINT

6 A 12 a \$5 55

REPUBLICAN Pyrotechnics

30 POINT

8 A 16 a \$4 40

**COMMUNICATE
Evening Gown**

24 POINT

12 A 24 a \$4 20

**ANCIENT CUSTOM
National Triumph**

18 POINT

12 A 24 a \$3 05

**HANDSOME FLOWERS
Raised in Greenhouse**

16 POINT

12 A 24 a \$2 40

**CONVENTION DELEGATE
Member Securing Ticket**

14 POINT

16 A 32 a \$2 70

**GOOD BUSINESS CHANCES
Between Dark and Morning**

12 POINT

18 A 36 a \$2 30

**FALL OF NAPOLEON TEACHES
European Commanders a Lesson**

10 POINT

24 A 48 a \$2 30

**LATEST STYLES IN LADIES SHOES
Manufactured by the Late John Smith
1234567890**

8 POINT

24 A 48 a \$2 15

**EXTRAORDINARY COURAGE TESTED
Herculean Effort Accomplished Result
1234567890**

ANTIQUE CONDENSED No 124

* 72 POINT

5 A \$3 35

NUT BROWN

60 POINT

4 A \$4 20

EXPORTED RUM

48 POINT

5 A \$3 40

FASHION

42 POINT

6 A \$3 00

SECURING

36 POINT

8 A \$2 55

SERVE MAN

24 POINT

12 A \$2 40

CONTRADICTS

18 POINT

16 A \$2 30

ORNAMENTATION

16 POINT

18 A \$1 75

CAPTURE BOLD BAND

14 POINT

18 A \$1 40

REGULAR BAKING HOUR

12 POINT

24 A \$1 45

ESTABLISHED FURNISHER

10 POINT

24 A \$1 25

MAGNIFICENT MONOCHROMES
1234567890

8 POINT

24 A \$1 00

BEAUTIFUL AMERICAN STEAMSHIPS
1234567890

BRETON SERIES

48 POINT

3 A 3 a \$8 00

ICE Boat

40 POINT

3 A 4 a \$5 00

MODERN Frame House

24 POINT

7 A 10 a \$4 00

UNION STATION Great Building Complete

18 POINT

12 A 18 a \$3 25

EUROPEAN COUNTRY Touring in Germany and Scotland

12 POINT

16 A 24 a \$3 00

HIGH BRIDGE Over the Charles River

10 POINT

20 A 30 a \$2 75

BEAUTIFUL SNOW Don't Push those Drifts Away

8 POINT

24 A 36 a \$2 50

RAIN EVERY SUNDAY Laboring Hardly Every Other Day

6 POINT

28 A 42 a \$2 25

DOWN BY THE RIVULET When Summer Comes Creeping Along 1 2 3 4 5 6 7 8 9 0

ANTIQUE EXTENDED No 152

36 POINT

5 A \$7 00

BREAD

30 POINT

5 A \$5 00

HUNTERS

24 POINT

6 A \$3 00

ROSE

20 POINT

8 A \$2 75

TERSE

18 POINT

10 A \$2 60

MEDALS

12 POINT

15 A \$2 25

SHRIMP 12

ANTIQUE EXTENDED No 153

24 POINT

4 A \$3 35

**GOLD MINES
Klondikers 98**

ANTIQUE EXTENDED No 123

12 POINT

16 A \$2 35

MEDICINE COMPOUND

10 POINT

18 A \$2 05

CONFIDANTS

8 POINT

24 A \$2 25

ENCOURAGING

6 POINT

24 A \$1 90

GREAT PRODUCTS
1234567890

5 POINT

24 A \$1 65

RUSHING DOWN GRADES
1234567890

ANTIQUE EXTENDED

—4-12—

48 POINT No 40

3 A 4a \$19 60

RIGS
Made

32 POINT No 40

3 A 4a \$9 70

SHINE
Bright

24 POINT No 120

4 A 8a \$5 75

CHAMOIS
Emigrating

18 POINT No 120

6 A 12a \$5 25

MEND
Ulsters

12 POINT No 120

8 A 16a \$3 95

RICHER
Brothers

10 POINT No 120

12 A 24a \$3 95

WARRING
Musketeers

8 POINT No 120

12 A 24a \$3 20

MANICURING
Hand Remedy

6 POINT No 120

12 A 24a \$2 50

INDIAN SABLES
Farm Hands Short
1284567890

5 POINT No 120

18 A 36a \$3 50

MOONLIGHT EXPOSE
Columbian Exposition Car
1284567890

ANTIQUE EXTENDED No 124

42 POINT

3 A 6 a \$10 40

SENator

30 POINT

4 A 8 a \$6 40

MORE Life

24 POINT

6 A 12 a \$5 45

**TUBES
Finders**

18 POINT

8 A 16 a \$4 45

**FLAMES
Hot Stuff**

12 POINT

10 A 20 a \$3 65

**LIGHTING
Truck Man**

10 POINT

10 A 20 a \$2 75

**STONE JUGS
Sugar Market**

8 POINT

16 A 32 a \$3 30

**EXAMINE WELL
Fashion Reviews**

6 POINT

18 A 36 a \$2 90

**EXAMINATION FREE
Service Questions 234**

ANTIQUE EXTENDED No 122

30 POINT

4 A 8 a \$6 45

**NED
Milk**

24 POINT

5 A 10 a \$5 05

**CUBIC
Dinner**

12 POINT

8 A 16 a \$4 00

**DELPHI
One Run**

10 POINT

10 A 20 a \$3 70

**PRIMERS
Pupils 234**

BROADGAUGE SERIES

40 POINT

5 A \$10 70

HOMES

36 POINT

5 A \$8 85

SON

28 POINT

5 A \$6 10

RUM

22 POINT

7 A \$4 65

FINES

18 POINT

10 A \$5 05

DOINGS

12 POINT

14 A \$4 20

CONCRETE

10 POINT

18 A \$4 05

ORNAMENTS

8 POINT

22 A \$3 80

STEAM HORSES
12345678

6 POINT

25 A \$3 40

MIDNIGHT MUSINGS
1234567890

HARDWARE SERIES

36 POINT

3 A \$5 50

FINED

24 POINT

6 A \$4 15

SUN

18 POINT

6 A \$2 45

HOSE

12 POINT

10 A \$2 10

BRIGHT
12345

10 POINT

10 A \$1 55

RANGERS
123456

CLARENDON No 120

48 POINT

4 A 8 a \$8 30

GRAIN Binder

36 POINT

5 A 10 a \$6 40

Famous FRIENDS

30 POINT

6 A 12 a \$4 15

RIVERSIDE TRAMWAYS Publishing Domestic Trouble

24 POINT

8 A 16 a \$3 35

YOUNG HORSE Becoming Sulky

18 POINT

10 A 20 a \$2 95

CONTRA COSTA Honest Treatment

12 POINT

16 A 32 a \$2 95

GOOD MESSENGERS Wonderful Hardship

11 POINT

16 A 32 a \$2 40

CUBAN INDEPENDENCE Summer Comfort for Guests

10 POINT

18 A 36 a \$2 50

GRASP OPPORTUNITIES Marine Insurance Company

9 POINT

18 A 36 a \$2 00

GRAND FUNDING OPERATION Gigantic Accumulation of Securities

8 POINT

24 A 48 a \$2 50

FEVER IN SANTIAGO DE CUBA Sickly People Forming a Company 1234567890

6 POINT

24 A 48 a \$2 05

CONSTITUTION OF UNITED STATES Wealth Speedily Acquired by Purchasing 1234567890

CLARENDON CONDENSED

60 POINT No 10

3 A 4 a 89 66

Latest **CARD**

48 POINT No 120

4 A 82 80 4 A 8 a 87 60

New **MEN HERE**

42 POINT No 120

5 A 82 35 5 A 10 a 86 55

READY AIM Target

36 POINT No 120 6 A 82 00 6 A 12 a 85 45

**FINE MEN
PAST Event**

30 POINT No 120 8 A 81 60 8 A 16 a 84 65

**PRICE SOME
ORDER Drinks**

24 POINT No 120 10 A 81 30 10 A 20 a 83 60

**CRUSHED PEAR
STOLEN FRUIT
Parlor Destroyed**

18 POINT No 120 12 A 81 00 12 A 24 a 83 00

**NORTHERN HOUSE
WOLVES ATTACHED
Dark Spanish Beauty**

12 POINT No 120 16 A 80 75 16 A 32 a 82 35

**AMERICAN GOLF PLAYER
TOURING THE COUNTRY
Sixteenth Century Women**

1234567890

10 POINT No 120 18 A 80 70 18 A 36 a 82 00

**SOUTHERN COTTON DISTRICTS
EMPLOYED NEGRO LABOR
Noble Deeds Are Quickly Observed**

1234567890

CLARENDON CONDENSED No 122

60 POINT

3 A 6a \$6 05

BEAUTIFUL Shadows

48 POINT

4 A 8a \$5 10

Reasonable FURNISHED

36 POINT

6 A 12a \$3 85

NORTHERN GRAZING RANCH
Marketing Meadow Products 58

24 POINT

8 A 16a \$2 95

ELEGANT DINING
Finest Home Meals

18 POINT

12 A 24a \$2 45

NEWLY INVENTED BOMB
Destroying Torpedo Boats
1234567890

INCLINED ANTIQUE

12 POINT

20 A 30a \$3 50

BUILDING STONE
Fine Residence

10 POINT

25 A 40a \$3 35

DRAW AND COMPANY
Merchandise Jobbers

8 POINT

30 A 50a \$3 15

SEASIDE PROMENADE
Pleasant Moonlight Recreation
1234567890

6 POINT

30 A 50a \$2 75

NOTEWORTHY OCCURRENCES
Real Conflicts in the Warfare of Life
1234567890

EGYPTIAN EXTRA CONDENSED No 120

72 POINT

3 A 6 a 88 70

Anarchist WRESTLES

60 POINT

4 A 8 a 87 40

EUROPEANS Demonstrate

48 POINT

4 A 8 a 85 20

Graduating SCHOLARS Prompted

42 POINT

8 A 16 a 87 05

Auspiciously Decorated TURKISH BUILDINGS

36 POINT

8 A 16 a 85 25

GEOGRAPHICAL SURVEYOR Contemplates Disturbance

24 POINT

12 A 24 a 84 30

Newspaper Publishing Interesting FINANCIAL TELEGRAPHIC REPORTS

18 POINT

12 A 24 a 82 80

DETERMINED POLICEMEN

Caught Notorious Burglars Plundering

1234567890

12 POINT

16 A 32 a 82 60

EXHAUSTED SOLDIERS RETURN

Numerous Hardships are Encountered Abroad

1234567890

FRENCH CLARENDON No 120

72 POINT

3 A 5 a \$14 15

MINE Shaft

60 POINT

3 A 6 a \$8 50

Lead REGION

48 POINT

4 A 8 a \$6 80

INDIAN Prisoners

36 POINT

6 A 12 a \$6 50

BIG Horn

30 POINT

8 A 16 a \$4 65

Morning RUN

24 POINT

12 A 24 a \$4 55

**INDUCEMENTS
Landscape Garden**

18 POINT

12 A 24 a \$3 00

**CHINESE INCURSION
Dramatic Conformation**

12 POINT

18 A 36 a \$2 90

**CLEVER PERFORMERS
Good American Products**

10 POINT

24 A 48 a \$2 65

**EXPERIMENTAL MERCHANT
Manufacturers Easily Controlled**

8 POINT

24 A 48 a \$2 30

**NEBRASKA PUBLISHING COMPANY
Atlantic and Grand Rapids Railway
1234567890**

6 POINT

32 A 64 a \$2 10

**CURIOSITIES FROM NORTHWESTERN COUNTRIES
Young Maidens Escape From Seminary Boarding House
1234567890**

FRENCH CLARENDON EXTENDED No 120

42 POINT

3 A 5a \$8 85

FORTune

36 POINT

3 A 6a \$6 00

BENZINE
Ornamental

30 POINT

4 A 8a \$4 95

EXCURSION
Home Pledges

24 POINT

6 A 12a \$5 05

MINDS
Theaters

18 POINT

8 A 16a \$4 70

ROBBERS
Love Told

12 POINT

10 A 20a \$3 45

MUSICIAN
Establishing

11 POINT

12 A 24a \$3 50

DOMINIONS
Grand Rapids

10 POINT

16 A 32a \$3 45

HONEY MOONS
Spanish Gunboats

8 POINT

18 A 36a \$3 20

HUMANITY SAFE
Practically Established

6 POINT

18 A 36a \$2 30

PERMANENT WEATHER
Seeds of Gratitude and Loves
1234567890

5 POINT

20 A 40a \$2 85

MODERN DUTIES SUSTAINED
Late Hours and Daily Worrying
1234567890

FRENCH ANTIQUE No 110

48 POINT

3 A 4 a \$8 25

ERIE Lines

42 POINT

4 A 5 a \$8 20

Annual FAIR

30 POINT

6 A 8 a \$4 60

STORE
Good Wine

36 POINT

4 A 6 a \$5 60

MEN
Honored

20 POINT

10 A 16 a \$3 00

SELECTED
Illustrated Art

18 POINT

10 A 16 a \$2 75

ACTRESS
Great Performance

10 POINT

20 A 38 a \$2 50

IMPORTED WARES
Bohemian Enameled Glasses

12 POINT

20 A 38 a \$3 25

CHOICE BOOKS
Publisher of Literature

8 POINT

30 A 60 a \$2 70

HANDSOME LITHOGRAPH
Landscape, Portrait and Diploma
1234567890

6 POINT

30 A 60 a \$2 60

LITHOGRAPHING STONE
Favorite Shade where Girls Promenade
1234567890

DORIC No 120

48 POINT

3 A 8 a \$9 00

RICH Mine

42 POINT

3 A 8 a \$6 90

**FAST COLOR
Perfect Shade**

36 POINT

4 A 8 a \$6 40

**SNAKE
Oil Sold**

30 POINT

4 A 8 a \$5 40

**GAITER
Late Cut**

24 POINT

8 A 16 a \$5 50

**FLOWERS
Keep Sake**

18 POINT

10 A 20 a \$5 20

**NOBLEMAN
Prison Bird**

12 POINT

12 A 24 a \$2 90

**TIGER HUNTER
Fighting Elephant**

10 POINT

16 A 32 a \$2 95

**HONEST FARMER
Wearing Old Clothes**

8 POINT

20 A 40 a \$3 10

**KENTUCKY WHISKY
Excellent as Nose Paint**

7 POINT

24 A 48 a \$2 75

**BLACK EYES AND RED HAIR
Diamonds and Jewelry in Plenty**

6 POINT

24 A 48 a \$2 55

**GOVERNMENT MULE KICKED
For More Pay and Shorter Hours**

5 POINT ON 6 POINT

24 A 48 a \$2 55

**BLEAKEST SEASON ANNOUNCED
Cold Wintry Winds of December**

¼ X 1234567890 ¼ X

1234567890

ANTIQUE POINTED No 120

48 POINT

3 A 5a \$9 65

ONE Pint

42 POINT

3 A 6a \$7 45

Nice FACES

36 POINT

4 A 8a \$6 70

ROYAL Gown

30 POINT

5 A 10a \$4 50

**BEAUTIFUL BIRD
Historical Problems**

24 POINT

6 A 12a \$3 90

**SPECULATION RIFE
Wilder Market Rumor**

18 POINT

8 A 16a \$3 85

**WHIMPER
Heavy Stock
123456**

12 POINT

10 A 20a \$2 55

**JOINT FOUND
Destroying Life
1234567**

NEW TUSCAN No 120

48 POINT

4 A 8 a \$8 50

SPRING times

42 POINT

5 A 10 a \$6 80

HANnah

36 POINT

6 A 12 a \$6 05

Mad HOT

24 POINT

8 A 16 a \$4 00

Flower PIECE

18 POINT

10 A 20 a \$3 50

HOURLY Turning

CONCAVE No 120

36 POINT

4 A \$3 80

BASK

30 POINT

6 A \$3 50

MOIST

28 POINT

8 A \$3 55

MISERS

24 POINT

10 A \$3 30

FAT HOG

20 POINT

12 A \$2 95

CARDINAL

18 POINT

16 A \$2 65

DELIVERING

12 POINT

18 A \$1 65

ROW SPREADING

10 POINT

24 A \$1 50

REASON AND RHYME 57

8 POINT

24 A \$1 25

SHE WORE PURE DIAMONDS

6 POINT

32 A \$1 35

DANGEROUS BLACK BARBARIAN 23

CONCAVE CONDENSED No 120

72 POINT

4 A \$6 55

RUSH

60 POINT

5 A \$5 60

HOUSE

48 POINT

6 A \$4 80

MISTER

42 POINT

8 A \$3 85

WONDERS

36 POINT

10 A \$3 10

DISMOUNTS

20 POINT

18 A \$2 50

DENMARK SCENES

24 POINT

16 A \$2 60

SOUTHWESTER

16 POINT

24 A \$2 15

REMOVED SHERIFF 58

12 POINT

24 A \$1 20

FONDLY NEVER OF THEE 1549

CONCAVE EXTENDED No 120

36 POINT

4 A 8 a \$8 55

Shad

24 POINT

6 A 12 a \$5 75

Results

18 POINT

8 A 16 a \$4 55

BAD road

12 POINT

12 A 24 a \$3 25

Golden COINS

9 POINT

12 A 24 a \$2 35

FAVOR GRANTED
Trusting Agent 489

6 POINT

18 A 36 a \$2 25

EARNED HONEST MONEY
Driving Ducks to Water 1235

48 Point also furnished

EGYPTIAN EXTENDED

48 POINT No 20

3 A 5 a \$7 50

RICH India

36 POINT No 20

4 A 6 a \$5 50

**REAL HONEST
Establish Records**

24 POINT No 20

6 A 10 a \$4 25

**EARNEST SCHOLAR
Problems in Arithmetio**

18 POINT No 20

10 A 15 a \$3 50

**THE ROUND ROBINS NEST
Outside Secretarial Pigeonhole**

12 POINT No 20

14 A 20 a \$3 00

**HANDSOME SYNDICATE SALARIES
Paid for Closing Factory Twelve Years**

10 POINT No 30

20 A 30 a \$2 60

BLAND SMILE
Illuminated Cassius
12345678

8 POINT No 30

20 A 30 a \$2 60

THEATRE PARTIES
Luxuriant Entertainment
1234567890

LATIN EXTENDED

36 POINT

3 A 4a \$8 65

**NICE
Dinners**

30 POINT

4 A 6a \$6 90

**FRIED
Pheasant**

24 POINT

6 A 8a \$6 95

**GRAND
Corn Bread**

18 POINT

8 A 12a \$5 60

**HOT
Clams**

14 POINT

10 A 14a \$4 95

**CIDER
Oat Meal**

12 POINT

12 A 20a \$3 40

**POTATOES
Baked Onions**

10 POINT

18 A 24a \$3 60

**DUMPLINGS
Boiled Rock Fish**

8 POINT

24 A 32a \$3 75

**BEEFSTEAK
Biscuit and Pudding
1234567890**

6 POINT

30 A 40a \$3 90

**CAULIFLOWER
Cheese and Mild Coffee
1234567890**

MODERN ANTIQUE WIDE No 110

48 POINT

3 A 4 a 88 90

OLD Rites

36 POINT

4 A 6 a 87 00

Silver MINES

30 POINT

6 A 8 a 85 60

**SKETCHING
Ground Cinnamon**

20 POINT

10 A 16 a 84 85

**SELECTED DESIGN
Handsomest Adornments**

18 POINT

10 A 16 a 83 75

**CUMBERLAND RIVER
Pleasant Steamboat Excursion**

12 POINT

20 A 30 a 83 65

**DISTINGUISHED NEIGHBORS
North American Insurance Companies
1 2 3 4 5 6 7 8 9 0**

MODERN ANTIQUE

72 POINT

3 A 4 a \$11 20

MINER
Mountain

60 POINT

4 A 5 a \$10 25

RESORT
Convulsion

48 POINT

5 A 8 a \$10 00

MEETING
Administrator

MODERN ANTIQUE

42 POINT

6 A 10 a \$8 90

Patriotic LODGE

36 POINT

8 A 12 a \$8 50

**EMBROIDERY
Commission Brokers**

30 POINT

10 A 16 a \$6 40

**SECOND OUTING
Lake St. Clair Excursions**

20 POINT

12 A 20 a \$4 50

**COMBINED
Printers Album**

18 POINT

16 A 24 a \$3 90

**MEMORANDUM
Domestic Expenses**

12 POINT

20 A 40 a \$3 00

**MODERN PRINTING
Numerous Improvement**

10 POINT

24 A 50 a \$3 00

**ORNAMENTAL CARVING
Prize Compositions by Horn**

8 POINT

30 A 60 a \$3 00

**TRUMPET MANUFACTURER
Composer of Excellent Overture
1284567890**

6 POINT

30 A 60 a \$2 50

**NORTHERN LUMBER MERCHANT
Fine Pine Forest of Northern Michigan
1234567890**

LATIN CONDENSED No 150

72 POINT

4 A 6 a \$8 50

FURTIVE Fusiliers

60 POINT

5 A 6 a \$7 50

Evolution PLEASING

48 POINT

4 A 7 a \$5 50

DEMOLISHED Inclination

36 POINT

8 A 12 a \$4 25

PRACTICE
Skillful Person

30 POINT

10 A 15 a \$4 00

RECONCILED
Venturous Sailor

24 POINT

15 A 20 a \$3 75

BENEVOLENCE
Various Inconvenience

18 POINT

20 A 30 a \$3 25

REORGANIZATION
Defunct Building Associations

12 POINT

28 A 38 a \$3 00

BENEFICIAL PRESERVATION
Northern Peasants Build their Homes
1 2 3 4 5 6 7 8 9 0

10 POINT

36 A 50 a \$2 75

LAKE STEAMBOATS SPEEDING
Smooth Waters Allow Glorious Amusement
1 2 3 4 5 6 7 8 9 0

LATIN COMPRESSED No 30

48 POINT

6 A 10 a \$6 55

BLIND Horses

40 POINT

8 A 12 a \$5 75

REMONSTRATED
Political Orator

36 POINT

8 A 12 a \$4 45

SEVENTH EDITION
Railroad Quotation

24 POINT

10 A 15 a \$3 75

AMERICAN WEAPONS
National Introduction

18 POINT

15 A 20 a \$3 20

QUACK NOSTRUMS RELIEVE
Sensational Advertisements

12 POINT

20 A 30 a \$2 15

RELIABLE GOVERNMENT EMPLOYMENT
Internal Revenue Service Examination

1 2 3 4 5 6 7 8 9 0

O. S. LATIN CONDENSED

48 POINT

5 A 8 a \$4 85

RICH Miner

40 POINT

5 A 10 a \$4 15

HARMONIOUS
Peace Notices

36 POINT

8 A 12 a \$3 80

MODERN RANCH
Cuban Horsemen

24 POINT

12 A 20 a \$3 65

ALASKAN DIAMOND
Yukon River Hunter

18 POINT

20 A 30 a \$3 40

INDUSTRIAL SECURITIES
Columbus Machine Exhibit

12 POINT

25 A 40 a \$2 45

TENDEREST MEMORIES SILENCED
Ocular Institute for Blinded Lover

1 2 3 4 5 6 7 8 9 0

LATIN ANTIQUE No 120

48 POINT

3 A 5 a \$7 70

China BIRD

36 POINT

4 A 8 a \$5 90

MILK Crackers

30 POINT

6 A 12 a \$5 35

Household WORDS

24 POINT

8 A 16 a \$4 50

ROBUST MAIDEN
Regular Business Gowns

18 POINT

10 A 20 a \$3 65

GARDEN
Rustic Baskets

12 POINT

12 A 24 a \$2 45

BURDENSOME
Weighing Machines

10 POINT

18 A 36 a \$2 95

HAYSEEDERS
Untutored Dunderpates

8 POINT

24 A 48 a \$3 00

WINTER STORMS
Sweeping Hurricane Decks

6 POINT

24 A 48 a \$2 60

IMPECUNIOSITY
Decidedly Small Bank Accounts
1 2 3 4 5 6 7 8 9 0

5 POINT ON 6 POINT

24 A 48 a \$2 15

HARMONIOUS GATHERING
Conducted Without Pomp or Ceremony
1 2 3 4 5 6 7 8 9 0

LIGHT RUNIC SERIES

----- 0-15 -----

60 POINT NO 110

4 A 6 a \$9 35

TIME Records

42 POINT NO 152

5 A 8 a \$7 25

Mansion HOUSE

36 POINT NO 110

5 A 8 a \$6 85

RUINED Landlord

30 POINT NO 152

8 A 12 a \$5 95

Magnificent LOUNGES

24 POINT NO 152

10 A 16 a \$4 55

INDUSTRIAL Organizations

18 POINT NO 152

12 A 18 a \$3 30

MEETINGS
Religious Service

14 POINT NO 152

14 A 20 a \$2 40

ENTERPRISING
Business Undertakings

12 POINT NO 152

20 A 40 a \$2 80

NATIONS CONSULTING
Peace With the United States
1234567890

10 POINT NO 152

18 A 36 a \$2 00

POLITICAL CONVENTION
Discussing Good Solid Government
1234567890

RUNIC CONDENSED No 120

72 POINT

3 A 5 a \$12 85

DOG Hunt

60 POINT

3 A 5 a \$8 25

Roman GOLD

48 POINT

3 A 6 a \$6 10

UNITED Soldiers

42 POINT

4 A 8 a \$4 60

Builders STEAMSHIP

30 POINT

5 A 10 a \$3 40

HIGH Grade

24 POINT

6 A 12 a \$2 80

LUMBER Yard

18 POINT

8 A 16 a \$2 60

GOLD STANDARD
United Americans

14 POINT

10 A 20 a \$2 05

SUBMARINE TORPEDO
Long Distance Runners

12 POINT

12 A 24 a \$1 80

MACHINERY IMPROVEMENT
Independence Declarations
1234567890

10 POINT

18 A 36 a \$1 95

CONGRESSIONAL COMMITTEEMEN
Twelfth and Seventeenth Districts
1234567890

RUNIC CONDENSED No 122

60 POINT

4 A \$6 55

RESORTS

48 POINT

4 A \$4 05

FAITH CURE

42 POINT

6 A \$4 05

ASTRONOMICAL

36 POINT

8 A \$3 15

MINERAL DEPOSITS

24 POINT

10 A \$2 40

ORNAMENT

20 POINT

12 A \$2 10

CELEBRATION

16 POINT

16 A \$1 75

EVENING GOWNS

12 POINT

18 A \$1 35

NEVER EXPECT MUCH

10 POINT

24 A \$1 30

CALIFORNIA TALL FORESTS
1234567890

8 POINT

32 A \$1 40

BROUGHT SUFFICIENT REWARDS
1234567890

LIGHTFACE CELTIC No 150

48 POINT

3 A 4 a \$8 50

THE Pink

36 POINT

4 A 6 a \$6 25

Hound NETS

30 POINT

5 A 7 a \$5 00

LENDs Machines

24 POINT

7 A 10 a \$3 50

ENTERPRISE
Making Ocean Breezes

18 POINT

10 A 16 a \$3 25

RECONSTRUCTION
Fuglemen Swearing Allegiance

12 POINT

16 A 26 a \$3 00

AGONIZING
Felines Nightly Song

10 POINT

18 A 28 a \$2 75

INDIFFERENCE
Unconcerned Spectators

8 POINT

20 A 30 a \$2 50

MODERN KNIGHTS
Heart of Tender Sensibility
1234567890

6 POINT

22 A 32 a \$2 25

EUREKA RESTAURANT
Gutta Percha Beef and Ram Chops
1234567890

CELTIC No 3 SERIES

24 POINT

8 A 8 A 10 a 86 70

PROMINENCE
Great Natural Lakes
RUSTIC HOMES

18 POINT

10 A 10 A 15 a 85 45

SUMMER TOURIST
Reliable Pacific Steamer
PLEASURE TRIPS

12 POINT

14 A 14 A 20 a 84 30

SOUTHERN EXPOSITION
Grand Cotton Plantation Exhibits
INDUSTRIAL RESOURCES

10 POINT

18 A 18 A 30 a 84 10

RICH COSTUME
Dramatical Combine
GRAND OPERA

8 POINT

20 A 20 A 40 a 83 85

HOME PRODUCT
American Iron Dealers
MINING REGIONS

7 POINT

20 A 20 A 40 a 83 00

LONDON INSURANCE
All Losses and Damages Paid
123 RELIABLE 678

6 POINT

35 A 30 A 40 a 83 90

LATEST IMPROVED MACHINE
Patented Brass Rule Mitring Machine
12345 ORNAMENTS 67890

ROMANESQUE SERIES

30 POINT NO 150

5 A 5 A 85 10

CLEVER GENIUS

24 POINT NO 150

6 A 6 A 84 00

TIN CANS

18 POINT NO 150

10 A 10 A 83 50

SPAN INSIDE

12 POINT NO 150

14 A 14 A 83 00

ALMOST PRECISE

10 POINT NO 150

16 A 16 A 82 50

HARBOR IN AUTUMN

8 POINT NO 150

18 A 18 A 82 00

FASTENED OLD SPRING

6 POINT NO 151

20 A 20 A 82 25

PEDESTRIAN TAKEN PRISONER

6 POINT NO 152

20 A 20 A 82 25

RESERVED MEN OF STRONG CHARACTER
1 2 3 4 5 6 7 8 9 0

6 POINT NO 153

20 A 20 A 82 25

DULL CHRISTMAS SPORTS WITHOUT FROST AND SNOW
1 2 3 4 5 6 7 8 9 0

NORMAN CONDENSED

36 POINT

5 A 6 A 84 50

SEASIDE PROMENADE

24 POINT

5 A 8 A 83 83

HUNTER
MEAN BEARS

18 POINT

10 A 16 A 83 15

PHANTOMS
GHOST APPARITIONS

12 POINT

20 A 32 A 82 95

OFFICIAL BUSINESS
MUNICIPAL INDEBTEDNESS
1234567890

10 POINT

20 A 32 A 82 93

CHRISTMAS THOUGHTS
FAIR WONDERLAND PANORAMA
1234567890

LIGHTFACE CELTIC CONDENSED No 120

36 POINT

6 A \$2 15 6 A 6 A \$3 90

REMARKABLE PERFORMERS

32 POINT

8 A \$2 10 8 A 8 A \$3 70

NORTHWESTERN MANUFACTURES

30 POINT

10 A \$1 90 10 A 10 A \$3 45

VICTORIOUS TARS HOMEWARD BOUND

24 POINT

12 A \$1 75 12 A 12 A \$3 15

HOUSEHOLD COMFORTS FOR EVERYBODY
ROYAL RECEPTION FOR RETURNING SOLDIERS

20 POINT

16 A \$1 85 16 A 16 A \$3 20

HUMOROUS TEACHER
FRATERNAL INCLINATIONS

18 POINT

18 A \$1 40 18 A 18 A \$2 50

INTERESTED IN HORSEMEN
AMERICAN MEDICAL GATHERING

12 POINT

24 A \$1 10 24 A 24 A \$2 05

COMMISSIONERS EXAMINATIONS
LAND OF THE FREE AND THE BRAVE

10 POINT

32 A \$1 35 32 A 32 A \$2 45

HOME COMING OF CUBAN SOLDIERS
CROWNED WITH LAURELS OF VICTORY

8 POINT

36 A \$1 25 36 A 36 A \$2 15

GRAND REVOLUTIONARY REMINISCENCES
MINNESOTA FARMERS MACHINE SUPPLY HOUSE

6 POINT No 122

48 A \$1 30

SLENDERLY SHAPED SAILORMEN FEVER FAINTING
KLONDIKE NUGGETS ARE VERY POPULAR 12346578

COMBINATION GOTHIC

12 POINT No 159

16 A \$1 50

MAGNIFICENT SACRED PANORAMIC EXHIBITS

12 POINT No 158

16 A \$1 50

BARNSTORMING
BREAKING CONTRACT

12 POINT No 157

18 A \$1 25

ORDERING WARSHIPS
STRONG VETERANS MARCH

12 POINT No 156

24 A \$1 25

MERCHANTS COMPLAIN
BANKING FAILURES REPORTED

6 POINT No 155

32 A \$1 50

TROUBLESOME MACHINERY
MECHANICAL DISCOVERY DOUBTED

6 POINT No 154

42 A \$1 50

UNVEILING FRANKLIN STATUE
THOUSANDS ATTEND THE OPENING SERVICE

6 POINT No 153

42 A \$1 50

WEALTHIEST AMERICAN ENTERPRISE
EXPORTING VARIOUS ARTICLES MANUFACTURED

6 POINT No 152

50 A \$1 25

WONDERFUL AUSTRALIAN ACROBATIC PERFORMER
ASTONISHING FEAT BROUGHT FORTH THUNDERING APPLAUSE

1 2 3 4 5 6 7 8 9 0

5 POINT No 151

55 A \$1 25

GERMAN SINGING VEREINS ENJOYING DRAMAS
OKLAHOMA COWBOY DESPERADO RELIEVING NUMEROUS PASSENGERS

1 2 3 4 5 6 7 8 9 0

COMBINATION CONDENSED GOTHIC

12 POINT No 166

16 A \$1 50

RESIDENTS ANTICIPATING THE FORMATION OF YACHTING ORGANIZATIONS

12 POINT No 165

18 A \$1 25

SERENADERS WERE GATHERING NEAR THE HOUSE WHEN THE COLONELS RESPOND

12 POINT No 164

24 A \$1 25

LECTURING UNDER DIFFICULTIES
SPEAKERS HOARSE AND AUDIENCE FROZEN

6 POINT No 163

32 A \$1 50

COURAGEOUS COMPOSITOR TRAMPERS
SEVERAL DELIGHTFUL MEDICAL DISCOVERIES PERFORMED

6 POINT No 162

40 A \$1 25

SCHEDULED RAILROAD TRAINS WRECKED
DELAYING FOREIGN FREIGHT NEARLY TWELVE MONTHS

1 2 3 4 5 6 7 8 9 0

6 POINT No 161

50 A \$1 25

MOUNTAIN CLIMBING GREATLY ENJOYED
SOUTHERN CLIMATE SOUGHT DURING SEVERE COLD WEATHER

1 2 3 4 5 6 7 8 9 0

GOTHIC CONDENSED No 112

24 POINT

12 A 20 a \$3 75

BROTHER DANCES Blackface Specialties

18 POINT

16 A 24 a \$3 20

Unexpected Combination BROUGHT BRACKETS

12 POINT

24 A 36 a \$3 08

BREAKERS LOWERING WHALING CREWS
Thornton Anniversary Receptions and Operatic Entertainments

10 POINT

28 A 44 a \$2 50

SHOPLIFTER SELECTING
Watches and Precious Stones Taken
1234567890

8 POINT

40 A 62 a \$2 70

RENOWNED LITERARY PERSON
Prominent Writers Hesitate Sending Articles
Dreading Instantaneous Remittances
1234567890

JOHNSON GOTHIC

16 POINT

16 A 24 a \$4 00

GENTEEL MEN ESTABLISHED
Automatic Millionaire Purchasing Securities

14 POINT

14 A 36 a \$3 75

STIRRING POLITICAL SPEECHES
Wonderous Adventures in King Solomon's Mines

12 POINT

15 A 40 a \$3 50

SERIES FURNISHED
Cheaper Refreshment Ticket

10 POINT

18 A 45 a \$3 00

MAGNIFICENT YACHT
Trained Animals for Performances

8 POINT

20 A 50 a \$2 50

NUMEROUS REQUESTS
Beautiful Productions from Flowers
1234567890

6 POINT

24 A 60 a \$2 25

COMMERCIAL ADVERTISER
Unavoidable and Laughable Adventures
1234567890

COMBINATION GOTHIC

24 POINT NO 1528 8 A \$3 00

BADGES

18 POINT NO 1526 12 A \$2 50

SHOUTING

12 POINT NO 1524 20 A \$2 25

REFRESHMENT

12 POINT NO 1522 24 A \$2 25

JUBILANT SOLDIERS

6 POINT NO 1533 40 A \$2 00

CROWDED RAILROAD TRAINS

6 POINT NO 1531 42 A \$1 60

INDUSTRIAL ESTABLISHMENTS CLOSED

6 POINT NO 1529

12348 MAGNIFICENT SHOWING OF THE REGULAR TROOPS 67880

24 POINT NO 1527

8 A \$3 00

TRIUMPH

18 POINT NO 1525

14 A \$2 40

CONDUCTORS

12 POINT NO 1523

24 A \$2 25

MILITARY PARADES

12 POINT NO 1521

30 A \$2 25

PUBLIC ENTERTAINMENT

6 POINT NO 1532

40 A \$1 75

DISTINGUISHED GUARDS IN LINE

6 POINT NO 1530

45 A \$1 50

HEROES OF NUMEROUS FIERCE ENGAGEMENTS

45 A \$1 40

TELESCOPIC GOTHIC

6 POINT NO 158 30 A \$2 00

PUNISHMENT FOR CRIMINALS

6 POINT NO 156 30 A \$1 15

LENIENT JUDGE RELEASED THE PRISONER 218

6 POINT NO 157

30 A \$1 60

HABEAS CORPUS PROCEEDING BEGAN

6 POINT NO 155

30 A \$1 00

GREAT INTEREST MANIFESTED BY PRETTY SPECTATORS 456

IMPRINT GOTHIC

6 POINT NO 121 32 A \$0 75

IRATE HUSBANDS DENOUNCE THE PROPOSED FEMALE SUFFRAGE

6 POINT NO 124

12345 DEMANDING THE RIGHT OF CARRYING LATCH KEYS IN DAY TIME 67890

6 POINT NO 150

48 A \$0 75

STRONG RESOLUTIONS UNANIMOUSLY ADOPTED AT THE WENPCKE ASSOCIATION MEETING

28 A \$0 65

COPPER ALLOY IMPRINTS

Cast in one piece, any of the faces here shown, at the following prices:

* 100 OF ANY ONE KIND FOR \$8 00 NET.

50 OF ANY ONE KIND FOR \$5 00 NET.

STYLE 1
EXCELSIOR PRINTING CO., DENVER

STYLE 4
FITLER JOB PRINTING COMPANY

STYLE 6
LEDGER PRINT, FRANKLIN

STYLE 2
PRESS OF STYLES & CASH, NEW LONDON

STYLE 5
STANDARD PRINTING & BINDING CO., CHICAGO

STYLE 7
SUNSHINE PUBLISHING HOUSE, CANTON

STYLE 3
NEVER-SLEEP BOOK AND JOB PRINTING CO., WAKEFORD, OHIO

STYLE 8
DIXON, PRINTER AND STATIONER

* If Imprints are wanted longer than one and one-fourth inches in length, they will have to be made in two or more pieces, and \$3.00 extra per hundred will be charged for each extra piece.

GOTHIC No 127

42 POINT

4 A \$3 40

CANARY BIRD

36 POINT

5 A \$2 70

GREAT STORMS

30 POINT

6 A \$2 40

PLEASANT MAIDEN

24 POINT

8 A \$2 25

GROWING REVENUES

20 POINT

10 A \$2 30

CUSTOMER

18 POINT

12 A \$2 00

OCEAN TRIPS

18 POINT

16 A \$2 05

FRESH LIQUOR

12 POINT

18 A \$1 80

TICKET SCALPER

10 POINT

24 A \$1 80

EVENING GREETING
STATIONERY FIRMS

8 POINT

32 A \$1 90

EVANGELICAL MINISTERS
FRICASSEE OF CHICKEN

6 POINT

36 A \$1 60

CONSTRUCT DESIRED BRIDGES
BY THE SEASHORE COURTED

5 POINT ON 6 POINT

36 A \$1 30

FIRST ILLINOIS REGIMENT RECEPTION
RETURN FROM SANTIAGO BATTLEFIELD

4 1/2 POINT ON 6 POINT

42 A \$1 25

HANDSOME AND SERVICEABLE FARM MACHINERY
MINNESOTA AND WISCONSIN FARMING PRODUCTS

3 POINT ON 6 POINT

48 A \$1 10

MATRIMONIAL VOWS AND ADVENT OF THE FIRST-BORN CHILD
INDUSTRIAL DEPARTMENT EMPLOYING BRAINS AND MUSCLES

1254567890

1234567890

INTERCHANGEABLE GOTHIC

48 POINT

3 A \$5 90

MINORS

36 POINT

4 A \$3 90

CONJURED

32 POINT

4 A \$3 00

HARBORING

24 POINT

6 A \$2 45

UNITED MARINE

20 POINT

8 A \$2 50

GROUND

18 POINT

12 A \$2 30

MONITORS

12 POINT

18 A \$2 00

BATTLE FIELDS

10 POINT

18 A \$1 35

COLD ATMOSPHERE

8 POINT

24 A \$1 35

REMEMBER OUR HEROES
SOLDIERS COMING HOME

6 POINT No 5

36 A \$1 70

IMMENSE FARM PROPERTIES
GOOD NEWSPAPER REPORTS

6 POINT No 4

36 A \$1 45

EMBRACES OF AFRICAN GORILLAS
ARE STRUGGLING AGAINST POWER

6 POINT No 3

36 A \$1 25

BREAKFAST TIME AMONG INSURGENTS
HORRORS DURING FRENCH REVOLUTION

6 POINT No 2

36 A \$1 05

YELLOWSTONE GEYSER WATER CORPORATION
ANGRY HOUSEWIVES OVERHAULING BUREAUS
1234567890

6 POINT No 1

36 A \$0 90

INTERNATIONAL CONGRESS ON FUTURE WARFARE
NOT TO EXCEED OVER ONE HUNDRED THOUSAND MEN
1234567890

5 sizes on 6-Point body, \$6.00

All sizes line at the bottom. 12 to 48 Point line at both top and bottom

Complete series, 14 sizes, \$70.00

GOTHIC No 49

72 POINT

4 A \$10 90

OFFICE

48 POINT

5 A \$7 20

MIDNIGHT

GOTHIC No 1510

30 POINT

10 A \$4 50

HOUND BARKING

24 POINT

12 A \$3 20

PROWLERS CAPTURED

20 POINT

14 A \$2 80

REWARD VIGILANT GUARD

16 POINT

16 A \$2 50

SOUND WORDS

14 POINT

18 A \$2 25

BARGAIN CORNER

12 POINT

22 A \$2 00

AMOUNTS CERTIFIED

10 POINT

24 A \$1 75

HEAVY WINTER CLOTHING

8 POINT

28 A \$1 35

WORSHIPING FAMOUS LECTURERS

6 POINT

36 A \$1 25

HISTORIC MOUNTAIN RESORT WAS CROWDED

1 2 3 4 5 6 7 8 9 0

1 2 3 4 5 6 7 8 9 0

GOTHIC CONDENSED No 127

48 POINT

4 A \$3 00

MADISON RECORDER

42 POINT

5 A \$2 40

HUNTERS 56 MOUNTED

36 POINT

8 A \$2 45

DENVERS SQUARE GARDENS

30 POINT

10 A \$2 30

MATHEMATICS

24 POINT

12 A \$2 15

DEMONSTRATIVE

20 POINT

16 A \$2 10

DENTAL 45 PARLOR

18 POINT

18 A \$1 90

HUMANE 68 BELOVED

16 POINT

24 A \$1 95

POPULATION INCREASING

12 POINT

32 A \$1 80

BEAUTIFUL FLOWER GARDENS

10 POINT

36 A \$1 40

NUMEROUS EXPERIENCED TRADESMEN
REPORTED 546 SWINDLED

8 POINT

42 A \$1 35

BRIBERY CHARGES CONCERNING PROMINENT
GOVERNMENT 45678 OFFICIALS

6 POINT

48 A \$1 25

KNOWING THAT THE HUMAN HAND IF INTELLIGENTLY
EDUCATED AND SKILLFULLY EMPLOYED

5 POINT ON 6 POINT

56 A \$1 30

THIS INTELLIGENT COMBINATION OF RECENT IMPROVEMENTS
PRESENTED FOR FURTHER CONSIDERATION

GOTHIC CONDENSED No 128

48 POINT

4 A \$3 55

GOOD PROPERTY

42 POINT

5 A \$2 80

HUNTER MOUNTED

36 POINT

8 A \$3 10

REWARDING SOLDIERS

30 POINT

10 A \$2 65

POPULATION

24 POINT

12 A \$2 25

HUMAN HANDS

20 POINT

16 A \$2 45

DENTAL PARLOR

18 POINT

18 A \$2 10

MIDNIGHT VISITORS

16 POINT

24 A \$2 10

INDEPENDENT FARMER

12 POINT

32 A \$2 10

PRETTY MAIDEN SMILES

10 POINT

36 A \$1 70

MANUFACTURING NEAT BORDER

8 POINT

42 A \$1 65

SEVERAL EXPERIENCED TRADESMEN

6 POINT

48 A \$1 55

PRESENTED FOR IMMEDIATE CONSIDERATION

5 POINT ON 6 POINT

56 A \$1 45

YOUNG CHILDREN ADMITTED TO AFTERNOON SCHOOLS

1234567890

CHAMFER CONDENSED

96 POINT

5 A \$12 80

ENCOURAGED

84 POINT

5 A \$10 30

SHIPWRECKED

72 POINT

7 A \$9 90

RECENT DECISION

60 POINT

7 A \$7 15

CAVALIER ADVANCED

48 POINT

7 A \$6 15

40 POINT

10 A \$4 90

PROMOTER PRESUMPTIVE

CHAMFER CONDENSED

36 POINT 10 A \$3 75

GARDEN HOMES

22 POINT 18 A \$3 00

REMEDIES FOR CHOLERA

12 POINT 36 A \$2 60

CAREFUL HABITS AND GOOD INTENTION

8 POINT 45 A \$2 00

WESTERN HEMISPHERE EXPLORED BY NOTED STUDENTS
1234567890

28 POINT 14 A \$4 00

THREE PRECINCTS

18 POINT 30 A \$3 60

BARGAIN SALE OF FINE CHINA

10 POINT 36 A \$2 00

HEROIC SACRIFICES MADE BY A YOUNG WOMAN

6 POINT 52 A \$2 00

HANDSOME ENGRAVINGS DRAWN BY SOME OF THE LEADING ARTISTS
1234567890

GOthic EXTRA CONDENSED No 150

48 POINT

5 A 8a \$5 00

RENUMBERED Antiquated Houses

40 POINT

6 A 9a \$4 50

Musicians Gave NOVEL EXHIBITION

30 POINT

10 A 16a \$4 50

DEMAND Satisfaction

24 POINT

12 A 18a \$3 50

RENOMINATE County Clerk

18 POINT

18 A 24a \$3 25

Contest of Noted STRONG MEN

12 POINT

20 A 40a \$3 00

Election Returns Read FROM THE STAGE

10 POINT

20 A 38a \$2 75

ADVANCE GUARD MEETS With Some Resistance
1234567890

8 POINT

22 A 32a \$2 50

PROMINENT MERCHANTS Arranging Monthly Expositions
1234567890

GOTHIC EXTRA CONDENSED No 122

72 POINT

4 A 8 a \$10 75

MINERS Grievances

60 POINT

5 A 10 a \$9 65

Undismayed FREEMEN

48 POINT

6 A 12 a \$9 20

SPAIN Cuba

42 POINT

6 A 12 a \$8 90

INDIAN Blanket

36 POINT

6 A 12 a \$4 80

AMERICAN VICTOR
Properly Celebrated

30 POINT

8 A 16 a \$4 80

RENOWNED METEOR
Elaborately Displayed

24 POINT

10 A 20 a \$4 20

INCREASED POPULATION
Black Fighters of the Congo

22 POINT

12 A 24 a \$4 00

CONGRESSIONAL ELECTORATE
Having Four Revolving Wheels

18 POINT

16 A 32 a \$3 80

PROCURING CELEBRATED MEDICINES
Outlaws Chasing the Kings Red Deer
1234567890

12 POINT

18 A 36 a \$2 35

CHARITABLE LADIES DISTRIBUTING OLD CLOTHING
MICROSCOPIC INDICATIONS
Revised History of Many Celebrated Modern Characters
1234567890

GOTHIC CONDENSED No 124

48 POINT

4 A 8 a 86 40

Tortures ENDURED

42 POINT

4 A 8 a 85 05

SURGICAL Instruments

36 POINT

6 A 12 a 85 50

MAGNIFICENT PRODUCTION
Commendable Newspapers

30 POINT

8 A 16 a 84 35

UNPRECEDENTED ATTRACTION
Thirteenth Industrial Exposition

24 POINT

12 A 24 a 84 45

INDESTRUCTIBLE
Coast Fortification

18 POINT

12 A 24 a 83 05

FASHIONABLE MAID
Modest and Beautiful

12 POINT

18 A 36 a 82 65

REQUIRED SATISFACTION
Standard Schemes Adopted

10 POINT

24 A 48 a 82 65

RECEIVING VISITING KNIGHTS
Chicagoan Unprecedented Growth

8 POINT

32 A 64 a 82 85

UNRIVALED BICYCLE MANUFACTURE
Eighty-Seven Thousand Dollars Required
1234567890

6 POINT

32 A 64 a 82 30

CONFESSED MURDERER ADMITTING CRIMES
Very Extensive Southern Australia Diamond Fields
American Type Founders Company
1234567890

GOTHIC CONDENSED No 123

36 POINT

6 A 12 a 85 90

HANDSOME BUILDINGS
Credit Renowned Architect

30 POINT

10 A 20 a 84 90

DIAMOND COMBINE EXPOSED
Australian Mines Seem to Prosper

24 POINT

12 A 24 a 84 00

FARM MACHINERY IN GREAT DEMAND
For Cuba Porto Rico Manila and Honolulu

18 POINT

12 A 24 a 82 95

EVENING ROAMINGS
Will Conduce Slumber

14 POINT

18 A 36 a 83 15

STRONG WINTER GALES
Decks Swept by Hurricane

12 POINT

18 A 36 a 82 55

INTERNATIONAL MUSEUMS
Travelers Compliment Them
See That They Are Plentiful
1234567890

10 POINT

24 A 48 a 82 55

SHARPSHOOTERS TOURNAMENT
Professional Marksmen Are Adepts
Autumn Brings Sport to the Hunter
1234567890

8 POINT

32 A 64 a 82 80

BELEAGUERED WAYFARERS DESTITUTE
Discomforts of Sojourning in Darkest Africa
Thrilling Experience of Seven Englishmen
The Upper Congo is a Terror to White Men
Everything Succumbs Under Tropical Heat
1234567890

6 POINT

32 A 64 a 82 35

ROMANTIC MOUNTAIN AND VALLEY SCENERY
Amateur Athletes Climbing Aloft to the Pinnacle
Sunshine Carries Happiness to the Woodsman
Bland Nature Smiles on Winding Forest Streams
Cloudbursts Are Frequent in all Lofty Locations
1234567890

GOTHIC CONDENSED No 122

72 POINT

3 A \$4 25 3 A 6 a \$10 85

RIFLE TO Send

60 POINT

3 A \$2 90 3 A 6 a \$7 70

Silver BOX TRADE

48 POINT

5 A \$2 65 4 A 8 a \$6 10

BIG House

42 POINT

5 A \$2 05 6 A 12 a \$5 90

HARD Bread

36 POINT

5 A \$1 45 8 A 16 a \$6 40

PURE MAIDS
GOLDEN Ideas

24 POINT

6 A \$1 05 10 A 20 a \$3 85

REFORM POLICE
EXCURSION Rates

20 POINT

8 A \$1 00 10 A 20 a \$3 10

DUTCH NAVIGATOR
PENSION Directories

18 POINT

8 A \$0 70 12 A 24 a \$2 80

HOMeward JOURNEY
SOLDIERS Lead Patriotic

12 POINT

10 A \$0 50 18 A 36 a \$2 30

ENGLISH OPERA PERFORMER
INHABITANT OF NEWFOUNDLAND
When the Sparrows Homeward

10 POINT

20 A 40 a \$1 75

OBSERVE THE CYCLONE WHIRLWIND
Christmas Games and Well-Filled Larder
Toothsome Delicacies Devoured 234567

Small Caps not sent unless expressly ordered

GOTHIC CONDENSED No 129

* 72 POINT

12-16

4 A 6 a \$11 80

HONEST Bears

* 60 POINT

4 A 6 a \$8 50

Favors DIAMOND

48 POINT

6 A 10 a \$6 35

GOLD Fish

42 POINT

10 A 12 a \$5 90

Good HORSE

36 POINT

10 A 12 a \$4 60

**HOUSEHOLDS
Copper Button**

24 POINT

15 A 20 a \$4 00

**ILLINOIS MINERS
Traveling Tourists**

20 POINT

15 A 20 a \$2 65

**GRAND MASQUERADE
Moonlight Promenading**

18 POINT

15 A 25 a \$2 10

**MECHANICAL DECORATION
Combinations of Machinery**

12 POINT

20 A 30 a \$1 85

**FINE MODERN FRESCO PAINTINGS
Regular Excursion to South Africa
1234567890**

* 10 POINT

20 A 40 a \$1 75

**GOVERNMENT TELEGRAPH OWNERSHIP
Dark Inhabitants of Southern Plantations
1234567890**

GOTHIC CONDENSED No 37

72 POINT

4 A \$8 20 4 A 6 a \$14 15

MEN Count

60 POINT

5 A \$6 50 5 A 6 a \$10 80

Rulers HUNT

48 POINT

6 A \$5 55 6 A 10 a \$9 75

BIG Job

40 POINT

6 A \$4 00 6 A 10 a \$6 90

HO Heme

36 POINT

8 A \$3 75 8 A 12 a \$6 55

**TOSSED
White Seas**

28 POINT

10 A \$2 95 10 A 15 a \$5 35

**WRECKED
Sunk or Lost**

22 POINT

12 A \$2 50 12 A 8 A 20 a \$5 35

**IMPRISONED
BURNT Demented**

18 POINT

15 A \$1 95 15 A 10A 25 a \$4 20

**APPROPRIATION
INTRODUCES Disasters**

12 POINT

20 A \$1 40 20 A 12 A 30 a \$3 00

**DESPERATE UNREST
DEVITALIZES Developments
1234567890**

10 POINT

25 A \$1 35 25 A 20 A 40 a \$3 15

**UNCONSIDERED ASSERTIONS
VOLUNTEERED Without Conditions
1234567890**

MID-GOTHIC SERIES

72 POINT

3 A 4 a \$14 00

LOST Run

60 POINT

3 A 4 a \$10 00

Hand GONE

54 POINT

3 A 5 a \$8 00

FRIGID Blast

48 POINT

4 A 6 a \$7 25

**CHAMPIONS
Undiscouraged**

42 POINT

5 A 8 a \$6 50

**DELIGHTFUL
Mountain Resorts**

MID-GOTHIC SERIES

36 POINT

6 A 9 a \$5 00

**LAUDABLE ACT
Saved Drowning Man**

30 POINT

7 A 10 a \$4 25

**CALIFORNIAN MINERS
Expect Fabulous Returns**

24 POINT

9 A 12 a \$4 00

**DESERVED PUNISHMENT
Overtakes Audacious Lynchers**

18 POINT

12 A 16 a \$3 50

**MISREPRESENTED CONSTITUENTS
Popular Sentiment Favors Investigation**

14 POINT

12 A 18 a \$3 25

**AMUSEMENT FROM ELECTRICAL DEVICES
Latest Juvenile Toys Unite Science with Pleasure**

12 POINT

16 A 20 a \$3 00

**WESTERN METROPOLIS
Honors Returning Delegation**

10 POINT

20 A 26 a \$2 75

**MAGNIFICENT GATHERINGS
Celebrated Etymological Authorities**

8 POINT

22 A 30 a \$2 50

**JOYOUS CHRISTMAS HOLIDAYS
Extensive Arrangements for Good Children
1234567690**

6 POINT

24 A 36 a \$2 25

**RARE BARGAINS IN ANTIQUE FURNITURE
Large Collections of Imported Tables and Wardrobes
1234567890**

ROYAL GOTHIC

48 POINT

4 A 8 a \$8 95

LIGHT Return

36 POINT

5 A 10 a \$7 05

Meteor SECOND

30 POINT

6 A 12 a \$5 25

**EXCURSION NORTH
Round Trip Tickets**

24 POINT

8 A 16 a \$5 05

**BOHEMIAN RETURNED
Resignations Tendered**

20 POINT

10 A 20 a \$4 80

**CHRISTMAS
Santa Claus**

18 POINT

10 A 20 a \$3 15

**GREAT POLICE
Serving County**

12 POINT

16 A 32 a \$3 15

**MODERN RAILROAD
Splendid For Travel**

10 POINT

18 A 36 a \$2 70

**DISPOSING OF STOCKS
Big Inducement Offered**

8 POINT

24 A 48 a \$3 05

**FIRST DIVIDEND RECEIVED
Money Used for Church Debt
1234567890**

6 POINT

24 A 48 a \$2 25

**BRIGHT AMERICAN COMEDIANS
Relating Their Exotting Adventures
1234567890**

GOTHIC No 122

48 POINT

5 A \$5 45 3 A 6 a \$9 25

HOME Ties

42 POINT

4 A \$3 40 4 A 8 a \$8 00

Clam BAKES

36 POINT

5 A \$3 10 4 A 8 a \$6 60

HORSE Taming

30 POINT

6 A \$2 55 5 A 10 a \$5 35

ARE Nearer HOME

24 POINT

8 A \$1 85 8 A 16 a \$5 35

**HUMORS
BAD Paste**

20 POINT

10 A \$1 70 10 A 20 a \$4 90

**CONQUERS
SURE Winner**

18 POINT

10 A \$1 25 10 A 20 a \$3 15

**ARTIST PAINT
NATURE Fresh**

12 POINT

16 A \$1 20 16 A 32 a \$3 65

**GOLD HUNTING
KLONDIKE Mining**

10 POINT

18 A \$1 15 18 A 36 a \$3 15

**HOLIDAY PRESENT
Countersigned NOTES**

8 POINT

24 A \$1 10 24 A 48 a \$3 45

**WONDERFUL MACHINE
FLYING Through the Skies**

6 POINT

24 A \$0 90 24 A 48 a \$2 65

**PREACH TOUCHING SERMONS
Congregation Praise DISCOURSE
1234567890**

5 POINT

24 A 48 a \$2 90

**PATENT CYLINDER PRINTING PRESS
Most Beautiful, Glorious and Charming
1234567890**

Small Caps with all sizes except 5 Point. Small Caps not sent unless expressly ordered

GOTHIC No 125

48 POINT

4 A 8 a \$9 30

HORSE brain

42 POINT

4 A 8 a \$7 10

Railroad UNION

36 POINT

6 A 12 a \$7 10

**UNITED POWERS
Adopt Golden Rule**

30 POINT

8 A 16 a \$5 20

**INDUSTRY
Heavy Purse**

24 POINT

10 A 20 a \$4 35

**SILVER MINE
Fine Diamonds**

18 POINT

12 A 24 a \$3 80

**SPANISH MAKE
Cuban Departing**

14 POINT

16 A 32 a \$2 80

**HANDSOME AND GAY
Heiress of Paradise Alley**

12 POINT

18 A 36 a \$2 50

**JUMPING OVER DITCHES
Lively Dime Museum Freaks**

10 POINT

24 A 48 a \$2 65

**GREAT ANNUAL HORSE SALE
Blue Ribbon Parade Of Animals**

8 POINT

24 A 48 a \$2 30

**PREACHING TOUCHING SERMONS
Congregation Praising the Discourses**

6 POINT

32 A 64 a \$2 45

**HARVESTING THROUGH THE COUNTRIES
Farmers Employing all the Available Hands**

1234567890

1234567890

GOTHIC No 123

48 POINT

4 A 8 a \$9 00

GREAT HEAD
Morning Walk

36 POINT

5 A 10 a \$7 05

GOLDEN CHAIN
Beautiful Present

30 POINT

6 A 12 a \$6 25

JOYFUL VOICES RISE
Far Over the Mountain

24 POINT

10 A 20 a \$4 75

NEVER FAILS
Big Fish Story

18 POINT

12 A 24 a \$3 80

STEAM CHURN
Farmers Delight

12 POINT

18 A 36 a \$3 40

HONEST AND TRUE
Over the Garden Wall

10 POINT

20 A 40 a \$2 65

HANDSOME STRUCTURE
Beautiful American Temples

8 POINT

24 A 48 a \$2 50

SWEEPING HURRICANE DECKS
Then this Poor Man Began to Think
1234567890

6 POINT

32 A 64 a \$2 60

FASHIONABLE STREET PROMENADINGS
Our Brightest Hopes are the Most Fleeting
1234567890

GOTHIC No 124

48 POINT

4 A 6 a \$7 65

Evening RIGS

36 POINT

5 A 8 a \$5 75

NORTH OMAHA
Mountain Stream

30 POINT

6 A 10 a \$5 15

FRESH LOBSTERS
Consumptive Maids

24 POINT

8 A 16 a \$4 50

CONVENES
Faith Healer

18 POINT

12 A 24 a \$3 50

MASKED DANCE
Paving of Pathways

12 POINT

16 A 36 a \$2 50

MOONLIGHT MUSICALES
Spanish American Transports

10 POINT

20 A 40 a \$2 10

SEASONS RAPIDLY DEPARTED
Noble Deeds Live and Never Fade

8 POINT

24 A 48 a \$2 05

EXPORTATIONS GREATLY INCREASE
Advance Payments Demanded from All

6 POINT

32 A 64 a \$2 15

EASTERN HAND SPINNING COTTON WHEEL
Modern Machinery Supersedes every Antique Method

LINING GOTHIC No 43

36 POINT

8 A 9 a \$7 10

FATAL Combats

30 POINT

8 A 12 a \$6 00

Headmost BEAUS

24 POINT

10 A 15 a \$5 20

MODERN Homestead

18 POINT

14 A 25 a \$4 95

CRUISE
Ocean Waves

12 POINT

25 A 40 a \$4 20

INGENIOUS
Automatic Machine

9 POINT

36 A 50 a \$3 90

UNCOMBINED
Improved Roofing Material

8 POINT

36 A 55 a \$3 90

ADVANCEMENT
Sunshine of Prosperous Days

6 POINT No 417

60 A 70 a \$4 00

CELESTIAL HEMISPHERE
Inclinations of Base with the Horizon
Adjacent Angles and Distances

6 POINT No 416 C and l c

60 A 70 a \$3 70

MICROSCOPIC INDICATIONS
Calculations made by Illustrious Astronomers
Changes in Atmospheric Strata

6 POINT No 415

60 A \$2 25

INACCURATE GEODETIC OPERATIONS
DOUBTFUL CIRCUMFERENCE OF THE TERRESTRIAL SPHERE
CONSIDERED BY EXPERT MATHEMATICIANS

1 2 3 4 5 6 7 8 9 0

6 POINT No 414

60 A \$2 25

TRIANGULATION OF THE MERIDIAN
SUPERIORITY OF THE MODERN INSTRUMENTS FOR MEASUREMENT
IMPROVED METHODS AND APPLIANCES ADOPTED

1 2 3 4 5 6 7 8 9 0

LINING GOTHIC No 44

36 POINT

8A 8a \$7 65

STATE Burden

30 POINT

8A 12a \$6 95

Mounted SHEIKS

24 POINT

10A 15a \$5 65

TRAINED Elephants

18 POINT

14A 22a \$4 75

Emancipated PATAGONIAN

12 POINT

22A 40a \$4 10

ASCENDING
Beautiful Pathways

10 POINT

28A 45a \$4 05

TOURISTS
Discover Ancient Ruins

8 POINT

38A 55a \$3 80

RECONSTRUCTING
Stringent Fireside Regulation

6 POINT No 422

50A 70a \$4 45

SOCIAL GATHERINGS
Harmony and Sunshine Displayed

6 POINT No 421

50A \$2 35

GENDARMES SUMMONED
LIGHTFINGER'S BRIGANDS TAKEN

6 POINT No 420

50A \$1 70

MOONSTRUCK BURGLARS
SLEIGHS BROUGHT INTO REQUISITION

6 POINT No 419

50A \$1 40

POLICEMEN HUNTING INVADERS
ANGRY HOUSEWIFE OVERHAULING BUREAUS
1234567890

6 POINT No 418

50A \$1 35

CARELESS BOLTING OF FRONT DOORS
RECOMMENDED BY PROFESSOR LIGHTFINGER
1234567890

LINING GOTHIC No 45

36 POINT

4A 7a \$6 80

FINE Singers

30 POINT

6A 9a \$6 35

Morning DAWN

24 POINT

8A 12a \$5 20

HEROIC Adventure

18 POINT

12A 18a \$4 45

Roving FOREIGN Waters

12 POINT

20A 30a \$4 00

GRECIAN Damsels Adopted

9 POINT

25A 45a \$3 85

HUNTSMEN Spinning Fishing Yarns

8 POINT

36A 55a \$3 80

ROYSTERING Juveniles Charm and Delight

6 POINT No 427

45A 70a \$4 45

LIBERAL PENSION Decrepit Old Ringsters Disturbed

6 POINT No 426

45A \$2 10

MASTERLY RETREAT STRUGGLES AGAINST DESTINY

6 POINT No 425

45A \$1 90

SCENES AND INCIDENTS DINNER-TIME AMONG INSURGENTS

6 POINT No 424

45A \$1 55

BOILING GEYSER WATER ABANDONMENT OF FUEL FOR STEAM-POWER 1234567890

6 POINT No 423

45A \$1 45

RESOLUTIONS ON WARFARE ARMIES MUST NOT EXCEED FOUR HUNDRED MEN 1234567890

PHILADELPHIA LINING GOTHIC

48 POINT No 648

7 A 9 a \$6 50

MOTHERLY Inspirations

36 POINT No 636

8 A 10 a \$5 50

Cosmopolitan **SQUADRON**

30 POINT No 630

12 A 15 a \$5 00

ENTHUSIASTIC Parliamentarians

24 POINT No 624

16 A 24 a \$4 50

Fascinating Exterior **ORNAMENTATIONS**

18 POINT No 618

22 A 32 a \$4 25

GATECHUMEN
Educational Supremacy

14 POINT No 614

30 A 42 a \$4 00

DELIBERATIONS
Great and Eloquent Orator

12 POINT No 612

35 A 52 a \$3 75

BARTHOLDI STATUE
Liberty Enlightening the World

10 POINT No 610

45 A 60 a \$3 50

PRINTERS DELIGHTED
Astonishing Typographic Inventions

8 POINT No 608

52 A 70 a \$3 25

EQUINE SAGACITY OBSERVED
Modern Feline Trainer Electrifying Audience

6 POINT No 606

60 A 70 a \$3 00

MAGNIFICENT BUILDING OPERATIONS
Great Schemes Receive Liberal Public Opitulation
1 2 3 4 5 6 7 8 9 0

1 2 3 4 5 6 7 8 9 0

All sizes align at top and bottom of face.

PHILADELPHIA LINING GOTHIC

48 POINT NO 748

8 A 9 a \$7 50

REPORTS Believed

36 POINT NO 736

8 A 10 a \$6 50

Gorgeous **EXHIBITION**

30 POINT NO 730

10 A 15 a \$5 50

ANTIQUATED Construction

24 POINT NO 724

14 A 20 a \$4 75

Grand Operatic **ENTERTAINMENT**

18 POINT NO 718

18 A 28 a \$4 50

DESTROYED
Western Entrance

14 POINT NO 714

25 A 35 a \$4 25

HANDSOMEST
Presents Exchanged

12 POINT NO 712

30 A 45 a \$4 00

SUPERB LECTURE
Patronized by Juveniles

10 POINT NO 710

35 A 50 a \$3 75

PROUD SENTIMENT
Youths Declining Invitations

8 POINT NO 708

45 A 60 a \$3 50

GUARDIANS FRIGHTENED
Serious Results from Extravagance
1234567890

6 POINT NO 706

50 A 60 a \$3 25

INGENIOUS CONTRIVANCE
Plan to Avoid Detection During Absence
1234567890

All sizes align at top and bottom of face.

PHILADELPHIA LINING GOTHIC

48 POINT NO 848

6A 8a \$8 50

PUBLIC Service

36 POINT NO 836

7A 10a \$7 00

National PROTEST

30 POINT NO 830

9A 12a \$6 00

SECTIONAL Grievances

24 POINT NO 824

14A 20a \$5 25

Emblematic CONTEMPLATION

18 POINT NO 818

16A 26a \$4 75

STARLIGHT
Buxom Ramblers

14 POINT NO 814

25A 35a \$4 50

KNOWLEDGE
Napoleonic Copyist

12 POINT NO 812

30A 42a \$4 25

HARMONIOUS
Flowery Garden Spots

10 POINT NO 810

35A 50a \$4 00

CONSIDERATION
Golden Rules of Obalsance

8 POINT NO 808

45A 60a \$3 75

MONETARY VALUES
Upholding the Credit of Nations
1234567890

6 POINT NO 806

45A 60a \$3 50

MISREPRESENTATION
Humanity is Susceptible to Blarney
1234567890

All sizes align at top and bottom of face.

PHILADELPHIA LINING GOTHIC

48 POINT No 948

5 A 7 a 88 50

WAVE Depart

36 POINT No 936

6 A 9 a 87 00

Northern HOME

30 POINT No 930

8 A 10 a 86 00

PATRIOT Embarked

24 POINT No 924

12 A 16 a 85 25

Advertisement PRINTED

18 POINT No 918

14 A 22 a 84 75

PAINTED
Winter Scene

14 POINT No 914

20 A 30 a 84 50

MODERN
Design Admired

12 POINT No 912

25 A 38 a 84 25

REGIMENT
Mountain Fortress

10 POINT No 910

30 A 45 a 84 00

REDUCTIONS
During Holiday Season

8 POINT No 908

38 A 50 a 83 75

TRANSPORTATION
Declined by Foreign Visitor
1234567890

6 POINT No 906

40 A 50 a 83 50

COMPANIES ORGANIZED
Frolics Beneath a Starry Heaven
1234567890

All sizes align at top and bottom of face.

PHILADELPHIA LINING GOTHIC

48 POINT NO 1048

4 A 6 a \$9 25

NICE Robes

36 POINT NO 1036

6 A 8 a \$7 75

Rapid DREAM

30 POINT NO 1030

7 A 10 a \$6 50

HONEST Games

24 POINT NO 1024

10 A 15 a \$5 50

Charming MUSICALE

18 POINT NO 1018

14 A 20 a \$5 00

**OBLIQUE
Short Lanes**

14 POINT NO 1014

18 A 26 a \$4 75

**PRECIOUS
Crown Jewels**

12 POINT NO 1012

22 A 30 a \$4 50

**PROVERBS
Forget Injustice**

10 POINT NO 1010

25 A 40 a \$4 25

**DEPICTING
Dramatic Elevation**

8 POINT NO 1008

35 A 45 a \$4 00

**CALIFORNIAN
Discovery of Gold Mines
12345678**

6 POINT NO 1006

38 A 50 a \$3 75

**NURSERY EDIBLES
Promoters of Epicureanism
1234567890**

All sizes align at top and bottom of face.

PHILADELPHIA LINING GOTHIC

48 POINT NO 1148

4 A 6a \$10 00

RED Mask

36 POINT NO 1136

5 A 9a \$8 50

Sound MIND

30 POINT NO 1130

7 A 10a \$7 00

HOME Comfort

24 POINT NO 1124

10 A 15a \$6 00

Ornament BROKEN

18 POINT NO 1118

12 A 18a \$5 25

**DROVE
Tame Herd**

14 POINT NO 1114

16 A 26a \$5 00

**CHANGE
Fickle Maids**

12 POINT NO 1112

20 A 32a \$4 75

**BATHERS
Heated Season**

10 POINT NO 1110

25 A 40a \$4 50

**FORTUNATE
Reporter Engaged**

8 POINT NO 1108

35 A 45a \$4 25

**CELEBRATION
Gathering of Speakers
12345678**

6 POINT NO 1106

35 A 50a \$4 00

**GENTLE EXERCISE
Developing the Youngster
1234567890**

All sizes align at top and bottom of face.

PHILADELPHIA LINING GOTHIC

48 POINT No 1248

4A 5a \$9 25

DIN Heard

36 POINT No 1236

5A 7a \$7 75

Noted MEN

30 POINT No 1230

6A 9a \$6 50

SHOE Marked

24 POINT No 1224

9A 12a \$5 50

Damaged BENCH

18 POINT No 1218

12A 15a \$5 00

MATCH
Burn Cord

14 POINT No 1214

14A 22a \$4 75

MUSING
Comic Song

12 POINT No 1212

18A 28a \$4 50

NOISOME
Martial Sound

10 POINT No 1210

22A 35a \$4 25

REPORTS
Sporting Writers

8 POINT No 1208

28A 42a \$4 00

INSTRUCTIONS
Educated Mechanics
12345678

6 POINT No 1206

30A 45a \$3 75

CONGREGATION
Delighted with Sermons
1234567890

All sizes align at top and bottom of face.

PHILADELPHIA LINING GOTHIC

48 POINT No 1348

3 A 4 a \$10 00

SIX Bats

36 POINT No 1336

4 A 6 a \$8 50

New SITE

30 POINT No 1330

6 A 8 a \$7 00

MAY Parties

24 POINT No 1324

7 A 12 a \$6 00

Electric SHOCK

18 POINT No 1318

10 A 14 a \$5 25

**GLIDE
Fast Tide**

14 POINT No 1314

14 A 22 a \$5 00

**STRING
Lyric Poet**

12 POINT No 1312

18 A 28 a \$4 75

**BALSAM
Doctor Right**

10 POINT No 1310

20 A 35 a \$4 50

**PARKSIDE
Natural Scenes**

8 POINT No 1308

25 A 40 a \$4 25

**BIOGRAPHER
Historical Writings
1 2 3 4 5 6 7 8 9**

8 POINT No 1306

28 A 40 a \$4 00

**FASCINATION
Prodigious Magioloans
1 2 3 4 5 6 7 8 9**

All sizes align at top and bottom of face.

PHILADELPHIA LINING GOTHIC

48 POINT No 1448

3A 5a \$11 25

NO Rain

36 POINT No 1436

5A 7a \$9 75

Mark VAT

30 POINT No 1430

6A 9a \$8 25

TAKE Pains

24 POINT No 1424

9A 12a \$7 00

Steam WATCH

18 POINT No 1418

12A 15a \$6 00

**PAST
Fine Site**

14 POINT No 1414

15A 22a \$5 50

**WORN
Gold Rope**

12 POINT No 1412

16A 26a \$5 00

**DEPART
Slow Trains**

10 POINT No 1410

22A 32a \$4 75

**PARDON
Honest People**

8 POINT No 1408

25A 40a \$4 50

**DESIRABLE
Beautiful Designs
1234567**

6 POINT No 1406

28A 45a \$4 25

**GUARDSMEN
Exhausted Regiment
12345678**

All sizes align at top and bottom of face.

LINING GOTHIC EXTENDED No 40

36 POINT

4A 6a \$7 10

FAST Race

30 POINT

5A 7a \$5 15

Beau MONDE

24 POINT

7A 10a \$4 50

**HARTFORD
Pleasure Steamer**

18 POINT

10A 14a \$4 30

**FAMILY GROUPS
Basking in Sunbeams**

14 POINT

12A 18a \$3 50

**MODERN SAYINGS
Phonographs Recharged**

12 POINT

14A 22a \$3 40

**DEMANDS
Money Loans**

10 POINT

16A 24a \$3 10

**MONARCHS
Create Blunders**

8 POINT

20A 30a \$3 00

**TEARQUICK
Fashionable Gaskins
1234567**

6 POINT

25A 35a \$3 00

**PREDETERMINE
Eager Bargain Hunters
12345678**

GOTHIC WIDE

36 POINT

5 A \$6 30

DIRECTOR

30 POINT

5 A \$4 55

AMERICANS

24 POINT

6 A \$3 85

FALL DESIGNS

20 POINT

10 A \$3 80

BARGAIN SEEKER.

16 POINT

8 A \$2 45

BRASS ORNAMENTS

12 POINT

12 A \$2 30

10 POINT

14 A \$1 80

WELCOME SCANDALOUS

8 POINT

16 A \$1 70

6 POINT

22 A \$2 55

ELECTRIC CARS MITERING MACHINES

5½ POINT ON 6 POINT

35 A \$2 35

5 POINT ON 6 POINT

35 A \$2 05

USEFUL ADVERTISING EXTENSIVE IMPROVEMENTS

4 POINT ON 6 POINT

35 A \$2 00

3½ POINT ON 6 POINT

35 A \$2 00

STOCKHOLDERS OF COMPANY
1234567890SELECT DESIGNS FOR COMPOSITORS
1234567890

GOTHIC WIDE No 2

24 POINT

5 A 7 a \$5 80

→* NATION *←
 Mexican Border
 Herders

20 POINT

6 A 10 a \$4 95

→* BUILDING *←
 Suburban * Homes
 Domiciled

16 POINT

8 A 12 a \$4 20

→* MEETINGS *←
 Annual * Nominations
 Candidates

12 POINT

12 A 18 a \$4 15

FRENCH
 Entertainer
 Bonds

10 POINT

14 A 20 a \$3 15

BANQUET
 Choice Dinner
 Lunch

8 POINT

16 A 28 a \$3 20

→* PACKET *←
 American * Boats
 12345678

6 POINT

22 A 32 a \$3 05

→* PEDESTRIAN *←
 Outdoor * Amusement
 1234567890

RONALDSON GOTHIC

48 POINT

5 A 7 a \$7 15

Pleasant DREAM

36 POINT

6 A 9 a \$5 80

Sugar CANDY Gratis

30 POINT

8 A 12 a \$4 95

OLDENTIME Observance

24 POINT

10 A 15 a \$3 70

Splendid PRESENTS Displayed

18 POINT

12 A 18 a \$3 15

OVERFLOWING
Family Blessings

14 POINT

18 A 28 a \$3 15

REMEMBERING
Mannerly Younkers

12 POINT

22 A 34 a \$3 10

AFTER DINNER
Boisterous Enjoyment
Shared by Adults

10 POINT

28 A 45 a \$3 10

MODEST MAIDENS
Courteous and Polite Girls
Womanhood Adored

8 POINT

38 A 55 a \$3 10

KRISS KRINGLE ANTICS
Wriggling Down Narrow Chimneys
1 2 3 4 5 6 7 8 9 0

6 POINT

40 A 60 a \$3 10

WELCOME AS SPRINGTIME
Opportunities to Please the Children
1 2 3 4 5 6 7 8 9 0

BINNER GOTHIC

72 POINT

5 A 8 a \$9 00

FARMERS Inauguration

60 POINT

7 A 10 a \$8 00

Manufacturers EXPENDITURE

48 POINT

8 A 12 a \$7 00

DISTINGUISHED Artistic Thermometer

36 POINT

10 A 15 a \$6 00

MODERN RAILROAD
Delights Excursionists

30 POINT

12 A 18 a \$5 00

PERMANENT INVESTMENT
Eastern Nistorical Society

24 POINT

14 A 20 a \$4 00

BURNING ELEVATORS UNNOTICED
Mild Languor of Soft Brown Eyes
1234567890

18 POINT

18 A 27 a \$3 25

ADMIRER BEAUTIFUL FOLDING SLEEVES
Funeral Services Held Over Dead Soldiers
1234567890

OCTIC No 2

42 POINT 4 A \$4 25

ROBE

36 POINT 5 A \$3 80

MIGHT

30 POINT 6 A \$3 20

CRIMES

24 POINT 8 A \$2 95

POINTER

20 POINT 8 A \$2 30

PREMISES

18 POINT 12 A \$2 25

RARE BIRDS

16 POINT 15 A \$2 40

CUBAN HOME

12 POINT 20 A \$2 10

PURE BOURBON

10 POINT 30 A \$2 00

RICHWOOD TIMBER

8 POINT 30 A \$1 95

EIGHT CORNER QUADS

6 POINT 30 A \$1 60

SOUTHERN FRUIT GROWER
1234567890

OCTIC No 1

48 POINT 4 A \$6 35

FIRE

42 POINT 4 A \$4 40

COST

36 POINT 5 A \$4 40

CHOIR

30 POINT 6 A \$3 00

BRIDGE

24 POINT 8 A \$3 00

PAINTER

20 POINT 8 A \$2 30

REPORTER

16 POINT 15 A \$2 00

PAINT BRUSH

12 POINT 20 A \$2 00

SANDY GROUND

10 POINT 20 A \$1 45

TOBACCO GROWERS

8 POINT 30 A \$2 00

WAGON MANUFACTURE

6 POINT 30 A \$1 50

FINE MOROCOO BOUND BOCKB
1234567890

ROUND GOTHIC

60 POINT

5 A 8 a \$12 30

MINE Hunters

48 POINT

7 A 10 a \$11 70

General DEPOTS

36 POINT

10 A 14 a \$7 70

AUTUMN Amusements

28 POINT

12 A 18 a \$6 70

Enlarged Harbor DREDGING

24 POINT

14 A 20 a \$5 50

Theatre BURNS

22 POINT

18 A 24 a \$5 15

Practical TRADER

18 POINT

18 A 28 a \$3 80

EARNEST Legislature

14 POINT

22 A 42 a \$3 70

PASTORAL Requirements

12 POINT

22 A 42 a \$3 05

Recollections of MERRIMENT

11 POINT

36 A 52 a \$3 15

Crimson Muslin and DECORATIONS

10 POINT

36 A 52 a \$2 75

INVESTIGATING Committee on Finance

8 POINT

36 A 70 a \$2 85

SCAVENGER FOUND Working before Supper

7 POINT

36 A 70 a \$2 65

Empty Pocket Filled by BENEFIT ASSOCIATION

6 POINT

52 A 70 a \$2 70

Improved Dress Styles Sold on REASONABLE TERMS

1234567890

1234567890

72 Point, 5A 6a \$17.50, also furnished

DORIC ITALIC

60 POINT

4 A 5 a \$15 50

The END

48 POINT

4 A 5 a \$10 75

DOG Carts

36 POINT

5 A 7 a \$8 75

Crowd LARGE

30 POINT

5 A 7 a \$6 50

SPECIAL Markets

24 POINT

6 A 10 a \$5 00

Cheap VEST

18 POINT

8 A 12 a \$4 50

Meney FOUND

12 POINT

10 A 20 a \$4 25

***RECOGNITION
Entertain Nebleman***

10 POINT

12 A 25 a \$4 00

***HOSTILE TRIBES
Prepare Twenty Braves***

8 POINT

15 A 30 a \$3 75

***LEOTURING OOURSES
Members Securing Tikots
1234567890***

8 POINT

18 A 40 a \$3 50

***AMBITIOUS AUSTRALIAN
Promises Many Business Chances
1234567890***

COMBINATION ITALIC GOTHIC

48 POINT No 150

4 A \$4 00

DEALER WEIGH

36 POINT No 149

6 A \$3 40

PLEASING CONCERTS

24 POINT No 138

8 A \$2 50

DISTRICT BOARD ELECTED

24 POINT No 137

10 A \$2 25

HANDLING STOLEN OVERSHOES

18 POINT No 136

14 A \$2 00

*KNOWLEDGE
CROUPERS BROKEN*

12 POINT No 135

16 A \$1 40

*STRONG ATHLETES
ASSOCIATIONS JUBILANT*

12 POINT No 134

20 A \$1 40

*HANDSOME STRUCTURE
BEAUTIFUL MASONIC TEMPLES*

12 POINT No 133

24 A \$1 40

*FOREIGNERS IMPORTING
AMERICAN STEAMSHIPS CONTESTED*

6 POINT No 132

30 A \$1 35

*CONGRESSIONAL QUESTIONS
REPRESENTING NORTHERN MEMBERSHIP
1 2 3 4 5 6 7 8 9 0*

6 POINT No 131

40 A \$1 35

*DELIGHTFUL DECEMBER SKATING
BANQUET OF THE CANADIAN SNOWSHOE ASSOCIATION
1 2 3 4 5 6 7 8 9 0*

GOTHIC ITALIC SERIES

0-12

60 POINT NO 123

3 A 6 a \$9 60

GRAND Army

48 POINT NO 123

4 A 8 a \$7 80

Managers POOR

36 POINT NO 123

5 A 10 a \$6 40

UNHAPPY Children

30 POINT NO 112

10 A 14 a \$4 50

RENOWNED OFFICERS
Prominent American Senator

20 POINT NO 112

18 A 24 a \$3 65

POPULAR DESIGN
Beautiful Specimen

18 POINT NO 112

18 A 25 a \$2 80

COURAGEOUS FIGHTERS
Grand Army Encampment

12 POINT NO 112

22 A 38 a \$2 50

HARMONIOUS COMBINATIONS
Fancy Typographic Decoration

10 POINT NO 112

30 A 42 a \$2 60

UNPRECEDENTED INDUCEMENTS
Extraordinary Bargains Extended

8 POINT NO 112

36 A 52 a \$2 60

PLEASANT STEAMBOAT EXCURSIONS
Lovely Sights Mid Picturesque Valleys
1234567890

6 POINT NO 113

30 A 60 a \$2 40

DISTINGUISHED AMERICAN STATESMEN
Berlin Historical and Poetical Association
1234567890

INCLINED GOTHIC

24 POINT

8 A \$3 00

JUBILEE SONG

18 POINT

12 A \$2 50

MUSICAL CHILDREN

16 POINT

14 A \$2 25

**MASSACHUSETTS
EDITORIAL ASSOCIATION**

12 POINT

20 A \$2 00

**FAMOUS STATESMEN
ASSEMBLED IN CONFERENCE**

10 POINT

24 A \$1 75

**NUMEROUS PEOPLE
WITNESS THE GRAND NAVAL DISPLAY**

8 POINT

26 A \$1 50

**EXTRAORDINARY ATTRACTION
PERFORMING ELEPHANT BATHING IN RESERVOIR**

6 POINT No 7

28 A \$1 25

**MOUNT WASHINGTON
VIEWED BY EXCURSIONISTS**

6 POINT No 6

30 A \$1 25

**INDEPENDENT CITIZENS
FAVORABLE TO RAPID TRANSIT**

6 POINT No 5

32 A \$1 25

**NAVIGATION SUSPENDED
BETWEEN TWILIGHT AND MIDNIGHT
1234567890**

6 POINT No 4

34 A \$1 25

**CIRCUMSTANTIAL EVIDENCE
PRODUCED BY THE DISTRICT ATTORNEY
1234567890**

GOTHIC ITALIC No 124

24 POINT

10 A \$1 15 10 A 20 a \$3 20

MADAME TATTLERS BOARDING SCHOOL
Big Turkey Gobbler Stuffed WITH OYSTERS

18 POINT

12 A \$0 95 12 A 24 a \$2 95

SOUTH AMERICAN SILVER MINING COMPANIES
Competency Acquired by Distributing GOLD COIN

12 POINT

18 A \$0 90 18 A 36 a \$2 55

MORPHINE EVENTUALLY WARRANTED TO KILL THE USERS
General Views of the Confirmed Loafers DO-NOTHING SOCIETY

10 POINT

24 A \$0 85 24 A 48 a \$2 65

GIVING GOOD PRONUNCIATIONS
Superintendents are RESPONSIBLE

8 POINT

24 A \$0 70 24 A 48 a \$2 20

REPRESENTING BUSINESS INTERESTS
Being Produced by GENERAL ASSEMBLIES

6 POINT

32 A \$0 75 32 A 64 a \$2 25

BANQUET OF THE CANADIAN SNOW-SHOE CLUB
Scenery Along the Boulevard near FORT SHERIDAN
 1234567890

5 POINT ON 6 POINT 32 A \$0 85 32 A 64 a \$1 95

HIS CONVICTION UPON CIRCUMSTANTIAL TESTIMONY
The Breadth and Depth of Social FASHION UPON SOCIETIES
 1234567890

Small Caps not sent unless expressly ordered

GOTHIC SLOPE No 20

22 POINT

10 A 22 a \$3 50

QUICKSAND
Wrecking Mountain

18 POINT

14 A 32 a \$3 25

TYPOGRAPHICAL
Government Bombshells

12 POINT

20 A 40 a \$3 00

YOUNGEST DOMESTIC
Hustling Graduates are Preparing

10 POINT

22 A 50 a \$2 75

CONVERTING RASCALITY
Progressive and Healthiest Orations

8 POINT

28 A 56 a \$2 50

GENEROUS AMERICAN WORKMEN
Honorably Discharged United States General
 1234567890

6 POINT

30 A 60 a \$2 25

HANDLING MORTGAGED PROPERTY
Seldom Encounter California Mountain Driveways
 1234567890

GOTHIC ITALIC EXTRA CONDENSED

42 POINT

8A 10a \$7 00

CONTAMINATE *Correspondents*

36 POINT

9A 12a \$6 00

Blackened Character *WHITEWASHED*

30 POINT

10A 14a \$5 00

MEDDLESOME YOUTHS *Lively Expert Players*

24 POINT

12A 16a \$4 25

Characteristic Charities *EARNESTLY PROTESTED*

20 POINT

15A 20a \$4 00

TOOTHsome DELICACIES *Devoured With Great Rapidity*

16 POINT

18A 24a \$3 75

Numerous Selections From the *VERY BEST STANDARD AUTHORS*

12 POINT

20A 30a \$3 40

COLLECTING ANTIQUITIES
Quaint and Curious Old Specimens

10 POINT

24A 36a \$3 25

PRINCELY SALARY PAID
Superintendent Who has Responsibility

8 POINT

26A 38a \$3 00

SILVER MOON RESTAURANT
A Famous Western Hostelry in Days Gone By
1 2 3 4 5 6 7 8 9 0

6 POINT

28A 40a \$2 50

PECULIAR PRONUNCIATION CONDEMNED
Plain Simple Style of Conversation Much More Preferable
1 2 3 4 5 6 7 8 9 0

McCULLAGH SERIES

72 POINT

3 A 5 a \$9 50

HOUR CLOCKS

60 POINT

3 A 5 a \$8 50

Antique BARGE

48 POINT

4 A 7 a \$6 50

**CHIVALROUS
Mountain Climbers**

42 POINT

5 A 8 a \$6 00

**UNGOVERNABLE
Conditions Described**

McCULLAGH SERIES

36 POINT

6 A 9 a \$5 80

ROAMING AMAZONS
Nomadic Habits Unenvied

30 POINT

7 A 10 a \$4 25

INGENIOUS MECHANICS
Handsome Lakeview Residence

24 POINT

8 A 12 a \$4 00

DOCTORS EDITING JOURNALS
Renowned Medical Manuals Published

18 POINT

10 A 14 a \$3 25

DEMANDING EXORBITANT INTEREST
Conventional Inducement of Investment Company

12 POINT

16 A 20 a \$3 00

BENEVOLENT GOVERNMENT
Wounded Combatants Pensioned
1 2 3 4 5 6 7 8 9 0

10 POINT

20 A 26 a \$2 75

ENTERTAINING SOCIETY MAIDENS
Admiring Juvenile Comedians Simplicity
1 2 3 4 5 6 7 8 9 0

QUENTELL SERIES

72 POINT

4A 5a \$17 00

MENS Club

60 POINT

4A 5a \$12 25

Count GIRLS

54 POINT

4A 5a \$10 25

QUICK Return

48 POINT

4A 5a \$7 75

Order GENERAL

42 POINT

4A 6a \$7 25

**EXCURSIONS
Divorce Register**

QUENTELL SERIES

36 POINT

5 A 8 a \$5 50

PERFORMANCES
Remarkable Country

30 POINT

6 A 9 a \$5 00

CORRESPONDENCE
Distinguished Questions

24 POINT

8 A 10 a \$4 00

ENTERPRISING MERCHANT
Sending Phonograph Message

18 POINT

10 A 16 a \$3 25

UNREALIZATION
Beautiful Floriated

14 POINT

12 A 18 a \$3 25

BASEBALL GAMES
Enchanted Amusement

12 POINT

16 A 20 a \$3 00

POCKET ESTIMATE
Provocation and Sensation

10 POINT

20 A 26 a \$2 75

PHOTOGRAPHERS RESOLUTION
Beautiful, Glorious and Charming

8 POINT

22 A 30 a \$2 50

THROUGH COUNTLESS DANGERS
Charitable Society Distributing Clothing
1 2 3 4 5 6 7 8 9 0

6 POINT

24 A 36 a \$2 25

PATENT CYLINDER PRINTING MACHINE
Magnificent Assortment Woodwork Exhibited
1 2 3 4 5 6 7 8 9 0

QUENTELL FRACTIONS

1/4 1/2 3/4 1/8 3/8 5/8 7/8 1/3 2/3

PRICES: 6 POINT TO 24 POINT, INCLUSIVE, 50 CTS. PER FONT; 30 POINT AND 36 POINT, 75 CTS. PER FONT.
Made for all sizes on this page.

DE VINNE SERIES

72 POINT

4 A 5 a \$17 00

Iron RIM

60 POINT

4 A 5 a \$12 25

TIN Block

54 POINT

4 A 5 a \$10 25

Silver ORE

48 POINT

4 A 5 a \$7 75

GUM Covers

42 POINT

4 A 5 a \$7 25

Comical SONG

36 POINT

5 A 8 a \$5 50

SPRING Bonnets

For De Vinne Poster Fonts, see pages 522 and 523

DE VINNE SERIES

30 POINT

6 A 9 a \$5 00

Harvesters REAPING

24 POINT

8 A 10 a \$4 00

**MASSACHUSETTS
Philanthropic Associations**

18 POINT

10 A 16 a \$3 25

**WILDCAT INVESTMENT
Unsuccessful Business Transaction**

14 POINT

12 A 18 a \$3 25

**INTERNATIONAL HOSPITALITY
Receptions and Suppers to Foreign Visitors**

12 POINT

16 A 20 a \$3 00

**SHARPSHOOTER
Professional Marksman**

10 POINT

20 A 26 a \$2 75

**DEVELOP MUSCLES
Healthful Gymnastic Exercise**

8 POINT

22 A 30 a \$2 50

**ROMANTIC SCENERY
Beautiful Mountainous Landscapes**

7 POINT

22 A 34 a \$2 50

**BRAVE SAILORS SAVED
Sunshine Brings Happiness to Mariners**

6 POINT

24 A 36 a \$2 25

**HONORABLE COMPETITION
Amateur Athletes Receive Encouragement
1 2 3 4 5 6 7 8 9 0**

5½ POINT

24 A 36 a \$2 50

**BARGAINS IN MACKINTOSHES
People Who are Always Without Umbrellas
1 2 3 4 5 6 7 8 9 0**

DE VINNE FRACTIONS

¼ ½ ¾ ⅓ ⅔ ⅛ ⅜ ⅝ ⅞ ¢ % ¼ ½ ¾ ⅓ ⅔ ⅛ ⅜ ⅝ ⅞ ¢ %

MADE IN ALL SIZES FROM 6 POINT TO 24 POINT, INCLUSIVE. PRICE, 50 CENTS PER FONT

For De Vinne Poster Fonts, see pages 522 and 523

DE VINNE CONDENSED

PATENTED

72 POINT

4 A 5 a \$15 00

RICH Print

60 POINT

4 A 5 a \$10 00

Sharp SHOD

54 POINT

4 A 5 a \$7 50

WORD Marks

48 POINT

4 A 5 a \$6 00

Greater GAMES

42 POINT

4 A 6 a \$5 00

DOUBLE Machine

36 POINT

5 A 8 a \$5 00

Moustache GROWING

For De Vinne Condensed Poster Fonts, see pages 524 and 525

DE VINNE CONDENSED

PATENTED

30 POINT

6A 9a \$4 50

CRIMSON CLOUDS
Moving Swiftly Northward

24 POINT

8A 12a \$4 00

BENJAMIN FRANKLIN
Greatest Energetic Achievements

18 POINT

10A 16a \$3 25

FERTILE GARDEN DRENCHED
Rainmakers Incessantly Supplied Moisture

14 POINT

12A 20a \$3 25

MERCHANTS NATIONAL FRATERNITY
Grand Complimentary Summer Railroad Excursions

12 POINT

18A 22a \$3 00

SHOCKING MODESTY
Enormous Masculine Bloomers

10 POINT

22A 30a \$2 75

EXHIBITING ARCHITECTURE
Cotton States International Exposition

8 POINT

25A 36a \$2 50

MATHEMATICAL CALCULATION
Foretells Severe Atmospheric Disturbances
1234567890

6 POINT

30A 42a \$2 25

BRIGHT MORNING SUNLIGHT SHINES
Contemplating Miscellaneous Telescopic Observations
1234567890

DE VINNE CONDENSED FRACTIONS

$\frac{1}{4}$ $\frac{1}{2}$ $\frac{3}{4}$ $\frac{1}{8}$ $\frac{3}{8}$ $\frac{5}{8}$ $\frac{7}{8}$ $\frac{1}{3}$ $\frac{2}{3}$ $\frac{1}{4}$ $\frac{1}{2}$ $\frac{3}{4}$ $\frac{1}{8}$ $\frac{3}{8}$ $\frac{5}{8}$ $\frac{7}{8}$ $\frac{1}{3}$ $\frac{2}{3}$

MADE IN ALL SIZES FROM 6 POINT TO 36 POINT INCLUSIVE PRICES 6 POINT TO 24 POINT, INCLUSIVE, 80 CTS. PER FONT: 30 POINT AND 36 POINT, 75 CTS. PER FONT.

For De Vinne Condensed Poster Fonts, see pages 524 and 525

DE VINNE EXTRA CONDENSED

PATENTED

72 POINT

4 A 5 a \$15 00

NOBLE Horses

60 POINT

4 A 5 a \$9 00

Brought ROCKER

54 POINT

5 A 7 a \$8 00

DURABLE Flooring

48 POINT

5 A 8 a \$7 00

Landscape IMPROVED

42 POINT

6 A 10 a \$6 00

MODERN CUISINE
Clothed in Deep Mystery

DE VINNE EXTRA CONDENSED

PATENTED

36 POINT

6 A 12 a \$5 50

COLLEGE MONTHS
Bright Maidens in Attendance

30 POINT

8 A 12 a \$5 00

NUMEROUS LANDMARKS
Throughout Cumberland Discovered

24 POINT

10 A 16 a \$4 00

INNUMERABLE REQUISITIONS
Administration Upholding Monroe Doctrines

18 POINT

12 A 20 a \$3 25

DISPLAY BEAUTIFUL FLORAL DESIGNS
Seventh Annual International Chrysanthemum Exhibit
Handsome Flowers Displayed

14 POINT

18 A 22 a \$3 25

NATIONAL CONVENTION
Mississippi Valley Metropolis
1234567890

12 POINT

20 A 26 a \$3 00

VENEZUELAN COMMISSION
Arbitration Now Becomes Necessary
1234567890

DE VINNE EXTENDED

48 POINT

3 A 4 a \$11 50

HOME
Fashions

42 POINT

4 A 5 a \$10 00

FARMS
Fine Cattle

36 POINT

4 A 6 a \$8 00

SPRING
Sugar Barrel

30 POINT

5 A 8 a \$7 00

INDUSTRY
Missouri Firms

DE VINNE EXTENDED

24 POINT

6A 10a \$6 00

EXPOSITION
Home Manufacture

18 POINT

9A 12a \$4 50

UNIFORM PRINT
Looks Plain and Artistic

14 POINT

10A 14a \$3 75

BEAUTIFUL SCENE
Views From Excursion Boats

12 POINT

14A 18a \$3 50

NINETEENTH CENTURY
Base Ball and Lawn Tennis Player

10 POINT

18A 24a \$3 00

EUROPEAN BICYCLE EXHIBITION
American Products Receive Highest Awards
Enterprising Competitors

8 POINT

22A 30a \$2 75

MODEST YOUTHS
Introduced to Director
Gratifying Result
12345678

6 POINT

24A 36a \$2 50

JUVENILE ORCHESTRA
Renders Popular Selections
Thursday Evening
1234567890

DE VINNE ITALIC

PATENTED

72 POINT

4 A 5 a \$19 00

Lost RIG

60 POINT

4 A 5 a \$13 25

RUN Fast

54 POINT

4 A 5 a \$11 25

Read NICE

48 POINT

4 A 5 a \$7 75

BEAR Skins

42 POINT

4 A 6 a \$7 25

Beaver DIVES

36 POINT

5 A 8 a \$6 50

GRAND Festival

DE VINNE ITALIC

PATENTED

30 POINT

6 A 9 a \$5 75

***BLUSTERING
Destructive Cyclones***

24 POINT

8 A 10 a \$4 50

***FIRING ROCKETS
Distress Signals Answered***

18 POINT

10 A 16 a \$4 00

***WANDERING ARABIANS
Experienced Numerous Hardships***

14 POINT

12 A 18 a \$3 25

***DELIGHTFUL HOLIDAY SEASON
Society Whirlwinds Unceasingly Blowing
Frivolous Dames Dancing***

12 POINT

16 A 20 a \$3 00

***UNDERSTANDS
Thoroughly Mechanical***

10 POINT

20 A 26 a \$2 75

***ARMENIAN MASSACRE
Turkish Cruelty Shows Plainly***

8 POINT

22 A 30 a \$2 50

***CHICAGO WEEKLY NEWS
Universally Pronounced Brilliancy
1234567890***

6 POINT

24 A 36 a \$2 25

***AMERICAN TYPE FOUNDERS
Manufactures Superior Printing Materials
1234567890***

DE VINNE ITALIC OUTLINE

PATENTED

72 POINT

4 A 5 a \$17 00

Red INK

60 POINT

4 A 5 a \$12 25

HER Pets

54 POINT

4 A 5 a \$10 25

Little BOY

48 POINT

4 A 5 a \$7 75

DIRE Senate

42 POINT

4 A 6 a \$7 25

*RELIABLE
Hardy Planter**This Series will register for color printing with De Vinne Italic on pages 302 and 303*

DE VINNE ITALIC OUTLINE

PATENTED

36 POINT

5 A 8 a \$6 50

SPECIMEN

Printers Journal

30 POINT

6 A 9 a \$5 75

DEMONSTRATE

Handsome Furnisher

Conclusively

24 POINT

8 A 10 a \$4 50

SCARED

Farm Maids

18 POINT

10 A 16 a \$4 00

REPUBLIC

Italic Type Made
Outlined

14 POINT

12 A 18 a \$3 25

AGRICULTURE

Employing Farmer

13579

12 POINT

16 A 20 a \$3 00

CONTRIBUTOR

Receives Remuneration

1234567

This Series will register for color printing with De Vinne Italic on pages 302 and 303

DE VINNE SHADED

72 POINT

4A 5a \$17 00

HIS Dish

60 POINT

4A 5a \$12 50

Dead MET

54 POINT

4A 5a \$10 50

BIRD Catch

48 POINT

4A 5a \$7 75

Steak RANK

42 POINT

4A 6a \$7 50

TRIED Articles

36 POINT

5A 8a \$5 75

Lad HIT

24 POINT

8A 10a \$4 50

HARD Earth

18 POINT

10A 16a \$3 75

ACTOR Pleasing
12345678

12 POINT

16A 20a \$3 25

Triumphant CHARMER
1234567890

RIMPLED SERIES

PATENTED

48 POINT

4A 6a \$7 00

Decided CURE

36 POINT

5A 8a \$5 00

URGENT Medicines

30 POINT

6A 9a \$4 25

Prophylactic POWDER

24 POINT

8A 12a \$3 50

CONTENTMENT
Jocular Disposition Restored

18 POINT

12A 18a \$3 25

ENJOYMENT
Hopes Raised and
Sadness Dispelled

12 POINT

20A 30a \$3 00

ELBOW GREASE
Warranted to relieve all
persons of Indisposition
and Chronic Drowsiness

10 POINT

22A 35a \$2 75

WONDERFUL CEMENT
Nature's Remedy
For quickly curing Habitual
Gossiping in your neighbor
1 2 3 4 5 6 7 8 9 0

8 POINT

25A 40a \$2 50

BROKEN HEART BALSAM
Melancholic Lovers
When suffering from Heartache
should use this Soothing Balm
1 2 3 4 5 6 7 8 9 0

COLUMBUS No 2

PATENTED

60 POINT

3 A 4 a \$12 35

NO Card

36 POINT WITH 60 POINT INITIALS

RAISE Vines

48 POINT

3 A 5 a \$9 35

Same CAR

24 POINT WITH 48 POINT INITIALS

Chivalrous LADIES

36 POINT

5 A 8 a \$8 00

GAME Record

COLUMBUS No 2

PATENTED

24 POINT

10 A 15 a \$7 05

MORE Homes

18 POINT

15 A 20 a \$6 10

**ANIMATED
Fervent Comedian**

15 POINT

18 A 25 a \$5 00

**WINTER GAMES
Stormy Weather Endured**

12 POINT

25 A 35 a \$4 25

**HANDSOME STEAMER
Expedition Traveling Homeward**

10 POINT

26 A 40 a \$3 75

**ELECTRIC LIGHTING
Resplendent Spectacular Extravaganza**

8 POINT

30 A 45 a \$3 50

**SPARKLING OPERATIC COMEDY
Burlesque Company Received Great Applause**

6 POINT

35 A 50 a \$3 25

**FALLTIME CLOTHING SACRIFICED
Bargain Sale Advertised for Every Tuesday in March
1234567890**

18 POINT WITH 36 POINT INITIALS

Quaint SCENE

Columbus Initials

36 POINT \$2 00
48 POINT 3 00
60 POINT 4 00

B
C
E
F
K
L
O
Q
R
S
T
V
W

FFONTS CONTAIN THE ABOVE
CAPITALS ONLY

COLUMBUS OUTLINE

PATENTED

60 POINT

3 A 4 a \$12 35

Rendered
SONG

36 POINT WITH 60 POINT INITIALS

RAISE Vines

48 POINT

3 A 5 a \$9 35

CREAM
Fascination

This Series will register for color printing with Columbus No. 2 on pages 308 and 309

COLUMBUS OUTLINE

PATENTED

36 POINT

5 A 8 a \$8 00

Recreation
GAME

24 POINT WITH 48 POINT INITIALS

COLD Winds

24 POINT

10 A 15 a \$7 05

VISITOR
Modest Homes

18 POINT WITH 36 POINT INITIALS

Quaint SCENE

18 POINT

15 A 20 a \$6 10

ANIMATED
Fervent Comedian
1 2 3 4 5 6

*This Series will register for color printing with Columbus No. 2
on pages 308 and 309*

Columbus Outline
Initials

36 POINT \$2 00

48 POINT 3 00

60 POINT 4 00

B
C
E
F
K
L
Q
R
S
T
V
W

FFONTS CONTAIN THE ABOVE
CAPITALS ONLY

HOWLAND AND HOWLAND OPEN

PATENTED

4 A 5a \$9 00

60 POINT

4 A 5a \$9 50

HOMES 5 Great

4 A 6a \$8 00

54 POINT

4 A 6a \$8 50

BROKEN HEARTS

Pointed 38 Reason

5 A 8a \$7 00

48 POINT

5 A 8a \$7 50

YOUR BOSTON BOYS

America £17 Forever

6 A 10a \$6 00

42 POINT

6 A 10a \$6 50

PERIODICAL MOVEMENT

3 Modern Ideas Tremble 5

This Series will register for color printing

HOWLAND AND HOWLAND OPEN

PATENTED

8 A 12a \$5 00

30 POINT

8 A 12a \$5 50

RICHEST BANKER EXPIRES
Complicated 827 Machinery

10 A 16a \$4 00

24 POINT

10 A 16a \$4 50

STRANGE INHERITANCE QUESTION
89 Curious Treatment Foretold 78

12 A 20a \$3 25

18 POINT

12 A 20a \$3 50

INTEREST COUNTED 123456 DURING VACATIONS
Regular Investments Thoroughly Published

12 POINT

20 A 30a \$3 00

WOEFUL WITCH THEORY
Early Puritan Doctrines 49

12 POINT

20 A 30a \$3 00

WOEFUL WITCH THEORY
Early Puritan Doctrines 48

10 POINT

24 A 36a \$2 75

DELUDED RELIGIOUS CHRONIC
Drives People to Distraction \$260

10 POINT

24 A 36a \$2 75

DELUDED RELIGIOUS CHRONIC
Drives People to Distraction \$260

8 POINT

28 A 40a \$2 50

POPULAR PASTIMES THROWN OVER
Modern Society Shocked
Festive Board and 94 Ball Discouraged

6 POINT

30 A 50a \$2 25

HISTORY REVEALS HARD PUNISHMENT
Oaken Stocks and Cowhide Lashes
Terrible Deeds Rectified by Christianity 48

This Series will register for color printing

QUAINT SERIES

PATENTED

48 POINT

4 A \$4 00

GRAND · JOKER

36 POINT

6 A \$3 40

EVENING · SERMON

24 POINT

8 A \$2 90

THIRD · NATIONAL · BANK

18 POINT

10 A \$2 25

STRONG · AND · HEARTY
HISTORIC · CHESTNUT · SOCIETY

12 POINT

14 A \$1 90

REVIEWING GRAND PARADE
PHILADELPHIA · VETERAN · ASSOCIATION

10 POINT

20 A \$1 90

GOLD · AND · SILVER
RICH DIAMOND FIELDS
· 12345678 ·

8 POINT

24 A \$1 90

HUMPT · & · DUMPT
DEALERS AND FURNISHERS
· 1234567890 ·

This Series will register for color printing with Quaint Open on opposite page

QUAINT OPEN

PATENTED

48 POINT

4 A \$4 00

GRAND · JOKER

36 POINT

6 A \$3 40

EVENING · SERMON

24 POINT

8 A \$2 90

THIRD · NATIONAL · BANK

18 POINT

10 A \$2 25

STRONG · AND · HEARTY
HISTORIC · CHESTNUT · SOCIETY

12 POINT

14 A \$1 90

REVIEWING GRAND PARADE
PHILADELPHIA · VETERAN · ASSOCIATION

10 POINT

20 A \$1 90

GOLD · AND · SILVER
RICH DIAMOND FIELDS
: 12345678 :

8 POINT

24 A \$1 90

HUMFTE · & · DUMFTE
DEALERS AND FURNISHERS
· 1234567890 ·

This Series will register for color printing with Quaint Series on opposite page

VIRILE SERIES

PATENTED

60 POINT

4 A 6 a \$7 50

OPENING Season

48 POINT

6 A 8 a \$6 50

Bountiful HARVESTS

36 POINT

6 A 10 a \$6 00

SLAUGHTERED Buffaloes

30 POINT

8 A 12 a \$5 50

Mexican VOLCANIC Eruptions

24 POINT

10 A 16 a \$4 00

BENEVOLENT GATHERINGS
Honorable and Charitable Associations

18 POINT

12 A 20 a \$3 50

STRONG WIND
Natural Flower Odors

1 2 3 4 5 6 7 8

12 POINT

16 A 30 a \$3 00

PLEASING PRODUCTS
Designed for Modern Printers

1 2 3 4 5 6 7 8 9 0

This Series will register for color printing with Virile Open on opposite page

VIRILE OPEN

PATENTED

60 POINT

4A 6a \$7 50

OPENING Season

48 POINT

6A 8a \$6 50

Bountiful HARVESTS

36 POINT

6A 10a \$6 00

SLAUGHTERED Buffaloes

30 POINT

8A 12a \$5 50

Mexican VOLCANIC Eruptions

24 POINT

10A 16a \$4 00

BENEVOLENT GATHERINGS
Honorable and Charitable Associations

18 POINT

12A 20a \$3 50

STRONG WIND
Natural Flower Odors
12345678

12 POINT

16A 30a \$3 00

PLEASING PRODUCTS
Designed for Modern Printers
1234567890

This Series will register for color printing with Virile Series on opposite page

ERRATICK SERIES

PATENTED

48 POINT

4A 5a \$7 50

SUPERB
Style 4 Boats

42 POINT

4A 6a \$6 00

Expert SONG 5

30 POINT

6A 8a \$5 50

GRAND 2 Bargains

24 POINT

8A 12a \$4 00

BARTON
Historians 2

18 POINT

10A 18a \$3 50

MEXICANS
Grand 9 Sports

12 POINT

14A 24a \$3 00

ACTORS FANCY
Designed 8 Engraved

10 POINT

16A 32a \$2 75

ELEGANT ROSES
That Bloom in Spring 12

8 POINT

20A 32a \$2 50

MONROE DOCTRINE
Uncle Samuel Laying Plans 7

6 POINT

20A 40a \$2 25

BOULEVARDS SPRINKLED
German Band 29 Exquisite Melodies

This Series will register for color printing with Erratick Outline on opposite page

ERRATICK OUTLINE

PATENTED

48 POINT

4A 5a \$7 50

SUPERB
Style 4 Boats

42 POINT

4A 6a \$6 00

Expert SONG 5

30 POINT

6A 8a \$5 50

GRAND 2 Bargains

24 POINT

8A 12a \$4 00

BARTON
Historians 2

18 POINT

10A 18a \$3 50

MEXICANS
Grand 9 Sports

12 POINT

14A 24a \$3 00

ACTORS FANCY
Designed & Engraved

10 POINT

16A 32a \$2 75

ELEGANT ROSES
That Bloom in Spring 12

8 POINT

20A 32a \$2 50

MONROE DOCTRINE
Uncle Samuel Laying Plans ?

6 POINT

20A 40a \$2 25

BOULEVARDS SPRINKLED
German Band 29 Exquisite Melodies

This Series will register for color printing with Erratick Series on opposite page

LIVERMORE SERIES

PATENTED

60 POINT

3 A 4a \$8 25

Denouncement

48 POINT

3 A 6a \$6 25

Famous Workmen

36 POINT

4 A 10a \$5 25

Determined Advertiser

30 POINT

5 A 12a \$4 75

Reward Honest Merchants

24 POINT

6 A 18a \$4 25

*Brave Chaplain
Receives Medal*

18 POINT

9 A 28a \$3 75

*Wonderful Cavalcade
Marching Homeward*

12 POINT

15 A 50a \$3 25

*Youthful Juveniles Rehearse
Dramatic Elocution Admired*

10 POINT

15 A 55a \$3 00

*Patriotic Orators Arouse Natives
Enthusiastic Countrymen Prepare
Great Midsummer Demonstration*

8 POINT

15 A 55a \$2 75

*Sensational News of Great Victories
and Military Achievements Eagerly
Devoured by all Patriotic Admirers*

6 POINT

15 A 60a \$2 50

*Conservatives and Radicals Join Hands
for the Sole Purpose of Introducing Peace
on Conditions Acceptable to both Countries*

1 2 3 4 5 6 7 8 9 0

1 2 3 4 5 6 7 8 9 0

The five larger sizes will register for color printing with Livermore Outline on opposite page

LIVERMORE OUTLINE

PATENTED

60 POINT

3 A 4a \$8 25

Denouncement

48 POINT

3 A 6a \$6 25

Famous Workmen

36 POINT

4 A 10a \$5 25

*Remunerated
Determined Advertiser*

30 POINT

5 A 12a \$4 75

*Generous Patrons
Reward Honest Merchants*

24 POINT

6 A 18a \$4 25

*Meritorious Investigation
Scientific Explorations Postponed
1 2 3 4 5 6 7 8 9 0**The above sizes will register for color printing with the same sizes of Livermore Series on opposite page*

EPITAPH AND EPITAPH OPEN

3 A \$6 00

48 POINT

3 A \$6 00

MACHINERY

5 A \$4 25

36 POINT

5 A \$4 25

LADS LEND BIKE

7 A \$3 25

24 POINT

7 A \$3 25

**NORTHSHORE
HUNTS LEGAL NOTICE**

18 POINT

9 A \$2 50

**EXCHANGING PRODUCE
JOINT DEBATE ^{AND} FALSE TALKS**

12 POINT

14 A \$2 25

**PERIODICAL CIRCULATIONS
WHISTLING HURRICANES TURNING PYRAMIDS**

1 2 3 4 5 6 7 8 9 0

The 24, 30 and 48 Point sizes of this Series will register for color printing

See page 433 for specimen
in colors

EREBUS AND HADES
SOLID " SHADED

PATENTED

60 POINT

EITHER SERIES 4 A \$5 75

MANY COLORS

MANY COLORS

48 POINT

EITHER SERIES 5 A \$4 50

HANDSOME FACE

HANDSOME FACE

36 POINT

EITHER SERIES 6 A \$3 50

HIGHEST MONUMENTS

HIGHEST MONUMENTS

24 POINT

EITHER SERIES 8 A \$2 25

ROMANESQUE MUSICAL CADENCE

ROMANESQUE MUSICAL CADENCE

1234567890

1234567890

These Series work in combination in colors with beautiful effect. In ordering, remember that two Series are shown on this page—the Erebus (heavy-face) and the Hades (shaded face)

BINNER SERIES

72 POINT

4A 5a \$17 00

BRICK
Blue Golf
Shoes

60 POINT

4A 5a \$12 25

CINDER
Path Road
Bicycle

BINNER SERIES

54 POINT

4A 5a \$10 25

**BEST HIGH
Price Onions**

48 POINT

4A 5a \$7 75

**INDIAN MEAL
Flour and Flams**

36 POINT

5A 8a \$5 50

**COMIC SKETCH
With Lead Pencils
Not Traced**

BINNER SERIES

30 POINT

8 A 9 a \$5 00

**MAGNIFICENT
Harbor and River View**

24 POINT

8 A 10 a \$4 50

**RADICAL CHANGES
During Presidential Election**

18 POINT

10 A 16 a \$4 00

**BRITISH NORTH AMERICA
Raising Numerous Valuable Equines
Thoroughly Acclimated**

12 POINT

16 A 20 a \$3 25

**GRAND HOLIDAY
Printers and Editorial
Fabricators**

10 POINT

20 A 26 a \$3 00

**TWILIGHT HUSH
Hence the Shadows Growing
Unsurpassable**

8 POINT

22 A 30 a \$2 75

**WORCESTER CELEBRATION
Attended by Small Army from Ohio
and California, with Bright Bunting**

1 2 3 4 5 6 7 8 9 0

6 POINT

24 A 36 a \$2 50

**FACE OF LATE TYPOGRAPHY
Handsome, Durable and Comprehensive the
Fervor of its Reception Should be Unmixed**

1 2 3 4 5 6 7 8 9 0

BINNER OPEN

72 POINT

4A 5a \$17 00

Per SON

60 POINT

4A 5a \$12 25

BEN Hume

48 POINT

4A 5a \$7 75

Canary BIRDS

36 POINT

5A 8a \$5 50

SINGLE Harness

24 POINT

8A 10a \$4 50

Morro Castle DISFIGURED

18 POINT

10A 16a \$4 00

HUMOROUS
Clown's Answer
1 2 3 4 5

12 POINT

16A 20a \$3 25

MARCH FOURTH
President United Sons
Veterans and Fighters
6 7 8 9 0 \$

CONTOUR No 1

48 POINT

4A 8a \$6 80

Black HORSE

36 POINT

5A 10a \$6 90

UNITED Service

28 POINT

6A 12a \$5 15

Carmine BRUSHES

24 POINT

8A 16a \$5 00

SURGICAL Operations

20 POINT

10A 20a \$5 00

CONSERVATORIES
Musical Question Debated

16 POINT

10A 20a \$3 45

ENGAGED
Choice Resort
123456

12 POINT

16A 32a \$3 25

CONSIDERED
National Movement
1234567

CONTOUR No 6

72 POINT

3 A \$5 40

ENUMERATES

60 POINT

3 A \$3 75

BOND 45 MARK

48 POINT

4 A \$3 20

MODERN HEROES

40 POINT

5 A \$2 70

FAMOUS 68 GARDEN

32 POINT

8 A \$2 75

BEAUTIFUL

24 POINT

12 A \$2 25

ADVANCEMENT

18 POINT

18 A \$2 10

BROKERS REPORTS
RECEIVED 49

12 POINT

32 A \$2 00

PERFORMERS BANQUETED
875 GORGEOUSLY

CONTOUR No 4

12

72 POINT

3 A 5 a \$11 95

Hire MEN

80 POINT

3 A 5 a \$9 45

END Games

48 POINT

4 A 8 a \$8 20

Defend RIGHT

40 POINT

4 A 8 a \$6 00

STORM Damaged

32 POINT

5 A 10 a \$4 90

Prominent FIREMEN

28 POINT

6 A 12 a \$4 00

REPORTER Promenading

1234567890

CONTOUR No 7

72 POINT

3 A 6 a \$7 85

Botanical RECORD

60 POINT

3 A 6 a \$5 90

COURSES Maintained

44 POINT

4 A 8 a \$4 40

POSITION SECURED
National Finance Reporter

32 POINT

5 A 10 a \$3 35

POPULAR MOVEMENT
Calisthenic Societies Organized
1234567890

CONTOUR No 2

48 POINT

3 A \$7 40

MOTIVES

36 POINT

4 A \$3 30

BIRD 8 CLUB

24 POINT

6 A \$1 00

NOTICES
SENT

18 POINT

8 A \$1 65

NUMEROUS
WOMEN

CONTOUR No 3

36 POINT

3 A \$5 75

RINGS

24 POINT

6 A \$4 25

NOT 4 BIG

18 POINT

6 A \$2 25

BRING MORE
PRODUCE

CONTOUR No 5

48 POINT

3 A \$5 40

BEACON

36 POINT

4 A \$4 00

DECORATE

24 POINT

6 A \$2 35

FOREIGN RACES
65 HORSE

GRAPHIC SERIES

28 POINT

5 A \$3 50

MALDEN GRAPES

24 POINT

6 A \$3 00

FRUITS AND CREAM

22 POINT

7 A \$2 50

TWELVE PEOPLE LOST

18 POINT

8 A \$2 25

BOSTONS SUBWAY CALAMITY
1 2 3 4 5 6 7 8 9 0

LAFAYETTE SERIES

PATENTED

72 POINT

4A 5a \$9 50

STRONG Drinker

60 POINT

4A 6a \$7 50

Morning SUNSHINE

54 POINT

4A 6a \$7 00

HANDSOME Butterfly

48 POINT

6A 8a \$7 00

Watchman EXCELLENT

42 POINT

6A 9a \$6 25

DARK Nights

36 POINT

8A 10a \$5 75

NUDE Figures

30 POINT

9A 12a \$5 00

Lucrative PLACES

24 POINT

10A 14a \$4 00

Favorable PASTIME

18 POINT

12A 18a \$3 25

IMPETUOUS Philanthropy

12 POINT

20A 30a \$3 00

CORRESPONDING 54 Predicaments

JEFFERSON SERIES

PATENTED

60 POINT

4A 5a \$11 00

POLAR Perils

54 POINT

4A 5a \$8 50

Land POINTER

48 POINT

4A 6a \$7 75

TEN Cat

42 POINT

4A 6a \$6 25

Fat BOYS

36 POINT

5A 7a \$5 75

Gold MINE

30 POINT

6A 8a \$4 75

OCEAN Sailor

24 POINT

8A 10a \$4 50

SKATING Drills

18 POINT

10A 14a \$3 25

Famous PUBLICATION

12 POINT

16A 24a \$3 00

CONGRESSIONAL NOTES
Bright Entertaining Gentlemen

10 POINT

20A 28a \$2 75

MARINERS DELIGHTED
When Land is Sighted after Six Months

8 POINT

24A 32a \$2 50

CHARMING AND HANDSOME MAID
Exciting Football Games on the Pastime Grounds

6 POINT

26A 38a \$2 25

PROPOSED NEW AMENDMENTS TO THE
Constitution of United States for Emancipation of Base Ball Slaves

1 2 3 4 5 6 7 8 9 0

WASHINGTON SERIES

PATENTED

60 POINT

4A 5a \$15 00

RICH Man

54 POINT

4A 5a \$10 50

Dear GAME

48 POINT

4A 5a \$10 00

FRIED Grabs

42 POINT

4A 6a \$7 25

Best NEW Dish

36 POINT

5A 8a \$6 75

TIN Pan

30 POINT

6A 8a \$5 25

Flat RIMS

24 POINT

8A 10a \$4 50

Daily RIDES

18 POINT

9A 13a \$3 50

NOVEL Whalers

12 POINT

12A 18a \$3 00

FISHERMAIDEN
Handsome Companion

10 POINT

16A 22a \$2 75

SAILING EXCURSION
Midnight Trip Advertised

8 POINT

18A 24a \$2 50

ENCAMPMENT CUISINE
Palatable Dainties Served Gratis

6 POINT

22A 32a \$2 25

DELIGHTFUL EVENING PASTIME
Repairing Fishing and Gunning Equipment

1 2 3 4 5 6 7 8 9 0

1 2 3 4 5 6 7 8 9 0

QUAINT ROMAN No 2

48 POINT

4 A 5 a \$11 00

Great RISE

36 POINT

4 A 6 a \$8 50

ANCIENT
Nubian Builder

24 POINT

6 A 8 a \$5 00

HISTORIANS
Charming and Reliable

18 POINT

8 A 10 a \$4 50

MODERN CUSTOMS
Inaugurated by Academician

12 POINT

14 A 16 a \$3 25

ENDORSEMENT
Rejoicing Projectors
I 2 3 4 5 6 7

10 POINT

14 A 18 a \$3 00

MEXICAN EDITION
Original Fashion Designs
I 2 3 4 5 6 7 8 9 0

LIPPINCOTT SERIES

PATENTED

60 POINT

4A 6a \$9 00

BRISK Dames

48 POINT

4A 7a \$6 50

Rare MUSIC Box

36 POINT

6A 8a \$5 00

Aspirants EXAMINED

30 POINT

7A 10a \$4 25

Quaint HAMBURG Stones

24 POINT

10A 15a \$3 75

URCHINS Grand Display

18 POINT

12A 18a \$3 25

ANTIQUATED Miniature Camera

12 POINT

22A 35a \$3 00

PARISIAN HEADREST Beautiful Result Obtained

10 POINT

28A 40a \$2 75

EVENING PROMENADES Invigorating and Rejuvenating

8 POINT

30A 50a \$2 50

AMATEUR KODAK SOCIETY Picturesque Moonbeams Reproduced

6 POINT

35A 52a \$2 25

UNIVERSAL ART EXHIBITION Highly Complimentary Marine Photography

1 2 3 4 5 6 7 8 9 0

1 2 3 4 5 6 7 8 9 0

DUERER SERIES

PATENTED

—12—

72 POINT

3 A 5a \$10 00

Golden HOURS

60 POINT

3 A 6a \$9 00

HOUSE Burning

48 POINT

3 A 4a \$6 00

Prominent ACTORS

36 POINT

5 A 7a \$4 75

GRANITE
Monuments

24 POINT

8 A 11a \$4 00

CHRISTMAS
Holiday Presents

18 POINT

11 A 16a \$3 25

IMPROVEMENTS
Neatness and Dispatch
Promptness 35

12 POINT

18 A 24a \$3 00

HONORED VISITORS
Elaborate Receptions Tendered
Refreshing \$614

RUBENS SERIES

PATENTED

72 POINT

5 A 6 a \$10 25

SUMMER Fashions

60 POINT

4 A 7 a \$7 50

Extraordinary DISPLAY

54 POINT

6 A 8 a \$6 75

STUMP ORATORS
Debating Silver Question

48 POINT

6 A 8 a \$6 00

EVENING CONCERT
Original Burlesque Company

RUBENS SERIES

PATENTED

42 POINT

7 A 10 a \$5 50

GENTLEMEN ESTABLISH
Modern Reform Municipal League

36 POINT

8 A 12 a \$5 00

MONUMENT ASSOCIATION
Contributions from Patriotic Volunteers

30 POINT

10 A 14 a \$4 50

ORGANIZED BANKING COMPANIES
Autocratic Millionaires Purchasing Securities

24 POINT

12 A 18 a \$4 25

PURLOINED KISSES IN TUNNELS
Compressed Sweetness Between Lightning Fleetness

18 POINT

12 A 24 a \$3 25

DURABLE AND NEAT
Reversible Seamless Overcoat
Practical 517 Gift

12 POINT

22 A 36 a \$3 00

MUSCULAR ENDURANCE
Entertainments In Gymnastic Contests
Athletic 298 Game

TAYLOR GOTHIC

48 POINT

4 A 5 a \$7 75

**PLEASING
Newest Master**

36 POINT

5 A 8 a \$5 50

**EXCURSIONS
Returning Delegates
Butter Cakes**

24 POINT

10 A 15 a \$4 50

**DARKEST
African Mines
Studying**

18 POINT

12 A 20 a \$4 00

**INDUSTRIAL
Workers Gathered
Destructions**

12 POINT

16 A 25 a \$3 25

**YOUNG HEROES
Purchase Made Christmas
1 2 3 4 5 6 7**

10 POINT

20 A 30 a \$3 00

**PRINTING MATERIAL
Handsome Durable and Extensive
1 2 3 4 5 6 7 8 9 0**

FLORENTINE HEAVYFACE

48 POINT

4 A 5 a 87 75

**SOUNDING
Army 9 Packs**

36 POINT

5 A 8 a 85 50

**PORTSMOUTH
Cruiser 83 Station**

24 POINT

8 A 10 a 84 50

**REGULAR SOLDIERS
Gentlemanly 25 Characters**

18 POINT

10 A 16 a 84 00

**AMERICAN
Type 8 Founder**

12 POINT

16 A 20 a 83 25

**TEXAS RANGERS
Marching to Quincy 8**

10 POINT

20 A 26 a 83 00

**HUMBUG OINTMENT
Efficacious 9 Medicaments**

8 POINT

22 A 30 a 82 75

**DELIGHTFUL PAGEANTS
Viewed from a Hundred Stands 24**

6 POINT

24 A 36 a 82 50

**ENDURE EASTERN HARDSHIPS
Mountain Climbers 34 were Exhausted**

5 POINT ON 6 POINT

24 A 36 a 82 50

**BASKING IN WINTERS CHILLY WEATHER
Enjoying the Lavishly-Stocked Larders 234179**

EASTMAN SERIES

72 POINT

3 A 5 a \$10 65

MINES
Enhanced

60 POINT

4 A 5 a \$9 90

DREAMS
Imagination

48 POINT

4 A 6 a \$6 95

FICTION
Ghost Stories

EASTMAN SERIES

36 POINT

5 A 8 a \$5 50

ATHLETIC Olympian Games

30 POINT

6 A 9 a \$5 00

GYMNASTICS Interesting Tournament

24 POINT

8 A 10 a \$4 00

CHAMPION PITCHER Rowing and Cricket Matches

18 POINT

10 A 16 a \$3 25

PREVIOUS Records Broken

10 POINT

20 A 26 a \$2 75

SHARP FIELDING Defeated the Visiting Team

8 POINT

22 A 30 a \$2 50

AMERICAN SPORTSMEN Receive an Ovation in England 1 2 3 4 5 6 7 8 9 0

12 POINT

16 A 20 a \$3 00

INTERNATIONAL Amateur Bicycle Race

9 POINT

20 A 40 a \$2 55

SUBURBAN RIDERS Demand Tollgates Abolished

6 POINT

24 A 48 a \$2 30

GOLF AND HOCKEY GROUNDS Opening Games on the Splendid Links Fine Contests Expected 1 2 3 4 5 6 7 8 9 0

HOUGHTON SERIES

PATENTED

60 POINT

3 A 4 a \$11 90

Refreshment

48 POINT

3 A 5 a \$9 25

Strong Acrobat

36 POINT

3 A 7 a \$7 50

Interesting Farcical

24 POINT

4 A 10 a \$4 50

Aeronauts Descend Quickly

FERDINAND SERIES

PATENTED

60 POINT

3 A 5 a \$9 85

Grand Comedy

48 POINT

3 A 8 a \$7 35

Froliesome Players

36 POINT

4 A 10 a \$5 30

Convulsed with Laughter

SAMOA SERIES

PATENTED

48 POINT

3A 5a \$6 50

GRAND Trade

12 POINT

25 A 32 a \$3 00

24 POINT

8A 10a \$4 00

THERE ARE VERY FEW
Type-faces which show

CATCHES

to better advantage in a
page to which it is de-
sired to give a character

Many
Eyes

of striking oddity. The
letters are unique, clear

The

18 POINT

11 A 16 a \$3 25

and strong. Notice one of

THIS
LETTER

the peculiar features as
told at bottom of page

Sure to Please and Attract by Oddity

36 POINT

4A 6a \$5 00

Fantastic WHIMS

1 2 3 4 5 6 7 8 9 0 The and G

One of the peculiar features of this series is, that the lower-case letters b d h m n p q and y can be used to represent q p y w d b and h; capital M makes W; figure 7 makes L, and figure 0 makes o, by merely inverting them—an important item to the printer when short of "sorts." The letters line both ways. Logotypes furnished with each size.

AMERICAN OLD STYLE No 3

60 POINT

3 A 8 a \$10 00

PRINTERS
Artistic Form

48 POINT

4 A 8 a \$7 00

RECORDERS
Modern Huntress

36 POINT

6 A 10 a \$5 50

THANKS
Find Seat

30 POINT

8 A 12 a \$4 70

MUSICAL
Sacred Echo

24 POINT

10 A 15 a \$4 00

ANTIQUATED
Machine Operator

18 POINT

12 A 18 a \$3 50

CHICAGO DELEGATE
Honoring European History
American Contractor

CASLON CONDENSED

60 POINT

3 A 5 a \$9 00

DRUGS Known

48 POINT

3 A 5 a \$5 50

Northern HUNTERS

36 POINT

4 A 8 a \$5 00

**UPHOLSTERER
Engraved 56 Furniture**

30 POINT

5 A 10 a \$4 50

**NOTICES PRINTED
Removed Handsome Gardens**

24 POINT

6 A 12 a \$3 50

**BORDERING
Flower 43 Houses**

18 POINT

8 A 16 a \$3 00

**DEMONSTRATIONS
Remarkable Consignment
Performances**

IROQUOIS SERIES

60 POINT

3 A 4 a \$12 00

**OPEN
Scandal**

48 POINT

3 A 4 a \$8 00

**PUBLIC
Cash Lost**

36 POINT

3 A 6 a \$6 50

**→ HOUND ←
Rough Antics**

30 POINT

4 A 8 a \$5 50

**ENTOMBED
Staunch Heroes**

IROQUOIS SERIES

24 POINT

5 A 10 a \$4 50

→ **GUARDIANS** ←

Defending Entrance
Swell Regiments

18 POINT

6 A 12 a \$3 30

SMART LEADER

Promotes Valiant Soldier
Daring Shots

12 POINT

10 A 18 a \$2 40

PATRIOTIC DEMONSTRATION

Eminent Speakers Praise Volunteers
Greatest Enthusiasm

10 POINT

14 A 20 a \$2 35

TRIUMPHANT TROOPS ARRIVE

Beautiful Maidens Welcome the Conquerors
Extensive Preparations

8 POINT

16 A 30 a \$2 10

PRELIMINARY PEACE NEGOTIATIONS OPENED

Interference of Foreign Diplomats Emphatically Rejected
Territorial Expansion and Indemnity

6 POINT

20 A 40 a \$2 40

REBUKE ADMINISTERED TO COUNTRY JOURNALS

Indiscreet Reporters were Summarily Removed from Headquarters
Transports Arrive with Convalescents

1234567890

IROQUOIS CONDENSED

60 POINT

3 A 5 a \$9 00

BORNEO
East Indies

48 POINT

4 A 6 a \$6 50

CLOISTER
Lake Superior

36 POINT

5 A 8 a \$4 90

HISTORICAL
Southern Metropolis

30 POINT

6 A 9 a \$4 25

IMPROVEMENTS
Mechanical Department

IROQUOIS CONDENSED

24 POINT

8 A 12 n \$3 75

AMERICAN CONSULS
Diplomatic Services Rendered
Mercantile Gains

18 POINT

10 A 16 n \$3 00

OCEANIC MINING COMPANY
Natural Resources Become Exhausted
Alchemistical Schemes

12 POINT

12 A 20 n \$2 75

→ DISASTROUS RAILROAD COLLISIONS ←
Returning Excursionists Delayed Through Wrecked Trains
Several Miraculous Escapes

10 POINT

15 A 25 n \$2 50

POLICE OFFICERS CAPTURE CHINESE HIGHBINDERS
Celestial Secret Societies Banded Together for Murder and Arson
Authorities Make Startling Discoveries

8 POINT

20 A 30 n \$2 25

MOUNTAINOUS SUMMER RESORT FOR DYSPEPTIC BAGHELORS
Unsurpassed Facilities for Recreation without Disturbance by Chattering Society Girls
Prominent Specialists Attend Nervous Derangements

6 POINT

25 A 35 n \$2 00

→ SAUNTERINGS AND REMARKABLE ADVENTURES IN PICTURESQUE PALESTINE ←
Conclusive Evidence of Turkish Mismanagement Found Everywhere Among Ruins of Ancient Prosperity
Latest Researches Disclose Buildings of Architectural Beauty and Splendor

1234567890

JENSON SERIES

PATENTED

48 POINT

4 A 6 a 87 40

Skating TOURS

36 POINT

5 A 8 a 86 15

LARGE Steamboat

30 POINT

7 A 10 a 85 20

Dilapidated RAILROAD

24 POINT

10 A 16 a 84 60

DISTRACTION and Worriment

18 POINT

12 A 18 a 83 85

Indústrious Workers INTERRUPTED

14 POINT

14 A 20 a 83 05

FASCINATING Actress Entertains Ladies

12 POINT

16 A 25 a 82 85

Public Information Bureau DAILY PATRONIZED

1 2 3 4 5 6 7 8 9 0

TYPO SERIES

PATENTED

60 POINT

3 A 4 a \$7 00

CRADLE Nonsense

48 POINT

4 A 6 a \$5 25

Grenadines LAUNDRIED

36 POINT

5 A 7 a \$4 70

30 POINT

6 A 9 a \$3 55

FISH Market LARGE Cushion

24 POINT

8 A 10 a \$2 85

18 POINT

10 A 14 a \$2 40

Broken 26 PLEDGE Hunting 58 FRANCHISE

MANSFIELD SERIES

48 POINT

3 A 6 a \$8 50

Bright Diamonds

36 POINT

4 A 8 a \$6 00

24 POINT

6 A 12 a \$4 00

Canadians Representatives

18 POINT

8 A 16 a \$3 50

12 POINT

10 A 20 a \$3 00

Studios Mechanics Improved Perfecting Presses
Hard 47 Work Splendid 85 Machine

ELBERON No 2

36 POINT

4 A 6 a \$8 80

GREAT Romans

24 POINT

6 A 10 a \$6 70

Unruly Child TEACHER

18 POINT

8 A 14 a \$5 25

DARK CLOTH
Mark 85 Price

12 POINT

10 A 18 a \$3 90

IMPROVED PRESS
Highly 74 Warranted

KOSTER SERIES

PATENTED

24 POINT with 48 Point Initials

3 A 8 A 12 a \$9 65

LIVELY KID

Omnivorous Tendencies

18 POINT with 36 Point Initial

4 A 10 A 16 a \$7 45

RUSTIC WORKER

Water-Pails and Coal-Shovels

12 POINT with 24 Point Initials

6 A 14 A 22 a \$5 30

SOMNOLENT & Co

Fabricators of Air-Castles and Hammocks

1234567890

CHILDS SERIES

PATENTED

60 POINT

3 A 5 a \$10 65

OUR Guard

48 POINT

4 A 6 a \$8 35

Hold the FORT

36 POINT

5 A 8 a \$8 30

GRAND Manœuvre

30 POINT

6 A 9 a \$5 15

STOUT
Conscripts

24 POINT

8 A 12 a \$4 50

DARING
Skirmishers

18 POINT

12 A 18 a \$4 10

AMAZONS
Robust Warriors
123456

12 POINT

20 A 30 a \$3 80

UNBLUSHING
Regimental Daughters
12345678

MORTISED INITIAL LETTERS C F L T ACCOMPANY EACH FONT

DYNAMO SERIES

PATENTED

48 POINT

3 A 4 a \$4 55

PENSIONS Received

36 POINT

4 A 6 a \$3 80

Government EXPANSION

24 POINT

8 A 10 a \$3 00

RAILROAD EXCURSION
Around the Continents Gratuitously

18 POINT

10 A 14 a \$2 45

INDUSTRIAL
Proceeds Distributed
12345678

12 POINT

16 A 25 a \$2 25

TELEGRAPHING
Messages Between Gallants
12345678

WALTON SERIES

36 POINT

4 A 8 a \$4 15

Handsome 6 SERIES Furnished

30 POINT

5 A 10 a \$3 65

Magnificent Christmas PRODUCTION

24 POINT

6 A 12 a \$3 15

SECOND 435
Dividends Purchased

18 POINT

8 A 16 a \$2 85

PROBLEM 578
Remarkable Performance

LONGFELLOW SERIES

72 POINT

3 A 6a \$12 00

Broken Carriage

60 POINT

4 A 9a \$11 00

Educate the Minor

54 POINT

4 A 8a \$10 00

Theorists

48 POINT

4 A 10a \$9 00

Marriages

42 POINT

4 A 10a \$8 00

Researches

36 POINT

4 A 12a \$7 00

Enchantment

30 POINT

5 A 14a \$6 00

Warlike Errand

24 POINT

7 A 16a \$5 00

Advanced Thinkers

18 POINT

9 A 22a \$4 50

Removing the Wreckage

12 POINT

14 A 40a \$4 00

Expedition Starting for Iceland

10 POINT

14 A 40a \$3 50

Surveyors Dispel Senseless Theories
1234567890

8 POINT

14 A 40a \$3 00

Stupendous Undertakings Accomplished
1234567890

DOUGLAS SERIES

48 POINT

3 A 6 a \$6 25

RENT Receipts

42 POINT

3 A 6 a \$5 00

Gostume DESIGN

36 POINT

4 A 8 a \$4 90

NURSE 85 Granted

30 POINT

6 A 12 a \$4 45

FOREIGN STONE
Assortment Monuments

24 POINT

8 A 16 a \$4 30

SUN FISH
Large Dealer

18 POINT

10 A 20 a \$3 30

AMBITIOUS
National Guards

12 POINT

12 A 24 a \$2 10

GOLD SHIPMENT
Enterprising Prospector
1234567890

10 POINT

18 A 36 a \$2 40

DELIGHTFUL MUSIG
Egyptian Selections Rendered
1234567890

LINCOLN SERIES

60 POINT

3 A 6 a \$7 25

NOVEL Counters

48 POINT

4 A 9 a \$6 00

Durable MACHINES

42 POINT

4 A 8 a \$5 00

THEATRE Frequenter

36 POINT

5 A 10 a \$4 75

NEW BAIT
Small Frogs

30 POINT

6 A 12 a \$3 75

GOMIG SONG
Glancy's Goats

24 POINT

8 A 16 a \$3 50

BOSTON MAIDS
Liberal Delegates

18 POINT

10 A 20 a \$2 75

BURLESQUE SHOW
Joyful Voices Rising

12 POINT

12 A 24 a \$2 25

EXCEPTIONAL ADVANTAGE
Granted to Summer Customers
1234567890

10 POINT

20 A 40 a \$2 00

DIRECT TELEGRAPHIC CONNECTION
Reviewing Descriptive News of Spain
1234567890

JOHNSON SERIES

PATENTED

60 POINT

3 A 5 a \$9 60

Grand Jaunts

48 POINT

3 A 6 a \$7 60

Beautiful Scenes

36 POINT

4 A 8 a \$6 20

Gorgeous Landscape

30 POINT

5 A 10 a \$5 75

Crossing the Mountains

24 POINT

6 A 12 a \$5 05

Tourists Enjoying the Sport

18 POINT

8 A 16 a \$4 35

Running Up Hills and Down Valleys

1234567890

ART GOTHIC

PATENTED

72 POINT

3A 5a \$10 00

Reform School

60 POINT

4A 5a \$9 20

Fraternal Artists

48 POINT

4A 5a \$8 50

Carnival Excursions

36 POINT

6A 8a \$5 00

Merchandise Undervalued

24 POINT

8A 10a \$4 00

Indisputable Fence-rail Philosopher

18 POINT

12A 16a \$3 00

Unfounded Aristocracy Degenerating Hypocrites

12 POINT

14A 20a \$3 00

Merry Midway Plaisance Girl

1234567890

10 POINT

18A 28a \$2 75

Proposed Aerial Grips Postponed

1234567890

COLUMBIAN SERIES

PATENTED

60 POINT

3 A 5a \$7 95

Riverside Tramways

48 POINT

4 A 6a \$6 70

Advantageous Movement

42 POINT

5 A 10a \$6 00

Portraying Domestic Industry

30 POINT

6 A 16a \$5 10

Pictures of the Gigantic
Columbian Exposition Viewed Hourly

24 POINT

8 A 28a \$4 40

Celebrating the Landing of Columbus
Display of American and European Handicraft

1234567890

WEBSTER SERIES

36 POINT

3 A 6 a \$5 00

ENGINEERING
Mechanical Lessons

24 POINT

6 A 10 a \$4 00

GRAND BANQUET
Visiting European Statesmen

18 POINT

8 A 14 a \$3 25

BUILDER AND MECHANIC
Constructors of Famous Modern Dwellings
Satisfaction Guaranteed

12 POINT

12 A 22 a \$3 00

WONDERFUL ELECTRIC MACHINERY
Examinations by the General Public Particularly Desired
Exhibition at Manufactory

10 POINT

16 A 22 a \$2 75

BEAUTIFUL HOLIDAY PRESENTS OFFERED
Customers are Respectfully Requested to Examine these Articles

1234567890

UNIQUE CELTIC

PATENTED

36 POINT

4 A 6 a \$6 20

Famous SIGNS

30 POINT

6 A 8 a \$5 35

BREAD Producers

24 POINT

7 A 10 a \$4 05

Inconsistent REMARKS

18 POINT

10 A 14 a \$3 60

Railroad FREIGHT Contracts

14 POINT

12 A 18 a \$3 25

SUBLIME SHOWING
Annual Parisian Trimming Display

12 POINT

15 A 22 a \$3 00

UNBIASED
Decision Rendered

10 POINT

18 A 28 a \$2 90

SEMPER IDEM
Sunshine after Storm

8 POINT

20 A 32 a \$2 60

CONNOISSEURS
Spacious Pothouse Patrons
12345678

6 POINT

22 A 35 a \$2 50

MINERAL DEPOSITS
Auriferous Dumping Grounds
1234567890

UNIQUE CELTIC CONDENSED

36 POINT

4 A 6 a \$4 25

Enthusiastic HORDES

30 POINT

6 A 8 a \$3 75

SPORTIVE Demonstration

24 POINT

8 A 10 a \$3 25

WINSOME VIRGINS
Humorist Banishing Melancholy

18 POINT

12 A 16 a \$3 00

ORATORICAL REFORMERS
Smockfrocked Blatherskites Gesticulating

12 POINT

18 A 30 a \$2 75

DARING SEARCH
Returned Seamen Rejoicing
after a Perilous Expedition

10 POINT

20 A 34 a \$2 50

FOREIGN VIEWS
Memorable Scenes Reproduced
by the New Electric Verascope

8 POINT

25 A 38 a \$2 25

MACHINES PERFECTED
Labor-Saving Apparatus Guaranteed
Complete with all the Latest Devices
1234567890

6 POINT

30 A 45 a \$2 00

EXPEDITION TO WONDERLAND
Language Falls to Describe this Wonderful Isle
which is Situated in the North Atlantic Ocean
1234567890

ALPINE SERIES

36 POINT

4A 8a \$5 80

Southern Light Movements

24 POINT

6A 12a \$4 35

Honesty Eliminated Through Perversity
Governing Universal Educational Course

18 POINT

8A 16a \$3 65

Enthusiastic Conventions
Bostonian 53 Institutions

12 POINT

10A 20a \$2 35

Millionaires Charitable Association
Established in 1874 San Francisco
Graduated Nurses in the Hospitals

HERMES SERIES

36 POINT

6A 10a \$5 50

DECLINE OF OLD ROME
Palace of the Senators in Ruins

24 POINT

10A 15a \$4 50

HIGH ADMISSION TICKETS
Scathing Denunciations Really Deserved

18 POINT

12A 18a \$3 25

DIABOLICAL PLOT
Exposed by Mere Accident
Secure Present 34

12 POINT

18A 24a \$3 00

SURGICAL OPERATIONS
Performed With Neatness and Dispatch
Home Knowledge 674

EUCLID SERIES

48 POINT with 72 Point Initials

3A 3A 5a \$18 80

Real DAM

36 POINT with 60 Point Initials

3A 4A 6a \$13 30

HOME Parties

30 POINT with 48 Point Initials

3A 5A 8a \$11 30

Eastern COUNTY

24 POINT with 36 Point Initials 3A 6A 10a \$7 60

Kind Boy
FACE 82

18 POINT with 30 Point Initials 3A 8A 14a \$6 75

North Shores
HOMES 54

12 POINT with 24 Point Initials 4A 10A 18a \$4 75

Eastern Convention
Rich Merchant
MILD DRUGS

10 POINT with 18 Point Initials 4A 10A 18a \$3 85

Renowned Buildings
GAVE 28 PILE
EASTERN CASH

FAÇADE CONDENSED No 2

PATENTED

72 POINT

9 A 12 a \$13 50

Somnambulistic Excursion

60 POINT

12 A 16 a \$12 50

Modern Contrivance Desirable

54 POINT

12 A 16 a \$10 75

Remonstrations

48 POINT

12 A 16 a \$9 00

Unconscientious

42 POINT

14 A 18 a \$8 25

Generous Brothers

36 POINT

16 A 20 a \$7 00

Confidence Rewarded

30 POINT

16 A 20 a \$6 00

Government Examination

24 POINT

20 A 24 a \$5 00

Unbroken Promise Recorded

18 POINT

28 A 32 a \$4 75

Industrious Manufacturers Rewarded

16 POINT

30 A 34 a \$4 00

Americans Sending Largest Contribution

12 POINT

40 A 44 a \$3 75

Attention Given to Business Before Pleasure
1234567890

10 POINT

46 A 50 a \$3 25

Revised Histories of Celebrated Discoveries Completed
1234567890

FACADE CONDENSED,

PATENTED

72 POINT

9 A \$7 25

VENTURESOME YOUNGSTER

60 POINT

12 A \$6 75

DEMANDS QUICK EXPERIMENTS

54 POINT

12 A \$6 00

AUTHORIZATION

48 POINT

12 A \$5 25

GOVERNMENTAL

42 POINT

14 A \$4 50

RESULT OBTAINED

36 POINT

16 A \$4 00

CRANKS WANDERING

30 POINT

16 A \$3 50

STATESMEN ASTOUNDED

24 POINT

20 A \$3 00

NOCTURNAL AMUSEMENTS

18 POINT

28 A \$2 75

LARGE CONTRIBUTIONS REQUESTED

16 POINT

30 A \$2 50

DANGEROUS HOMEWARD PROMENADE

12 POINT

40 A \$2 25

ANCIENT SCIENCES AND MODERN ETHOLOGY

10 POINT

48 A \$2 00

FOREIGN QUESTIONS NEVER INTRODUCED BEHINDHAND

1234567890

1234567890

FACADE SERIES

PATENTED

60 POINT

5 A \$6 80

REQUIREMENT

54 POINT

5 A \$5 50

BRANCH ENGINE

48 POINT

5 A \$4 75

MOURNING HOURS

42 POINT

6 A \$4 25

DESCRIBE

36 POINT

8 A \$4 00

REDUCTION

30 POINT

9 A \$3 50

AMUSEMENTS

24 POINT

12 A \$3 25

CONSEQUENCES

20 POINT

16 A \$3 00

GENERAL RECORDS

18 POINT

18 A \$2 75

MORNING TELEGRAMS

12 POINT

25 A \$2 25

MANUFACTURING DEPARTMENTS

10 POINT

30 A \$2 00

REPAIRING ELECTRICAL INSTRUMENT

8 POINT

36 A \$1 75

ENORMOUS BARGAINS IN ARTISTIC FURNITURE

6 POINT

36 A \$1 50

MENAGERIES CONTAIN SOME REMARKABLE FEATURES

1 2 3 4 5 6 7 8 9 0

1 2 3 4 5 6 7 8 9 0

MURAL SERIES

PATENTED

48 POINT

4 A \$5 25

MONUMENTS

42 POINT

5 A \$4 75

GRAND HEIGHT

36 POINT

5 A \$4 25

DUSTER AND BRUSH

30 POINT

6 A \$3 50

INCREASE EXERTION

24 POINT

8 A \$3 25

BEAMS REMAIN WHITE

20 POINT

9 A \$2 50

EXACT FORCE

18 POINT

10 A \$2 50

MAIDS KNOWN

12 POINT

18 A \$2 25

NUMEROUS REPORTS

10 POINT

20 A \$2 00

COMPLIMENTS REQUIRED

8 POINT

26 A \$1 75

MAGNIFICENT AND EXTRAORDINARY

6 POINT

26 A \$1 50

SPECIAL RATES FOR BOYS AND GIRLS

<1234567890>

<1234567890>

STANDARD LINING ANTIQUE

30 POINT

8A \$3 75

BEAUTIFUL
CUBAN GIRLS

24 POINT

8A \$3 40

PROGRESSIVE
BOXING TEACHER

18 POINT

10A \$2 70

AMERICAN SAILORS
STRONG GOVERNMENT

12 POINT No 3

20A \$2 80

MIDSUMMER
NIGHT DREAMS

12 POINT No 2

20A \$2 30

SECOND-HAND
SEWING MACHINE

12 POINT No 1

20A \$2 00

MOUNTAIN CLIMBER
ROMANTIC ENTERTAINER

6 POINT No 5

30A \$1 75

TINWARE MERCHANDISE
MANUFACTURER AND JOBBER

6 POINT No 4

30A \$1 50

LAUGHING BABBLING BROOK
SPRING AND SUMMER ARE COMING

6 POINT No 3

30A \$1 25

PRESENT DIFFICULTY ACCEPTED
MOONLIGHT RAMBLING ON THE BEACH

6 POINT No 2

30A \$1 25

PENSIVELY LOOKING BACKWARD
EXALTED THOUGHTS AND WORTHY BEHAVIOR
1 2 3 4 5 6 7 8 9 0

6 POINT No 1

35A \$1 25

COLORS SATINS AND LINEN GOODS
ARRIVING DAILY ON THE STEAMSHIP INTERNATIONAL
1 2 3 4 5 6 7 8 9 0

MORTISED SERIES

PATENTED

48 POINT

3 A \$5 70

MORTISED

36 POINT

5 A \$4 30

VANISHMENT

24 POINT

9 A \$3 00

PATERNAL REGARD

18 POINT

12 A \$2 50

PATRIARCH

12 POINT

18 A \$2 10

RURAL HOMES

9 POINT

22 A \$1 80

WHITE ELEPHANTS
12345678

6 POINT

25 A \$1 45

YOUTHS DECORATE GRAVES
1234567890

EUREKA ALPHA CIRCLE

FROSTED COUGH LOZENGES

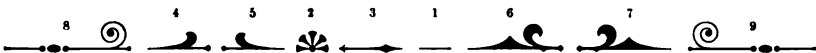

Furnished with the 48 Point size only

The letters C E F L Q and T are made each in two distinct widths in the 24, 36 and 48 Point sizes

AMERICAN OLD STYLE

48 POINT

4A \$4 00

POKER CHIPS

36 POINT

6A \$3 00

AMERICAN SHORE

30 POINT

8A \$2 75

BINDERS

24 POINT

10A \$2 50

RICH FAME

12 POINT

15A \$2 00

SUBMARINE TELEGRAPH
REGAL 3 HOMES

18 POINT

12A \$2 25

BRIGHT COLORS
FIND 4 COST

PLUTO SERIES

48 POINT

4A \$5 50

MUSTERING

36 POINT

5A \$4 25

NOVICE

24 POINT

8A \$3 50

MARINERS

12 POINT

18A \$2 25

FIRM ROUGH RIDERS
1234567890

18 POINT

10A \$3 00

GUBAN GUIDE
123456

QUAINT GOTHIC

48 POINT

5 A \$5 00

HORSE SALE

36 POINT

5 A \$3 50

AUTUMN CRUISE

24 POINT

8 A \$3 00

\$5 STOLEN

18 POINT

10 A \$2 50

638 CORNERS

12 POINT

12 A \$1 50

GRAND \$2 CONCERT

10 POINT

16 A \$1 25

INFERNAL 48 REGIONS

BLACK CAP

PATENTED

48 POINT

5 A \$4 65

KINETOSCOPES

36 POINT

7 A \$3 70

HOMERS

30 POINT

9 A \$3 15

FORESTER

24 POINT

12 A \$2 95

BRICK WORK

18 POINT

16 A \$2 35

GRAND WRINKLE

12 POINT

22 A \$1 85

WESTERN FOUNDRIES

8 POINT

30 A \$1 60

RAIN PROVIDED ON DEMAND

12345678

1234567890

ATLANTA SERIES

48 POINT

4A \$10 00

SOURS

42 POINT

4A \$7 25

MOVER

36 POINT

4A \$6 75

MINDING

30 POINT

5A \$5 00

GERALINE

24 POINT

6A \$4 50

GRAB ♦ BAGS

18 POINT

8A \$3 50

✻ STING ✻

14 POINT

9A \$3 25

✻ CROAKS ✻

12 POINT

12A \$3 00

GOOD ♦ DOGS

10 POINT

16A \$2 75

SWEET + MUSIC

8 POINT

20A \$2 50

✻ CALLED · LOUDEST ✻
1234567890

6 POINT

28A \$2 25

✻ COURAGEOUS · DEFENDER ✻
1234567890

VICTORIA SERIES

48 POINT

5 A \$8 50

VICTORIA

42 POINT

6 A \$7 25

CONSTRUE

36 POINT

6 A \$6 75

✻ SPURNED ✻

30 POINT

7 A \$6 00

CAPITAL · RING

24 POINT

8 A \$4 50

✻ COMFORTS ✻

18 POINT

10 A \$3 50

SPARROWS

14 POINT

12 A \$3 25

CONJUNCTIVE

12 POINT

16 A \$3 00

KINDLY + WORDS

10 POINT

20 A \$2 75

TENDER + AFFECTION

8 POINT

28 A \$2 50

* CHEERING + RECEPTION *
1234567890

6 POINT

36 A \$2 25

* UNRULY + CHILDREN + PUNISHED *
1234567890

ALASKAN SERIES

48 POINT

3A \$7 30

BONDS

36 POINT

4A \$6 00

MACHINE

24 POINT

6A \$4 50

REMOVE
RURAL TRACK

18 POINT

8A \$3 65

PURCHASE
NOBLE 56 RACER

12 POINT

10A \$2 05

REMOTE
RESORT QUIET

10 POINT

12A \$1 70

THUNDER
STORMS PRODUCE

8 POINT

16A \$1 70

SOUND BOATS
WEALTH NOT ACQUIRED
654 VERY EASILY

6 POINT

24A \$1 50

RELIABLE SECURITY
PEOPLE DESIRING HOME COMFORTS
FORMING GREATER 3456

TRINAL—Series Three

48 POINT

3 A \$6 25

ROSEBUD

36 POINT with 48 Point Initial 4 A \$5 40 3 A \$5 00

24 POINT with 36 Point Initial 6 A \$4 40 3 A \$3 50

EAST HONEY

TRINAL—Series Two

36 POINT

4 A \$4 40

GOLD MINER

28 POINT with 36 Point Initial 6 A \$4 25 3 A \$2 60

20 POINT with 28 Point Initial 8 A \$3 65 4 A \$2 10

ROMAN MEADOW

TRINAL—Series One

24 POINT with 36 Point Initials

INITIALS
6 A \$3 00 3 A \$2 80

NORTH 54 TIMBER

18 POINT with 24 Point Initial 8 A \$2 85 3 A \$1 50

INITIALS
12 POINT with 18 Point Initials 10 A \$2 50 4 A \$1 15

WEATHER FIFTH NOTE
A B C D G J K L

FOSTER GOTHIC EXTENDED

48 POINT

3A \$5 75

DREAM

36 POINT

4A \$4 50

HOE

24 POINT

6A \$3 75

ROBED

18 POINT

8A \$3 00

MADE
FISH SIGN

12 POINT

10A \$2 50

FRENCH
BARON HOME
BROADER

10 POINT

15A \$2 25

MARINERS
DEMAND FREIGHT
3458 BOATS

8 POINT

20A \$2 00

LANDSCAPE
BEAUTIFUL MOUNTAIN
SCENERY 6789

FOSTER GOTHIC EXTENDED No 2

24 POINT

6A 8a \$6 00

ENDORSE
Made Superb Chair

18 POINT

8A 10a \$5 00

GOLD
Bond Given

12 POINT

10A 12a \$4 00

FAMOUS
Writers Procure
345 Library

FOSTER GOTHIC

48 POINT

4 A \$4 75

NORTH RANGE

36 POINT

6 A \$4 25

HUNTS 586 BEARS

30 POINT

7 A \$3 75

REFORMED

24 POINT

8 A \$3 50

CUSTOMER

18 POINT

10 A \$2 75

PECULIAR
BANK 56 NOTE

12 POINT

14 A \$2 25

GATHERING
BEAUTIFUL BOUQUETS
CHRISTMAS 348

RIVET SERIES

24 POINT

8 A \$2 00

RECEIVING INSTRUMENTS
BEAUTIFUL DRAWING

18 POINT

10 A \$1 50

NOTED WINTER
BASE 8 BALL

12 POINT

12 A \$1 00

UNPARDONABLE LAWS
BOSTON 4 HARBOR
OVERHEARD SECRETS

ECCENTRIC SERIES

PATENTED

36 POINT

6 A 83 50

FARMER • SELLING • CORN

24 POINT

8 A 82 35

BOMBARDING • PORT • DELAWARE

ONSLAUGHT

18 POINT

10 A 81 90

FORWARD • THEIR • MONTHLY • CONTRIBUTIONS

1234567890

NEWFANGLE SERIES

PATENTED

36 POINT

4 A 12 A 85 60

HUMBUGS • AND • SORCERERS

24 POINT

6 A 18 A 84 85

SPECULATORS • RELIABLE • BAROMETER

18 POINT

6 A 24 A 83 95

MOZAMBIQUE • INVESTMENT • COMPANY • DEALING

1234567890

CHINESE SERIES

24 POINT

6 A \$2 40

ARTISTIC HEADGEAR
FINE DESIGNS

18 POINT

8 A \$2 25

WHALEBACK DESTROYER
VIOLENT STORMS

12 POINT

10 A \$1 60

SERVICE REFORM
COUNCILMEN
FORCED TO BEGIN

9 POINT

12 A \$1 20

EXCELLENT FORTUNES
APPRECIATED
COMFORTS OF BEAUTY

OXFORD No 2

36 POINT

3 A 6 A \$6 95

HORSE RACING

24 POINT

3 A 8 A \$4 55

SAIADS AND CIARETS

18 POINT

4 A 10 A \$4 20

NICE DAMES

1 2 3 4 5 6 7 8

12 POINT

5 A 12 A \$2 40

BICYCLE INVENTOR

1 2 3 4 5 6 7 8 9 0

ELANDKAY SERIES

36 POINT

6 A \$3 25

CHARMING SERIES

24 POINT

8 A \$2 50

BEST SIZES

18 POINT No 29

12 A \$2 00

SPRING STYLE

18 POINT No 28

14 A \$1 75

DESIRE RETURNS

12 POINT No 27

16 A \$1 50

UNKNOWN COUNTRY

12 POINT No 26

18 A \$1 50

FAVORABLE CONDITION

12 POINT No 25

24 A \$1 50

NEW POOLING COMBINATION
LOST OPPORTUNITY

6 POINT No 24

30 A \$1 50

GREATER ADMIRATION EXPRESSED
CONTINUAL PROGRESS

6 POINT No 23

30 A \$1 50

FAMOUS AUTHORS WORKS ARE EXTINCT
XYLOGRAPHY AND PHOTOGRAPHY

6 POINT No 22

40 A \$1 25

EXPECTANCY OF ITS PROMOTERS
NO QUESTION HAS AROUSED MORE INTEREST
1 2 3 4 5 6 7 8 9 0

6 POINT No 21

40 A \$1 25

BEST MATERIAL AND WORKMANSHIP
MICROSCOPIC ADJUSTMENT OF TOOLS AND MACHINES
1 2 3 4 5 6 7 8 9 0

JAGGED SERIES

12 POINT No 39

12 A \$1 75

BRIGHTON FLORAL EXHIBITION
MANY FOREIGN PLANTS SHOWN

ORNAMENTS FOR THE
JAGGED SERIES

No 39



12 POINT No 40

14 A \$1 75

GRAND COACHING PARADE
A PLEASANT ANTICIPATION

No 40



12 POINT No 41

18 A \$1 75

MOST PICTURESQUE RESORT
SKOWHEGAN'S CELEBRATED HOSTELRIES
1 2 3 4 5 6 7 8 9 0

No 41



OUTING SERIES

12 POINT No 46

14 A \$2 00

ARTISTIC MECHANICAL ENGRAVING
BEST AND CREAPEST

12 POINT No 47

16 A \$1 75

CONSTANT SEARCHERS BEST REWARDED
KNOWLEDGE OBTAINABLE

12 POINT No 48

18 A \$1 75

ANNUAL WATER CARNIVAL NEAR NANTASKET BEACH
WOMEN AND CHILDREN INVITED

6 POINT No 42

20 A \$1 75

MOUNTAIN TOURISTS RETURN
EXPERIENCE HARDSHIP

6 POINT No 43

30 A \$1 75

OPENING OF SPRING MILLINERY GOODS
NEW TRIMMINGS AND FEATHERS

6 POINT No 44

40 A \$1 50

FRESH PUBLICATIONS CIRCULATED
SEVERAL HISTORIC PERSONS ARE MENTIONED
1 2 3 4 5 6 7 8 9

6 POINT No 45

40 A \$1 50

FRESH IMPORTATIONS ARRIVING DAILY
COMMODIOUS QUARTERS FOR INCREASING PATRONAGE
1 2 3 4 5 6 7 8 9 0

MORNING GLORY

36 POINT

7 A 12 a \$5 00

Universal Protective Association Disbands
UNDESIRABLE BROTHERS

24 POINT

12 A 20 a \$4 00

We heartily extend to you a
special invitation to visit our
GREAT EMPORIUM 418

18 POINT

12 A 32 a \$3 25

The finest line of Novelties are here
for your inspection and you are sure
to be pleased with our grand display
SUPERIOR ARTICLES \$9.267.50

VICTORIA ITALIC

24 POINT NO 1

8 A \$3 75

EXCURSIONIST

24 POINT NO 2

8 A \$3 25

SEVERE STORMS

18 POINT NO 1

12 A \$3 25

MIDNIGHT RAMBLE

18 POINT NO 2

12 A \$2 75

SUBURBAN RESIDENCE

12 POINT NO 1

16 A \$2 50

*DECOROUS SPINSTERS
MUTUAL ADORATION SOCIETY*

12 POINT NO 2

16 A \$2 25

*LUDICROUS AND ANNOYING
SUDDEN BURSTING OF PANTALOONS*

12 POINT NO 3

18 A \$2 00

*FLOWER PLANTS
GERANIUM ADMIRER*

6 POINT NO 1

30 A \$2 50

*ROYAL VISITORS
SALUTING THE FLAGSHIP*

6 POINT NO 2

30 A \$2 25

*HUMOROUS ANECDOTES
GUARDED SECRETS OVERHEARD*

6 POINT NO 3

30 A \$2 00

*ROBINSON CRUSOE OUTDONE
HISTORY OF SINBAD THE MARINER*

6 POINT NO 4

36 A \$2 00

*HARMLESS SIMPLETONS RAMPANT
VICTIMS OF CHEAP AND TRASHY NOVELS*

1234567890

6 POINT NO 5

36 A \$2 00

*CYCLONIC WINDS RAGING FIERCELY
DESTRUCTIVE STORM DEMOLISHING PROPERTY*

1234567890

LINE STRICTLY ACCURATE SIGN

REGAL ITALIC

36 POINT

4 A 8 a \$6 50

HIRE Domestic

30 POINT

5 A 10 a \$6 00

Emblematic CORDS

24 POINT

6 A 12 a \$5 25

ACHIEVEMENT
Meritorious Instruction

18 POINT

7 A 14 a \$4 50

MONROE DOCTRINE
Historic Document Published

14 POINT

9 A 18 a \$4 20

LEARNED EDUCATORS
Conclusive Academical Examination

12 POINT

12 A 24 a \$4 00

GYMNASIUM
Masculine Exerciser

10 POINT

14 A 28 a \$3 50

ORGANIZATION
Universal Peace Societies

8 POINT

18 A 36 a \$3 00

SURGICAL RECORDS
Scientific Theories Examined
1234567890

6 POINT

24 A 48 a \$2 50

INFORMATION BUREAU
Valuable Services Rendered Citizens
1234567890

See following page for practical display of Regal Italic

REGAL ITALIC

Gents' Furnishings

Fall Styles Ready

HORACE QUICK
Salesman

Representing
RICHMOND & PASMORE

Baltimore, Md.

CHARLES NORTH

JACOB SIMON

NORTH & SIMON

Wholesale and Retail

Leather Dealers

3268 CORNING STREET

Kansas City, Mo.

Dr. George Ketchum
NERVE SPECIALIST

26 Medical Street

Quacktown, Penna.

Office Hours
9 A. M. to 3 P. M.

See preceding page for prices of Regal Italic

COPPERPLATE ROMAN

10 POINT

20 A \$3 00

MORNING EXERCISE REQUIRED
DR GUREMUP RESIDES AT N° 86 FIRST ST

8 POINT

25 A \$2 75

EXPERIENCED MUSICAL INSTRUCTOR
VIOLINCELLO SEASON OPENS NOVEMBER 21ST, 1899

NOTE THE
ENGRAVED
EFFECT

DR G. PHYSIQUE
N° 286 CANAL ST
NUX VOM, D.C.

OFFICE HOURS
8.30 TO 10.00 A.M.
2.00 TO 4.30 P.M.

MR AND MRS FRANK ALLISON

AT HOME
WEDNESDAY AFTERNOON

N° 518 NORWICH ST

6 POINT No 1

30 A \$1 25

AMERICAN MERCHANDISE COMPANY, N° 1579 MARKET ST
FASHIONABLE PARISIAN EMBROIDERY AND FABRICS OF SUPERIOR MERIT

6 POINT No 2

60 A \$1 75

MR AND MRS FRED ARBORGROVES
ESTABLISHING MATRIMONIAL BUREAUS
?? 1234567890 ??

6 POINT No 3

60 A \$1 75

KLONDIKE INVESTMENT COMPANY
AMERICAN GOLD AND SILVER CERTIFICATES
?? 1234567890 ??

SKJALD SERIES

PATENTED

60 POINT

4 A 5 a \$10 35

Lower Case \$4 45

HUNDRED

Mexican 46

48 POINT

4 A 5 a \$8 65

Lower Case \$3 25

GOOD FINES

Bold 28 Action

36 POINT

6 A 8 a \$7 50

Lower Case \$3 00

HONEST HEART

Strong 75 Friends

ARCHAIC SERIES

36 POINT

7 A 10a \$6 00

FRIENDLY DEALING
 Houses can be bought
 at terms of Purchaser

12 POINT

25 A 40a \$3 10

SALE WHICH IS OF INTEREST TO EVERYBODY

WE beg to announce that we have engaged the services of Mr. F. Dawson, the well-known decorative artist, to design and execute all kinds of Interior Decorative Work, including Woodwork in the artistic manner for which he has the highest reputation. His superb stock has been bought by us, and is now on exhibition

FAIR, DEALER & COMPANY

'Phone 2345

Cor. Broad and Center St.

30 POINT

8 A 14a \$5 00

ENAMELED BEDSTEADS
 Bargain sale of Furniture
 will commence on Friday
 Afternoon at 2.30 o'clock

ARCHAIC SERIES

24 POINT

10A 18a \$4 25

DESIRABLE LOT OF FABRICS
Remnants of Dress Goods will be for sale at Second Counter, Northern Aisle, and it will pay to look at them... 234 Patterns

9 POINT

30A 50a \$2 90

SALE OF FANCY POTTERY

Our sale of China, Cut Glass and Eric-a-Brac commences to-day. The main and cross aisles of the first floor are filled from end to end this morning with an extensive showing of Decorative and Table Wares of new design

A. MERCHANT

289 Elbow Lane, Troy, O.

6 POINT

36A 70a \$2 70

BARGAINS IN BOYS' FURNISHINGS

Now is the time to get boys rigged out for school, and it will be an easy task for mothers if they will pay us a visit and look over our large stock of Clothes, which are sold at prices within reach of all. Double-breasted Suits, of all-wool fancy chevots and cassimeres, medium and dark colors in gray and brown, in checks, overplaids and plaids. Coats are lined with satin, and finished equally as well as those costing \$8.75 or more

BOIES, OUTFITTER & CO.

6238 Fourth Avenue

18 POINT

14A 26a \$3 75

PRETTY DRAPERIES FOR THE PARLOR

Choosing in Lace Curtains from our stock is safely satisfactory, because we always exercise great care in selecting patterns. We have picked carefully the best styles, and are selling about 1250 pairs every day

 POSTER COMMERCIAL

30 POINT

Card Font 6 A 12 a \$3 65
Circular Font 10 A 5 A 42 a \$9 75

METHOD AND MEANS
WHEN, in course of human history, it becomes necessary for a nation to dissolve political bands which have connected it with another, and to assume among 564

18 POINT

Card Font 10 A 16 a \$2 50
Circular Font 20 A 10 A 125 a \$11 75

INDEPENDENCE TO DECLARE
WHEN, in the course of human events, it becomes necessary for one people to dissolve the political bands that have connected them with another, and to assume among the powers of the earth the separate and equal station to which the laws of nature and of nature's God entitle them, a decent respect for the opinions of mankind requires that they declare the causes which impel them 52

POSTER COMMERCIAL

12 POINT

Card Font 12 A 20 a \$1 80
Circular Font 48 A 20 A 200 a \$11 25

PATRIOTIC ASPIRATIONS OF PIONEERS

WHEN, in the course of human events, it becomes necessary for one people to dissolve the political bands which have connected them with another, and to assume, among the powers of the earth, the separate and equal station to which the laws of nature and of nature's God entitle them, a decent respect to the opinions of mankind requires that they should declare 123

10 POINT

Card Font 16 A 24 a \$1 80
Circular Font 60 A 25 A 250 a \$12 25

REVOLUTION HEROES COMPOSE INDEPENDENCE

WHEN, in the course of human events, it becomes necessary for one people to dissolve the political bands which have connected them with another, and to assume, among the powers of the earth, the separate and equal station to which the laws of nature and of nature's God entitle them, a decent respect to the opinions of mankind requires that they should declare the causes which impel them to the separation. We hold these truths to be self-evident, that all men are created equal; that they are endowed with certain 456

8 POINT

Card Font 20 A 30 a \$1 75
Circular Font 60 A 25 A 350 a \$11 50

UNITED STATES GOVERNMENT CONSTITUTIONAL DECLARATION

WHEN, in the course of human events, it becomes necessary for one people to dissolve the political bands which have connected them with another, and to assume, among the powers of the earth, the separate and equal station to which the laws of nature and of nature's God entitle them, a decent respect to the opinions of mankind requires that they should declare the causes which impel them to the separation. We hold these truths to be self-evident, that all men are created equal; that they are endowed by their Creator with certain unalienable rights; that among these, are life, liberty and the pursuit of happiness. That, to secure these rights, governments are instituted among men, deriving their just powers from the consent of the governed; that, when 782

IVANHOE SERIES

36 POINT

4 A 5 a 85 50

PARIS GREEN
Mystery Lovers

30 POINT

4 A 6 a 85 25

BRAVE SOLDIER
Constant Traveler
Reciprocate Again

24 POINT

6 A 10 a 84 75

ELEGANT SOUVENIR
Choice Spanish Cigars
Shareholders Dividend

18 POINT

8 A 12 a 83 75

BUILDING RUSSIAN PRISON
Entrancing Ethiopian Warbling
Comical Iroquois Performances

IVANHOE SERIES

12 POINT

Card Font 10 A 16 a 82 40
Circular Font 25 A 125 a 811 75

WONDERFUL YERKES TELESCOPE AT WORK IN FINE FORM IN WISCONSIN

The object-glass for the Yerkes telescope has been completed and tested, and the giant instrument is now in operation at the new observatory established by the University of Chicago at Lake Geneva, Wisconsin. The Yerkes telescope now takes precedence over the Lick telescope, and an interesting comparison of the two may be 3579

10 POINT

Card Font 10 A 18 a 82 35
Circular Font 30 A 140 a 811 85

GREAT CHINESE NAVAL BATTLE OFF YALU RIVER MODERN SHIPS SHELLED

In the great naval battle off the Yalu River last year the Chinese iron-clad battle-ship, Chen Yuen, was commanded by an American named Philo McGriffen, a graduate of the Naval Academy at Annapolis. Captain McGriffen, who has but lately recovered in part from injuries received in this already historic battle, gives many strikingly interesting details illustrative of the terrible nature of a modern naval battle 1658

8 POINT

Card Font 12 A 20 a 82 40
Circular Font 36 A 180 a 810 75

THE CRADLE ASKS US WHENCE, AND THE COFFIN WHITHER IS LIFE WORTH ALL OUR ANXIETY

My friends: I know how vain it is to gild a grief with words, and yet I wish to take from every grave its fear. Here in this world, where life and death are equal kings, all should be brave enough to meet what all the dead have met. The future has been filled with fear, stained and polluted by the heartless past. From the wondrous tree of life the buds and blossoms fall with ripened fruit, and in the common bed of earth the patriarchs and babes sleep side by side. Why should we fear that which will come to all that is? We cannot tell, we do not know, which is the greater blessing—life or death. We cannot say 1565

ARLINGTON SERIES

48 POINT

4 A 5 a \$7 75

HOME SONGS
 in autumn time
 after the sun is

36 POINT

5 A 8 a \$5 50

OVER THE BRIDGE
 near the pasture on
 uncle John's farm ~

30 POINT

6 A 9 a \$5 00

DICKIE BIRDS SINGING
 their tuneful notes over
 forest and meadows ~ ~

ARLINGTON SERIES

24 POINT

8 A 10 a \$4 00

ORDER DECEMBER NUMBER
 at seaside or inland agencies,
 sample copies on demand ~ ~

18 POINT

10 A 16 a \$3 25

EIGHT HUNDRED PAGES OF HUMOR
 and jokes made extremely ridiculous
 by scores of speaking pictures, with
 introductory excuses by the authors

12 POINT

16 A 20 a \$3 00

MOST CONSPICUOUS AMONG WHICH ARE DOOLEY
 that authentic, picturesque and realistic delineator of
 things that his friend, Mac, might have done if he was
 him, and two other gentlemen of national reputation,
 who have proven alibis just as our forms go to press

10 POINT

20 A 26 a \$2 75

REMARKABLY INTERESTING FROM COVER TO THE FINIS VIGNETTE
 adorning the lower section of the last page. Don't miss this edition de
 luxe. If you cannot spare the trifling sum we value it at, the money is
 easily procurable in several ways, the surest of which is perhaps the
 endless chain. If you start one, have all letters addressed to us ~ ~ ~ ~

1 2 3 4 5 6 7 8 9 0

ELZEVIR GOTHIC

60 POINT

3 A 5a \$11 50

GAMES
Fast Horses

48 POINT

3 A 6a \$8 00

CHARM
Roman Guard

36 POINT

5 A 9a \$6 00

MONUMENTS
Grandeur Described

30 POINT

6 A 12a \$5 50

COUNCILMANIC
Independent Convention

ELZEVIR GOTHIC

24 POINT

8 A 16 a \$5 00

MOUNT VESUVIUS
Gorgeous Palaces Destroyed
Violent Eruption

18 POINT

12 A 24 a \$4 50

NATIONAL PREROGATIVE
Liberal Reform Movements Indorsed
Municipal Resolution

14 POINT

18 A 30 a \$4 00

FAMOUS ELOCUTIONISTS ENTERTAIN
Distinguished Orators Receive Congratulations
Linguistic Powers Unsurpassed

12 POINT

18 A 36 a \$3 50

£ NATIONAL CONVENTION CONSIDERED £
International Monetary Questions Frequently Discussed
Organization Committee Reports

10 POINT

20 A 40 a \$3 00

HANDSOME PREMIUMS AWARDED COMPETITORS
Collection of Botanical Specimens and Delicate Wild Flowers
Floricultural and Horticultural Exhibition

8 POINT

22 A 44 a \$2 75

IMPROVEMENT OF MANKIND
Advocating Protection for the Honest
Our Industrial Conditions
1 2 3 4 5 6 7 8 9 0

6 POINT

25 A 50 a \$2 50

MORALS OF THE GENERAL PUBLIC
Dawn of Civilization and Decrease of Crime
Modern Religious Thoughts
1 2 3 4 5 6 7 8 9 0

FLORENTINE OLD STYLE No 2

72 POINT

4 A 5 a 89 50

NOVICE
White Frost

60 POINT

4 A 5 a 89 00

BRONTERN
Florentine 85

48 POINT

5 A 5 a 87 00

AMERICANS
Desired 9 Efforts

FLORENTINE OLD STYLE No 2

36 POINT

6 A 8 a \$6 00

POPULARITY
Increased & Demands

24 POINT

10 A 10 a \$5 00

CONSIDERED HOSTILITY
Distinguished \$26 Repudiators

18 POINT

15 A 14 a \$4 50

TWENTIETH ADMINISTRATION
Presidents Message Before the House

12 POINT

20 A 24 a \$3 75

Like a speck of sunshine
Flits the butterfly
Like a little cloudlet
Hung up in the sky

10 POINT

25 A 32 a \$3 25

Winging o'er the children
Like a winged flower
Form of fairest beauty
In the summer hour

8 POINT

30 A 32 a \$2 75

It grew where Nature wild and grand
Had known no fawdry Art
But with its beauty in the land
Had won the poet's heart

6 POINT

36 A 40 a \$2 50

See the children watch it
From the flowery ground
Winged bit of sunshine
Circling round and round

SCHOEFFER OLD STYLE

PATENTED

72 POINT

3 A 4 a \$8 50

DESERVING
Student tried
for Diplomas

60 POINT

3 A 5 a \$7 00

REMARKABLE
Time was made
on the Voyages

SCHCEFFER OLD STYLE

PATENTED

48 POINT

4A 7a \$6 00

BRIGHT PERSONS
Blessed with Sound
Health and Millions

36 POINT

6A 9a \$5 00

CHARITABLE REMEDY
We should always assist
those who are deserving

30 POINT

8A 12a \$4 50

INTREPID AND PATRIOTIC
They stood on the deck like
heroes, so firmly intent were
they on the seizure of the fort

SCHCEFFER OLD STYLE

PATENTED

24 POINT

12 A 18 a \$4 00

ADVANTAGES OF KNOWLEDGE

FORTUNE may be left to us by our parents, but the resources of education must be developed by ourselves, or we must lack it forever

48 POINT SCHCEFFER OLD STYLE INITIALS 3 A \$4 00

10 POINT

25 A 50 a \$2 25

FOR HIS GREAT QUALIFICATION PETER SCHCEFFER WAS MADE MANAGER OF THE OFFICE IN MENTZ

PETER SCHCEFFER before the age of twenty years was considered a perfect copyist of old manuscripts, with a slight knowledge of printing taught him by Gutenberg. He attracted the attention of Fust, who found in him one who could cleverly manage a Printing Office, and by adding to his great knowledge the acquirement of ingenuity, he made many acceptable changes in the pages of the Bible and Psalter. Between 1462 and 1464 turbulent times occurred in Mentz and business was at a standstill.

24 POINT SCHCEFFER OLD STYLE INITIALS 6 A \$2 50

18 POINT

15 A 25 a \$3 50

DIFFICULTY IN CHOOSING COMPANIONS

THE task is a dilemma, but we all should endeavor to make a good selection and not come to hasty conclusions as to the relative value of our friends, for in many instances time may develop a different phase of character, and

36 POINT SCHCEFFER OLD STYLE INITIALS 4 A \$3 50

SCHÖEFFER OLD STYLE

PATENTED

15 POINT

18 A 30 a 83 00

AN IDEA OF DISCOVERING A NEW HEMISPHERE

IT was Columbus, the intrepid Italian, who conceived the idea about the world being round instead of flat, and who sailed off into an unknown sea in the expectation to discover a hemisphere of two continents. Encouraged by the Spanish Crown in his undertaking, he set sail on August 3, 1492, sailing in a westerly direction.

36 POINT SCHÖEFFER OLD STYLE INITIALS 4 A 83 50

8 POINT

25 A 50 a 82 00

A CURTAILED DESCRIPTION OF SOME THINGS THAT WERE NOTICED WHILE EXPLORING THE GREAT MAMMOTH CAVE

THIS is a very interesting journey indeed. On arriving at the Cave one is astonished to view an immense rock over the entrance supported only by a very small stone, which if displaced would close the entrance forever and entirely entomb those inside. Leaving this fear aside, we find, on entering, several large rooms of wonderful size, also a running stream, a star-chamber, lighted by numberless small stars, and many strange carvings surprising to behold and to contemplate. Some of the chambers are very cold and others warm. This is said to be from changes of wind, in the same manner as those above the ground. The wonders of the Cave are explained by an experienced guide, without whose aid one would be lost forever in the vast space of this natural wonder.

15 POINT SCHÖEFFER OLD STYLE INITIALS 6 A 81 50

12 POINT

20 A 40 a 82 05

FEW THOUGHTFUL POINTS ON THE STUDY OF ASTRONOMY

IT will be very interesting, to many of us, to note the fact that during the month of August there is to be seen Jupiter and Venus in conjunction. It takes place low down in the western part of the horizon, and will be worth all the trouble we can take to witness such beautiful display; also the conjunction of Jupiter and the Moon, and Venus and the Moon. It is an infrequent occurrence to see these three bodies so close together, and the students should therefore avail themselves of this rare opportunity of viewing them.

24 POINT SCHÖEFFER OLD STYLE INITIALS 6 A 82 50

JENSON OLD STYLE

72 POINT

4 A 5 a \$12 00

ROMANS
Grand pieces
third year 25

60 POINT

4 A 5 a \$12 25

FOUNDERS
Original model
artistic faces 13

For Initials and Embellishments suitable for use with above Series, see pages 555-588 and 650-000

JENSON OLD STYLE



54 POINT

4 A 5 a 810 25

ORIGINAL
 English founders
 cast Diamond as
 far back as 1700

48 POINT

4 A 5 a 87 75

DESIGNING
 The date at which
 we quit the survey
 is not glorious  

For Initials and Embellishments suitable for use with above Series, see pages 555-558 and 650-600

JENSON OLD STYLE

42 POINT

4 A 6a \$7 25

DARING RIDERS
Surge over the plains
beyond 36 castles. 

36 POINT

5 A 8a \$5 00

SINGLE 25 JUSTICE
Full of healthy sense and
inspiration for all nations

30 POINT

6 A 10a \$3 00

DEMAND FOR UNIQUE
Effects which surprise the eye
and amaze the brain cost less
in the end than ordinary 780

For Initials and Embellishments suitable for use with above Series, see pages 585-588 and 656-660

JENSON OLD STYLE

24 POINT

10A 15a 84 50

PRICES BASED ON FIGURES

The check to uncertain estimating is in keeping a record of every item of expense that enters into the work and comparing it with the estimate when the job is completed. It is the only practical method of arriving at tangible facts on which to base the cost of your own productions 47 

18 POINT

12A 20a 84 00

ENLIGHTEN HONEST CUSTOMERS

In one particular it is always wise to enlighten every patron in order to reach a basis of mutual understanding when contracts are made. Most people are more or less ignorant of the customs and terms of the trade. This ignorance leads to much disputing and rankling dissatisfaction on the part of customers. Well-meaning and honest though they are, it is difficult for them to understand why the bill should be \$329 

For Initials and Embellishments suitable for use with above Series, see pages 585-588 and 656-660

JENSON OLD STYLE

14 POINT

15 A 25 n 83 50

ON THE PROGRESS IN MACHINERY AND
THE MAKING OF NEW TYPE FACES

IN 1835 I saw for the first time the printing house of Harper & Brothers. With childish awe I watched the flutter of the friskets of a dozen hand presses, and the slow but steady piling-up of printed sheets on the bank. Could any machines be finer or better? So I thought, and so Harper & Brothers thought; but in a few years the hand presses were supplanted by the Adams. This change was but the beginning of a series of changes that I can sketch in outline only. The two-roller Adams of wood frame was followed by the four-roller machine of iron frame and \$4295

12 POINT

18 A 30 n 83 25

MODERN VERSION OF THE WORLD OLD STORY
OF MAKING BRICKS WITHOUT STRAW

WHEN we discover here and there a printer wasting his energies and abilities in the vain endeavor to execute printing to the satisfaction of his clients with type lacking in originality, in art, and devoid of the life that can only be imparted by a genius in designing, we are reminded of the cruel task allotted to the Hebrews by the old Egyptians. There is neither profit nor pleasure in trying to impart an artistic effect with in-artistic type. It is a question whether the durability of such type is not an added injury to the unfortunate printer who uses it. Pound for pound the type of the American Type Founders Co. costs no more than type unenlivened by artistic merit; but in its true value it surpasses all other type as the masterpieces £376

For Initials and Embellishments suitable for use with above Series, see pages 585-588 and 656-660

JENSON OLD STYLE

8 POINT

25 A 35 a \$2 75

THE MANUFACTURERS OF OUR MACHINES ASSURED US AGAIN AND AGAIN THAT THEIR LAST MACHINES WERE PERFECTION.

LT was not possible to make anything better; they would meet every demand for strength, speed, accuracy, and ease of handling. So they did for a time; but in a few years on came the improvements, once declared impossible, and in the form of larger and more efficient machines. The presses that were the best of their kind in 1865 proved too small and too slow in 1875. To continue to use them would be to do work at cost or at loss. When one has room enough, the old machines may be set aside and put to an inferior class of presswork. But when rents are high and space is contracted the old machines must be sold. What do we get for old presses? It often happens that after only seven or ten years of service, the press that cost \$3000 or \$5000 will be sold for from \$300 to \$600. It is not worn out, it may be in good condition, and should be efficient for twenty years more, but it must be sold because it is not up to present needs. It will not pay to keep it when your rival is using new machines.

6 POINT

35 A 50 a \$2 50

A GOOD FEATURE IN PREVAILING FASHIONS IS THE GENERAL DISLIKE FOR ALL ORNAMENTAL AND FRAIL TYPES.

WHEN Whittinghouse of London revived the trade for old style letter, in 1844, the old order changed. Not liked at all in the beginning, old style slowly grew in favor, especially with those who wished to give distinction to their work. Before 1860 it was required of every prosperous book and job printer that he should have a full series of old style faces, complete from Pearl to Canon. This compelled a doubling of the expense of equipping the composing room; but if the demand for novelty had stopped here, this added expense might not need any notice. But it did not stop with the modernized old style. Think of the varieties now offered to us by the type founders—Caslon, Franklin, Barth, Binny, Ronaldson, Cadmus or Elzevir, French, Jenson, etc. Nor is this all: other faces with peculiar mannerisms are made abroad, and there are publishers who will have them. Standard or modern-cut Roman is provided by type founders in greater variety. The book printer who has two faces only in series soon finds them insufficient. He has demands for others.

10 POINT

25 A 30 a \$3 00

HE HAS DEMANDS FOR FACES BOLD AND BLACK, LIGHT AND SKINNY, BROAD, CONDENSED, LARGE

SMALL, with long ceriph, with short ceriph, with high ascenders, with short descenders, and other mannerisms too tedious to describe. We are asked to get these in fonts of thousands of pounds, but to buy half of them, or quarter of them, is to invite bankruptcy. There are publishers who ask that thousands of pages be kept standing for months. There are men before me who have sent, and are sending, proofs to Europe, and even to the Pacific Islands, and Asia. A prominent printer of Paris told me that the weight of the book types in his house largely exceeded two million pounds. The tied-up pages piled up like bricks on every floor of the house was proof of the statement. Fifty years ago a book and job printer could keep sixty compositors at work on a plant of types and appurtenances that cost less than \$10,000.

For Initials and Embellishments suitable for use with above Series, see pages 585-588 and 656-660

JENSON ITALIC

72 POINT

4 A 5 a \$17 00

Our Reports
were valued
SECURE

60 POINT

4 A 5 a \$12 25

Roman Letters
were invented
MODERN

JENSON ITALIC

54 POINT

4 A 5 a 810 25

*German printers
used bold Black
Type which was
PRINTED*

48 POINT

4 A 5 a 87 75

*In early history the
first type Printers
in the Monasteries
RECEIVED*

JENSON ITALIC

42 POINT

4A 6a 87 25

*Italic type is claimed
by historians to be a
good imitation of the
writings of Petrarch*
HISTORICAL

36 POINT

4A 6a 85 50

*The honor of introducing
Italic has been bestowed
on Aldus Manutius, who
used it in classical works*
INTRODUCTION

For Jenson Italic ornamental lower-case, see page 418

JENSON ITALIC

30 POINT

5 A 10a \$5 00

The original Italic letter was called Venetian or Aldine and was defaced by very strange irregularities in the formation of the slope of the characters

MALFORMATIONS

24 POINT

6 A 15a \$4 50

Astonishing strides in the designing of Italic type have been made in the last few years. The improvements made in their beauty and the general up-to-date style of their characters reflect a high degree of superiority on the skill of the modern designer

ADVANCEMENTS

For Jenson Italic ornamental lower-case, see page 418

JENSON ITALIC

18 POINT

10 A 25 a 84 00

Jenson Italic as a display type is a decided novelty. It is distinct in style and striking in character. It is made to the same line as the Jenson Old Style, and its value as a companion letter will be appreciated by printer and advertiser

CHARACTERS

12 POINT

18 A 40 a 83 25

Makers of Advertisements who formerly recommended the use of old style letters to their clientele will recognize in the Jenson Italic a monotony-breaking substitute, and the reading public will see it and be impressively attracted by advertisements set in this modest and character-giving letter. The aim of writers of advertisements is naturally to attract business to themselves, and that can only be done by attracting the great mass of readers to those who advertise

MAKING PROFITS

PARTICULAR ATTENTION IS DIRECTED TO THE BEAUTY OF THE CAP LINES IN THIS SERIES

The Jenson Italic

Ornamental lower case letters are intended to be used exclusively as final letters. To get the very best results they should be used sparingly in all classes of work. One or two letters properly placed in a job will add to its attractiveness.

The Jenson Italic

*Ornamental lower case letters are made in three characters *n g y* and are cast in all the sizes from 12 Point to 72 Point.*

The Jenson Italic

Ornamental lower case characters are not put up with regular fonts, as all fonts are complete without them. They are furnished at the following prices per font:

12 POINT, 18 POINT AND 24 POINT
EACH 50 CENTS

30 POINT, 36 POINT, 42 POINT, 48 POINT
EACH 75 CENTS

54 POINT, 60 POINT AND 72 POINT
EACH \$1 00

JENSON ITALIC

10 POINT

20 A 45 a 83 00

THE type made by the American Type Founders' Company is conceded by expert printers to outrank all competitors in its beauty of design, style of finish, and admirable wearing qualities. These three cardinal features are, in themselves, sufficient to recommend them to the vast army of purchasing printers and magazine publishers as a money-saving investment

O Leon, my lover,
Why should you despair,
When Love comes unbidden
With wreaths in his hair?
I love you, my Mona,
Is easy to say
As bird on the tree-top
To sing out his lay.

POINTS TO CONSIDER

8 POINT

20 A 50 a 82 75

JENSON TYPE.

In Jenson type my printer knows
The height of typographic pose;
The black-faced letters cross the page
Like mummings of some by-gone age
In solemn, sad, funereal rows.

No matter what is said, "it goes,"
Though doggerel verse—puerile prose—
If but its wretched rantings rage
In Jenson type.

Go, foolish rhyme, and dress your woes
In this prevailing garb of those
Who call all well that fits the gauge
Set by the mediaeval sage—
You too, may conquer, I suppose,
In Jenson type.

NOW to the point that pinches mankind the hardest—the unloosening of the purse-string—and has been the subject of frequent discussions for time immemorial. In figuring on the cost of new type do you regard it as an unnecessary expense or in the light of a good investment to buy the best? If as an investment, suppose a first-class, distinctive style of type costs you a little more than the ordinary and less attractive design, but the returns from the former are double the returns from the latter, which one would you select? You won't hesitate to choose that which is the most profitable.

ARGUMENT AND EXPLANATION

6 POINT

20 A 50 a 82 50

EVERYTHING that is required in a printing office, from a pair of tweezers to a perfecting press (to say nothing of type) can be supplied on the shortest notice by any Branch House of the American Type Founders' Company. These Branches are all conveniently located throughout the United States for the benefit of the trade and to facilitate the work of supplying the demands made upon us by an appreciative and increasing patronage. Therefore, place your orders with Branch nearest your place of business to insure promptness. A printing office completely supplied with the products of our manufacture is worth far more for use or sale than one made up from the productions of incomplete type foundries.

O Mona, you tease me,
And vex me for aye;
But, Mona, I love you,
Shall love you anyway;
I would to the altar
Now lead you a bride,
But love makes me falter
And sway with the tide.

Then bye, oh bye, darling,
For Mona must part
From Leon her lover
With dread in his heart;
Your love is the dewdrop
That dies in the sun,
Good-by, and forever,
With Mona unwon!

INFORMATION FOR THE ENTERPRISING

1234567890

SATANICK OPEN

PATENT PENDING

72 POINT

4 A 5 a \$17 00

Satanick 8

80 POINT

4 A 5 a \$12 25

Land 3 Mark

64 POINT

4 A 5 a \$10 25

6 Dead Soldier

48 POINT

4 A 5 a \$7 75

friends 7 Grave

36 POINT

5 A 8 a \$5 50

Cunard & Stuart \$2

.24 POINT

6 A 15 a \$4 50

Patriotism &

18 POINT

8 A 25 a \$4 00

Railway 58 Coach

SATANICK SERIES

72 POINT

4 A 5 a \$17 00

Standards

60 POINT

4 A 5 a \$12 25

Demonstrate

54 POINT

4 A 5 a \$10 25

Musicians
Enchantment

48 POINT

4 A 5 a \$7 75

Senatorial
Administrative

SATANICK SERIES

42 POINT

4 A 6 a \$7 25

Enthusiastic
Soldiers Marched

36 POINT

5 A 8 a \$5 50

Cultivators
Mirthful Harvesters

30 POINT

6 A 10 a \$5 00

✿ Legerdemain ✿
Necromancer Rehearsing

24 POINT

6 A 15 a \$4 50

Beautiful Landscape
Realistic Paintings Exhibited

18 POINT

8 A 25 a \$4 00

Rambling Tourist Enchanted
Inspiring Mountain Scenery in Autumn

SATANICK SERIES

12 POINT

10A 35 a \$3 25

AMERICANS have realized within recent years that there are some provinces by the sea, located as the mariners would say nor'-nor' east of us, which for wholesome climate and varied sights offer a greater wealth of attractions during summer days than is possessed by any other nearby region. Geographers have given to them the name of Maritime Provinces

8 POINT

15A 50 a \$2 75

THE SHOOTING on Prince Edward Island during the season is exceedingly good, and wild geese, brant, duck, partridge, woodcock and snipe are to be found in abundance, while such streams as the Monce, the Dunk, the Pierreaques, the Miminigash, the Kildare, Tignish and others, teem with trout and salmon. From any one of the little seaside towns on Prince Edward Island one may have within a half-hour or hour's sail an abundance of mackerel and deep-sea fishing. The island constitutes the smallest of the provinces, but maintains equal dignity with the greatest, having its own provincial government, comprising a governor and parliament, and sending six commoners to

10 POINT

12A 40 a \$3 00

ESTWARD from Windsor the country takes on a different character. Barren rocky slopes have given way to fertile fields. The hills have drawn apart and the Gaspeau Valley spreads out its verdure-covered meadows and luxuriously-foliaged orchards on every hand. Over to the right sparkles the Bay of Minas, and outlined on the horizon is grand old Blomidon, that majestic bastion, keeping faithful sentinel, as in the days of Evangeline, over the turbulent waters, which rise and fall with mighty force at its rocky base, guarding the peaceful valley

6 POINT

15A 50 a \$2 50

FROM HALIFAX fishing trips may be taken either by the several coach lines along the coast, or by private conveyances, which are to be obtained at reasonable cost. There is good sport along the western shore all the way to Chester and Gold River. Indian River, twenty-one miles from Halifax, and Ingram River, distant twenty-five miles, are also good points, as is Grand Lake. At St. Margaret's Bay may be found an old-fashioned inn and guides. Indian Lake, about eight miles from Halifax, on the Prospect Road, Deters Lake, Spruce Hill Lake and Nine Mile River are good points for the Spring and Summer sport. It is impossible, in an article of this length, to give a list of all the favorite places for sport, but this information can readily be secured in Halifax or any of the larger or smaller towns. No reference to fishing in the Provinces would, however, be complete without mention of that most famous of all salmon waters, the Margaret River, in Cape Breton

BRADLEY EXTENDED

60 POINT

3 A 4a \$10 50

Spend your
Bank Notes
in Pleasure

48 POINT

3 A 6a \$8 50

Nothing would
Satisfy People
so Much as to
know a Friend

BRADLEY EXTENDED

36 POINT

4 A 10a \$6 50

**Timely Hints often
Make Fortunes for
Shrewd Negotiator**

30 POINT

5 A 12a \$6 00

**National Achievement
of Diplomats in recent
years Illuminates our
History with Ambition**

24 POINT

6 A 16a \$5 50

**The Predominant Ideas of
Modern Acquirement are
both Useful and Expedient
to the Oriental Inhabitants**

BRADLEY EXTENDED

18 POINT

10 A 28 a \$5 00

The rich soil and climate of the State of California are notably adapted to the cultivation of the grape. The delicious richness and flavor of California grapes nothing of the fruit kind equals. They grow to a large size in the vineyards and bring \$12

12 POINT

14 A 42 a \$4 00

**Sweet is the pleasure
Itself cannot spoil!
Is not true leisure
One with true toil?**

15 POINT

12 A 36 a \$4 50

The cactus plant grows quickly in this section, and is used for hedging in all places making an impervious barrier against man and beast. The stalks of some of the plants and shrubs are of the thickness of a man's body and grow to the height of sixteen feet. One of the most serviceable and highly useful plants of California is the soap plant. The 3156

**Rest is not quitting
The busy career;
Rest is the fitting
Of self to its sphere.**

BRADLEY EXTENDED

10 POINT

16 A 48 a 83 50

Philadelphia, March 29th, 1898.**Gentlemen:**

Our salesman, Mr. John Young, will call on your firm on or about the first of next month with a full line of goods for the Fall and Winter Trade. We have added a fine line of inexpensive Parisian Novelties of which we will mail you a few samples. Chanking you heartily for past favors, and hoping for a continuance of the same, we remain,

Yours truly,**Martin Rober & Co.**

6 POINT

20 A 60 a 83 00

**I met him in the cars,
Where resignedly he sat;
His hair was full of dust,
And so was his cravat;
He was furthermore embellished
By a ticket in his hat.**

**The conductor touched his arm,
And awoke him from a nap;
When he gave the feeding files
An admonitory slap,
And his ticket to the man
In the yellow-lettered cap.**

**The heads of many men
Were bobbing as in sleep,
And many babies lifted
Their voices up to weep;
While the coal-dust darkly fell
On bonnets in a heap.**

**All the while the swaying cars
Kept rumbling o'er the rail,
And the frequent whistle sent
Shrieks of anguish to the gale,
And the cinders pattered down
On the grimy floor like hail.**

8 POINT

16 A 50 a 83 25

**Office of
Washington Excursion Bureau,
No. 47 First Avenue.**

January 21st, 1901.

In obedience to the wishes of our many patrons and the general public, a Chaperone will accompany each one of our Personally Conducted Summer Tours during the forthcoming season. This new innovation will be highly appreciated by parents desiring to send young children.

For detailed account of trips, rate of fare, and other useful information, write to

**William Valentine Brown,
General Manager.**

BRADLEY SERIES

60 POINT

3 A 5 a 88 50

Leads the Style
in Black Letters

48 POINT

3 A 8 a 86 75

Early printers were
loud in their praise

36 POINT

4 A 10 a 85 00

Gothic went out of fashion
in Germany and France at
the end of the 16th century

Bradley Outline, registering with this series, is shown on page 432

BRADLEY SERIES

24 POINT

5 A 16 a \$3 50

GERMAN printers of 1450 used bold Black Letters so that they could avoid detection in their many undertakings of a hazardous nature

18 POINT

8 A 25 a \$3 25

THE pages of early books were either large or small folios, but sometimes quartos, and were therefore cumbrous and unhandy. • Aldus Manuccio, of Venice, was the first to introduce the

12 POINT

15 A 45 a \$3 00

EXTON was over sixty years of age when *The Dices* was printed and was notable for his industrious habit. He possessed good sound

10 POINT

16 A 50 a \$2 75

FAUST and Schaeffer printed the Bible, Psalter and other important works. From this rapid summary we may conclude: 1. That the merit of the invention of the art of printing, however rude it may

8 POINT

18 A 52 a \$2 50

Gutenberg continued printing at Strasburg until the year 1444, when, his means being exhausted, he rejoined his uncle at Mentz. Here he renewed his experiments, and, as he needed financial assistance, secured an introduction to John Faust, a money-lender

6 POINT

20 A 60 a \$2 25

The credit of inventing the art which perpetuates the history and achievements of all the arts and sciences has been obstinately contested, several cities having advanced rival claims to the honor of the discovery. This, however, should be no matter of surprise when we consider that the inventor of any new art, unprotected by law, would naturally endeavor to conceal its process for his own use and advantage. • After due

Bradley Outline, registering with this series, is shown on page 432

54 POINT BRADLEY INITIALS 3 A \$4 25
SINGLE LETTER 25 CENTS

42 POINT BRADLEY INITIALS 3 A \$3 00
SINGLE LETTER 20 CENTS

BRADLEY ITALIC

60 POINT

3 A 5 a \$9 00

*Sound Banker
Receive Drafts*

48 POINT

3 A 7 a \$7 25

*Electrical Winder
Novel Time Clock*

36 POINT

4 A 10 a \$5 50

*Monthly Reports Given
Lombard Insurance Co.*

30 POINT

5 A 12 a \$5 00

*Quakers Welcome Visitors
Unique Patriotic Ceremony*

BRADLEY ITALIC

24 POINT

6 A 18 a \$4 50

Fame and fortune never overtakes men in the day of their discontent

18 POINT

9 A 26 a \$4 00

The perilous rush of Speculators and the Adventuresome Miner to the Gold Fields has been overshadowed by Greater Issues

15 POINT

12 A 36 a \$3 50

Couched in tones of unmistakable patriotism, the Declaration of Independence endowed the people of the United States with privileges of the most far-reaching importance to American citizenship

12 POINT

14 A 40 a \$3 25

The Laws of Progression have marked the closing of the Nineteenth Century as the Age of Wonders. With prospects of still greater attainments in the near future, the best-thinking minds have predicted revolutions in social and political life that will astonish the most conservative

10 POINT

14 A 45 a \$3 00

Pride and humility are relative terms. They suggest a comparison of some sort with an object higher or lower; and the same mind may be proud

1 2 3 4 5 6 7 8 9 0

8 POINT

16 A 48 a \$2 75

Of two minds that possess equal excellence, which is the noblest: that which, however high the excellence attained by it, has some nobler excellence in view; or that which thinks only of those who

1 2 3 4 5 6 7 8 9 0

BRADLEY OUTLINE

60 POINT

3 A 5 a \$8 50

Leads the Style

48 POINT

3 A 8 a \$6 75

Early printers were

36 POINT

4 A 10 a \$5 00

Gothic went out of fashion
in Europe towards the end

24 POINT

5 A 16 a \$3 50

German Printers of 1450 used bold
Black Letters to avoid being detected

18 POINT

6 A 25 a \$3 25

Pages of early books were either large or small
folios, but sometimes quartos, and were there-
fore cumbrous and unhandy • Aldus Manuccio

TWO-COLOR TYPE STYLES

48 POINT COLUMBUS NO 2 AND COLUMBUS OUTLINE

EACH 3 A 5a \$9 35

Mountain

FOR OTHER SIZES SEE PAGES 310 AND 311

60 POINT EREBUS (SOLID) AND HADES (OUTLINE)

EACH 4 A \$5 75

ELEVATORS

FOR OTHER SIZES SEE PAGE 323

48 POINT BRADLEY AND BRADLEY OUTLINE

EACH 3 A 8a \$6 75

Robust Master

FOR OTHER SIZES SEE OPPOSITE PAGE

60 POINT LIVERMORE AND LIVERMORE OUTLINE

EACH 3 A 4a \$8 25

Housewives

FOR OTHER SIZES SEE PAGE 321

Printed with Nathan's Fine Union Black F, per pound, \$3.00; Persian Yellow, per pound, \$2.00; Tint No. 3, per pound, \$1.00. Prices subject to liberal discount.

TWO-COLOR TYPE STYLES

48 POINT DEVINNE AND DEVINNE SHADED

EACH 4 A 5 a \$7 75

Rare Mine

FOR OTHER SIZES SEE PAGE 506

36 POINT MULTIFORM No 1 AND MULTIFORM No 2

EACH 4 A \$4 25

ENHANCED

FOR OTHER SIZES SEE PAGE 511

36 POINT MULTIFORM No 1 AND MULTIFORM No 3

EACH 4 A \$4 25

NOVELTIES

FOR OTHER SIZES SEE PAGE 511

48 POINT DEVINNE ITALIC AND DEVINNE ITALIC OUTLINE

EACH 4 A 5 a \$7 75

Bold King

FOR OTHER SIZES SEE PAGES 304 AND 305

36 POINT MULTIFORM No 1 AND MULTIFORM No 4

EACH 4 A \$4 25

PURCHASE

FOR OTHER SIZES SEE PAGE 511

*Printed with Nathan's Fine Union Black F, per pound, \$3.00; Geranium Lake, light, per pound, \$5.00; Chrome Yellow, light, per pound, \$2.00.
Prices subject to liberal discount.*

TWO-COLOR TYPE STYLES

48 POINT ERRATICK AND ERRATICK OUTLINE

EACH 4 A 5a \$7 50

Executors

FOR OTHER SIZES SEE PAGE 319

60 POINT SATANICK AND SATANICK OPEN

EACH 4 A 5a \$12 25

Bark Sold

FOR OTHER SIZES SEE PAGE 420

60 POINT VIRILE AND VIRILE OPEN

EACH 4 A 6a \$7 50

Consideration

FOR OTHER SIZES SEE PAGE 317

60 POINT BINNER AND BINNER OPEN

EACH 4 A 5a \$12 25

Matches

FOR OTHER SIZES SEE PAGE 327

Printed with Nathan's Fine Union Black F, per pound, \$3.00; Geranium Lake, light, per pound, \$5.00; Chrome Yellow, light, per pound, \$2.00. Prices subject to liberal discount.

CAXTON BLACK

54 POINT

3A 5a 87 80

Ancient Scribe Rich and Wise

6 POINT

14A 45a 81 75

The Hero's Death

Life's parting beams were in his eye,
 Life's closing accents on his tongue,
 When round him, pealing to the sky,
 The shout of victory rung:
 E'en, ere his gallant spirit fled,
 A smile so bright illumed his face—
 Oh! never, of the light it shed,
 Shall memory lose a trace!

His was a death whose rapture high
 Transcended all that life could yield;
 His warmest prayer was so to die,
 On the red battle-field!
 And they may feel, who loved him most,
 A pride so holy and so pure—
 Safe hath no power o'er those who boast
 A treasure thus secure!

42 POINT

3A 9a 85 10

Penthesilean Benefactor Tenders Highest Award

[HISTORICAL NOTE.—Caxton Black is a reproduction of the chief type made and used by WILLIAM CAXTON, the first English printer. He finished his first book, "The Dictes and Sayings of the Philosophers," A. D. 1477. This paragraph is set in *Caxton Old Style*, cut by WILLIAM CASLON, A. D. 1722. *Caxton Old Style*, *Caxton Black* and *Privity Text*, all shown in this book and exclusively made in America by the American Type Founders Company, are the most ancient type faces now in use in English speaking countries.]

Printed with Nathan's Fine Union Black F, per pound, \$3.00; and Nassau Lake, per pound, \$4.50.
 Prices subject to liberal discount.

CAXTON BLACK

30 POINT

4 A 12 a \$3 80

Children Eagerly Listen to the
Beautiful Strains of the Violin
while its Echoes are Resounding

12 POINT

10 A 30 a \$2 35

The Bird at Sea

Bird of the greenwood,
Oh! why art thou here?
Leaves dance not o'er thee,
Flowers bloom not near.

All the sweet waters
Far hence are at play—
Bird of the greenwood,
Away, away!

Where the mast quivers
Thy peace will not be,
As 'midst the waving
Of wild rose and tree.

9 POINT

10 A 30 a \$2 15

Fairies' Recall

While the blue is richest
In the starry sky,
While the softest shadows
On the greenward lie,
While the moonlight slumbers
In the lily's urn,
Bright elves of the wild wood,
Oh! return, return!

Round the forest fountain,
On the river shore,
Let your silvery laughter
Echo yet once more!
While the joyous bounding
Of your dewy feet
Rings to that old chorus:
"The daisy is so sweet!"

18 POINT

6 A 18 a \$2 75

Music is the living source of all social pleasures; it soothes Violent Impulses of Man, dignifies Religious and Civic Ceremonies, and educates the æsthetic taste of the human family

PRIORITY TEXT No 2

36 POINT

6 A 8 a \$6 00

**Bankers Daughter
Saved from the Enemy
Grand Theatre**

30 POINT

6 A 10 a \$5 00

**William S. Chanfrau
Kit, the Arkansas Travellers
Bijou Opera House**

18 POINT

8 A 20 a \$4 00

**Three Guardsmen, Two Orphans
The Milkwhite Flag, and Telephone Girls
Conservatory of Music**

12 POINT

8 A 24 a \$3 10

**Richard Mansfield Alone in New London
Midsummer Nights Dream on the Streets of New York
1 2 3 4 5 6 7 8 9 0**

PRIORY TEXT No 1

14 POINT

8A 24 a \$3 64

All Photo-Engravings are produced by means of photography. It is a fact worthy of note that experimenting in photographic engraving gave rise to photography itself. The aim of Niepce, when he began his researches, was not only to fix the image he obtained by the camera obscura upon a metal plate,

12 POINT

12A 32 a \$3 08

But to convert this plate into an engraving which could be used on a printing press; but his early death prevented perfecting the process to which he had devoted much time and study. From that time experimenting has been continued by several others, and the result is the production of a number of different processes. A popular one is the swelled gelatine process, though handling 2168

10 POINT

16A 40 a \$3 42

This method of engraving has an advantage over wood engraving in the matter of cheapness; but it has counterbalancing disadvantages, and there are many subjects in which wood engraving surpasses all methods of process engraving. To reproduce a drawing for printing purposes, the picture should be formed of clean, sharp, and very black lines or dots on perfectly white paper. Flat tints and washed or blurred shadows will not answer, unless they are first translated into lines or stipple. Where an engraving is to represent machinery, the 13579

8 POINT

16A 44 a \$3 00

Object is photographed twice the size the plate is to be when finished. The photograph, or silver print, as it is technically called, on which the drawing is to be made, is not toned, but simply fixed in a fresh fixing bath, and then thoroughly washed and dried. It is now ready for the artist, who, with pen and suitable ink, draws directly on the silver print, portraying in delicate lines and dots the lights and shadows of the photograph. After the drawing is complete the photograph is bleached, by pouring upon it an alcoholic solution of bi-chloride of mercury, leaving the ink lines of the artist on clean white paper. The advantage of this method of drawing is at once apparent. The artist has the advantage of working directly on and over

BLACK No 12

36 POINT

3 A 6a \$6 34

Boston Herald
South Acton Globe
Daily Times

30 POINT

4 A 6a \$4 69

London Telegram
Camden Weekly News
Denver Union

24 POINT

4 A 10a \$4 64

American Stamp Review
Memphis Tri-weekly Advertiser
Engraver and Printer

12 POINT

10 A 28a \$3 90

Consuming the Output of 257 Paper Mills
Circulation Beyond the Limit of Figurative Expression
Advertising Rates Merely Nominal

ANGLO-SAXON No 20

60 POINT

3 A 4 a \$8 00

Graphic Sketch

48 POINT

3 A 5 a \$5 50

New Tin

36 POINT

3 A 5 a \$4 00

Young Boy

28 POINT

4 A 9 a \$3 50

Shining Morn

22 POINT

4 A 13 a \$3 00

Cheering the Winner

18 POINT

6 A 16 a \$2 75

Wonderful Predestinators

12 POINT

8 A 20 a \$2 50

Magnificent Land Enterprise

AUGUSTAN TEXT

24 POINT

6 A 14 a \$5 17

Newspaper Publishing Companies

18 POINT

8 A 16 a \$4 49

Europeans Manufacture Christmas Specialties

12 POINT

8 A 24 a \$3 34

Dramatic Corporation
Grandest Theatrical Product

10 POINT

10 A 40 a \$3 02

Mountain Climber Descending
Experienced Guide Smoking Cigarettes

8 POINT

20 A 40 a \$3 06

Another German Warbling Society
Elegant Concerts and Laughable Masquerades

6 POINT

20 A 70 a \$2 93

Responsible Astronomers Cause Excitement
Telegraph Operators Refusing Corporation Dividends

1 2 3 4 5 6 7 8 9 0

1 2 3 4 5 6 7 8 9 0

TUDOR BLACK

72 POINT

3 A 5a \$12 00

Dark Echo

48 POINT

5 A 8a \$8 50

Umpires
Eight and Ten

40 POINT

4 A 12a \$6 00

Home Run
Stole the Games

36 POINT

4 A 12a \$5 50

Divide Among
Grand Stand Money

TUDOR BLACK

24 POINT

5 A 15 a \$4 75

**Eminent Censure
Award Genius Sparingly
Nation Proves**

20 POINT

5 A 15 a \$3 50

**Following Afterwards
Reputation is Like the Shadow
Preceding Before**

18 POINT

8 A 25 a \$3 40

**Sometimes, but Not Always
Accidents that Pass for Misfortunes
Return to our Welfare**

12 POINT

9 A 30 a \$2 75

**Quicken Movement
The Depletion of Purse
Dead Sure Thing**

10 POINT

12 A 36 a \$2 75

**Photographs Hanging
Obscure Way Unfavorable
Electric Lights**

8 POINT

15 A 50 a \$2 75

**Blockheads are Stubborn
Wise People Change Their Minds**
1 2 3 4 5 6 7 8 9 0

6 POINT

15 A 50 a \$2 25

**Ambition is Pronounced a Lottery
Censure is the Tax a Man Pays to the Public
for being Eminent. Don't all Speak at Once!**
1 2 3 4 5 6 7 8 9 0

TITLE BLACK SERIES

36 POINT

3 A 6 a \$6 10

Free Lance
Unfettered Press

24 POINT

4 A 8 a \$4 45

Public Speakers
Time-Honored Customs

18 POINT

5 A 10 a \$3 40

Moonlight Association
Uncertainty of Forked Lightning

12 POINT

7 A 16 a \$3 00

Full Game Bags
National Coon Hunt
Great Victory

10 POINT

8 A 20 a \$2 85

Temperate Customs
Guarantees of Longevity
Fourscore Years

8 POINT

8 A 20 a \$2 70

Hills and Valleys
Mountain Summer Jaunts
Dining in the Woods
1 2 3 4 5 6 7 8 9 0

6 POINT

10 A 28 a \$2 50

Microscopic Revelations
Voyages Through a Drop of Water
Customs of the Inhabitants
1 2 3 4 5 6 7 8 9 0

BOSTON BLACK SERIES

36 POINT

3A 4a \$4 50

Latest Modern Book

28 POINT

4A 8a \$4 00

Discounted Bank Checks

22 POINT

4A 10a \$3 50

Roast Turkey and Mince Pies

18 POINT

5A 14a \$3 00

New Mexico Board of Public Directors

12 POINT

5A 18a \$2 75

Discussions on Printed Business Catalogues
1234567890

PARISIAN BLACK No 120

24 POINT

5A 12a \$5 30

Manhattanville Telegraph

18 POINT

5A 12a \$3 80

Unparalleled Industrial Alliance

12 POINT

6A 16a \$3 40

**Distinguished
American Writers**

10 POINT

8A 24a \$3 25

**Fair Aristocratic
Heartbroken Widows**

8 POINT

8A 24a \$2 75

**Startling Diplomatic
Transactions Investigated**

6 POINT

10A 30a \$2 75

**Picturesque Landscapes
Beautiful Rural Summer Resorts**

YONKERS SERIES

48 POINT

3 A 8 a \$6 95

Oriental Stream

36 POINT

4 A 8 a \$4 50

Gallant Tribe Leaders

30 POINT

5 A 10 a \$3 85

Southern Chivalry
Truly Proverbial Beauty

22 POINT

8 A 15 a \$3 45

Local Taxes
Helpless Victim

14 POINT

10 A 20 a \$2 30

Combined Efforts
General Task System

12 POINT

15 A 25 a \$2 30

Reactionary Movement
Partisan Doctrines Exploded

10 POINT

20 A 30 a \$2 25

Prosperous Legislators
Pandemonium Reigns Supreme

8 POINT

25 A 40 a \$2 10

Society for the Suppression of
Independent Thought among Bachelors

6 POINT

30 A 50 a \$2 15

Professional Philanthropic Reformers
Inconsistent Preachers and Impractical Teachers

1234567890

1234567890

HAMBURG SERIES

28 POINT

5A 12a \$4 45

Eight Blooming Rosebud

24 POINT

5A 20a \$4 35

Achieved Success
Persistent Washingtonians

22 POINT

6A 20a \$3 50

Exquisitely Flavored
Fancy Mecklenburg Horseradish

18 POINT

10A 20a \$3 70

Eschewed Absurd Notions
Medieval Connoisseurs Excellent Taste

14 POINT

15A 25a \$3 30

Often Take Place in Nature
Periodic Transitions from Mountain to Valley

12 POINT

15A 30a \$2 85

International Favorites
Become Established Faces

10 POINT

15A 30a \$2 50

Developments Outstride
Time in the Art Preservative

8 POINT

20A 40a \$2 45

Fashions in Printing Types
Multiply Each Succeeding Season
1234567890

6 POINT

30A 50a \$2 35

American Enterprise Produce Every
Imaginable Device for the Saving of Labor
1234567890

GRAPHIC TEXT

36 POINT

3A 5a \$4 55

Commercial and Meritorious

24 POINT

5A 10a \$3 95

Waving Flowers
1234567

18 POINT

6A 14a \$3 60

Beautiful and Historical
12345678

RIPPLE TEXT

36 POINT

5A 10a \$6 95

Fourteen Senoritas Romping

24 POINT

6A 14a \$5 15

Theatre Managed
1234567

18 POINT

6A 18a \$3 95

Destructive Explosives
1234567890

QUEEN ANNE TEXT

36 POINT

3A each style 6a \$7 35

Strikingly Handsome Chrysanthemums

24 POINT

4A each style 10a \$4 65

Bathing in Atlantic Ocean
123456789

18 POINT

6A each style 20a \$4 60

Explanation of Postprandial Witticism
1234567890

TITLE SCRIPT

48 POINT

4 A 12 a \$12 10

Annual Excursion
Editors First Convention
Hammond 63 Indiana

32 POINT

Circular Font 5 A 25 a \$10 50
Card Font 3 A 8 a \$4 75

True Scenic Grandeur
Boston Excursion Association will
again visit Lake Champlain with a
Number of very Select People 214

24 POINT

Circular Font 8 A 50 a \$11 45
Card Font 4 A 12 a \$4 00

Great Unselfishness of Conduct
Among all the Accomplishments of Life none
Is so important as Refinement; Unlike beauty,
Nature is not its Parent. By Cultivation 795

LACLEDE SERIES

72 POINT

3 A 5 a \$12 00

Monumental

60 POINT

3 A 6 a \$10 00

Broken Dishes

48 POINT

4 A 7 a \$8 00

Country Residence

36 POINT

4 A 9 a \$6 25

Unique Pictures Framed

24 POINT

5 A 14 a \$4 00

*Industrious
Western Farmer*

18 POINT

5 A 18 a \$3 25

*Enchantment
Handsome Decoration*

12 POINT

7 A 24 a \$3 00

*Financial Speculation
Renowned European Negotiators
1 2 3 4 5 6 7 8 9 0*

10 POINT

9 A 30 a \$2 75

*Journalistic Conventions
Neapolitan Newspapers Represented
1 2 3 4 5 6 7 8 9 0*

NOVELTY SCRIPT

72 POINT

3 A 4 a \$16.00

Rich Child

60 POINT

3 A 5 a \$11.75

Love's Dream

48 POINT

3 A 6 a \$9.00

Famous Battles

36 POINT

4 A 8 a \$7.25

Lithographic Printing

24 POINT

5 A 12 a \$5.25

*Pay to the Order of Thomas Little
Sixteen Kicks with Heavy Boots*

18 POINT

5 A 16 a \$4.00

*It Has Always Been Observed to be a Fact
"Truth Crushed to Earth Shall Rise Again"*

1234567890

ROYAL SCRIPT

30 POINT No 1

Circular Font 7 A 20 a \$9 00
Card Font 4 A 10 a \$5 00

*Men are always helpful through the
Intellect and the Affections. Other
Help I find is a false appearance.
If you affect to give me bread 127*

30 POINT No 2

Circular Font 7 A 22 a \$9 00
Card Font 4 A 12 a \$5 00

*Man regards his century or his Half-
Century as the culmination of Light, as
a Festival-day, to which all other centuries
Lead only as week-days. He can 1898*

24 POINT No 1

Circular Font 8 A 20 a \$7 50
Card Font 4 A 10 a \$4 50

*Reading is well Compared to the Filling
of a Granary with grain, and thinking to
Nothing but Sowing the seed. We should
Always weigh and consider, not contradict.
Meditation is active; reverie, idle thought 35*

ROYAL SCRIPT

24 POINT NO 2

Circular Font 8 A 22 a 87 50
Card Font 4 A 12 a 84 50

Among all the Accomplishments of Life none is so Important as Refinement; Unlike beauty, Nature is not its Parent. By Cultivation and Everlasting practice only can it be acquired 467

18 POINT

Circular Font 8 A 24 a 86 00
Card Font 4 A 12 a 83 50

The moral Character that any Person has attained at thirty-five years is as permanent as the intellectual. If he has been pursuing the Noblest Aims, he will continue to Follow them for the Rest of his Life, and they will Become more Deeply Imbedded in his Character 350

12 POINT

Circular Font 10 A 32 a 85 00
Card Font 5 A 16 a 83 00

By Christianity a Moral motive-power is Supplied, which is Far better than any fact or Enactment in Keeping society together: And that is, the charity that is not easily provoked, the love that works no Ill to any of his Neighbors. To the motives which tend to Insure Well-being in this world it adds loftier Hopes, the nobler Aspirations, the better Purposes, that blind the Christian to an endless future. It helps him to be a Better citizen 192

10 POINT

10 A 32 a 84 50

Beloved, the Earth is to-day so beautiful! that, indeed, makes Man more Tender; the Heavens rest with a Caress and Kiss of Love on the Earth as a Father on a Mother on her Children. The Flowers and beating Hearts fall into the embrace and nestle around the Mother; the Twig gently Rocks its Finger up and down, the leaf cradles its fly, the Flower its bee and its Drop of Honey; in the open flower-cups hang the warm Tears into which the Clouds dissolve themselves, as if in Eyes 1875

ROYAL SCRIPT

30 POINT No 1

Circular Font 7 A 20 a 89 00
Card Font 4 A 10 a 85 00

*Men are always helpful through the
Intellect and the Affections. Other
Help I find is a false appearance.
If you affect to give me bread 127*

30 POINT No 2

Circular Font 7 A 22 a 89 00
Card Font 4 A 12 a 85 00

*Man regards his century or his Half-
Century as the culmination of Light, as
a Festival-day, to which all other centuries
Lead only as week-days. He can 1898*

24 POINT No 1

Circular Font 8 A 20 a 87 50
Card Font 4 A 10 a 84 50

*Reading is well Compared to the Filling
of a Granary with grain, and thinking to
Nothing but Sowing the seed. We should
Always weigh and consider, not contradict.
Meditation is active; reverie, idle thought 35*

ROYAL SCRIPT

24 POINT NO 2

Circular Font 8 A 22 a \$7 50
Card Font 4 A 12 a \$4 50

Among all the Accomplishments of Life none is so Important as Refinement; Unlike beauty, Nature is not its Parent. By Cultivation and Everlasting practice only can it be acquired 467

18 POINT

Circular Font 8 A 24 a \$6 00
Card Font 4 A 12 a \$3 50

The moral Character that any Person has attained at thirty-five years is as permanent as the intellectual. If he has been pursuing the Noblest Aims, he will continue to Follow them for the Rest of his Life, and they will Become more Deeply Imbedded in his Character 350

12 POINT

Circular Font 10 A 32 a \$5 00
Card Font 5 A 16 a \$3 00

By Christianity a Moral motive-power is Supplied, which is Far better than any fact or Enactment in Keeping society together: And that is, the charity that is not easily provoked, the love that works no Ill to any of his Neighbors. To the motives which tend to Insure Well-being in this world it adds loftier Hopes, the nobler Aspirations, the better Purposes, that blind the Christian to an endless future. It helps him to be a Better citizen 192

10 POINT

10 A 32 a \$4 50

Beloved, the Earth is to-day so beautiful! that, indeed, makes Man more Tender; the Heavens rest with a Kiss of Love on the Earth as a Father on a Mother or her Children. The Flowers and beating Hearts fall into the embrace and nestle around the Mother; the Twig gently Rocks its Finger up and down, the leaf cradles its fly, the Flower its bee and its Drop of Honey; in the open flower-cups hang the warm Tears into which the Clouds dissolve themselves, as if in Eyes 1875

BOSTON SCRIPT

80 POINT 12

12 1

3 A 8 a \$15 00

Bravest victory
gained in battle
by our troops 42

48 POINT 1

4 A 10 a \$12 00

The society will use
the Custer building
until quarters for 27
members are secured.

BOSTON SCRIPT

36 POINT

5 A 15 a \$10 00

You are reminded that the care given to Script type regulates period of usefulness 278

24 POINT

Circular Font 7 A 20 a \$8 00

Card Font 3 A 8 a \$3 00

Measure the existence of perishable or easily injured Articles only after Proper Treatment has been given to them \$34,690

18 POINT

Circular Font 9 A 25 a \$6 00

Card Font 3 A 10 a \$2 00

You are requested to attend the Seventeenth Annual Dance to be given under our auspices in Pythian Hall, on Wilson Boulevard, Thursday evening the 25th of December, 1897. Music, Fusillade Orchestra of Eight

A M N

These extra Capitals are put up separately at the following prices: 48 Point, \$1.00; 36 Point, 75 cents; 24 Point, 50 cents; 18 Point, 50 cents.

AMERICAN SCRIPT

60 POINT

3 A 8 a \$10 00

*Beautiful Invitations
in this Celebrated Script*

48 POINT

4 A 10 a \$9 00

*Elegance and Usefulness for
the Printer are combined in the
Artistic Design of this Series*

36 POINT

5 A 15 a \$8 00

*Compositors and Lovers of good Taste
in Printing will readily Appreciate this
perfect Reproduction of Penmanship*

AMERICAN SCRIPT

30 POINT

Circular Font 7 A 20 a \$7 50
Card Font 3 A 10 a \$4 25

You are Cordially invited to attend a Public Reception in the new Academy of Music in Honor of our Glorious Victories in the War

24 POINT

Circular Font 8 A 22 a \$7 00
Card Font 4 A 11 a \$4 00

In calling the attention of Customers and Friends to our Removal from the Old Stand, we desire to express our Sincere Gratitude for their previous Liberal Patronage

18 POINT

Circular Font 9 A 24 a \$6 00
Card Font 5 A 12 a \$3 50

The New Store will be inaugurated with a Bargain Sale in every Department. We have spared neither money nor labor to make this the Greatest Opening in the History of the City, and we hope that our Patrons will appreciate our motto: Large Sales and Small Profits.

12 POINT

Circular Font 10 A 32 a \$5 00
Card Font 5 A 16 a \$3 00

Some time ago we mentioned that our French Agent, Monsieur Deymarol, had bought at a Very Low Figure the Entire Stock of a large manufacturer of Artificial Flowers. These Flowers were used in Trimming Hats in our own Workshops, and, as we anticipated, they caught the Public Fancy. While lacking nothing of French Dash, Spirit, Originality or Tone, these Reformed Creations of American Millinery have the Advantage of Low Prices

1234567890

STEELPLATE SCRIPT

PATENTED

30 POINT No 1

Circular Font 7 A 20 a \$9 00
Card Font 4 A 10 a \$5 00

*The Excellence of Religion is Shown
By the Fact that Many Pretended
To possess it. The Odorous Balsam is
Easily imitated, because it is so precious
And Fragrant, and Necessarily there
Are many Spurious kinds; But \$639*

30 POINT No 2

Circular Font 7 A 25 a \$9 00
Card Font 4 A 12 a \$5 00

*The Poor man is Hungry and Athirst: but
Even for him there is always Food and Drink;
He is often Heavy-Laden and Weary: but
For him also Heaven sends Sleep, and this of
The Deepest; In his Smoky Cribs, a Clear
Downy heaven of Rest envelops him \$21547*

STEELPLATE SCRIPT

PATENTED

24 POINT NO 1

Circular Font 8 A 22 a \$7 00
Card Font 4 A 12 a \$4 00

*Let Honesty be the Breath of thy Soul, and
Never Forget to have a Penny or Two, when
All thy Expenses are Enumerated and paid;
Then Shalt Thou safely reach the Point of
Happiness, and Independence. Shall be 384*

24 POINT NO 2

Circular Font 8 A 28 a \$7 00
Card Font 4 A 14 a \$4 00

*True Life can never be well Developed among Throngs
And Noises. We must Betake Ourselves into the
Remote desert Places. In a word, we must get away
From Men and View Life from such Distance as
May be Realized by Intimate Divine Fellowmen 576*

12 POINT

Circular Font 10 A 32 a \$5 00
Card Font 5 A 16 a \$3 00

*Ambition, that High and Glorious Passion, which makes such
Havoc among the Sons of Men, Arises from a Proud Desire of
Honor and Distinction, and when all those Splendid Trappings
In which it is usually Caparisoned, are Removed, will be found
To Consist of Mean Materials of Envy, Pride and Covetousness.
It is Described by the Different Authors as a Gallant Madness, a
Pleasant Poison, a Hidden Plague, a Secret Poison, the 12790*

OLD STYLE SCRIPT

30 POINT

Circular Font 6 A 18a \$9 00
Card Font 3 A 9a \$5 00

As the popularity of the old style effects in type designs does not seem to be waning, we know

24 POINT

Circular Font 6 A 20a \$8 00
Card Font 3 A 10a \$4 50

Florence can still ring her belly with the solemn hammer sound that used to beat on the hearts of her citizens and strike out the fire there. And where

18 POINT

Circular Font 8 A 24a \$6 00
Card Font 4 A 12a \$3 50

Life had its zest for the old Florentine when he, too, trod the marble steps and shared in those dignities. His politics had an area as wide as his trade, which stretched from Syria to Britain, but they had also the new

12 POINT

Circular Font 10 A 32a \$5 00
Card Font 5 A 16a \$3 00

Even if, instead of following the dim day-break, our imagination pauses on a certain historical spot and awaits the fuller morning, we may see a world-famed city, which has hardly changed its outline since the days of Columbus, seeming to stand as an almost unviolated symbol, among the flux of human things, to remind us that we still resemble the men of the past more than we differ from them, as now

SPENCERIAN SCRIPT No 2

40 POINT

Card Font 2 A 5 A 25 a \$20 75
Circular Font 4 A 10 A 50 a \$41 50

Meeting for Promotion
Friday Evening, May 7, 1895

28 POINT

Card Font 3 A 8 A 30 a \$16 05
Circular Font 6 A 16 A 60 a \$32 05

Distribution of Greenbacks
This Petition of male inhabitants of the
township of Loafersdom, in the County 563

22 POINT

Card Font 3 A 9 A 50 a \$14 05
Circular Font 6 A 18 A 100 a \$28 05

Lessons in the Arts, and Mysteries of Courtship
Methods for Becoming Fascinating
The commodious Steamer Orange Blossom, expressly
built for our Hymenical trade, will make its 2534

16 POINT

Card Font 3 A 9 A 50 a \$10 35
Circular Font 6 A 18 A 100 a \$20 65

Cabalistic Observances, and Initiations of Members
Every Wednesday and Friday Evening
The Examiners, and Faculty of the University of Teachem-
fast, in the City of Classic Lore, do hereby Certify 7809

The Ornamented Capitals may be used with both Series of Spencerian Script, and may be purchased separately at following prices: 16 Point, O.A. \$2.50; 22 Point, O.A. \$3.50; 28 Point, O.A. \$4.50; 40 Point, O.A. \$5.00.

SPENCERIAN SCRIPT

PATENTED

60 POINT

3 A 9 a \$17 60

Highway Inspectors
 Coast Surveyor
 Water Departments.

40 POINT

 Card Font 5 A 25 a \$20 00
 Circular Font 10 A 50 a \$40 00

Fifth Annual Drive
 Philadelphia to Somewhere.
 Hornblowing at Sunrise,
 on November the 28th, 1903.
 Dinner at Whip Mansion

SPENCERIAN SCRIPT

PATENTED

28 POINT

Card Font 8 A 30 a \$14 40
Circular Font 18 A 60 a \$28 75

M^{rs} Gushington & Daughter
Tender the advantages of their company
during summer vacations to any family
whose rural antecedents were always 762

22 POINT

Card Font 9 A 50 a \$13 65
Circular Font 18 A 100 a \$27 25

This Useful Series of Scripts
Which we call Spencerian, we present to the
attention of Printers in the assured confidence
that it will meet with their hearty approval.
Its elegant appearance is not its only 9073

18 POINT

Card Font 9 A 50 a \$9 15
Circular Font 18 A 100 a \$18 30

This Combination of late Improvements
Is presented for further appreciative consideration. Its
tones are of a magnificent singing quality, of marvelous
volume and strong penetrating power, and in perfect
sympathy with the human voice, while the wave-like
melodies of its softer modulations enchant all by their
purity, increasing the delights of home and enhancing 4672

M^{rs} M^r C^o C^o the U. C. Th. H. V. h

SANSOM SCRIPT

PATENTED

36 POINT

6 A 30 a \$15 00

Profitable Business
Rushlight Manufacturing Co.,
No. 6941 Glimmer St.

24 POINT

10 A 50 a \$12 50

Stockholders, Attention!
Financial necessities compel the Management
to order an assessment on every share of stock of
the Rushlight Manufacturing Company, 230

18 POINT

10 A 50 a \$9 30

Guaranteed Dividends, one Hundred per Cent.
Formation of a new Company
Our facilities for manufacturing Rushlights are excellent,
and, as you are one of our intimate friends, we offer you
the privilege of coming into our corporation on the ground
floor. The par value of our shares is \$96.58, but, if

GROLIER SERIES

PATENTED

24 POINT with 36 Point Initials

3 A 4 A 20 a 87 50

Society to Encourage Industrious Habits

Initiation of Members

*Knowing that the Human Hand, intelligently
educated and skillfully employed, has delivered*

18 POINT with 30 Point Initials

3 A 6 A 30 a 88 90

Meeting for Transaction of Business

Expulsion of Members

*Whereas, on the 15th inst. Peter Fiddlefaddle was found
near the Castle of Indolence, sitting astride a fence, and
there remained whittling a pine stick for a period of*

12 POINT with 24 Point Initials

4 A 8 A 40 a 85 80

Report of Committee on Extension of Usefulness

Recommendations for Future Activity

*In the prosecution of our labors we find many persons lying under
trees expecting fruit to drop into their mouths, others waiting for
something to turn up, numbers lingering around hoping to step into
other people's shoes, some who appear anxious to shovel snow in*

FRENCH SCRIPT

54 POINT

3 A 9 a \$12 20

Pensive Thoughts

44 POINT

4 A 12 a \$11 25

*Homestead Destroyers
Court Litigants*

36 POINT

5 A 14 a \$10 75

*Treatise on Meal Packing
Excursion Steamboats*

28 POINT

6 A 18 a \$8 90

*Truants School-boys
Captured in Bathing Costume
Unadorned Humanity*

FRENCH SCRIPT

22 POINT

7 A 22 a 87 25

*Chicken and Watermelon Thieves
Arrested and Punished
Without aid from the Constable, Judge, or
Jury, and Garden protected with great care*

18 POINT

8 A 24 a 86 00

*Grand Exhibition of Animated Curiosities
Discovered in Queer Places
Captured by M^{iss} Illaqueates, who will explain
hourly the Processes by which they were Bagged
and relate some very Amusing Incidents of them*

14 POINT

9 A 30 a 85 00

*Notice is Hereby Given
M^{iss} Sly is Agent
For our Traps, which are so
very well adapted to catching
Elephants or Millionaires,
Mendicants or Heirefess,
rabid Dogs or the runaway
Apprentice. She explains
all the merits clearly because
her Husband was ensnared
by one of these M^{achines}*

12 POINT

10 A 35 a 84 00

*Profitable Business Opportunity
Good Agents Wanted
Recent Improvements in Delusive
Appliances have made them so near
perfection that fugitive Cashiers and
fraudulent Debtors may be caught
on the wing, Voters entrapped for the
Office-Seeker, a lost Dog recovered,
Subscriptions speedily obtained for
unpopular schemes, and wealthy fools
corraled without the use of a Stool-
Pigeon. Territory in African
Wilds and Siberia still Unoccupied*

LADIES' HAND SCRIPT

32 POINT

Card Font 3 A 8a \$4 50
Circular Font 5 A 25a \$10 00

The Poor man is Hungry and Athirst
But even for him There is always 348

32 POINT NO 2

Card Font 3 A 8a \$4 75
Circular Font 5 A 25a \$10 80

Excellence of Religion is Shown
By the Fact that Many are 170

24 POINT

Card Font 4 A 12a \$4 00
Circular Font 8 A 50a \$10 90

Madame Le Bostonic and Daughter Angelina
Elegant Minutia of Fashionable Etiquette 189

24 POINT NO 2

Card Font 4 A 12a \$4 50
Circular Font 8 A 50a \$12 55

Agricultural Products Exchanged Quickly
Fourteen Dollars and Seven Cents 407

18 POINT

Card Font 6 A 16a \$3 75
Circular Font 10 A 75a \$9 00

Now comes Winter, as Savage as when He met the Ambitious Pilgrims
At Plymouth, Indians all over, a Naked, Splintory Promlook for 325

18 POINT NO 2

Card Font 6 A 16a \$3 75
Circular Font 10 A 75a \$10 75

Reading is well Compared to the filling of a Granary with
Grain, and Thinking of Bathing but Sowing the Seed 94

CARPENTER SCRIPT

30 POINT

Card Font 4 A 16 a \$6 50
Circular Font 8 A 32 a \$12 50

*This Beautiful Script is well
Adapted to artistic Work, 1898*

22 POINT

Card Font 4 A 16 a \$4 50
Circular Font 8 A 32 a \$8 50

*Summer Excursions to the Lake Resorts
rendered safe and pleasant by our steamers
Making daily Trips to and from the 6530*

CLEVELAND SCRIPT

24 POINT

Card Font 4 A 16 a \$4 50
Circular Font 8 A 32 a \$8 50

*We here present for your approval the
scheme of every Loyal Sir Knight
contributing to the Relief Fund 2568*

MAGNOLIA SCRIPT

24 POINT

7 A 20 a \$7 00

*Caesar had made a Will, and that will was
Produced and Read to the people. It was of
A character to Shame his Enemies, and to
Make his Friends more indignant 1234567*

CIRCULAR SCRIPT

PATENTED

24 POINT

10A 50a \$18 65

Actuated by philanthropic motives, we determine to devote our fortunes and the labor of life to the benefit of mankind

18 POINT

10A 50a \$12 20

Rubhard Lively, M. D.

Dear Sir:—I am troubled with Weakness of the Back and an Indisposition to Labor. If you can cure me of this disease you will receive the lasting gratitude of

Yours truly,

Gregory Lackthrift

12 POINT

10A 50a \$7 00

Gregory Lackthrift.

Dear Sir:—Having carefully studied all the symptoms of your Case, I have forwarded to your address a package of superior Elbow Grease, which, if diligently and perseveringly applied, from 7 a. m. to 6 p. m., daily, will relieve your troubles. To prevent a recurrence of the disease, Industrious Habits must be formed, and exercise of a quickstep character freely indulged in

Rubhard Lively, M. D.

MANUSCRIPT No 1

24 POINT

6A 22a 87 00

The armies of the Russian Czar numbered in all but five hundred and seventeen thousand men, while those sent forward to resist him consisted

1 2 3 4 5 6 7 8 9 0

16 POINT

10A 44a 86 00

The battle of Talavera, and the battle of Wagram, under the walls of Vienna, were events of the year that the sad and heart-breaking separation of Napoleon and Josephine took place, by mutual consent, which nearly

1 2 3 4 5 6 7 8 9 0

MANUSCRIPT No 2

24 POINT

6A 20a 87 00

Napoleon marched his army into the Dominion early in June, arriving at Wilna, very hungry

16 POINT

10A 40a 86 00

Shortly after the burial of Sir John, as soon as arrangements could be completed, the fleet sailed from Corunna toward their home, only to meet with misfortunes on the dark waves.

DEVENS SCRIPT

12 POINT

12 A 30 a 84 25

Rubhard Sively, M.D.
64 Ash Street

Malden, August 25, 1898.

Gregory Backthrift,

Dear Sir:—Having carefully studied all the symptoms of your case, I have forwarded to your address a package of superior Elbow Grease, which, if diligently and perseveringly applied, will relieve your troubles. To prevent a recurrence of the disease, industrious habits must be formed, and some exercise of a quickstep character freely indulged in.

Rubhard Sively.

18 POINT

8 A 24 a 84 50

Latest New Character Script
In Five Sizes

This is a reproduction in type of the handwriting of the Rev. Richard M. Devens. In cutting the various letters, absolute fidelity to the original penmanship of Mr. Devens was adhered to, even when in so doing the taste of the Type Founder was violated, and the result is a most delightful symphony in type.

1 2 3 4 5 6 7 8 9 0

DEVENS SCRIPT

10 POINT

16 A 40 a \$4 00

*Brown & Ferguson,
Attorneys and Counsellors at Law,
Court Square.*

Boston, September 20, 1898.

Gentlemen:—In our circular recently mailed you we attempted a review of the business as carried on by the late firm, giving them due credit for what they have done, and without any intention to belittle their efforts. But the best intentions are often misconstrued, and sometimes intentionally. We see no objection to a fair, open criticism of the facts in the letter, should anyone feel it incumbent upon him to do so and to think that any good would come of it. It is deemed necessary to call a Special Meeting for Tuesday, October 9.

Respectfully yours,

Brown & Ferguson.

6 POINT

20 A 50 a \$3 50

*I sit by the fire this cold winter morning,
The red coal lies under, and on the top lies
A log of green hickory, that sings in its burning,
So a martyr might sing as he mounts to the skies.*

*The red coal lies under—great lumps of bitumen,
One cheek in the dawn and one in the night,
From their own substance feeding the flame they consume in,
They die, and in dying give being to light.*

*So—so would I perish. No matter what life is:
Be it in the forest, be it in the mine!
If life and if song the ripe fruit of its strife is,
The flame-eaten heart is becoming divine.*

8 POINT

18 A 44 a \$3 75

*Headquarters
Ladies Dress Reform Club
Quincy.*

In pursuance of resolutions adopted at the November meeting, members will hereafter, when they visit places of public amusement, refrain from wearing bonnets and hats decorated with high-soaring plumes or flowers. The bald-headed fraternity has at last made a successful protest, and the State Legislature has decided that all headgear which will obstruct the view must be removed.

Per order Directors,

Mrs. Newfashion, Secretary.

SCRIPT No 9

28 POINT

8 A 20 a 87 65

Manual for Defaulters
 Questions on the Practice of Incognito
 Route-Book to Leckulationville
 1234567890

22 POINT

12 A 32 a 86 70

Clothiers of the Sovereign People
 Snipper Cutemwell, Pantaloon Snugfit and Associates
 Contractors for Habiliments for Dudedom
 1234567890

18 POINT

12 A 32 a 84 95

Sharp Practice Association of Gotham
 Semi-Occasional Distribution of Valuable Unincumbered Property
 Promises Deferred Maketh the Heart Sick

12 POINT

12 A 32 a 83 40

Cacoutchouc's Patented Extension Apparatus
 Useful in Cases of Emergency. Omnibuses and Bedsteads Enlarged at Pleasure
 Further Particulars given on Application
 Patent-rights for Unlimited Territory Granted to Firstcomers

MASTER SCRIPT

PATENTED

36 POINT

3 A 4 A 12 a 811 90

Artistic Fancy
Certificate of Behavior

24 POINT

3 A 5 A 20 a 88 40

Printing with Economy
Quaintly Harmonizing Letters

18 POINT

3 A 5 A 25 a 86 30

Adornment of Typography
Fanciful Conceits Eagerly Welcomed

12 POINT

10 A 50 a 85 20

Managers of Business Enterprises
Recognize in the Printing-press and other Appliances
Helpmates toward Prosperity
1 2 3 4 5 6 7 8 9 0

B C E F K L M N P R W X Y

Extra letters of the lower-case are furnished to fit the mortise. The Mortised Initial Capitals are cast on the same body as the lower-case, and do not require justification.

SHEPARD SCRIPT

48 POINT

4 A 8 a \$8 00

President ^{and} Secretary
meet Directors May 23

36 POINT

5 A 12 a \$6 75

The National Bank of Silverton
declares Annual Dividend \$580

24 POINT

6 A 18 a \$4 75

Financial Management Reported Competent
to invest the Securities of Stockholders in gilt-
edge Enterprises paying a good percentage 852

18 POINT

8 A 18 a \$3 75

Deposits and Valuable Documents Secured in the very Latest
Improved Fire and Burglar Alarm Vaults. Interest at the
rate of three per cent. allowed on Deposits not exceeding \$8360

QUINCY SCRIPT

48 POINT

3 A 6 A \$6 00

We understand the bird
of Freedom though 5678

36 POINT

4 A 9 a \$5 00

So we have the British Lion,
Russian Bear, American Eagle

24 POINT

5 A 16 a \$4 25

It is customary, even at the present time, to
represent Governments by Symbols which have

AUTOGRAPH SCRIPT

24 POINT

7 A 16 a \$8 00

Experience has proven that the
trade Apprentice foreshadows the
Workman just as surely as 123456

VERTICAL WRITING

24 POINT

7A 22a \$6 00

This is twenty-four point Vertical Writing, originated by American Type Founders Company, sole makers

1 2 3 4 5 6 7 8 9 0

18 POINT

8A 25a \$4 75

The system of Vertical Writing is Finding Advocates in all Parts of the Country, and is being adopted in European educational circles as well. Young people Learn Rapidly when they are Taught this System

1 2 3 4 5 6 7 8 9 0

12 POINT

10A 35a \$4 00

When, in the Course of Educational Events, the System of Vertical Writing becomes the Standard of Teaching in Public Schools, the Printer should provide himself with Types of that Standard. In this Connection it is perhaps superfluous to state that these are the Types. Further remarks unnece

1 2 3 4 5 6 7 8 9 0

CURSIVE SCRIPT

18 POINT

10 A 40 a 26 00 EXTRA LOWER CASE 23 25

Hon. Frederick Sherman:

You are cordially invited to be present at the second of a series of entertainments, given under the auspices of the Worcester Tennis Club, at the residence of Mr. Christopher J. Stapleton, No. 64 Elmwood avenue, Lynn, Monday evening, February 2, 1898.

During the evening Brother Quaintly will explain the advantages gained by adopting Wingston's new labor-saving racket, quite recently outlawed by the ladies

The Worcester Tennis Club.

FRENCH OLD STYLE No 2 ITALIC

10 POINT

20A 50a \$3 00

In the earlier years of his life the parents of Horace E. Walker moved to Claremont, N. H., thence to Brooklyn, N. Y., the father returning to that place from a short stay in California. From thence the family returned to Claremont, at which place the author's poetic labors have since been performed. Come of poor parents his educational advantages were small, he not having attended school since he was about sixteen years of age; and his best work was mostly composed in a cotton factory while tending the Slasher so often referred to in his poems. But not till after he had reached the age of twenty-four did he attempt poetry. And strange enough, the "Lady's Cabinet of Polite Literature" was the star-book of his poetic career, which having been published in 1808, was enchanting to the view.

ROBERT BURNS
AND HIS
HIGHLAND MARY

14 POINT BELZEVIR ITALIC

16A 36a \$3 00

On August 9, 1852, a child was born at Charlestown, N. H., who, Burns-like, was to eke out a precarious and uncertain poetic existence in the coming years. You see the little gable-roofed house where he was born at the foot of the long hill, with its ancient moss-covered watering trough, just on the outskirts of the historic town. It stands there to-day in its unassuming simplicity, with but slight marks of age, though nearly half a century has passed since its birth there.

THE LADY
OF DARDALE

FRENCH OLD STYLE No 2 ITALIC

8 POINT

24 A 60 a 83 75

We now come to the commencement of the third period of Grecian history, at which time the Grecians became intermixed with the Persians in their late history. Darius, son of Hystaspes, being in possession of the Persian throne, resolved to conquer the Greeks, and bring their territory under his immediate control. He therefore sent his army, under the command of his most able officers, into Greece, and the Persians were so sure of success that they carried

THE
WORLD'S
GREAT
EMPIRES

6 POINT

20 A 45 a 82 25

ARISTIDES WAS A STRONG CONTRAST TO THEMISTOCLES, and appeared everywhere to oppose his corrupt principles. He was a man of true and noble character, straightforward and upright in all his deportment. He would not sacrifice principle to favor his best friend; and because of these excellent traits of character he was called Aristides the Just. Aristides was banished from Greece at one time, through the influence of Themistocles, who wanted to be rid of his constant reproof, and when the people came to vote for his banishment, as was customary, the name of the accused was written upon a shell. A peasant who could not write, and who did not know Aristides personally, approached a stranger and requested that he would write the name of Aristides upon his shell; when the stranger asked: "Why do you vote against him; has he done you any wrong, that you are anxious to condemn him?" "No," replied the peasant, "I do not even know him; but I am tired and angry with hearing him called 'The Just.'" Then that stranger took the shell, and wrote the name Aristides upon it, and quietly and courteously returned it to the peasant. That stranger was Aristides himself.

the Persian soldiers came in contact with such men as Themistocles, Aristides, Miltiades, and many others of considerable note, distinguished for their courage and valor—who were prepared to resist them, and to defend their country. It is well to notice the character of these prominent men as they come before us in this capacity, and, in doing so, we shall see that they were not unlike men of our own times. The two first mentioned, Themistocles and Aristides, were a perfect contrast in their principles of life.

12 POINT

16 A 40 a 83 50

wealth and considerable influence, which he used for that purpose. He favored those who would favor him in return; like some men of to-day. About election time there are often those who are ready to grant favors in order to secure the desired object. Their money is made to flow freely, and their affability is most remarkable. This was characteristic of Themistocles. 123456

Themistocles, though having great ability, was always working especially for his individual interest. He loved office, and was ready to do anything that would insure his election to an official position. He had great

THE
ARMY
OF
VALOR

HARVARD ITALIC

30 POINT

6 A 12 a 84 25

PORTLAND BANQUET
Ended in Gayeties
There is considerable pleasant anticipation of the time

24 POINT

7 A 15 a 83 50

HANDSOME TURNOUTS
Old Orchard, August 26
This picturesque resort, famous for its hospitality, its red berries and its pretty girls, opened its gates to-day.

18 POINT

10 A 18 a 83 25

GRAND COACHING PARADE
Greeted with Mighty Cheers
The coaching parade exceeded the most sanguine expectancy of its promoters and called forth some of the highest commendations 85

HARVARD ITALIC

14 POINT

16 A 26 a 83 00

FIVE HUNDRED THOUSAND PEOPLE*Cheered Vociferously for Hours**The parade of veterans of the G. A. R. in the city of Buffalo, August 25, 1897, was a grand success. Massachusetts division numbered fully 3000 men*

12 POINT

18 A 30 a 83 00

BROOKLYN FEMALE ACADEMY BURNED*Destroyed by Fire New Years Day, 1853**Still in the ashes lived the wonted flame, and a new school rose, a stately monument to mark the spot. November 9, 1854, the Packer Collegiate Institute was officially opened*

10 POINT

20 A 34 a 82 75

FASHIONABLE MILLINERY AND DRESS GOODS*Latest Styles from London, Paris and Berlin**Our several departments are fully stocked with fresh merchandise which is matchless in quality, newness, variety and cheapness. It is now high tide of the Holiday Season, and buyers should not 46*

9 POINT

20 A 34 a 82 50

STAGES BETWEEN XYLOGRAPHY AND TYPOGRAPHY*No Question has Aroused Keener Discussion**No question has aroused more interest, or excited keener discussion in the history of printing, than that of the use of movable wooden types as a first stage in the passage from Xylography to Typography. 123456*

8 POINT

24 A 36 a 82 50

HARVARD ITALIC SERIES*Favorably Impress Artists**The beauty of a letter does not necessarily consist in the fancy ornament, but well-proportioned simplicity 86*

6 POINT

32 A 42 a 82 25

DISBAND OUR ORGANIZATION*By Order of Social Members**To secure time for more profitable employment we dissolve the society which in the past has monopolized our thoughts by day and our dreams while we quietly slumbered 123456*

TOURNAINE OLD STYLE ITALIC

42 POINT

4 A 6 a 87 25

MUSTER!
Roxbury will
send its horse
guards to see
the Framing-
ham pleasure
grounds for a
brief vacation
this season as
customary 12

TOURAINÉ OLD STYLE ITALIC

36 POINT

4 A 8 a \$5 50

AMERICA!
For piano and
cornet, the best
tune on the list
Only 24 Cents

30 POINT

5 A 10 a \$5 50

MARK DOWN
In prices of mining
sites and machines
for imitating eagles
and other birds. A
choice lot at \$3.65

STYLUS No 2

PATENTED

24 POINT

8 A 14 a \$5 00

Grand Autumnal Display
The Australian Tailoring Company
will Exhibit several Leading Styles
Wednesday, September 25th, 1894

18 POINT

8 A 20 a \$4 50

Our Ambition is to Give Satisfaction
For the convenience of buyers who live out of
town we have issued a Descriptive Catalogue,
magnificently embellished with Photogravures,
which we send to any address upon application

12 POINT

12 A 32 a \$4 00

Dress Goods, Millinery, Laces and Curtains

Our several departments are fully stocked with merchandise,
which is matchless in quality, style, variety and cheapness.
Prospective purchasers should find their way to our reliable
establishment, and examine our stock and prices. We have
an excellent corps of salesladies who are always glad some,
and who deem it a pleasure to display our goods to customers

STYLUS SERIES

PATENTED

24 POINT

6 A 14 a \$5 00

Swagger and Gasconade
 Inform the public that to-day they
 start in business confident of success

18 POINT

8 A 20 a \$5 05

Having Cut our Wisdom Teeth
 We are satisfied that we have ability of very
 high order, and ask you and your friends to
 examine our goods, prices and correct methods

12 POINT

12 A 32 a \$3 00

The Earthquake shook us Nearly out of our Boots
 And our goods off the top shelves. The stock is uninjured; but
 rather than rearrange it we will allow it to go at ninety-nine per
 cent. discount. Come early and often, and take advantage of the
 opportunity that offers itself to get one dollar's worth for a penny

1 2 3 4 5 6 7 8 9 0

9 POINT

12 A 32 a \$2 70

The Almshouse Doors are Wide Open for our Reception
 We close our business career this morning with the well-wishes of the sheriff, an
 immense stock of experience, some tattered clothes, no money, and many creditors;
 but our Wisdom Teeth are still in good condition, and in the future we shall exercise
 them on such alimentary substances as may be doled out to us by the authorities

1 2 3 4 5 6 7 8 9 0

PEN TEXT SERIES

36 POINT

3 A 3 A 10 a \$9 00

Lima School Board

30 POINT

3 A 3 A 20 a \$8 40

Insurance Agencies
Walton National Bank

20 POINT

3 A 3 A 20 a \$5 20

Transportation Companies
Great Atlantic and Pacific Railway

18 POINT

4 A 4 A 25 a \$5 00

Specimen of Modern Invention
Invitations, Visiting Cards and Programs

14 POINT

4 A 4 A 25 a \$4 70

Vine Merchant
Imported Fine Brandy
Choice Cigars

12 POINT

6 A 6 A 36 a \$4 35

Manhattan Socials
First Grand Entertainment
Admission Free

10 POINT

8 A 8 A 50 a \$4 50

Moorfield, Marx & Jacobs
Shoes, Boots, Slippers and Sippers

1234567890

8 POINT

20 A 60 a \$3 60

Second Grand Spring Opening
Fine Display of Easter Goods for Women

1234567890

TRISTAN ITALIC

30 POINT

4 A 4 A 25 a 88 00 4 A 25 a 86 15

Linkerton Detectives
Carrying Out Very Peculiar Instructions

24 POINT

5 A 5 A 30 a 87 50 5 A 30 a 85 40

The United States of America
The Monroe Doctrine will be Strictly Enforced

18 POINT

6 A 6 A 40 a 86 75 6 A 40 a 85 25

Mr. & Mrs. William Browning
Request Your Company at Their Daughter's Wedding
January 17th, 1897

12 POINT

10 A 50 a 84 35

What grand companionships await us as we turn from the noises and turmoil of life and sit down for an evening amongst our books. Kings of thought of every age stand in serried ranks before us waiting to do our bidding. Poets of the elder time, and of these

10 POINT

10 A 50 a 83 80

Reverie is the nurse of melancholy; and it often takes the place of work in what seems to be working hours, broods over the work, unravels the thread of thought, spreads a haze over the inward vision, and loosens the grasp of the apprehensive powers. This, then,

8 POINT

12 A 60 a 83 80

As flowers carry dewdrops trembling on the edge of the petals, and ready to fall at the first waft of wind or brush of bird, so the heart should carry its beaded words of thanksgiving, and, at the first breath of heavenly flavor, let down the shewer perfumed with the heart's gratitude. When the heart is thus in harmony with the will of

CHICAGO SCRIPT

36 POINT

12

Card Font 3 A 8 a \$6 00
Circular Font 5 A 25 a \$15 30

United States Depository

24 POINT

Card Font 4 A 12 a \$4 70
Circular Font 8 A 36 a \$11 75

The Directors Take Great Pleasure in

18 POINT

Card Font 6 A 16 a \$4 30
Circular Font 12 A 48 a \$10 75

Leather Dealers Protective Association Meeting
will be held on Saturday Evening November

SPINNER SCRIPT

32 POINT

12

Card Font 3 A 8 a \$4 80
Circular Font 5 A 25 a \$11 75

Convent Garden Promenades

24 POINT

Card Font 4 A 12 a \$4 75
Circular Font 8 A 50 a \$12 50

Ninety Days after Date we Promise to

24 POINT No 2

Card Font 4 A 12 a \$4 75
Circular Font 8 A 60 a \$12 50

Horticultural Society Reorganization
Silver and Copper Mining Companies

18 POINT

Card Font 6 A 16 a \$4 35
Circular Font 12 A 60 a \$10 00

The Meeting of Societies
will be held Each Month

12 POINT

Card Font 6 A 25 a \$3 25
Circular Font 15 A 75 a \$8 00

In the Prosecution of our Labors
we discover many Persons lying
under trees expecting some Fruit

PROGRAM SERIES

24 POINT

4 A \$1 20 6 A 12 a \$3 65

GRAND SOCIAL Debating

18 POINT 6 A \$1 05 8 A 16 a \$3 40

BROKE RING
FEAR Disaster

16 POINT 8 A \$1 00 12 A 24 a \$3 60

ENTERPRISED
SENDING Message

12 POINT 12 A \$0 95 18 A 36 a \$3 40

SPRING * FLOWERS
GERANIUMS Admired

10 POINT 18 A \$1 00 24 A 48 a \$3 40

HANDSOME PREMIUMS
Wild Flower COLLECTION

6 POINT 32 A 64 a \$2 90

OUR EXPERIENCE SHOWS THAT THE
apprentice foreshadows the tradesman
as well as the bend of the twig foretells
the inclination of the tree. The upright

8 POINT 18 A \$0 85 24 A 48 a \$2 80

COMMON WEALTH SOCIETY
PROGRESS of Civilization Since
Relieve Crowded Penitentiaries

INCLINED PROGRAM

24 POINT

6 A 12 a \$4 00

PATRIOTIC * Republican

18 POINT 8 A 16 a \$3 60

BOUNTIFUL
Large Booths

16 POINT 10 A 20 a \$3 50

ENTHUSIASM
Forces * Return

12 POINT 18 A 36 a \$3 60

PUBLIC SPEAKING
in the Court House of

10 POINT 18 A 36 a \$2 80

GIRLS OF EDUCATION
as a subject of greatest

6 POINT 32 A 64 a \$3 35

FIRST INVENTION OF PRINTING
has always been recognized among
Important Supreme Court Decision
Eighteenth Ward Female Suffrage

8 POINT 24 A 48 a \$3 10

IMPORTANT CONVENTION
Bankers Annual Meeting 98
Good Partnership Certificates

GROTESQUE No 120

30 POINT

6 A 12 a \$4 40

GRACEFUL Swimmers

24 POINT

20 a \$2 20 10 A 20 a \$4 15

PATENT PRINTING MACHINE
Charming and Glorious Scenery

18 POINT

20 a \$1 50 10 A 20 a \$2 90

TRANSPARENT
Obsolete Charge

12 POINT

24 a \$1 10 12 A 24 a \$2 10

AUTUMN EVENINGS
Making Artistic Carpets
Sunlight and Happiness

10 POINT

36 a \$1 25 18 A 36 a \$2 45

HONORABLE METHODS
Encouragement to Business
Cleaning Department 12345

8 POINT

36 a \$0 95 18 A 36 a \$1 90

ALL BLACKSTONE DECISIONS
Investigating Committee on Finance
Excitement Upsetting Sick Persons
State Prison National School 12345

FANCY GROTESQUE

30 POINT

6 A 12 a \$4 65

AMERICAN Enterprise

24 POINT

20 a \$2 10 10 A 20 a \$3 95

ASSEMBLE IN CONFERENCE
Venezuela Mariners Experience

18 POINT

20 a \$1 50 10 A 20 a \$2 90

WAR PENSIONS
Admiral Farragut

12 POINT

24 a \$1 15 12 A 24 a \$2 20

MORNING EXERCISE
Excursion Tickets to the
Paris Exposition Found

CIRCULAR GOTHIC No 120

24 POINT

Card Font 10 A 20 a \$3 20
Circular Font 10 A 40 a \$4 00

EXCELLENT HOUSE ENTERTAINMENTS
Artistically Staged Dramatic Productions
King Richard and Sir Joseph Surface 48

18 POINT

Card Font 12 A 24 a \$2 65
Circular Font 12 A 48 a \$4 05

CLASSIFIED AND UNABRIDGED CATALOGUE
For Convenience of Buyers who live out of town
we have issued a Descriptive Catalogue which 52

12 POINT

Card Font 18 A 36 a \$2 45
Circular Font 18 A 108 a \$5 05

PERILS OF COLUMBUS ON HIS VOYAGE OF DISCOVERY TO
the Westward. Indications of approaching land became more
certain, and excited hopes in proportion. The birds began to
appear in flocks, making towards the Southwest. Colum-
bus, in imitation of Portuguese navigators who had 713

10 POINT

Card Font 24 A 48 a \$2 45
Circular Font 24 A 144 a \$5 15

WORKS OF FAMOUS AUTHORS
sunk in oblivion. Paradoxical as
it may seem, the chief causes of
the oblivion of books is no longer
their extinction, but the fond care
with which they are preserved 904

8 POINT

Card Font 24 A 48 a \$2 10
Circular Font 24 A 144 a \$4 40

SAILORS LOSE HEART AND DESIRE
Columbus to turn about and sail for Eu-
rope. Despair, impatience and unbounded
rage appeared in every countenance. All
sense of subordination was lost, and a
scene of confusion ensued. The officers
who had previously concurred with Co-
lumbus in opinion, and supported 8253

CUSHING SERIES

12 POINT

EXHIBITION OF
SCIENCE CLUB
BOOK PAPERS.

1898

PARLORS OPEN
ENTIRE MONTH
OF APRIL, AND
THE PUBLIC IS
INVITED DAILY.

Can you afford to miss an opportunity for the preservation of your eyesight if it is presented to you? Many years since men of study, bookkeepers, clerks, and the like were unable to obtain any relief from the strain upon their eyes caused by the constant use of paper made in an unscientific manner. After many years of experiment and study we have made a paper in which this is eliminated.

14 A 8 A 36 A \$5 00

10 POINT

NEW SHADES IN MY LADY'S
STATIONERY FOR COUNTRY
AND SEASHORE EFFUSIONS.

One of the most attractive of the new shades has been called Antique Bronze. It is a very fair imitation of some verdigris-covered bronze of ancient statues and coins. Among the new shades of gray are Pearl Gray and the Gray Musketeer, both of which are neutral in tone and in contrast with most every variety of color in writing inks. Mauve and a sap green called Empire seem to be in favor, although neither of these are as attractive as the names might indicate. In our store will be found writing material of every description

FRANKLIN STATIONERY COMPANY
WASHINGTON INSURANCE ARCADE
SOUTH NORWALK, WEST VIRGINIA

16 A 10 A 40 A \$4 50

8 POINT

HIGHER IN QUALITY AND LOWER
IN PRICE SIX DAYS IN THE WEEK.

Many business houses seem to think a good reputation is something that their customers should pay a good price for. As soon as an enviable distinction is acquired, the price of goods is advanced and the cream is skimmed as long as it rises. Our goods are recognized as the standard of the world, and yet they were never sold so cheap as the present time.

SOUTH AMOSKEAG MANUFACTURING COMPANY
BROWN AVENUE, HYDE PARK, NORTH DAKOTA

20 A 12 A 44 A \$4 00

6 POINT

AUTOMATIC FLYING MACHINE COMPANY
ORGANIZED APRIL 1, 1900

These machines embody the results of thirteen unlucky days of foolishness and inexperience. In their construction the highest grade of gold bricks is used for the foundation, and inflation is of that quality of verdure which has gained for our house a reputation second to none in the country, otherwise known as the hay-seed district. Drop in and

SEE THEM SOAR, THEN DROP OUT AND
FEEL THE SORENESS

20 A 12 A 50 A \$3 50

CUSHING ITALIC

12 POINT

20 A 50 a \$3 94

*EMBRACING OPPORTUNITIES, TAKING
ADVANTAGE OF THE SITUATION, OR**Timing your action to the exact moment when all indications are
propitious, is the acme of good business judgment.**How many possess these qualities?*

1 2 3 4 5 6 7 8 9 0

10 POINT

28 A 80 a \$3 80

*MEN, LIKE PICTURES, MAY BE PLACED IN
AN OBSCURE OR UNFAVORABLE LIGHT!**There is a secret propensity in human nature, from generation to generation, in
the blockheads of one age to admire those of another.**Is lying a "clever" faculty?*

8 POINT

28 A 80 a \$3 00

THE OLD CANTEEN

*I tell you, Jim, it ain't no use,
A soldier can't forget,
Those bloody scenes are just as fresh
As on the day we met;
But all the relics of the war,
The broken sword, I ween,
E'en knapsack old, there is none like
The dear old tin canteen.**You recollect as well as I
The hunger and the thirst,
The mad career of horse and men,
Where rebel shells had burst;
But after all, you gray old vet.,
The best remembered scene
Was when we stole a chance to drink
From out the old canteen.*

6 POINT

28 A 80 a \$2 80

THE OLD BRASS KNOCKER

*Now, children dear, 't is the song of the knocker,
The old brass knocker of grandfather's days,
A sweet sad tale where harshly asunder
The household were torn in the prime of their Mays;
But turn to the picture now mellowed forever
By the gray hand of Time in his strange lapse of years,
And a home like your own so dear to your bosom,
May shine like a halo thro' the mist of your tears.*

LITHO SERIES

18 POINT

Card Font 8A 16a \$3 16
Circular Font 32A 112a \$16 75

Whereas, on the 18th day of May, 1897, Thomas,
Fiddlefaddle wâs found near the Public Hall, sitting
astride a fence, and therê remained whittling a pine

v° w° h° *These letters are mortised, not kerned* m° n° r°

WAVERLY CIRCULAR

12 POINT

Card Font 10A 20a \$3 00
Circular Font 30A 140a \$14 25

PECULIARITIES INHERITED

Man is a nomad. In his natural state, before he
was hampered by the conventionalities of society,
or the demands of trade and commerce, he had
wandered aimlessly from hither to yon. Where he
pitched his tepee or skin-covered hovel, there was

10 POINT

Card Font 12A 24a \$3 10
Circular Font 36A 150a \$13 85

ANCIENTS ORGANIZE EXPEDITIONS

The spirit of penetrating into unknown countries and
sailing trackless seas led the Egyptians nearly three
thousand years before Christ to build quaint vessels,
the prows of which they decorated with handsomely
carved images of goddesses, whose smiles they often
sought upon their explorations. It led the Norsemen

8 POINT

Card Font 14A 30a \$3 00
Circular Font 40A 180a \$10 85

ENTHUSIASTIC POPULATION DESCRIBED

There is, perhaps, no nation in which the inborn instinct to travel
is stronger than in the American. Go where you will, you find the
country is webbed with railroads, and the stations and trains filled
with an ever-restless throng. Stand upon the wharves and see the
ocean steamers leave, their decks crowded with tourists, and the

1234567890

APOLLO SERIES

18 POINT

9 A 18 a \$4 00

ARTISANS TALENTS UNKNOWN
 Every day sends to their graves a number of obscure men, who have only remained such on account of their extreme timidity, which they have not been able to conquer \$65

12 POINT

12 A 28 a \$3 50

THE VAGABOND AND CONTEMPTIBLE ROGUE
 Beware of those who are homeless by choice. You have no hold on a human being whose affections are without a tap-root. The laws recognize this truth in the privileges which they confer upon the freeholder and the responsible citizen; and public opinion acknowledges it as a just decision, though seemingly harsh in its sweeping denunciation of individuals who are not self-supporting \$342.60

10 POINT

14 A 32 a \$3 25

JOYFUL SPRING MONTHS
 I love to look on these young faces, and see the firstlings of a young man's beard, and the maidenly bloom blushing over the girl's fair cheek; I love to see the eyes beaming with joy and goodness, to see the unconscious joy of such young souls impatient of restraint, and longing for \$491

8 POINT

20 A 44 a \$3 00

TIME IS THE CRADLE OF DESTINY
 Time constantly flies, yet it overcomes all things by flight; and although it is the present ally, it will be the future conqueror of Death. Time, the cradle of Hope, but the grave of Ambition, is the stern corrector of Fools, but it is the salutary counselor of the Wise, bringing all they dread to the one, and all they desire to the other; but, like Cassandra, it warns us with a voice that even the sagest discredit too long, and the silliest believe too late \$23,416.78

ALFERETA SERIES

36 POINT

4 A 8 a \$6 00

National Candidate Popular Heroes

30 POINT

5 A 10 a \$5 25

Musical Festival Opened Orchestral Exercises

24 POINT

6 A 12 a \$4 50

Photographic Views Reproduced Improved Lenses 43 Amateurs Purchasing Material

18 POINT

8 A 16 a \$3 50

Kavana Mercantile Insurance Company Capital Stock \$2580 Conscientious Representatives Employed

12 POINT

8 A 30 a \$2 75

Philosophical Association Distributing Patriotic Literature History of the United States 1786 Declaration of Independence and other Interesting Papers

ISABELLA SERIES

PATENTED

18 POINT

6 A 20 a 64 15

Invitation to Fashionable Damsels Display of Paris Styles

Every requirement in quality and cheapness combined in our superior stock of Millinery Goods, Ostrich Plumes and Silk Ribbons

12 POINT

8 A 32 a 63 80

Headquarters Ladies' Dress Reform Club

Special Circular, No. 23,857

In pursuance of Resolution adopted at the November meeting, members will hereafter, when visiting places of amusement, refrain from wearing towering bonnets and hats decorated with soaring plumage and flowers, as it will be a great benefit to the people in the rear

9 POINT

10 A 35 a 63 45

Enforced Sale of Fashionable Hats and Trimmings

Entire Stock will be Sacrificed

Owing to resolutions recently passed by the Ladies' Dress Reform Club, the undersigned will dispose of their entire stock of Unique and Stylish Headgear, consisting of Ostrich Plumes and Bonnets. As no reasonable offer will be refused, ladies are invited to call on us and examine this pretty and stylish assortment of goods before the opening of the opera season, which will occur next week

September 4, 1896

Collins & Jackson

CHELSEA CIRCULAR

18 POINT

9 A 30 a \$5 00

A CELEBRATED HISTORICAL WORK MERITORIOUS RESEARCH

The vastness of the universe must render foolish the supposition that this planet is the only inhabited \$85

12 POINT

12 A 40 a \$3 00

LOCAL ABIDING OF A WORTHY AND TRUE CITIZEN EVENTS SKETCHED FROM MEMORY

To my son Tom, I bequeath all right and title to the Good Name which I intend to leave behind me, and any profit or renown which may be derived therefrom shall be for his sole benefit. To my daughter Mary, I give all shares in the Comet-Tail Utilization

10 POINT

18 A 60 a \$3 50

MUSCULAR GENTLEMEN EXHIBIT GREATEST ENDURANCE REMARKABLE CHARACTERISTIC METHOD

Health is the soul that animates all enjoyments of life, which fade, and are tasteless, if not dead, without it. Man starves at the best and the greatest tables, makes faces at the most delicate wines, is old and impotent in seraglios of the most sparkling beauties, is poor and wretched in the midst of the greatest treasures; with diseases, strength

8 POINT

24 A 80 a \$4 50

ALL SCORING THE PRINTERS CRAFT PUBLICATION

Does the printer read up in his profession as thoroughly as he should? I should say not. It is a deplorable fact, but nevertheless true, that, as a class, the printers of this country do not keep read up on the \$23456

6 POINT

24 A 80 a \$4 00

HABITS OF THE SLOUCHY PRINTER GREAT ANNOYING EVILS

Numberless interesting experiments are performed by compositors in the several processes of setting and distributing type, that may be justly classified outside the pale of typographic tolerance. As long as the offender is unnoticed or not discovered in his mean habits, 17890

SIGNET SERIES

9 POINT

12 A 24 a 32 10

I love to look on these young
faces, and see the firstlings of
the young Man's beard, and the
maidenly bloom blushing over the
Girl's fair cheek; I love to see the
pure eyes beaming with joy and
goodness, to see the unconscious
joy of such young souls impatient
of restraints, and longing for the
Heaven that we fashion here.
So have I seen in early May 123

18 POINT

8 A 16 a 33 85

Every day sends to their
graves a number of the
obscure Men, who have
only remained as such
because of that Timidity
whose hold on a human

36 POINT

4 A 8 a 36 60

Roberts & Lockers
Spring 89 Opening
Dry Goods and Furnishings

24 POINT

6 A 12 a 34 40

Let honesty be the
breath of each Soul,
and never forget to
have a Dime or two
When all shall go 3

12 POINT

10 A 20 a 32 70

Our several Departments
are fully stocked with fine
Merchandising, matchless
in Quality, Style, Variety
and Cheapness. We have
intelligent corps of Sales-
ladies who always deem
it a Pleasure to display
our Goods to every 456

RAMONA SERIES

30 POINT

8 A 14 a \$4 75

The Charming Production of Robinson Crusoe received with Uproarious Enthusiasm £236.50

24 POINT

8 A 20 a \$4 60

Quick-selling Ghesterfield Spring Overcoats that are decidedly English and very Fashionable for \$58.76

18 POINT

10 A 32 a \$4 60

Next Thursday is Opening Day in our Millinery Department Surprises in Winter Headgear from Parisian Fashions await your Critical Inspection. Trimmings of unusual fineness \$24.15

PENCILINGS

20 POINT No 2

24 a \$2 45

8 A 24 a \$4 70

The pages of early Books were either large or small Folios, but sometimes Quartos, and 85

20 POINT

24 a \$3 30

8 A 24 a \$5 55

Laxton was over sixty years of age when The Dictes was printed, and was noted for his Industrious Habits 62

10 POINT

30 a \$1 90

8 A 30 a \$2 90

Recent improvements in Delusive Appliances have brought them so near perfection that fugitive Cashiers and fraudulent Debtors may be caught on the wing, Voters entrapped for Office-Seekers, lost Dogs speedily recovered, Subscribers obtained for uninteresting papers 1349

GUTENBERG SERIES

24 POINT

5 A 10a \$3 60

Commendable · Principles · and · Practices
 Promptness in Settling Accounts 368

18 POINT

6 A 14a \$3 20

Distracted · Proprietors · and · Exasperated · Patrons
 Initiating an Awkward Squad of Youths into the
 Art and Mysteries of the Printing Business 1429

12 POINT

8 A 20a \$2 45

The · Commonwealth · Finance · Company · of · Squanderquick · Kentucky
 Provides Methods to Speedily Reduce the Weight of Pocket-Books,
 Makes Openings for Dropping Hard Earnings into Saloon Mills 57

GRIMALDI SERIES

24 POINT

7 A 14a \$4 50

☉ MANDSOME EMBROIDERIES ☉
 Lace curtains are coming out of closet
 and chest for the fall season fixing 1387

18 POINT

8 A 16a \$3 50

⊕ ANTIQUE FURNITURE REMODELLED ⊕
 Reupholstering is an important and large part of our
 business and this is a good time to send for us. 7892

Ornaments with each size

LAW ITALIC

28 POINT No 42

7 A 14 a \$4 50

REGULATION FOR VOTERS
Citizens must have Paid Taxes

22 POINT No 42

8 A 20 a \$3 60

HIGH COURT OF FINAL APPEALS
*Right of Appeal from the Lower Court
 is hereby Extended to any Defendant*

18 POINT No 122

10 A 28 a \$3 00

WELCOMED RESTRICTIVE PROCEEDINGS
*Notice is hereby given that Imperative Orders
 were Issued to rigidly Enforce the Curfew Law*

12 POINT No 122

14 A 42 a \$3 00

HONORARY CERTIFICATE
*This is to certify that Robert
 Jay Nevertail is an Honorary
 Member of the Noble Society
 to facilitate Corner Lounging*

10 POINT No 122

20 A 52 a \$2 80

SUMMONS AGAINST A MASTER
*You are hereby commanded to take
 the body of Ephraim Lazy, if he can
 be found in this County, and bring
 him before me, Jonathan Resolute, a
 Justice of the Peace, to be sentenced*

8 POINT No 122

25 A 70 a \$2 85

AN INDENTURE OF APPRENTICESHIP
*This Indenture witnesseth: That Marion
 Highstrung with and by the consent of her
 mother, as her next friend, has bound and
 put herself apprentice to Arabella Lofty, to
 learn the art of Extravagant Housekeeping*
 1 2 3 4 5 6 7 8 9 0

6 POINT No 122

25 A 70 a \$2 45

COMMONWEALTH VERSUS JOSEPH SLOWPAY
*Whereas Joseph Slowpay, of Indolent Township, in
 this County, hath failed to pay his Dog Taxes for
 one year, according to law, therefore we command
 that you summon the above said Joseph Slowpay to
 appear before us and show ample and satisfactory
 cause why he hath failed to make such payments*
 1 2 3 4 5 6 7 8 9 0

LAW ITALIC No 120

12 POINT

Card Font 9 A 25 a 82 10
Circular Font 18 A 100 a 86 80

Said Company furthermore agrees to make good to the assured Persons all Damages from Water which is the Result of a Fire in the Adjoining Building, provided that Precaution was Taken

10 POINT

Card Font 12 A 35 a 82 30
Circular Font 24 A 140 a 87 40

Pursuant to Section 2935 of the Code of this State, we hereby furnish you with the List of Persons subject to Taxation and Valuation required by Law to be yearly ascertained, together with the Amounts paid by them

8 POINT

Card Font 16 A 50 a 82 50
Circular Font 32 A 200 a 88 05

In case of Violation of any of the foregoing Conditions upon which the Policy is issued and accepted, as mentioned before, this Policy shall become Void
1 2 3 4 5 6 7 8 9 0

6 POINT

Card Font 16 A 50 a 82 00
Circular Font 32 A 200 a 86 70

This Agreement is made and accepted subject to the Foregoing Conditions and Stipulations, together with such Provisions as may be added thereto, and no Officer of the Company shall have Power to Cancel the Regulation
1 2 3 4 5 6 7 8 9 0

COPPER ALLOY FINE-DOT LEADERS

These are used as a substitute for Dotted Brass Rule, and save the time spent in justification. Made on 6, 7, 8, 9, 10, 11 and 12 Point bodies. When ordering, state the type (if our make) they are required to line with, or send cap "H" or lower-case "m." The following examples show Fine-Dot Leaders lining with 8 Point and 10 Point Law Italic No. 120 and 8 Point and 10 Point Law Italic No. 122:

8 POINT LAW ITALIC NO 120

In combination with 8 Point Fine-Dot Leaders

*A Court of..... will
be held on the..... day of
..... in the city of.....*

8 POINT LAW ITALIC NO 122

In combination with 8 Point Fine-Dot Leaders

*In consideration of \$..... and
..... cents, we hereby agree to lease
the building on premises.....*

10 POINT LAW ITALIC NO 120

In combination with 10 Point Fine-Dot Leaders

*You..... are
commanded by.....
..... to take before*

10 POINT LAW ITALIC NO 122

In combination with 10 Point Fine-Dot Leaders

*Executed this..... day of.....
189..... in..... County of
..... in presence of the*

Put up in 5-lb. fonts at the following prices per lb.:

6 Point Per pound \$0 64	9 Point Per pound \$0 48	11 Point Per pound \$0 44
7 Point Per pound 56	10 Point Per pound 46	12 Point Per pound 42
8 Point Per pound 52		

CIRCULAR ITALIC No 120

24 POINT

10 A 50 a 86 10

The Invention of Printing has always been recognized by Educated Men as a subject of great importance: there is no mechanical art, nor are there any of 85

18 POINT

10 A 50 a 84 65

The Invention of Printing has invariably been recognized by educated men as a subject of vast importance: there is no mechanical art, nor are there any of the fine arts, about whose early history so many books have been written and 42

12 POINT

18 A 100 a 85 40

The Invention of Printing has always been recognized by educated men as a subject of importance: there is no mechanical art, nor are there any of the fine arts, about whose early history so many books have been written. The subject is as mysterious as it is inviting. There is an unusual degree of obscurity about the origin of 379

10 POINT

24 A 140 a 85 95

The Invention of Printing has always been recognized by the educated man as a subject of great importance: there is no mechanical art, nor are there any of the fine arts, about whose early history so many books have been written. There 369

8 POINT

32 A 200 a 86 35

The Invention of Printing has always been recognized by educated men as a subject of vast importance: there is no mechanical art, nor are there any of the fine arts, about whose early history so many books have been written. The subject is as mysterious as it is inviting. There is an unusual degree of obscurity about the origin of the first printed books and the lives and works of the 7348

VENETIAN SERIES

18 POINT NO 122

Card Font 10 A 50 a 86 15
Circular Font 20 A 100 a 812 30

The Invention of Printing has always been recognized by educated men as a subject of importance: there is no mechanical art, nor are there any of the fine arts, about whose early history so many books have been written, the 45

18 POINT NO 121

Card Font 10 A 50 a 86 00
Circular Font 20 A 100 a 812 00

The Invention of Printing has always been recognized by educated men as a subject of importance: there is no mechanical art, nor are there any of the fine arts, about whose early history so many books have been written, the 27

12 POINT NO 122

Card Font 10 A 50 a 83 25
Circular Font 20 A 100 a 86 50

The Invention of Printing has always been recognized by educated men as a subject of importance: there is no mechanical art, nor are there any of the fine arts, about whose early history so many books have been written. There is an unusual degree of obscurity about the origin of the first printed books and the lives and works of early 67

12 POINT NO 121

Card Font 10 A 50 a 83 05
Circular Font 20 A 100 a 86 10

The Invention of Printing has always been recognized by educated men as a subject of importance: there is no mechanical art, nor are 89

10 POINT NO 120

Card Font 12 A 70 a 84 05
Circular Font 24 A 140 a 88 10

The Invention of Printing has always been recognized by the educated men as a subject of great importance: there is no mechanical art, nor are there any of the fine arts, about whose history 34

REMINGTON STANDARD

12 POINT

110a \$5 25 20A 110a \$7 25

The Island of Hawaii is the largest one of the Hawaiian group and is about 300 miles in circumference, is in the form of two great twin peaks--Mauna Loa and Mauna Kea--rising out of the sea to a height of nearly 14,000

CALIGRAPH

12 POINT No 4

15A 70a \$6 20

Now Sir Launcelot and Sir Gawaine were wroth by cause Sir Kay in jest had mocked Beumain's, and a damosel which desired a knight to fight for a lady. Thereat was Sir Gawaine wroth, and in especial Sir

YOST TYPEWRITER

12 POINT

90a \$4 65 20A 90a \$6 50

We beg to call your attention to this exact imitation of Yost Typewriter Type which was made especially for "imitation" work. No expense has been spared to make this type the most perfect imitation ever placed on

TYPEWRITER

12 POINT

108a \$4 10 20A 108a \$7 50

Never in the history of type founding has any face of jobbing type attained a sale and popularity equaling that of this imitation of type-writing machines. The demand for it is co-extensive with the march of civiliza-

Spaces are included with each font of Typewriter

SMITH-PREMIER TYPEWRITER

12 POINT

108 a \$4 10 20 A 108 a \$7 50

The vastness of the universe must render foolish the supposition that this planet is the only inhabited one; and the unity of laws and of substances asks us to imagine the beings upon other spheres to be moving

TYPEWRITER SERIES

14 POINT No 2

75 a \$5 30 15 A 75 a \$7 50

In this new Type-Writer every character is cast on en set, and for spaces the common en quad is used. Job men in general favor this idea, and its popularity is increasing. Its adaptability for printing circulars is plain

10 POINT No 2

85 a \$3 50 18 A 85 a \$5 00

Having had a number of calls for a 10-Point "Type-Writer" we take great pleasure in showing this specimen in answer to the demand, trusting it will meet with a cordial reception among the members of the craft. All the characters in this font are cast on en set, and for spaces or justifiers en quads may be used, if the supply sent with the font is not sufficient. We

12 POINT EARLE

108 a \$4 10 20 A 108 a \$7 50

Since the original imitation of Type-Writer work was first produced there have been many changes made in the machines, and this Earle style is a copy of most improved. Very convenient in a considerable amount of matter

Spaces are included with each font of Typewriter

PALO ALTO

24 POINT

6 A 20 a \$5 50

POPULAR & SENTIMENT

The profit of Advertising chiefly comes in inducing people to buy more than they need. Civilization is indicated by the extent to which a people indulge in various luxuries & \$3.68

18 POINT

8 A 26 a \$5 00

GENERAL DEPARTMENT STORE

We wish to call your attention to our fine stock of China and Glassware, Bohemian Vases and Dresden Wares of every description which we are prepared to offer at the unusually low price of \$123456890

SANTA CRUZ

24 POINT

18 A \$3 75

BENEVOLENT ASSOCIATIONS ORGANIZED
CONSTITUTION & RECONSIDERED

18 POINT

24 A \$3 00

ARTISTIC & DECORATION
EARTHENWARE \$3

12 POINT

30 A \$2 50

GALISTHENIC & AMUSEMENTS
ADVANCEMENT \$387

MULTIFORM No 1

36 POINT 4 A \$4 25

DRAIN

30 POINT 5 A \$3 75

BINDER

24 POINT 6 A \$3 25

WINTERS

18 POINT 8 A \$2 75

BOND * SOLD
123456

MULTIFORM No 3

36 POINT 4 A \$4 25

DRAIN

30 POINT 5 A \$3 75

BINDER

24 POINT 6 A \$3 25

WINTERS

18 POINT 8 A \$2 75

BOND * SOLD
123456

MULTIFORM No 2

36 POINT 4 A \$4 25

DRAIN

30 POINT 5 A \$3 75

BINDER

24 POINT 6 A \$3 25

WINTERS

18 POINT 8 A \$2 75

BOND * SOLD
123456

MULTIFORM No 4

36 POINT 4 A \$4 25

DRAIN

30 POINT 5 A \$3 75

BINDER

24 POINT 6 A \$3 25

WINTERS

18 POINT 8 A \$2 75

BOND * SOLD
123456

The Multiform Series make a fine effect when one is printed over the other in different tints. See page 434

STIPPLE SERIES

PATENTED

48 POINT

6 A \$6 90



36 POINT

7 A \$5 35



FILLET SERIES

PATENTED

36 POINT

4 A \$4 85



24 POINT

7 A \$3 85



18 POINT

9 A \$3 25



Space and End Ornaments furnished with fonts

ARBORET SERIES

36 POINT

4 A \$5 75

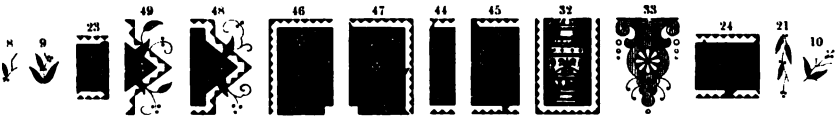

24 POINT

8 A \$5 00



MEZZOTINT SERIES

36 POINT

6 A \$6 25



24 POINT

6 A \$4 50



Three styles of End Ornaments furnished with each size

LURAY SERIES

PATENTED

36 POINT

3 A \$5 40

PUNCHERS

30 POINT

4 A \$4 30

SIXTH GAME

24 POINT

5 A \$3 35

SPRING SUNSET

18 POINT

6 A \$2 70

**HOMES FOR MINERS
DEMANDS 56**

SHADOW SERIES

PATENTED

36 POINT

3 A \$4 60

EXECUTORS

24 POINT

7 A \$4 00

TICKET PUNCHING

18 POINT

10 A \$3 40

**RENDERED
TIME 15**

12 POINT

16 A \$2 75

**SEASON TICKET
FUNDS 34**

STEELPLATE GOTHIC

PATENTED

36 POINT

4 A \$4 10

RENOUNGEMENT

24 POINT

7 A \$3 00

MORNING AMUSEMENT

18 POINT

8 A \$2 45

EMINENT AMERICAN DOCTOR

12 POINT

12 A \$2 15

PERFECTLY RELIABLE INFORMATION
VOUCHSAFED 890

TINTED SERIES

PATENTED

36 POINT

4 A \$4 60

WATERWORKS

30 POINT

5 A \$3 85

MAIDEN

24 POINT

7 A \$3 30

RAMBLES

18 POINT

8 A \$2 65

ORCHESTRA
BAND 53

12 POINT

12 A \$2 15

ORGAN BUILDERS
UNION 532

RAPHAEL SERIES

36 POINT

4 A 6 a \$5 50

DEFENCE OUTLINED
 Sound Foreign Policies

24 POINT

6 A 8 a \$4 00

GRAND HISTORICAL EVENTS
 National Pride Creates Respect

18 POINT

10 A 15 a \$3 25

PRAISING HONEST PRINCIPLES ABROAD
 Humanitarian Doctrine Reflected Broadcast
 1 2 3 4 5 6 7 8 9 0

CRAYON SERIES

36 POINT

3 A 5 a \$6 30

Resolved & Decisive

24 POINT

5 A 10 a \$5 15

Generous Republic Thanked

18 POINT

5 A 12 a \$4 06

*Triumphant American Diplomats
 Concessions Granted &c*

LITHOTINT SERIES

36 POINT

4A 8a 86 75

MODEST Charmers

24 POINT

6A 12a 85 50

DEPARTING ARTILLERY
 Retire National Contractors

18 POINT

8A 16a 84 75

AUTHENTIC ANCIENT RECORDS
 Considered Indispensable Luxury 23

HALFTONE SERIES

36 POINT

4A 8a 86 30

MAIDEN Help Miners

24 POINT

6A 12a 84 50

NERVOUSLY GESTICULATED
 Greater Variety of Ornaments

18 POINT

8A 16a 83 95

SEVENTY PLEASANT SPECTATORS
 Foreign Commissions of Immigration 38

ARGENT SERIES

36 POINT

4A 8a 86 50

Honest and Reliable
Laudable Business Maxims

24 POINT

6A 12a 84 50

Metropolitan Newspapers
Exercise Discretion in Voicing Sentiments
1234567890

SIGNET SHADE

36 POINT

4A 8a 87 30

House Designs
Rustic Beauty Shows

24 POINT

6A 12a 85 00

Christmas Greetings
Secured Enterprising Merchant
Reasonable 58

STENCIL SERIES

36 POINT

4 A 6 a \$7 90

BRICK Houses

24 POINT

6 A 8 a \$5 20

Quaint CORNER Store

18 POINT

7 A 10 a \$4 20

**RAISING
Hardy Plants
1 2 3 4 5**

12 POINT

10 A 16 a \$3 30

**MOONLIGHT
Frolicsome Parties
1 2 3 4 5 6 7**

VENUS SERIES

30 POINT

7 A \$3 25

ELECTRIC REGISTER

20 POINT

10 A \$2 75

INSTRUCTION

14 POINT

16 A \$2 75

VIRGINIA RESORTS

REMBRANDT SERIES

36 POINT

5 A \$2 85

BEAUTIFUL RESIDENCE

24 POINT

7 A \$2 15

BRIER DESIGN

18 POINT

10 A \$2 00

MUSICAL LEADER

ROUMANIAN SERIES

48 POINT

3 A \$8 40

GRAND

36 POINT

4 A \$6 85

DANCING

24 POINT

6 A \$4 95

EIGHT MORE

18 POINT

8 A \$4 05

SQUARE

12 POINT

10 A \$2 60

FINE STOCK

9 POINT

12 A \$2 15

NOTABLE HERO
DEWEY 98

6 POINT

18 A \$2 00

LIGHTHOUSE SOLITUDE
PROMENADE 46

BROADGAUGE ORNATE

36 POINT

5 A \$7 80

DRINKER

28 POINT

5 A \$5 65

TIME

22 POINT

7 A \$4 60

SENSE

18 POINT

10 A \$4 80

SCORES
BIG 14

12 POINT

14 A \$3 80

INCLUDING
SHOP 66

POSTER OLD STYLE ANTIQUE No 120

30 POINT

25 LB FONT \$12 50

RIGHT PREVAILED
 When, in the course of
 human events, it should
 be necessary for one \$84

24 POINT

25 LB FONT \$12 50

DEVOTED TO THE FLAG
 When, in the course of human
 events, it becomes necessary to
 dissolve the political bands \$75

18 POINT

25 LB FONT \$13 00

GOVERNMENT FOUNDATION
 When, in the course of these events,
 it becomes necessary for one people
 to dissolve the political bands which
 have connected them with these \$123

12 POINT

25 LB FONT \$13 50

BOLD DECLARATION OF INDEPENDENCE
 When, in the course of human events, it becomes
 necessary for one people to dissolve the political
 bands which have connected them with another,
 and to assume, among the powers of the earth,
 the separate and equal station to which the \$236

Fonts do not contain spaces and quads

 POSTER DE VINNE

36 POINT

25 LB FONT \$12 50

SOUND THEORY
 When the leading
 spirits of a nation
 become aware 153

30 POINT

25 LB FONT \$12 50

RIGHTS OF LIBERTY
 When in the course of
 time it becomes neces-
 sary for one people 178

24 POINT

25 LB FONT \$12 50

ALEXANDER HAMILTON
 When in the course of time
 it became necessary for one
 people to dissolve the bands
 connecting them with 1264

Fonts do not contain spaces and quads

— " —

POSTER DE VINNE

18 POINT

25 LB FONT \$13 00

DECLARE OUR INDEPENDENCE
 When, in the course of time, it will be found necessary for one people to dissolve the bands which have connected them with another, and 234

12 POINT

25 LB FONT \$13 50

PROCLAIM LIBERTY THROUGHOUT THE LAND
 When, in the course of human events, it becomes necessary for one people to dissolve the bands which have connected them with another, and to assume, among the powers, the separate and equal station to which the laws of nature and of nature's God entitle them, a decent respect to the opinions of mankind 567

10 POINT

25 LB FONT \$16 25

THE BASIS FOR THE CONSTITUTION OF THE UNITED STATES
 When, in the course of human events, it becomes necessary for one people to dissolve the political bands which have connected them with another, and to assume, among the powers of the earth, the separate and equal station to which the laws of nature and of nature's God entitle them, a decent respect to the opinions of mankind requires that they should declare the causes which impel them to the separation. We hold these truths to be self-evident 890

8 POINT

25 LB FONT \$20 00

REVOLUTIONARY CONVENTIONS
 When, in the course of events, it becomes necessary for one people to dissolve the political bands which have connected them with another, and to assume, among the powers of the earth, the separate and equal station to which the laws of nature and of nature's God entitle them, a decent respect to the opinions 1358

6 POINT

25 LB FONT \$25 00

RIGHTS OF THE COLONIES RESERVED
 When, in the course of human events, it becomes necessary for one people to dissolve the political bands which have connected them with another, and to assume, among the powers of the earth, the separate and equal station to which the laws of nature and of nature's God entitle them, a decent respect to the opinions of mankind requires that they should declare the causes which impel them to the separation. We hold these truths to be self-evident, that all men are created equal; that they are endowed 2467

Fonts do not contain spaces and quads

 POSTER DE VINNE CONDENSED

30 POINT

25 LB FONT \$12 50

FREEDOM AND LIBERTY
When, in the course of time
it seems necessary for one
people of equal station 1475

24 POINT

25 LB FONT \$12 50

SUFFERINGS OF THE COLONIES
When, in the course of human life,
it becomes necessary for one people
to dissolve the political band which
connected them with another 1392

18 POINT

25 LB FONT \$13 00

OUR PROTEST AGAINST UNJUST TAXES
When, in the pursuit of human events, it
becomes necessary for one people to break
the political bands which have joined them
with one another, and to assume, among the
powers of the earth, the separate and 7986

Fonts do not contain spaces and quads

POSTER DE VINNE CONDENSED

14 POINT

25 LB FONT \$13 00

LONG FOLLOWING OF ABUSES AND USURPATION

When, in the course of human incidents, it becomes necessary for one people to break the political bands which have connected them with one another, and to assume, among the powers of the earth, the separate and equal station to which the laws of nature 1947

12 POINT

25 LB FONT \$13 50

ALTERING FUNDAMENTALLY THE FORMS OF GOVERNMENT

When, in the course of human events, it becomes necessary for one people to dissolve the political bands which have connected them with one another, and to assume, among the powers of the earth, the separate and equal station to which the laws of nature and of nature's God entitle them, a decent respect to the opinions of mankind requires that they should declare the causes 5973

10 POINT

25 LB FONT \$16 25

TAKING AWAY OUR CHARTERS, ABOLISHING OUR MOST VALUABLE LAWS

When, in the course of human events, it becomes necessary for one people to dissolve the political bands which have connected them with one another, and to assume, among the powers of the earth, the separate and equal station to which the laws of nature and of nature's God sanction them, a decent respect to the opinions of mankind requires that they should declare the causes which impel them to the separation. We hold these truths to be self-evident, that all men are created equal; that they are endowed by their Creator with certain unalienable rights; that among these are life, liberty, and the pursuit of happiness. That 7439

8 POINT

25 LB FONT \$20 00

ENLARGING ITS BOUNDARIES AND MAKING IT AN EXAMPLE AND OBJECT FOR RULE

When, in the course of human events, it becomes necessary for one people to dissolve the political bands which have connected them with another, and to assume, among the powers of the earth, the separate and equal station to which the laws of nature and of nature's God entitle them, a decent respect to the opinions of mankind requires that they should declare the causes which impel them to the separation. We hold these truths to be self-evident, that all men are created equal; that they are endowed by their Creator with certain unalienable rights; that among these are life, liberty, and the pursuit of happiness. That, to secure these rights, governments are instituted among men, deriving their just powers from the consent of the governed; that, whenever any form of government becomes destructive of these 7195

Fonts do not contain spaces and quads

POSTER ANTIQUE No 125

48 POINT

26 LB FONT \$12 50

REPUBLIC
When their
safety in \$8

36 POINT

26 LB FONT \$12 50

IDEAL HERO
Whenever it is
necessary for 6

30 POINT

26 LB FONT \$12 50

EMINENT RIGHT
When, in course of
human events, the
political bands that
connects them \$52

Fonts do not contain spaces and quads

12

POSTER ANTIQUE No 125

24 POINT

25 LB FONT \$12 50

TRUTHS ESTABLISHED
 When, in course of human events, it surely becomes necessary for a people \$57

18 POINT

25 LB FONT \$13 00

REVOLUTIONARY FATHERS
 When, in the course of human events, it becomes necessary for one people to dissolve the political bands which connected \$84

12 POINT

25 LB FONT \$13 50

NOBLE DECLARATION OF INDEPENDENCE
 When, in the course of human events, it becomes necessary for one people to dissolve the political bands which have connected them with another, and to assume, among the powers of the earth, the separate and equal station to which the laws of nature and nature's God entitle them, a \$409

10 POINT

25 LB FONT \$16 25

PEOPLE ABOLISHING DESTRUCTIVE GOVERNMENT
 When, in the course of human events, it becomes necessary for one people to dissolve the political bands which have connected them with another, and to assume, among the powers of the earth, the separate and equal station to which the laws of nature and of nature's God entitle them, a decent respect to the opinion of mankind requires that they should declare the causes which impel them to the separation. \$532

Fonts do not contain spaces and quads

POSTER IONIC

* 42 POINT NO 159

25 LB FONT \$12 50

THE PUBLIC
When in time it
may become 23

36 POINT

25 LB FONT \$12 50

HUMAN EVENT
When, in the course
of human events \$8

30 POINT

25 LB FONT \$12 50

POLITICAL RIGHTS
When, in the course of
human events, it may
become necessary \$56

Fonts do not contain spaces and quads

POSTER IONIC No 122

24 POINT

25 LB FONT \$12 50

FATHERS OF REPUBLIC
 When it is necessary, in the
 course of human events, for
 one people to dissolve the
 political bands which \$742

18 POINT

25 LB FONT \$13 00

GOVERNMENTS INSTITUTED
 When, in course of human events,
 it may become necessary for one
 people to dissolve political bands
 which have connected them with
 another, and assume, among \$389

12 POINT

25 LB FONT \$13 50

STRONGLY ESTABLISHED GOVERNMENT
 When, in the course of human events, it be-
 comes necessary for one people to dissolve
 the political bands which have connected
 them with another, and to assume, among
 the powers of the earth, the separate and
 equal station to which the laws of nature
 and of nature's God entitle them, a decent
 respect to the opinions of mankind requires
 that they should declare their causes \$561

Fonts do not contain spaces and quads

POSTER LATIN ANTIQUE No 120

36 POINT

25 LB FONT \$12 50

NOBLE NEWS
When it is found
necessary in the
course of human
events for a \$45

30 POINT

25 LB FONT \$12 50

UNITED REPUBLIC
When, in the course
of human events, it
becomes necessary
for a person to dis-
solve political band
which connects \$82

Fonts do not contain spaces and quads

 POSTER LATIN ANTIQUE No 120

24 POINT

25 LB FONT \$12 50

REPUBLIC ASPIRATION
 When in course of human events, it should become necessary for one people to dissolve political \$76

18 POINT

25 LB FONT \$13 00

SIGNING OF INDEPENDENCE
 When in course of human events it should become necessary for one people to dissolve political bands which connect them with another, and to assume among the powers of the earth, the \$39

12 POINT

25 LB FONT \$13 50

REPUBLIC ORGANIZING GOVERNMENTS
 When, in the course of human events, it becomes necessary for one people to dissolve the political bands which have connected them with another, and to assume, among the powers of the earth, the separate and equal station to which the laws of nature and of nature's God entitle them, a decent respect to the opinions of mankind \$1245

Fonts do not contain spaces and quads

POSTER DORIC No 120

36 POINT

26 LB FONT \$12 50

OUR FREEDOM
When it is found
in the course of
human events to
be necessary \$2

30 POINT

26 LB FONT \$12 50

HUMANE BONDS
When, in the path
of human events, it
becomes necessary
for a people to free
itself from the \$57

Fonts do not contain spaces and quads

 POSTER DORIC No 120

24 POINT

25 LB FONT \$12 50

REPUBLIC LEADERS
When it is necessary
in the course of human
events, for one people
to dissolve bonds \$123

18 POINT

25 LB FONT \$13 00

MODERN DECLARATION
When it becomes, in the
course of human events,
necessary for one nation
to dissolve the bands that
have connected them to
another, and to take 157

12 POINT

25 LB FONT \$13 50

GOVERNMENT AND PRINCIPLES
When, in the course of human events, it
becomes necessary for one people to dis-
solve political bands which connect them
with another, and to assume among the
powers of the earth the equal and sepa-
rate station to which the laws of nature
and of nature's God entitle them, a 283

Fonts do not contain spaces and quads

POSTER LIGHTFACE No 158

24 POINT

25 LB FONT \$12 50

FREEDOM DECLARED

When, in time, it becomes
 necessary for one people to
 dissolve the political 54823

20 POINT

25 LB FONT \$13 00

INDEPENDENT CITIZENS

When, in the course of human
 events, it becomes necessary for
 one people to break the political
 bands which have joined them
 with another and to assume 375

18 POINT

25 LB FONT \$13 00

OUR IMPARTIAL PETITIONS

When, in the course of human life
 it becomes necessary for one people
 to break the political bands which
 have joined them with another and
 to assume, among the powers 9283

Fonts do not contain spaces and quads

POSTER LIGHTFACE No 158

12 POINT

25 LB FONT \$13 50

**THE SUSPENSION OF OUR LEGISLATURES
POLITICAL YOKE DISCARDED**

When, in the course of human events, it becomes necessary for one people to dissolve the political bands which have connected them with another, and to assume, among the powers of the earth, the separate and equal station to which the laws of nature and of nature's God entitle them, a decent respect to the opinions of mankind requires 8467

10 POINT

25 LB FONT \$16 25

**BUILDING FOUNDATIONS ON THESE PRINCIPLES
SOLID GOVERNMENT PRESERVED**

When, in the course of human events, it will be found necessary for one people to dissolve the political bands which have joined them with another, and to assume, among the powers of the earth, the separate and equal station to which the laws of nature and of nature's God entitle them, a decent respect to the opinions of mankind requires that they should declare the causes which impel them to the separation. We hold these truths to be self-evident, that all men are created 5672

8 POINT

25 LB FONT \$20 00

**OBSTRUCTING THE LAWS FOR BETTERING OUR CONDITION
THE RIGHTS OF THE PEOPLE PRESERVED**

When, in the course of human events, it becomes necessary for one people to dissolve the political bands which have connected them with another, and to assume, among the powers of the earth, the separate and equal rank to which the laws of nature and of nature's God entitle them, decent regard to the opinions of mankind requires that they should declare the causes which impel them to the separation. We hold these truths to be self-evident, that all men are created equal; that they are endowed by their Creator with certain unalienable rights; that among these, are life, liberty, and the pursuit of happiness. 1234567890

Fonts do not contain spaces and quads

POSTER OLD STYLE ANTIQUE No 153

18 POINT

25 LB FONT \$13 00

PROCLAIMED INDEPENDENCE!

When, in the course of human events, it becomes necessary for one people to dissolve the political bands which have connected them with another, and to assume, among the powers, the equal station to which the laws of nature 42

12 POINT

25 LB FONT \$13 50

FOUNDATIONS LAID ON GOOD PRINCIPLES

When, in the course of human events, it is necessary for one people to dissolve the political bands which connected them with another, and to assume, among the powers of the earth, the separate and equal station to which the laws of nature and of nature's God entitle them, a decent respect to the opinions of mankind requires that they should declare the causes which impel them to the separation. We hold these truths to be self-evident, that all men are created equal; that 46785

10 POINT

25 LB FONT \$16 25

FREEDOM AND LIBERTY

When, in the course of human events, it becomes necessary for one people to dissolve the bands that connect them with another, and to assume, among the powers of the earth, the separate and equal station to which the laws of nature and of nature's God entitle them, a descent respect to the 8910

8 POINT

25 LB FONT \$20 00

SUFFERING OF THE COLONIES

When, in the course of human events, it becomes necessary for one people to dissolve the political bands which have connected them with another, and to assume, among the powers of the earth the separate and equal station to which the laws of nature and of nature's God entitle them, a decent respect to the opinions of mankind requires that they should declare the causes which impel them to the separation. We hold these truths to be self-evident, that all men are created equal; that they are 2586

Fonts do not contain spaces and quads

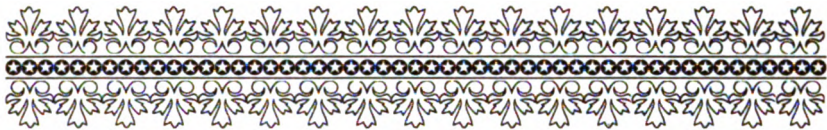

Specimens of...



German
Hebrew
Greek
Rabbinic
Armenian
Russian

*Die Folgenden sind nur einige unserer deutschen
Schriften. Wir haben eine sehr reiche Auswahl und
sind bereit, auf Wunsch Schriftproben vorzulegen.*



American Type Founders Co.

Covering the Continent

SELF SPACING GERMAN *For description of Self Spacing Type, see pages 52 and 53*

6 POINT NO 42

Unit of measure, 12 to Pica

Auf keinem Gebiete waren die Fortschritte seit vier Jahrhunderten so gering wie in der Kunst des Schriftsetzens. Die hier und da in Gebrauch befindlichen Maschinen sind durchaus unvollkommen; die bei weitem größte Masse der üblichen Schrift ist noch genau der Art wie vor vierhundert Jahren. Wenn Franklin heute wieder vor dem Kasten stände, würde er nichts Neues zu lernen haben. Die Schriftgießerei ist hinter der wunderbaren Vervollkommnung der Pressen vollständig zurückgeblieben; die vergrößerte Geschwindigkeit im Schriftsetzen beruht ausschließlich in der Vermehrung der Rasten. Alle Bemühungen, diesem Uebelstande abzuwehren, gingen darauf hinaus, Segmaschinen zu erfinden, statt die Art und Weise des Handsetzens zu verbessern. Eins der Haupthindernisse, welches den Segmaschinen im Wege stand, ist die Notwendigkeit, mit der Hand zu „lustren“. Daran scheiterte hauptsächlich die Einführung dieser Maschinen. Es liegt daher auf der Hand, daß jeder

A B C D E F G H I J K L M N O P Q R S T U V W X Y Z

1234567890

8 POINT NO 43

Unit of measure, 11 to Pica

Auf keinem Gebiete waren die Fortschritte seit vier Jahrhunderten so gering wie in der Kunst des Schriftsetzens. Die hier und da in Gebrauch befindlichen Maschinen sind durchaus unvollkommen; die bei weitem größte Masse der üblichen Schrift ist noch genau der Art wie vor vierhundert Jahren. Wenn Franklin heute wieder vor dem Kasten stände, würde er nichts Neues zu lernen haben. Die Schriftgießerei ist hinter der wunderbaren Vervollkommnung der Pressen vollständig zurückgeblieben; die vergrößerte Geschwindigkeit im Schriftsetzen beruht ausschließlich in der Vermehrung der

A B C D E F G H I J K L M N O P Q R S T U V W X Y Z

1234567890

9 POINT NO 41

Unit of measure, 10 to Pica

Auf keinem Gebiete waren die Fortschritte seit vier Jahrhunderten so gering wie in der Kunst des Schriftsetzens. Die hier und da in Gebrauch befindlichen Maschinen sind durchaus unvollkommen; die bei weitem größte Masse der üblichen Schrift ist noch genau der Art wie vor vierhundert Jahren. Wenn Franklin heute wieder vor dem Kasten stände, würde er nichts Neues zu lernen haben. Die Schriftgießerei ist hinter der wunderbaren Vervollkommnung der Pressen vollständig zurückgeblieben; die vergrößerte Geschwindigkeit im

A B C D E F G H I J K L M N O P Q R S T U V W X Y Z

1234567890

10 POINT NO 40

Unit of measure, 9 to Pica

Auf keinem Gebiete waren die Fortschritte seit vier Jahrhunderten so gering wie in der Kunst des Schriftsetzens. Die hier und da in Gebrauch befindlichen Maschinen sind durchaus unvollkommen; die bei weitem größte Masse der üblichen Schrift ist noch genau der Art wie vor vierhundert Jahren. Wenn Franklin heute wieder vor dem Kasten stände, würde er nichts Neues zu lernen haben. Die Schriftgießerei ist hinter der wun-

A B C D E F G H I J K L M N O P Q R S T U V W X Y Z

1234567890

Smallest font sold, 25 lbs. Prices same as for Roman body type

GERMAN No 121

6 POINT GERMAN No 121

Natur! Wir sind von ihr umgeben und umschlungen—unvermögend, aus ihr herauszutreten, und unvermögend, tiefer in sie hineinzukommen. Ungebeten und ungewarnt nimmt sie uns in den Umlauf ihres Tages auf und treibt sich mit uns fort, bis wir ermüdet sind und ihrem Arme entfallen. Sie schafft ewig neue Gestalten; was da ist, war noch nie; was war, kommt nicht wieder—Jedes ist neu und doch immer das Alte. Wir leben mitten in ihr und sind ihre Freunde. Sie spricht unaufhörlich mit uns und verrät uns ihr Geheimnis nicht. Wir wirken beständig auf sie ein und haben doch keine Gewalt über sie. Große und heilige Natur! in deinen Hallen wandelt der Mensch und lernt von Stauden und Bäumen; sein Auge ruht wie ein Fühlhorn am blauen Himmel, und sucht nach dem, nach welchem sich sein Herz, in der Brust ausstreckt. Dann wird er selbst zum Priester dieses Tempels eingeweiht; mit Thränen endet er die Feierlichkeit. Durch Menschenliebe predigt er andern Menschen, durch Trost, durch Mitleid und Hülfe.—Wer kann die unendliche Liebe nicht fühlen, die über uns ausgepannt ist, und uns auf dieser Welt mit Barmherzigkeit gefangen

abcdefghijklmnopqrstuvwxyz
\$1234 ABCDEFGHIJKLMNOPQRSTUVWXYZ 567890

7 POINT GERMAN No 121

Natur! Wir sind von ihr umgeben und umschlungen—unvermögend, aus ihr herauszutreten, und unvermögend, tiefer in sie hineinzukommen. Ungebeten und ungewarnt nimmt sie uns in den Umlauf ihres Tages auf und treibt sich mit uns fort, bis wir ermüdet sind und ihrem Arme entfallen. Sie schafft ewig neue Gestalten; was da ist, war noch nie; was war, kommt nicht wieder—Jedes ist neu und doch immer das Alte. Wir leben mitten in ihr und sind ihre Freunde. Sie spricht unaufhörlich mit uns und verrät uns ihr Geheimnis nicht. Wir wirken beständig auf sie ein und haben doch keine Gewalt über sie. Große und heilige Natur! in deinen Hallen wandelt der Mensch und lernt von Stauden und Bäumen; sein Auge ruht wie ein Fühlhorn am blauen Himmel, und sucht nach dem,

abcdefghijklmnopqrstuvwxyz
\$1234 ABCDEFGHIJKLMNOPQRSTUVWXYZ 567890

8 POINT GERMAN No 121

Natur! Wir sind von ihr umgeben und umschlungen—unvermögend, aus ihr herauszutreten, und unvermögend, tiefer in sie hineinzukommen. Ungebeten und ungewarnt nimmt sie uns in den Umlauf ihres Tages auf und treibt sich mit uns fort, bis wir ermüdet sind und ihrem Arme entfallen. Sie schafft ewig neue Gestalten; was da ist, war noch nie; was war, kommt nicht wieder—Jedes ist neu und doch immer das Alte. Wir leben mitten in ihr und sind ihre Freunde. Sie spricht unaufhörlich mit uns und verrät uns ihr Geheimnis nicht. Wir wirken beständig auf sie ein und haben doch keine Gewalt über sie. Große und heilige Natur! in deinen

abcdefghijklmnopqrstuvwxyz
\$1234 ABCDEFGHIJKLMNOPQRSTUVWXYZ 567890

9 POINT GERMAN No 121

Natur! Wir sind von ihr umgeben und umschlungen—unvermögend, aus ihr herauszutreten, und unvermögend, tiefer in sie hineinzukommen. Ungebeten und ungewarnt nimmt sie uns in den Umlauf ihres Tages auf und treibt sich mit uns fort, bis wir ermüdet sind und ihrem Arme entfallen. Sie schafft ewig neue Gestalten; was da ist, war noch nie; was war, kommt nicht wieder—Jedes ist neu und doch immer das Alte. Wir leben mitten in ihr und sind ihre Freunde. Sie spricht unaufhörlich mit uns und verrät uns ihr Geheimnis nicht. Wir wirken beständig

abcdefghijklmnopqrstuvwxyz
\$1234 ABCDEFGHIJKLMNOPQRSTUVWXYZ 567890

10 POINT GERMAN No 121

Natur! Wir sind von ihr umgeben und umschlungen—unvermögend, aus ihr herauszutreten, und unvermögend, tiefer in sie hineinzukommen. Ungebeten und ungewarnt nimmt sie uns in den Umlauf ihres Tages auf und treibt sich mit uns fort, bis wir ermüdet sind und ihrem Arme entfallen. Sie schafft ewig neue Gestalten; was da ist, war noch nie; was war, kommt nicht wieder—Jedes ist neu und doch immer das Alte. Wir leben mitten in ihr und sind ihre Freunde. Sie spricht unaufhörlich mit uns und verrät uns ihr Geheimnis nicht. Wir wirken beständig auf sie ein und haben doch keine Gewalt über sie. Große und heilige Natur! in deinen Hallen wandelt der Mensch und lernt von Stauden und

abcdefghijklmnopqrstuvwxyz

§1234 ABCDEFGHJKL MNOPQR STUVWXY Z 567890

11 POINT GERMAN No 121

Natur! Wir sind von ihr umgeben und umschlungen—unvermögend, aus ihr herauszutreten, und unvermögend, tiefer in sie hineinzukommen. Ungebeten und ungewarnt nimmt sie uns in den Umlauf ihres Tages auf und treibt sich mit uns fort, bis wir ermüdet sind und ihrem Arme entfallen. Sie schafft ewig neue Gestalten; was da ist, war noch nie; was war, kommt nicht wieder—Jedes ist neu und doch immer das Alte. Wir leben mitten in ihr und sind ihre Freunde. Sie spricht unaufhörlich mit uns und verrät uns ihr Geheimnis nicht. Wir wirken beständig auf sie ein und haben doch keine Gewalt über

abcdefghijklmnopqrstuvwxyz

§1234 ABCDEFGHJKL MNOPQR STUVWXY Z 567890

12 POINT GERMAN No 121

Natur! Wir sind von ihr umgeben und umschlungen—unvermögend, aus ihr herauszutreten, und unvermögend, tiefer in sie hineinzukommen. Ungebeten und ungewarnt nimmt sie uns in den Umlauf ihres Tages auf und treibt sich mit uns fort, bis wir ermüdet sind und ihrem Arme entfallen. Sie schafft ewig neue Gestalten; was da ist, war noch nie; was war, kommt nicht wieder—Jedes ist neu und doch immer das Alte. Wir leben mitten in ihr und sind ihre Freunde. Sie spricht

abcdefghijklmnopqrstuvwxyz

§1234 ABCDEFGHJKL MNOPQR STU 567890

14 POINT GERMAN NO 121

Natur! Wir sind von ihr umgeben und umschlungen—unvermögend, aus ihr herauszutreten, und unvermögend, tiefer in sie hineinzukommen. Ungebeten und ungewarnt nimmt sie uns in den Umlauf ihres Tages auf und treibt sich mit uns fort, bis wir ermüdet sind und ihrem Arme entfallen. Sie schafft ewig neue

18 POINT GERMAN NO 121

20 A 100 a \$12 48

Natur! Von der Natur umgeben und umschlungen, sind wir unvermögend aus ihr herauszutreten, und unvermögend tiefer in sie hineinzukommen. Ungebeten und ungewarnt nimmt sie uns in

24 POINT GERMAN NO 121

14 A 40 a \$12 00

Natur! Wir sind stets von ihr umgeben und umschlungen, sind unvermögend aus ihr herauszutreten, und unvermögend tiefer

30 POINT GERMAN NO 121

8 A 60 a \$12 00

Von der Natur umgeben und umschlungen, sind wir unvermögend aus ihr

GERMAN No 153

6 POINT GERMAN No 153

Auf keinem Gebiete waren die Fortschritte seit vier Jahrhunderten so gering wie in der Kunst des Schriftsetzens. Die hier und da in Gebrauch befindlichen Maschinen sind durch- aus unvollkommen; die bei weitem größte Masse der üblichen Schrift ist noch genau der Art wie vor vierhundert Jahren. Wenn Franklin heute wieder vor dem Kasten stände, würde er nichts Neues zu lernen haben. Die Schriftsetzerei ist hinter der wunderbaren Vervollkommnung der Pressen vollständig zurückgeblieben; die vergrößerte Geschwindig- keit im Schriftsetzen beruht ausschließlich in der Vermehrung der Kästen. Alle Be- mühungen, diesem Uebelstande abzuhelfen, gingen darauf hinaus, Setzmaschinen zu er- finden, statt die Art und Weise des Handsetzens zu verbessern. Eins der Haupthindernisse, welches den Setzmaschinen im Wege stand, ist die Nothwendigkeit, mit der Hand zu „justiren“. Daran scheiterte hauptsächlich die Einführung dieser Maschinen. Es liegt daher auf der Hand, daß jeder Plan zur Verbesserung unserer Setz-Methoden in erster Linie die Justirung zu vereinfachen hat, denn da dies der Punkt ist, um den sich die Sache

abcdefghijklmnopqrstuvwxyz

\$1234 ABCDEFGHIJKLMNOPQRSTUVWXYZ 567890

8 POINT GERMAN No 153

Auf keinem Gebiete waren die Fortschritte seit vier Jahrhunderten so gering wie in der Kunst des Schriftsetzens. Die hier und da in Gebrauch befind- lichen Maschinen sind durchaus unvollkommen; die bei weitem größte Masse der üblichen Schrift ist noch genau der Art wie vor vierhundert Jahren. Wenn Franklin heute wieder vor dem Kasten stände, würde er nichts Neues zu lernen haben. Die Schriftsetzerei ist hinter der wunderbaren Vervoll- kommung der Pressen vollständig zurückgeblieben; die vergrößerte Geschwin- digkeit im Schriftsetzen beruht ausschließlich in der Vermehrung der Kästen. Alle Bemühungen, diesem Uebelstande abzuhelfen, gingen darauf hinaus,

abcdefghijklmnopqrstuvwxyz

\$1234 ABCDEFGHIJKLMNOPQRSTUVWXYZ 567890

10 POINT GERMAN No 153

Auf keinem Gebiete waren die Fortschritte seit vier Jahrhunderten so gering wie in der Kunst des Schriftsetzens. Die hier und da in Ge- brauch befindlichen Maschinen sind durchaus unvollkommen; die bei weitem größte Masse der üblichen Schrift ist noch genau der Art wie vor vierhundert Jahren. Wenn Franklin heute wieder vor dem Kasten stände, würde er nichts Neues zu lernen haben. Die Schriftsetzerei ist hinter der wunderbaren Vervollkommnung der Pressen vollständig zu-

abcdefghijklmnopqrstuvwxyz

\$1234 ABCDEFGHIJKLMNOPQRSTUVWXYZ 567890

11 POINT GERMAN No 153

Auf keinem Gebiete waren die Fortschritte seit vier Jahrhunderten so gering wie in der Kunst des Schriftsetzens. Die hier und da in Gebrauch befindlichen Maschinen sind durchaus unvollkommen; die bei weitem größte Masse der üblichen Schrift ist noch genau der Art wie vor vierhundert Jahren. Wenn Franklin heute wieder vor dem Kasten stände, würde er nichts Neues zu lernen

abcdefghijklmnopqrstuvwxyz

\$1234 ABCDEFGHIJKLMNOPQRSTUVWXYZ 567890

GERMAN No 155

6 POINT GERMAN NO 155

14 A 42a \$2 25

6 POINT GERMAN NO 155

12 A 36a \$2 50

Natur! Wir sind von ihr umgeben und umschlungen—unvermögend, aus ihr herauszutreten, und unermüdet, tiefer in sie hineinzubringen. Ungebeten und ungewarnt nimmt sie uns in den Umlauf ihres Tages auf und treibt sich mit uns fort, bis wir ermüdet sind und ihrem Arme entfallen. Sie schafft ewig neue Gestalten; was da ist, war noch nie; was war, kommt nicht wieder—Jedes ist neu und doch immer wieder das Alte. Wir leben mitten in ihr und sind ihre

Natur! Wir sind von ihr umgeben und umschlungen—unvermögend, aus ihr herauszutreten, sowie unvermögend, tiefer in sie hineinzukommen. Ungebeten und ungewarnt nimmt sie uns in den Umlauf ihres Tages auf und treibt sich mit uns fort, bis wir ermüdet werden und ihrem Arme entfallen

abcdefghijklmnopqrstuvwxyz

abcdefghijklmnopqrstuvwxyz

\$1234 ABCDEFGHIJKLMNOPQRSTUVWXYZ 567890

\$1234 ABCDEFGHIJKLMNOPQRSTUVWXYZ 567890

9 POINT GERMAN NO 155

12 A 36a \$2 75

Natur! Wir sind von ihr umgeben und umschlungen—unvermögend, aus ihr herauszutreten, und unermüdet, tiefer in sie hineinzubringen. Ungebeten und ungewarnt nimmt sie uns in den Umlauf ihres Tages auf und treibt sich mit uns fort, bis wir ermüdet sind und ihrem Arme entfallen. Sie schafft ewig neue Gestalten; was da ist, war noch nie; was war, kommt nicht wieder—Jedes ist neu und doch immer das Alte. Wir leben mitten in ihr und sind ihre Freunde. Sie spricht unaufhörlich mit uns und ver-

abcdefghijklmnopqrstuvwxyz

\$1234 ABCDEFGHIJKLMNOPQRSTUVWXYZ 567890

10 POINT GERMAN NO 155

10 A 30a \$2 75

Natur! Wir sind von ihr umgeben und umschlungen—unvermögend, aus ihr herauszutreten, und unermüdet, tiefer in sie hineinzukommen. Ungebeten und ungewarnt nimmt sie uns in den Umlauf ihres Tages auf und treibt sich mit uns fort, bis wir ermüdet sind und ihren Armen entfallen. Sie schafft ewig neue Gestalten; was da ist, war noch nie; was war, kommt nicht wieder—Jedes ist neu, jedoch stets das Alte

abcdefghijklmnopqrstuvwxyz

\$1234 ABCDEFGHIJKLMNOPQRSTUVWXYZ 567890

12 POINT GERMAN NO 155

8 A 24a \$3 00

Natur! Wir sind von ihr umgeben und umschlungen—unvermögend, aus ihr herauszutreten oder tiefer in sie einzudringen. Ungebeten und ungewarnt nimmt sie uns in den Umlauf ihres Tages auf und treibt sich mit uns fort, bis wir ermüdet sind und ihrem Arme

abcdefghijklmnopqrstuvwxyz

\$1234 ABCDEFGHIJKLMNOPQRSTUVWXYZ 567890

GERMAN TITLE CONDENSED No 150

72 POINT

3 A 8a \$12 00

Deutsche Treue

60 POINT

4 A 10a \$13 00

Gute Rheinweine

42 POINT

4 A 10a \$10 00

Studenten im Grünen

36 POINT

5 A 15a \$7 75

Waldfräuter

30 POINT

8 A 20a \$6 80

Hochzeitglocken

20 POINT

8 A 24a \$5 75

Columbia Brauerei

18 POINT

9 A 30a \$4 50

Delikates Gabelfrühstück

14 POINT

12 A 40a \$4 00

Das Buch der Natur lag seit
Jahrtausenden aufgeschlagen

12 POINT

16 A 50a \$4 50

Das Buch der Natur liegt für die
Blicke der Menschen aufgeschlagen

11 POINT

16 A 50a \$3 75

Das Buch der Natur lag aufgeschla-
gen vor dem Blicke des Menschen seit

10 POINT

16 A 50a \$3 50

Das Buch der Natur liegt seit Jahr-
tausenden geöffnet vor dem Blicke der

9 POINT

16 A 50a \$3 15

Das Buch der Natur liegt seit Jahrtausen-
den weit aufgeschlagen vor dem Blicke des
1 2 3 4 5 6 7 8 9 0

8 POINT

16 A 50a \$3 00

Das Buch der Natur liegt seit Jahrtausen-
den weit aufgeschlagen vor dem Blicke des
1 2 3 4 5 6 7 8 9 0

GERMAN TITLE No 122

42 POINT

3A 6a \$5 35

Dummer Bagabund

36 POINT

3A 6a \$3 95

Tugend und Freiheit

30 POINT

4A 10a \$4 80

Verschiedene Bemerkung

24 POINT

7A 20a \$4 75

Die Weinstube

18 POINT

7A 20a \$3 50

Nachtschwärmerei

14 POINT

8A 25a \$3 25

**Rühnste Versäumnis
der Wissenschaft und**

12 POINT

9A 30a \$3 10

**Rühne Versäumnis der
Wissenschaft und Kunst**

11 POINT

9A 30a \$2 60

**Das Buch der Natur liegt
seit Jahrtausenden vor den
Blick des Menschen. Es**

10 POINT

12A 40a \$3 00

**Das Buch der Natur liegt
seit Jahrtausenden aufge-
schlagen vor dem Blicke des**

9 POINT

15A 50a \$3 95

**Das Buch der Natur liegt seit
Jahrtausenden vor dem Blicke
des Menschen. Es ist in gro-**

8 POINT

15A 50a \$3 15

**Das Buch der Natur liegt seit
Jahrtausenden vor dem Blicke
des Menschen. Es ist in großen**

7 POINT

15A 50a \$3 10

**Das Buch der Natur liegt seit Jahr-
tausenden aufgeschlagen vor dem
Blicke des Menschen. Es ist in gro-
1234567890**

6 POINT

15A 50a \$2 85

**Das Buch der Natur ist seit Jahrtaus-
den aufgeschlagen vor dem Blicke des Men-
schen. Es ist in großen, herrlichen Jagen
1234567890**

GERMAN FULL FACE

30 POINT

6 A 15 a \$3 00

Neueste Wiener Moden

24 POINT

6 A 15 a \$6 00

Kurverwaltung in Marienbad

18 POINT

7 A 20 a \$4 50

Alter Turnverein

12 POINT

7 A 20 a \$3 00

Lawinen im Hochgebirge

11 POINT

9 A 30 a \$3 00

**Das Buch der Natur ist den
Blicken des Menschen offen**

10 POINT

12 A 40 a \$3 50

**Das Buch der Natur liegt geöff-
net seit Jahrtausenden vor dem**

9 POINT

16 A 50 a \$3 85

**Das Buch der Natur liegt geöffnet
seit Jahrtausenden vor dem Blicke**

8 POINT

16 A 50 a \$3 50

**Das Buch der Natur liegt geöffnet
seit Jahrtausenden vor den Blicken**

7 POINT

16 A 50 a \$3 25

**Das Buch der Natur liegt seit Jahrtau-
senden aufgeschlagen vor der Menschheit.
1 2 3 4 5 6 7 8 9 0**

6 POINT

16 A 50 a \$3 00

**Das Buch der Natur liegt seit Jahrtau-
senden aufgeschlagen vor der Menschheit. 68
1 2 3 4 5 6 7 8 9 0**

TEUTONIC No 150

36 POINT

5 A 12 a \$6 75

Entrüstete Wagnerianer

30 POINT

6 A 15 a \$7 35

Minnesänger beim Turnier

18 POINT

8 A 24 a \$4 75

Starkes Orchester 12

12 POINT

9 A 30 a \$3 00

Prächtige Vorstellungen 34

HEINTZEMANN SERIES

30 POINT

6A 20a \$7 10

Erwiger Kampf um Freiheit

24 POINT

8A 25a \$6 80

Vorsicht ist die Mutter der Weisheit

18 POINT

10A 30a \$4 95

Ein ehrenvoller Name und guter Charakter

14 POINT

12A 40a \$4 80

**Muntere Geister
Biel Humor und Wize**

12 POINT

12A 40a \$3 25

**Ohne Mühe kein Preis
Große Meister schöner Künste**

10 POINT

12A 40a \$2 85

**Reiche Auswahl guter
Materialien und neuester Schriften**

9 POINT

12A 50a \$2 60

**Mit Ehrlichkeit und Fleiß
Kommt man am besten durch die Welt**

8 POINT

15A 50a \$2 60

**Das menschliche Leben bietet dem
Scharfen Beobachter ein gutes Lehrbild
1234567890**

6 POINT

15A 50a \$2 15

**Morgenkünde hat Gold im Grunde
Man soll niemals den Tag vor dem Abend loben
1234567890**

CONDENSED GERMAN BLACK No 150

30 POINT

4A 10a \$3 50

Römisches Soldatenlager im Winter

24 POINT

4A 10a \$2 50

Arabische Elephantenjäger und Sklaventreiber

18 POINT

8A 20a \$3 50

Modernes Sittenbild 56

12 POINT

16A 50a \$4 50

Neue Hamburger Dampferlinien 78

SCHWABACHER SERIES

48 POINT

3 A 8 a \$6 95

Pracht-Gebäude

36 POINT

4 A 8 a \$4 50

Elegante Schrift
Hübsche blaue Farben

30 POINT

5 A 10 a \$3 85

Originelle Novellen
Geschichten und Loblieder

22 POINT

5 A 15 a \$3 15

Tanzschulen
Lustige Knaben

14 POINT

9 A 30 a \$3 20

Schwarze Augen
Bildschöne Zigeunerin

12 POINT

9 A 30 a \$2 35

Berliner Promenaden
Und Anlagen der Umgegend

10 POINT

12 A 40 a \$2 20

Drucksachen für moderne
Zuschneider und alte Dummköpfe

8 POINT

15 A 50 a \$2 65

Nachrichten aus der Heimath
Glänzende Eröffnung der Ausstellung
1234567890

6 POINT

15 A 50 a \$1 95

Die Schriften von Johann Gutenberg
Gleich nach der Erfindung der Buchdruckerkunst
1234567890

SCHWABACHER No 2

48 POINT

3 A 8 a \$11 40

Reiche Fürsten

36 POINT

3 A 8 a \$7 00

Alterthümlichkeit!

30 POINT

4 A 10 a \$6 00

Herrenmeister Zeitung

20 POINT

5 A 15 a \$5 00

**Sieben Herren Kamen Gestern
Deutsche Männer**

16 POINT

6 A 18 a \$4 00

**Es macht der Saft der Purpurtraube
des Menschen Herz gesund**

14 POINT

7 A 20 a \$3 75

**Bekränzt mit Laub
das volle Glas**

12 POINT

8 A 24 a \$3 50

**Des Meeres Gewässer
in Bewegung gesetzt**

10 POINT

10 A 30 a \$3 25

**Preiset unsere Reben
Sagt ein altes Sprichwort
1 2 3 4 5 6 7 8 9 0**

8 POINT

14 A 42 a \$3 00

**Bildung der Menschen
Nach Regen folget Sonnenschein
1 2 3 4 5 6 7 8 9 0**

IHLENBURG SERIES

60 POINT

3 A 5 a \$9 65

Der alte Meister

48 POINT

3 A 8 a \$7 35

Erfinder Gutenberg

36 POINT

4 A 10 a \$5 40

Stammt aus dem sehr alten

24 POINT

5 A 16 a \$3 80

Ritterlichen Geschlecht der Gensfleisch

18 POINT

8 A 25 a \$3 55

Im Jahre 1332 stand sein Urgroßvater, Rathsherr Frielo Gensfleisch, bei dem Aufstande der Zünfte

12 POINT

15 A 45 a \$3 25

Gegen den Adel von Mainz an der Spitze der Patrizier. • Seine zwei Söhne, Peter und Claus, von welchen jener Bürgermeister

10 POINT

16 A 50 a \$3 00

Seitenlinie • • welche nach einem von Peters Gattin G. Gelthus zur Laden zugebrachten Stammhause den Beinamen zur Laden annahm. • • Der Enkel Peters, welcher ebenfalls den

8 POINT

18 A 52 a \$2 70

Wurde und die Hauptlinie des Geschlechts forstsetzte, während dieser eine Seitenlinie stiftete, deren Abkommen in dem Jahre 1432 den Beinamen Sorgenloch oder Selgenloch annahm. • Der Sohn Peters, Frielo, gründete in der Hauptlinie ebenfalls eine

6 POINT

20 A 60 a \$2 40

Namen Frielo führte, nahm die Elise zum Gutenberg, die Erbtochter des mit ihr erlöschenden Geschlechts der Zimmerer zum Gutenberg, zur Gemahlin und zeugte mit ihr zwei Söhne, Frielo und Johann, von welchen der letztere sich Johann Gensfleisch zum Gutenberg nannte, und die vereinigten Namen der beiden alten Geschlechter durch die Erfindung der Buchdruckerkunst den spätesten Nachkommen überliefert hat. • •

GERMANIA No 150

36 POINT

3 A 7a \$6 00

Am Wanderstabe

30 POINT

4 A 10a \$6 00

Reizende Bigenerin

24 POINT

5 A 15a \$5 75

Sehnsucht nach den Alpen

18 POINT

7 A 20a \$5 10

Asyl für obdachlose Schriftsetzer

16 POINT

8 A 24a \$4 50

Bequemes Lager

12 POINT

10 A 30a \$3 90

Prächtige Gebirgsluft

10 POINT

13 A 40a \$3 70

Praktische Unterhaltung
Wald 123 Jelder

9 POINT

14 A 42a \$3 25

Guter Aufenthalt für Kranke
Schon 45 Geheilt

COMPOSITE No 150

30 POINT

6 A 15a \$6 75

Lieder siegreicher Germanen

24 POINT

8 A 20a \$5 75

Auerochshörner

16 POINT

10 A 25a \$4 25

Teutoburger Schlacht

14 POINT

10 A 30a \$3 50

Lagen auf der Bärenhaut
Fischfang 168 Jäger

12 POINT

16 A 50a \$4 50

Und sie tranken stets noch Eines
Arminius 24 Cherusker

HEBREW No 1

10 POINT

JOB FONT #3 60

דְּבָרֵי קִהְלֹת בְּיָדוֹ מֶלֶךְ בִּירוּשָׁלַם: הִבֵּל הַבָּלִים אָמַר קִהְלֹת
 הִבֵּל הַבָּלִים הַכֵּל הָבֵל: מֵהִי־תֵרוֹן לְאָדָם בְּכִלְעֵמְלוֹ שִׁיעֵמַל
 תַּחַת הַשֶּׁמֶשׁ: דוֹר הַלֵּךְ וְדוֹר בָּא וְהָאָרֶץ לְעוֹלָם עֹמֶדֶת: וּזְרַח
 הַשֶּׁמֶשׁ וּבֹא הַשֶּׁמֶשׁ וְאֵל־מְקוֹמוֹ שׁוֹאֵף זְרַח הוּא שֵׁם: הוֹלֵךְ
 אֶל־דְּרוֹם וְסוֹבֵב אֶל־צָפוֹן סוֹבֵב וְסוֹבֵב הוֹלֵךְ הָרוּחַ וְעַל־סִבִּיבֹתָיו

9 POINT

JOB FONT #3 60

דְּבָרֵי קִהְלֹת בְּיָדוֹ מֶלֶךְ בִּירוּשָׁלַם: הִבֵּל הַבָּלִים אָמַר קִהְלֹת הַכֵּל הַבָּלִים הַכֵּל:
 מֵהִי־תֵרוֹן לְאָדָם בְּכִלְעֵמְלוֹ שִׁיעֵמַל תַּחַת הַשֶּׁמֶשׁ: דוֹר הַלֵּךְ וְדוֹר בָּא וְהָאָרֶץ
 לְעוֹלָם עֹמֶדֶת: זְרַח הַשֶּׁמֶשׁ וּבֹא הַשֶּׁמֶשׁ וְאֵל־מְקוֹמוֹ שׁוֹאֵף זְרַח הוּא שֵׁם: הוֹלֵךְ
 אֶל־דְּרוֹם וְסוֹבֵב אֶל־צָפוֹן סוֹבֵב וְסוֹבֵב הוֹלֵךְ הָרוּחַ וְעַל־סִבִּיבֹתָיו שֵׁב הָרוּחַ: כֹּל־
 הַנַּחֲלִים הַלְכִים אֱלֹהִים וְהִים אֵינָנו מֵלֵא אֶל־מְקוֹם שֶׁהַנַּחֲלִים הַלְכִים שֵׁם הֵם שְׂבִים
 לִלְכַת: כֹּל־הַדְּבָרִים יַעֲשִׂים לֹא־יִוָּכַל אִישׁ לְדַבֵּר לֹא־תִשְׁבַּא עַיִן לְרֹאוֹת וּלֹא־תִמְלֵא

8 POINT

JOB FONT #3 60

דְּבָרֵי קִהְלֹת בְּיָדוֹ מֶלֶךְ בִּירוּשָׁלַם: הִבֵּל הַבָּלִים אָמַר קִהְלֹת הַבָּל הַבָּלִים הַכֵּל: מֵהִי־תֵרוֹן
 לְאָדָם בְּכִלְעֵמְלוֹ שִׁיעֵמַל תַּחַת הַשֶּׁמֶשׁ: דוֹר הַלֵּךְ וְדוֹר בָּא וְהָאָרֶץ לְעוֹלָם עֹמֶדֶת: זְרַח הַשֶּׁמֶשׁ
 בָּא הַשֶּׁמֶשׁ וְאֵל־מְקוֹמוֹ שׁוֹאֵף זְרַח הוּא שֵׁם: הוֹלֵךְ אֶל־דְּרוֹם וְסוֹבֵב אֶל־צָפוֹן סוֹבֵב וְסוֹבֵב הוֹלֵךְ
 הָרוּחַ וְעַל־סִבִּיבֹתָיו שֵׁב הָרוּחַ: כֹּל־הַנַּחֲלִים הַלְכִים אֱלֹהִים וְהִים אֵינָנו מֵלֵא אֶל־מְקוֹם שֶׁהַנַּחֲלִים
 הַלְכִים שֵׁם הֵם שְׂבִים לִלְכַת: כֹּל־הַדְּבָרִים יַעֲשִׂים לֹא־יִוָּכַל אִישׁ לְדַבֵּר לֹא־תִשְׁבַּע עַיִן לְרֹאוֹת וּלֹא־
 תִּמְלֵא אֶזֶן מִשְׁמַע: מֵהִשְׁהִיָּה הוּא שִׁיחִיָּה וּמֵהִשְׁנַעֲשֵׂה הוּא שִׁיעֵשָׂה וְאִין כֹּל־חֹרֵשׁ תַּחַת הַשֶּׁמֶשׁ

This size supplied with or without accented letters, as required

6 POINT

JOB FONT #3 60

דְּבָרֵי קִהְלֹת בְּיָדוֹ מֶלֶךְ בִּירוּשָׁלַם: הִבֵּל הַבָּלִים אָמַר קִהְלֹת הַבָּל הַבָּלִים הַכֵּל: מֵהִי־תֵרוֹן
 לְאָדָם בְּכִלְעֵמְלוֹ שִׁיעֵמַל תַּחַת הַשֶּׁמֶשׁ: דוֹר הַלֵּךְ וְדוֹר בָּא וְהָאָרֶץ לְעוֹלָם עֹמֶדֶת: זְרַח הַשֶּׁמֶשׁ וּבֹא
 הַשֶּׁמֶשׁ וְאֵל־מְקוֹמוֹ שׁוֹאֵף זְרַח הוּא שֵׁם: הוֹלֵךְ אֶל־דְּרוֹם וְסוֹבֵב אֶל־צָפוֹן סוֹבֵב וְסוֹבֵב הוֹלֵךְ הָרוּחַ וְעַל־
 סִבִּיבֹתָיו שֵׁב הָרוּחַ: כֹּל־הַנַּחֲלִים הַלְכִים אֱלֹהִים וְהִים אֵינָנו מֵלֵא אֶל־מְקוֹם שֶׁהַנַּחֲלִים הַלְכִים
 שֵׁם הֵם שְׂבִים לִלְכַת: כֹּל־הַדְּבָרִים יַעֲשִׂים לֹא־יִוָּכַל אִישׁ לְדַבֵּר לֹא־תִשְׁבַּע עַיִן לְרֹאוֹת וּלֹא־תִמְלֵא
 אֶזֶן מִשְׁמַע: מֵהִשְׁהִיָּה הוּא שִׁיחִיָּה וּמֵהִשְׁנַעֲשֵׂה הוּא שִׁיעֵשָׂה וְאִין כֹּל־חֹרֵשׁ תַּחַת הַשֶּׁמֶשׁ

Vowel accents not supplied unless specially ordered. With the exception of 8 Point, this series is suitable only for classical work

HEBREW No 2

24 POINT

JOB FONT 83 00

אין דער ערסטען צייט דעם בוכדרוקעם
ווארען דיא בוכדרוקער זעהר אפט אויך
אלס שריפטגייעססער אונד בוכהענדלער

18 POINT

JOB FONT 82 50

אין דער ערסטען צייט דעם בוכדרוקעם ווארען
דיא בוכדרוקער צוגלייך שריפטגייעססער אונד
ניכט זעלטען אויך געלעהרטע. ערסט נאכדעם

12 POINT

JOB FONT 82 50

אין דער ערסטען צייט דעם בוכדרוקעם ווארען דיא בוכדרוקער צוגלייך
שריפטגייעססער, בוכהענדלער אונד ניכט זעלטען אויך געלעהרטע. ערסט
אללמעהליג בילדעטען זיך דיא בוכדרוקעריי אונד דיא שריפטגייעססעריי אלס
זעלבסטשטענדיגע געווערבע אויס, דאגעגען פינדעט זיך פערלענגער אונד

10 POINT

JOB FONT 82 25

אין דער ערסטען צייט דעם בוכדרוקעם ווארען דרוקער צוגלייך שריפטגייעססער,
בוכהענדלער אונד ניכט זעלטען אויך געלעהרטע. ערסט אללמעהליג בילדעטען
זיך דיא בוכדרוקעריי אונד דיא שריפטגייעססעריי אלס זעלבסטשטענדיגע
געווערבע אויס, דאגעגען פינדעט זיך פערלענגער אונד דרוקער נאך יעצט הייפיג

8 POINT

JOB FONT 82 25

אין דער ערסטען צייט דעם בוכדרוקעם ווארען דיא בוכדרוקער צוגלייך שריפטגייעססער, בוכהענדלער אונד
ניכט זעלטען אויך געלעהרטע. ערסט אללמעהליג בילדעטען זיך דיא בוכדרוקעריי אונד דיא שריפטגייעססעריי
אלס זעלבסטשטענדיגע געווערבע אויס, דאגעגען פינדעט זיך פערלענגער אונד דרוקער נאך יעצט הייפיג
אין איינער פערזאן פערזאן פערזאן. דאס בוכדרוקערגעווערבע טראט פון פארן הערזין אלס איינע קונסט אויף
אונד ווארדע אלס זאלכע פון דען געבילדעטען אונד העהערען שטענדיגן געאיכט בערנהארד העסטעלבערג

This series is commonly used for newspapers. Not intended to be used with accents

RABBINIC

12 POINT

PER FONT \$11 60
Font weighs 10 lbs

מאומתי קורין את שמע צערנית. משעה שהכהנים נכנסים לאכול בתרומתן. עד סוף
האשמורה הראשונה דצרי ר' אליאזר. ותכמים אומרים עד חצות. ר"ג אומר עד שיעלה
עמוד השחר. משעה שצאו בניו ונזית המשתה אמרו לו לא קרינו את שמע. אחר להם

10 POINT

PER FONT \$10 40
Font weighs 8 lbs

לך לך מארנך וממולדתך ומזית ארץ אל
הארץ אשר ארצך לתת אותה לך ולבניך כי
שם צאריך הויה ארצך ושם ארעך לגוי גדול
ואגדלה שחך ונצרכו נך כל משפחות הארמה

8 POINT

PER FONT \$12 80
Font weighs 8 lbs

נעל כתר כהונה ערך חלק אחר צמרה מיק י"ג אע"פ
קריה ליה חילוקה כו. הודעתין שבעלי הנמרה נסתפקו
נכ"י המלות אשר זכרום חכמי המשנה וקצרה יד שכלם
ואין ידם משנת ומאין הבין הוניהו המלה משמעותה אור
כל המלות הזרות שצאו על יד צערנהארד העססלצערנ

RUSSIAN No 10

12 POINT

PER LB \$1 16
Smallest font, 25 lbs

Общество Американских Словолитниковъ рекомендуетъ
свой богатый складъ Англійскихъ, Нѣмецкихъ, Грѣче-
скихъ и Еврейскихъ шрифтовъ, сдѣланныхъ изъ самага
лучшаго матеріала. Печатныя и бумаго-рѣзные машины
наилучшей конструкторіи и всякіе типографическіе мате-
ріалы по самымъ дешевымъ цѣнамъ Борисъ Гессельбергъ

ARMENIAN

14 POINT

PER LB \$1 12
Smallest font, 25 lbs

Քաղաքական կացութիւնն ի Հայաստան յոյժ
ծանր է և ճգնաժամական: Հայկական խնդիրն
որ ի բազմաց հետէ դադրած էր զԵւրոպա գրգռելէ

10 POINT

PER LB \$1 30
Smallest font, 25 lbs

Կացութիւնն ի Հայաստան յոյժ ծանր է և ճգնաժամական: Հայկական
խնդիրն որ ի բազմաց հետէ դադրած էր զԵւրոպա գրգռելէ, արդէն
անցած է նախնական աստիճաններն և այսօր առարկայն է որոշման
և խորհրդան Մեծ Պետութեանց: Հայ լիաստն այսօր կը կանգնի

SMALL FONTS OF PORSON AND HEAVYFACE GREEK

PLAN OF PATENTED GREEK CASE

Α	Β	Γ	Δ	Ε	Ζ	Η	α	β	γ	δ	ε	ζ	η	φ
Θ	Ι	Κ	Λ	Μ	Ν	Ξ	ι	κ	λ	μ	ν	ξ	ι	κ
Ο	Π	Ρ	Σ	Τ	Υ	Φ	ο	π	ρ	σ	τ	υ	φ	ο
Χ	Ψ	Ω	Ϝ	ϝ	Ϟ	ϟ	χ	ψ	ω	Ϝ	ϝ	Ϟ	ϟ	χ
α	β	γ	δ	ε	ζ	η	ι	κ	λ	μ	ν	ξ	ο	π
θ	ι	κ	λ	μ	ν	ξ	ο	π	ρ	σ	τ	υ	φ	χ
ο	π	ρ	σ	τ	υ	φ	χ	ψ	ω	Ϝ	ϝ	Ϟ	ϟ	χ
χ	ψ	ω	Ϝ	ϝ	Ϟ	ϟ	χ	ψ	ω	Ϝ	ϝ	Ϟ	ϟ	χ

Price of Greek Case, full size, \$2.00

The want of a small font of Greek type is often felt in printing offices. To meet this need, the American Type Founders Company now puts up small and complete assortments (to include all of the characters used in the largest fonts of Porson Greek), together with a case for same of its own devising. No variations in the assortment or weight of these small fonts will be made. For prices, see specimens. Regular fonts of 50 pounds and upwards will be furnished at pound prices.

Sorts are charged at pound rates in quantities; the minimum charge is 75 cents net. For school examination papers, paragraphs, quotations, etc., these small fonts will prove most useful.

LIST OF PORSON AND HEAVYFACE GREEK LETTERS AND ACCENTS

1 A	15 O	29 ε	43 ς	144 δ	65 η	74 ι	138 ι	96 υ	162 ω	KERNS	116
2 B	16 Π	30 ζ	44 τ	55 δ	66 η	75 ι	139 ι	97 υ	163 ω	103 α	119
3 Γ	17 P	31 η	45 υ	56 δ	67 η	78 ι	84 ι	168 υ	160 ω	104 ε	120
4 Δ	18 Σ	32 θ	46 φ	166 α	68 η	79 ι	87 δ	169 υ	161 ω	105 η	117
5 E	19 T	33 ι	47 χ	140 α	147 η	76 ι	88 δ	156 υ	165 ω	106 ο	118
6 Z	20 T	34 κ	48 ψ	58 ε	148 η	77 ι	89 δ	157 υ	164 ω	107 υ	122
7 H	21 Φ	35 λ	49 ω	59 ε	149 η	80 ι	90 δ	158 υ	142 φ	108 ω	121
8 Θ	22 X	36 μ	133 Ϝ	60 ε	150 η	81 ι	92 δ	98 υ	101 ϐ	109 α	126
9 I	23 Ψ	37 ν	50 δ	61 ε	151 η	85 ι	155 δ	167 υ	102 ϐ	110 η	127
10 K	24 Ω	38 ζ	51 δ	63 ε	70 η	86 ι	91 δ	99 ω	POINTS	111 φ	134
11 A	25 α	39 ο	52 α	146 ε	141 η	82 ι	154 δ	136 ω	129	112	135
12 M	26 β	40 π	143 δ	62 ε	71 ι	83 ι	93 υ	100 ω	130	113	125
13 N	27 γ	41 ρ	54 δ	145 ε	72 ι	152 ι	94 υ	159 ω	131	114	123
14 Ξ	28 δ	42 σ	57 δ	64 η	73 ι	153 ι	95 υ	137 ω	132	115	124

When ordering sorts quote number as well as letter. No sorts for less than 75 cents, net.

INFORMATION RESPECTING GREEK TYPE

The Greek Alphabet contains twenty-four letters: seventeen consonants and seven vowels. The only duplicate characters are σ and ς, the latter being used as a final letter only. The accents and breathings are:

- Smooth
- Acute
- Circumflex
- Rough
- Grave
- Smooth acute
- Smooth grave
- Rough acute
- Rough grave
- Smooth circumflex
- Rough circumflex
- Diæresis
- Diæresis acute
- Diæresis grave

The sign of interrogation is made by a [;], the colon by an inverted full point [·]; the other points are the same as in English. The kerned letters are seldom required, and are only supplied to a font to make up any deficiency in accented sorts. Accented caps have the accent before them, thus [•Ω]. The figures used are the same as in English, and are not put up with job fonts.

Compositors should bear in mind that no accent can be placed over any other than one of the last three syllables of a word. The grave accent never occurs but on the last syllable; this being the case, the rough grave [•] and smooth grave [•] can only be used for a few monosyllables. No vowels can have a breathing excepting at the beginning of the word, and ϐ is the only consonant marked by a breathing. Almost every word has an accent, but very few more than one.

PORSON GREEK

Porson Greek cast to order in fonts of 50 lbs. and upwards

8 POINT

JOB FONT 87 50

Τοῦ δ' ἐπιγεγυμμένου θέρου αἱ μὲν ἐνιαύσιοι σπονδαὶ διελέλυτο μέχρι Πυθίων· καὶ ἐν τῇ ἐκεχειρίᾳ οἱ Ἀθηναῖοι Δηλίου ἀνέστησαν ἐκ Δήλου, ἡγησάμενοι κατὰ παλαιὰν τινα αἰτίαν οὐ καθαρῶς ὄντας ἱερῶσθαι, καὶ ἅμα ἔλλιπές σφίσις εἶναι τοῦτο τῆς καθάρσεως, ἣ πρότερόν μοι δεδήλωται ὡς ἀνελόντες τὰς θήκας τῶν τεθνεώτων ὀρθῶς ἐνόμισαν ποιῆσαι. καὶ οἱ μὲν Δῆλιοι Ἀτραμύττειον Φαρνάκου δόντος αὐτοῖς ἐν τῇ Ἀσίᾳ ῥήσαν, οὕτως ὡς ἕκαστος ὄρμητο. Κλέων δὲ Ἀθηναῖος πείσας ἐς τὰ ἐπὶ Θράκης χωρία ἐξέπλευσε μετὰ τὴν ἐκεχειρίαν, Ἀθηναίων μὲν ὀπλίτας ἔχων διακοσίους καὶ χιλιούς καὶ ἵππείας τριακοσίους, τῶν δὲ ξυμμάχων πλείους, ναῦς δὲ

8 Point Porson Greek cast on 9 Point to order in fonts of 50 lbs. and upwards

10 POINT

JOB FONT 87 50

Ἄλλο δὲ στράτευμα αὐτῷ συνελέγετο ἐν Χερρονήσῳ τῇ καταντιπέρας Ἀβύδου τόνδε τὸν τρόπον. Κλέαρχος Λακεδαιμόνιος φυγάς ἦν· τούτῳ συγγενόμενος ὁ Κῦρος ἠγάσθη τε αὐτὸν καὶ δίδωσιν αὐτῷ μυρίους δυρεικούς. ὁ δὲ λαβὼν τὸ χρυσίον στράτευμα συνέλεξε ἀπὸ τούτων τῶν χρημάτων, καὶ ἐπολέμει ἐκ Χερρονήσου ὀρμύμενος τοῖς Ὀπαξί τοῖς ὑπὲρ Ἑλλησποντον οἰκοῦσι, καὶ ὠφέλει τοὺς Ἑλληνας. ὥστε καὶ χρήματα συνεβάλλοντο αὐτῷ εἰς τὴν τροφήν τῶν στρατιωτῶν αἱ Ἑλλησποντικαὶ πόλεις ἐκούσαι. τοῦτο δ' αὐ οὕτω τρεφόμενον ἐλάνθανεν αὐτῷ τὸ στράτ-

11 POINT

JOB FONT 87 50

Ἐπεὶ δὲ ἦσαν ἐν τῇ ἄνω χώρα οἱ Ἑλληνες, ὅποια τῶν χωρίων τοῖς Δρίλαις ἀλώσιμα εἶναι ἐδόκει, ἐμπιπράντες ἀπήεσαν· καὶ οὐδὲν ἦν λαμβάνειν, εἰ μὴ ὕς ἢ βούς ἢ ἄλλο τι κτήνος τὸ πύρ διαπεφευγός. Ἐν δ' ἦν χωρίον μητρόπολις αὐτῶν· εἰς τοῦτο πάντες συνεῤῥύηκεσαν. Περὶ δὲ τοῦτο ἡ χαράδρα ἰσχυρῶς βαθεῖα, καὶ πρόσοδοι χαλεπία πρὸς τὸ χωρίον. Κοτυωρίτας δέ, οὓς ὑμετέρους φατ' εἰνανεῖε, τι αὐτῶν εἰλήφαμεν, αὐτοὶ

12 POINT

JOB FONT 87 50

Ἄλλα γὰρ οὐ τὰ μέλλοντα ἔσεσθαι βούλομαι λέγειν,πραχθέντα ὑπὸ τούτων οὐ δυνάμενος εἰπεῖν· οὐδὲ γὰρ ἀπώλεσε. τιμώμενος δὲ καὶ τῶν μεγίστων ἀξιούμενος, αὐτὸς ἐπαγγεῖλάμενος σώσειν τὴν πόλιν αὐτὸς ἀπώλεσε, φάσκων τὴν πρᾶγμα ἠύρηκεναι μέγα καὶ πολλοῦ ἄξιον. ὑπέχετο δὲ εἰρήνην ποιήσειν μήτε ὄμηρα δούς μήτε τὰ τείχη καθελὼν μήτε τὰς ναῦς παραδούς· ταῦτα δὲ εἰπεῖν

GREEK TYPE

12 POINT

Smallest font, 15 lbs

PER LB #1 18

Καὶ οἱ μὲν ἀμφὶ τὸν Κῦρον, δειπνοποιησάμενοι καὶ φύλακας καταστησάμενοι, ὠνυπερ ἔδει, ἐκοιμήθησαν. Κροῖσος μέντοι εἰδὺς ἐπὶ Σάρδεων ἔφηνε σὺν τῷ στρατεύματι τὰ δ' ἄλλα φύλα ὅποιοι ἐδύνατο προσωτάτω ἐν τῇ νυκτὶ τῆς ἐπ' οἶκον ὁδοῦ ἕκαστος ἀπεχώρει. Ἐπεὶ δὲ ἡμέρα ἐγένετο, εἰδὺς

ἀείμνηστος (μιμνήσκω) ever-memorable ; ἀεκούσιος (ἐκούσιος) involuntary ; ἀθανασία, immortality ; Ἀθῆναι, ὦν, αἶ, Athens ; Ἀθηναίη, Ἀθηναῖα ; ἀδλητής, contend ; ἀδροῖζω, assemble ; ἀδρός, full ; ἀδυμέω, dejected ; αἰγανέα, javelin ; αἰγειρος, poplar ; Αἴγινα, Ægina ; Αἴγυπτος, Egypt ;

11 POINT

Smallest font, 15 lbs

PER LB #1 22

δ' ἐγένετο πρὸς τῷ τείχει τῷ ἐν Σάρδεσι, τὰς τε μηχανὰς ἀνίστη, ὡς προσβαλὼν πρὸς τὸ τείχος, καὶ κλίμακας παρεσκευάζετο. Ταῦτα δὲ ποιῶν, κατὰ τὰ ἀποτομώτατα δοκῶντα εἶναι τοῦ Συρδαιανῶν ἐρύματος τῆς ἐπιούσης νυκτός ἀναβιβάζει Χαλδαίους τε καὶ Πέρσας. Ἠγήσατο δ' αὐτοῖς ἀνὴρ Πέρσης, δούλος γεγεννημένος τῶν ἐν τῇ ἀχροπόλει τινὸς φρουρῶν, καὶ καταμεμαθηκώς

αἰδώς, shame ; αἰετός for ἀετός ; αἰθάλη, ashes ; αἰκία, suffering ; αἶλος, wailing ; αἵματώ, stain with blood ; αἴνγμα, enigma ; αἰνigmatώδως, obscure ; αἰνῆμαι, to take ; αἰπύς, high ; αἰρέω, to kill ; αἰσθάνομαι, to perceive ; αἰσχος, disgrace ; αἰσχροκέρδεα, love of lucre ; αἰσχρός, shameful ; αἰσχύνη, shame ; αἰτεόμοι, to accuse ; αἰχμάλωτος, captive ;

10 POINT No 2

Smallest font, 15 lbs

PER LB #1 30

βασιν τὴν αὐτήν. Ὡς δὲ ἐγένετο τοῦτο δῆλον, ὅτι εἶχετο τὰ ἄκρα, πάντες δὲ ἔφηνον οἱ Ἀσδοὶ ἀπὸ τῶν τειχῶν, ὅπη ἡδύνατο ἕκαστος τῆς πόλεως. Κῦρος δὲ ἅμα τῇ ἡμέρᾳ εἰσῆει εἰς τὴν πόλιν, καὶ παρήγγειλεν ἐκ τῆς τάξεως μηδένα κινεῖσθαι. Ὁ δὲ Κροῖσος, κατακλεισάμενος ἐν ταῖς βασιλείαις, Κῦρον ἐβόα ὅ δὲ Κῦρος τοῦ μὲν Κροῖσου φύλακας κατέλιπεν, αὐτὸς δὲ ἀπαγαγὼν πρὸς τὴν ἐχομένην ἄκραν, ὡς εἶδε τοὺς μὲν Πέρ-

ἀέστρα, a needle ; ἀκήρατος, incorrupt ; ἄκις, infirm ; ἀκίνδυνος, free from danger ; ἀκινδύνως, to be safe ; ἀκίνητος, immovable ; ἀκμὴν, as yet ; ἀκούτης, husband ; ἀκόλαστος, a profligate ; ἀκολουθέω, to imitate ; ἄκος, healing ; ἀκούω, to hear ; ἀκροάομαι, to obey ; ἀκρόασις, audibility ; ἄκρος, lofty ; ἀκρωτήριον, summit ; ἀκύμων, waveless ; ἀλαζών, bragging ; Ἀλαί, Alæ ; ἀλάομαι, to wander ; ἀλαωτός,

GREEK TYPE

8 POINT No 2

Smallest font, 15 lbs

PER LB \$1 80

δεδραμήκεσαν γὰρ ἄρπασόμενι τὰ ἐκ τῶν οἰκῶν, εὐθὺς συνεκάλεσεν αὐτῶν τοὺς ἀρχοντας, καὶ εἶπεν αὐτοῖς ἀπέναντι ἐκ τοῦ στρατεύματος ὡς τάχιστα. "Οὐ γὰρ ἂν," ἔφη, "ἀνασχοίμην πλεονεκτοῦντας ὀρῶν τοὺς ἀτακτοῦντας. Καὶ εὐ μὲν," ἔφη, "ἐπίστασθε, ὅτι παρεσκευασόμεν ἔγω ὑμᾶς τοὺς ἐμοὶ συστρατευομένους πᾶσι Χαλδαίοις μακαριστοὺς ποιῆσαι· νῦν δ'," ἔφη, "μὴ θαναμάζετε, ἦν τις καὶ ἀπίοισιν ἴμιν κρείττων ἐντύχηρ." Ἄκουσαντες ταῦτα οἱ Χαλδαῖοι ἐδεδίοντο τε καὶ ἰκέτερον παύσασθαι ὀργιζόμενον, καὶ τὰ χρήματα πάντα ἀποδώσειν ἔφασαν. Ὁ δὲ εἶπεν, ὅτι οὐδὲν αὐτῶν ἴδεο. "Ἄλλ' εἰ με," ἔφη, "βοίλευσε παύσασθαι ἀχθόμενον, ἀπόδοτε πάντα, ὅσα ἐλαβετε, τοὺς διαφύλαξασι

ἀλιεῖς, fisherman; ἀλίως, to salt; ἄλιος, marine; ἄλισκω, to capture; Ἄλκιβιάδης, Alcibiades; ἄλλα, however; ἄλλασσω, to change; ἄλλαχθί, otherwise; ἄλλῃ, elsewhere; ἀλλήλων, one another; ἄλλοκοτος, monstrous; ἄλλος, other; ἀλλόφυλος, foreign; ἀλμη, brine; ἀλμυρός, salt; ἄλογος, irrational; ἀλώπηξ, fox; ἀμαθής, ignorant; ἀμαξίτιος, highway; ἀμαρτανω, to err; ἄμω, to mow; ἀμβολας, mound; ἀμείβω, to pass; ἀμέλω, to milk; ἀμέλει, truly; ἀμελής, careless; ἀμέμπτως, blamelessly; ἀμεννός, enfeebled; ἀμέτρητος, unmeasured; ἀμετρος, immense; ἀμίλλα, strife; ἀμίλλαροι, endeavor; ἀμνημονεύω, to for-

7 POINT No 2

Smallest font, 10 lbs

PER LB \$1 80

πάντα μοι καλῶς ἔξει. Οἱ μὲν δὲ Χαλδαῖοι οὕτως ἐποίησαν, ὡς ἐκέλευσεν ὁ Κύριος· καὶ ἔλαβον οἱ πειδομένοι πολλὰ καὶ παντοία χρήματα. Ὁ δὲ Κύριος καταστρατοπεδεύσας τοὺς ἑαυτοῦ, ὅπου ἐδόκει ἐπιτηδεύοντες εἶναι τῆς πόλεως, μὲνεν εἰς τοὺς ὅπλοις παρηγόρευε καὶ ἀριστοποιοῖσθαι. Ταῦτα διαπραξάμενος, ἀγαγεῖν ἐκέλευσεν αὐτῶ τὸν Κροῖσον. Ὁ δὲ Κροῖσος ὡς εἶδε τὸν Κύριον, Χαίρει, ὦ δέσποτα, ἔφη· τοῦτο γὰρ ἡ τύχη καὶ ἔχειν τὸ ἀπὸ τοῦδε δίδωσί σοι, καὶ ἐμοί, προσαγορεύειν. Καὶ σὺ γε, ἔφη, ὦ Κροῖσε· ἐπέιπερ ἄνθρωποι ἔσμεν ἀμόφοροι. Ἄτάρ, ἔφη, ὦ Κροῖσε, ἀρ' ἂν τί μοι ἐτελήσῃς συμβουλευσαι; Καὶ βουλοίμην γ' ἂν, ἔφη, ὦ Κύριε, ἀγαθὸν τί σοι εὐρεῖν· τοῦτο γὰρ ἂν οἶμαι ἀγαθὸν κάμοι γενέσθαι. Ἄκουσον τοῦτον, ἔφη, ὦ Κροῖσε· ἐγὼ γὰρ ὀρῶν τοὺς στρατιώτας πολλὰ

ἀμφιθαίνω to surround; ἀμφίβολος ambiguous; ἀμφιγνοῦς to feel doubtful; ἀμφικρύπτω to envelope; ἀμφίπολος domestic; ἀμφισβητέω to wrangle; ἀμφιφορεύς amphora; ἀμφω, ἀμφοῖν the two; ἀμωμος spotless; ἀναβαίνω to ascend; ἀναβάλλω to put off; ἀνάβασις peregrination; ἀναβίωω resuscitate; ἀναβλέπω behold; ἀναγιγνώσκω recognize; ἀναγκάω oblige; ἀναγκαῖος necessary; ἀνάγκη unavoidable; ἀναγκυή departure; ἀναδέω to bind; ἀναδίδωμι yield up; ἀναδιπλώω to fold over; ἀναδινομαι to shrink; ἀναθάλλω cherish; ἀνάθημα gift; ἀναίμοσμος bloodless; ἀναίνομαι to disavow; ἀναίρεσις removal; ἀναίρω demolish; ἀναίσχυντος shameful; ἀνακαίω to burn; ἀνακαλύπτω to unveil; ἀνάκειμαι recline; ἀνακλαίω to lament; ἀνάκλη-

6 POINT No 2

Smallest font, 10 lbs

PER LB \$2 00

στρατιώτας. Γινώσκω γὰρ, ἔφη, ὅτι, εἰ μὴ τινα καρπὸν λήψονται ἐκ τῶν πόρων, οὐ δυνήσομαι αὐτοὺς πολλὸν χρόνον πειδομένους ἔχειν. Διαρπάσαι μὲν οὖν αὐτοὺς ἐφείναι τὴν πόλιν οὐ βούλομαι· τὴν τε γὰρ πόλιν νομίζω ἂν διαφθάρηται, ἐν τε τῇ ἀρπαγῇ οὐδ' ὅτι οἱ πονηρότατοι πλεονεκτήσαν ἂν. Ἄκουσαι ταῦτα ὁ Κροῖσος ἔλεξεν, Ἄλλ' ἐμε, ἔφη, ἔασον λέξαι, πρὸς οὓς ἂν ἐγὼ Λυδῶν ἐθέλω, ὅτι διαπέπραγμα παρά σου μὴ ποιῆσαι ἀρπαγὴν, μηδὲ ἔασαι ἀφαιρῶσθαι παῖδας καὶ γυναῖκας· ὑπεσχόμεν δὲ σοι ἀντί τούτων, ἢ μὴν παρ' ἐκόντων Λυδῶν ἔσσεσθαι πᾶν, ὅ τι καλὸν κάγαθόν ἐστιν ἐν Σάρδεις. Ἦν γὰρ ταῦτα ἀκούσων, οἶδ' ὅτι ἤξει σοι πᾶν, ὅ τι ἐστὶν ἐνθάδε καλὸν κτήμα ἀνδρὶ καὶ γυναικί· καὶ ὁμοίως εἰς νέωτα πολλῶν καὶ καλῶν κάλιν σοι πλῆρης ἡ πόλις ἔσται. Ἦν δὲ διαρπάσης, καὶ αἱ τέχνηαι σοι, ἀε πηγὰς φασ τῶν καλῶν εἶναι, διεφθάρμεναι ἔσονται. Ἐξέστα δὲ σοι ἰδόντι ταῦτα ἐλθόντα ἐτι καὶ περὶ

ἀναλογίζομαι reflect; ἀναλύω to solve; ἀναμένω expect; ἀνάμερος rude; ἀναμνησκω recollect; ἀνάμνησις recollection; ἀναμφισβήτητος indubitable; ἀνανδός effeminate; ἀναξ king; ἀνάξις unworthy; ἀναπάλλω shake; ἀναπαυσις rest; ἀναπαύω refresh; ἀναπειθῶ to convince; ἀναπέμψω to send; ἀναπηδάω leap out; ἀναπλάσσω to form; ἀναπέω return; ἀναπέωσιν filled up; ἀναπνεῶ take breath; ἀναπνοή breathing; ἀναρῶς feeble; ἀναριθμῶς count; ἀναριθμῶς numberless; ἀναρχία anarchy; ἀνάσσω command; ἀνάστασις departure; ἀνάστατος torn up; ἀναστρέφω to sob; ἀναστρέφω to turn; ἀνατέλλω to rise; ἀνατιθέμι to dedicate; ἀνατινάσσω to fling up; ἀνατρέπω subvert; ἀνατρέφω to nourish; ἀνατρέχω run again; ἀναφεύγω to flee; ἀναφύσσω to exhale; ἀναχωρέω to recede; ἀναχωρήσις retreat; ἀνδραγαθία valor; ἀνδραποδιάω to enslave

We also make 9 Point and 4½ Point, to order only

HEAVYFACE GREEK

Heavyface Greek cast to order in fonts of 50 lbs. and upwards

8 POINT

JOB FONT #7 50

Ὀκοῦν οὐδ' ἂν εἰς ἀντίποι ὡς οὐ συμ-
 φέροι τῇ πόλει καὶ Λακεδαιμονίους ἀσ-
 θενεῖς εἶναι καὶ Θηβαίους τούτουςι. Ἔστι
 τοίνυν ἔν τινι τοιοῦτῳ καιρῷ τὰ πράγ-
 ματα νῦν εἴ τι δεῖ τοῖς εἰρημένοις πολλὰκις
 παρ' ὑμῖν λόγοις τεκμήρασθαι, ὥστε Θη-
 βαίους μὲν Ὀρχομενοῦ καὶ Θεσπιῶν καὶ
 Πλαταιῶν οἰκισθεῖσάν ἀσθενεῖς γενέσθαι,
 Λακεδαιμονίους δέ, εἰ ποιήσονται τὴν
 Ἀρκαδίαν ὑφ' ἑαυτοῖς καὶ Μεγάλην πόλιν

κτείνω, f. κτενώ (§120, 1), a. ἐκτεῖνα (§121),
 pf. ἐκτανον (§109, 3) (ἀποκτείνω is gen-
 erally used), to kill.

Κτησίας, -ου, (ὁ), Ctesias, a Greek physi-
 cian at the Persian court.

Κύδνος, -ου, (ὁ), Cydnus, a river in Cilicia,
 flowing through the city of Tarsus.

κύκλος, -ου, (ὁ), a circle; κύκλω, in a circle.

Eng. CYCLE.

κυκλώω, (ᾶ), f. -ώσω, to encircle, surround.

11 POINT

JOB FONT #7 50

Βοηθήσαντες δὲ ἐς αὐτὸ Πασιτελίδας τε ὁ Λακεδαιμόνιος ἄρχων
 καὶ ἡ παρούσα φυλακὴ προσβαλόντων τῶν Ἀθηναίων ἡμύνοντο. καὶ
 ὡς ἐβιάζοντο καὶ αἱ νῆες ἅμα περιέπλεον ἐς τὸν λιμένα περιπεμφθεῖσθαι,
 δέισας ὁ Πασιτελίδας μὴ αἰ τε νῆες φθάσωσι λαβοῦσαι ἐρήμον τὴν πόλιν
 καὶ τοῦ τειχίσματος ἀλίσκομένου ἐγκαταληφθῆ, ἀπολιπὼν αὐτὸ δρόμῳ
 ἐχώρει ἐς τὴν πόλιν. οἱ δὲ Ἀθηναῖοι φθάνουσιν οἱ τε ἀπὸ τῶν νεῶν
 ἐλόντες τὴν Ἰωνίαν καὶ ὁ πεζὸς ἐπισπόμενος αὐτοβοεῖ κατὰ τὸ

INSCRIPTION GREEK

10 POINT

30 A #4 80

ΡΗΞΑΝΤΑΨΙΡΑΦΥΛΛΞΑΝΤΑ
 ΠΑΝΛΦΥΡΑΦΥΛΛΞΑΝΤΑ
 ΤΑΜΙΕΥΞΑΝΤΑΔΕΚΑΠΤΕΥΞΑΝΤΑ
 ΓΡΑΜΜΑΤΕΥΞΑΝΤΑΚΑΙΤΗΦΙΛΟΣΕΒΑΣΤΟΥ
 ΓΕΡΟΥΞΙΑΞΚΑΙΤΩΝΦΙΛΟΣΕΒΑΣΤΩΝ
 ΝΕΨΗΝΚΑΙΡΩΜΑΙΨΗΝΥΠΟΣΧΟΜΕΝΟΝ
 ΚΑΙΕΙ>ΤΗΝΑΛΟΡΑΝΚΙΟΝΑΣΕΙΚΟΣ

GREEK LETTERS

30 CTS EACH

Order by name and number

1	2	3	20	21	22	23	24	25	26	27	28
Λ	Σ	Ω	Ψ	Σ	Γ	Ξ	Φ	Π	Θ	Λ	Ω
Lambda	Sigma	Omega	Psi	Sigma	Gamma	Xi	Phi	Pi	Theta	Lambda	Omega

EXCELSIOR MUSIC

PER LB \$3 60
Weight of smallest font, 15 lbs

THE STAR-SPANGLED BANNER

FRANCIS SCOTT KEY. 1814

Voices in unison

Oh, say, can you see, by the dawn's early light, What so proud-ly we hail'd at the

twilight's last gleaming, Whose stripes and bright stars, thro' the perilous fight, O'er the ramparts we

EXCELSIOR MUSIC No 2

PER LB \$3 60
Weight of smallest font, 15 lbs

MY COUNTRY! 'TIS OF THEE

SAMUEL F. SMITH

H. CAREY

My country! 'tis of thee, Sweet land of lib - er - ty, Of thee I sing; Land where my

fa - thers died! Land of the Pilgrims' pride! From ev - 'ry mountain side Let free-dom ring!

EXCELSIOR MUSIC No 3

PER LB \$3 60
Weight of smallest font, 15 lbs

OLD HUNDRED

ISAAC WATTS

G. FRANC

Be - fore Je - ho - vah's aw - ful throne, Ye na - tions! bow with sa - cred joy:

DIAMOND MUSIC No 1

PER LB \$3 20
Weight of smallest font, 30 lbs

HOME, SWEET HOME

BISHOP

With expression

Mid pleas-ures and pal - a - ces though we may roam, Be it ev - er so

hum - ble, there's no place like home! A charm from the skies seems to hal - low us

cres.

DIAMOND MUSIC No 2

PER LB \$3 20
Weight of smallest font, 30 lbs

ANNIE LAURIE

SCOTCH BALLAD

Tenderly

Max - wel - ton's braes are bon - nie, Where ear - ly fa's the dew,

And 'twas there that An - nie Lau - rie Gave me her prom - ise true,

DIAMOND MUSIC No 3

PER LB \$3 20
Weight of smallest font, 30 lbs

AULD LANG SYNE

ROBERT BURNS

p *Slow*

Should auld ac-quaint-ance be for - got, And nev - er brought to mind?

Should auld ac-quaint-ance be for - got, And days of auld lang syne?

DIAMOND MUSIC No 4

PER LB \$3 20
Weight of smallest font, 30 lbs

Novello, or English Note

WATCH ON THE RHINE

WILHELM

Therewells a cry as thun - ders crash, As clash of swords and break - ers dash; To

Rhine, to Rhine, to the Ger - man Rhine, Who will pro - tect thee riv - er mine?

AGATE MUSIC No 3

VIVA L'AMERICA, HOME OF THE FREE

PER LB #2 40
Weight of smallest font, 30 lbs

H. MILLARD

Marchite

ff

Ped.

p

Man.

Detailed description: This is a musical score for a march. It consists of two staves, treble and bass clef. The key signature has one sharp (F#) and the time signature is 2/4. The piece is marked 'Marchite' and 'ff' (fortissimo). It features a variety of rhythmic patterns, including eighth and sixteenth notes, and rests. There are dynamic markings 'p' (piano) and 'Man.' (marcato) towards the end of the piece. Pedal markings 'Ped.' are present under the first and second staves.

NONPAREIL MUSIC No 3

EVER BE HAPPY

PER LB #2 00
Weight of smallest font, 30 lbs

BALFE

Allegretto Moderato

mf

Detailed description: This is a musical score for a piece titled 'Ever Be Happy'. It consists of two staves, treble and bass clef. The key signature has one flat (Bb) and the time signature is 2/4. The piece is marked 'Allegretto Moderato' and 'mf' (mezzo-forte). The melody is primarily composed of eighth and sixteenth notes. There are some rests and a final flourish at the end of the piece.

UNITED STATES SIGNAL FLAGS

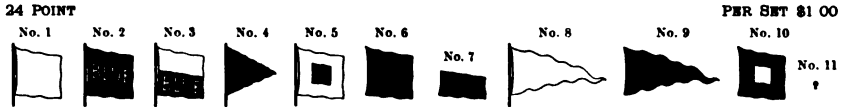
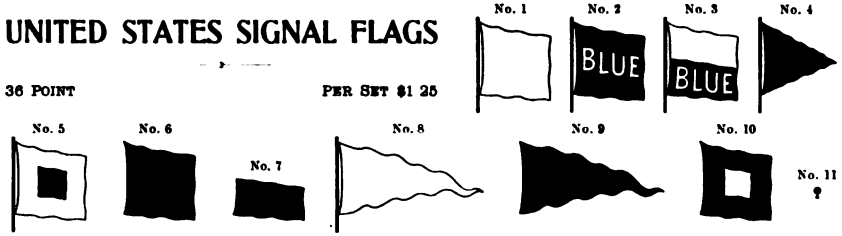

EXPLANATION OF WEATHER SIGNALS

Clear or Fair Weather.—WHITE, SQUARE FLAG. Print No. 1 in black. Displayed alone, indicates fair weather, stationary temperature; displayed with No. 4 above it, indicates fair weather, warmer; displayed with No. 4 below it, indicates fair weather, colder.

Rain or Snow.—BLUE, SQUARE FLAG. Use No. 2, or print No. 6 in blue over No. 1 in black. Displayed alone, indicates rain or snow, stationary temperature; displayed with No. 4 above it, indicates rain or snow, warmer; displayed with No. 4 below it, indicates rain or snow, colder.

Local Rain.—WHITE AND BLUE, SQUARE FLAG. Use No. 3, or print No. 7 in blue over lower half of No. 1 in black. Displayed alone, indicates local rain, stationary temperature; displayed with No. 4 above it, indicates local rain, warmer; displayed with No. 4 below it, indicates local rain, colder.

Temperature Signal.—BLACK, TRIANGULAR FLAG. Print No. 4 in black. Displayed in conjunction with other signals, as above described.

Cold Wave.—WHITE, SQUARE FLAG, BLACK CENTER. Print No. 5 in black. Displayed alone indicates temperature will fall 20° or more, to a minimum of 32° or less. When displayed with No. 1, indicates fair weather, cold wave.

EXPLANATION OF WIND SIGNALS

Storm.—RED, SQUARE FLAG, BLACK CENTER. Print No. 10 in red over No. 5 in black. When displayed, indicates that storm of marked violence is expected. **Hurricane.**—Indicated by two Storm Flags displayed one above the other.

Cautionary.—RED, SQUARE FLAG, WHITE CENTER. Print No. 10 in red over No. 1 in black. When displayed, indicates that the winds expected will not be so severe. Well-found, seaworthy vessels can meet them without danger.

Easterly Winds.—RED PENNANT. Print No. 9 in red over No. 8 in black. When displayed above either Cautionary or Storm Flags, indicates northeasterly winds; when below, southeasterly; when alone, that special information of storms is to be obtained by calling on Signal Officer in charge.

Westerly Winds.—WHITE PENNANT. Print No. 8 in black. Displayed above either Cautionary or Storm Flags, indicates northwesterly winds; below, southwesterly.

WEATHER INDICATORS

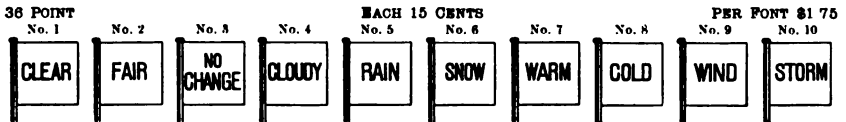

ENGRAVING BLANKS

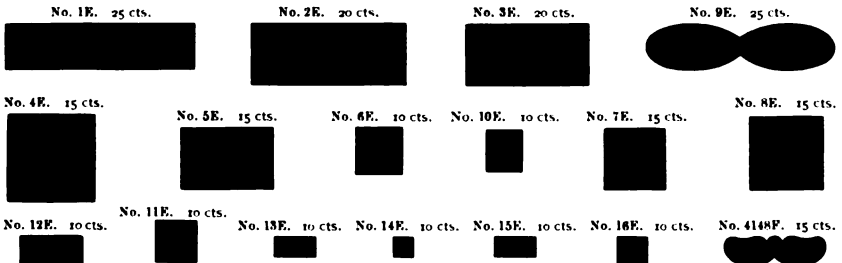

CHESSMEN AND CHECKERS

24 POINT CHESSMEN

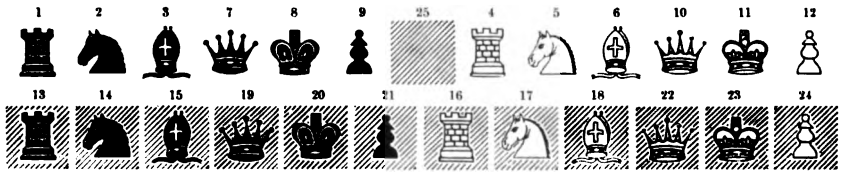

20 POINT CHESSMEN



PER FONT WITH RULES \$4 80



16 PT CHECKERS

PER FONT WITH RULES \$3 40



20 PT CHECKERS

PER FONT WITH RULES \$3 40



24 PT CHECKERS

PER FONT WITH RULES \$3 40



16 PT CHESSMEN

PER FONT WITH RULES \$4 80

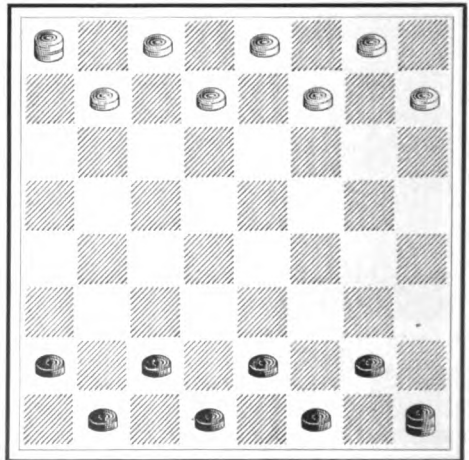

11 POINT CHECKERS



PER FONT WITH RULES \$2 00

CARD PIPS

32 POINT SERIES 1
PER FONT 52 PIECES \$5 00

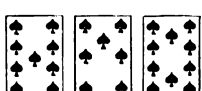
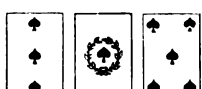
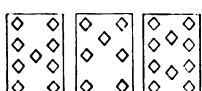
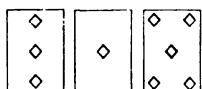
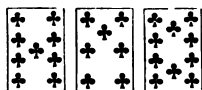
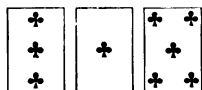
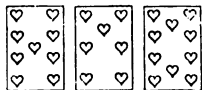
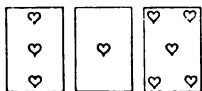

CARD INDICATORS

24 FT PER FONT \$1 75



10 FT PER LB \$1 30

12 FT PER LB \$1 16



Cast to order on 10 Point or 12 Point body

6 POINT PER FONT \$5 50

Complete with Rules, Leads and Spaces

3 ♠	A ♠	4 ♠	♣ 4
6 ♦	J ♦	K ♦	A ♦
7 ♦	9 ♦	2 ♦	Q ♦
♥ 9	♥ 10	5 ♦	10 ♦
♣ 2	♣ A	♣ 3	♣ 7
♥ 2	♥ J	♥ 6	♥ K
♥ 3	♥ 6	♥ A	♥ 4
2 ♠	♣ 5	K ♠	♥ 5
5 ♠	♣ 6	7 ♠	B ♦
6 ♠	♣ 9	8 ♠	4 ♦
9 ♠	10 ♣	10 ♠	3 ♦
♥ 7	♥ K	J ♠	♣ 8
♥ 7	♥ 8	Q ♠	♥ J



No. 82½. 15 cts.



No. 83½. 15 cts.



No. 84½. 15 cts.



No. 85½. 15 cts.

SET OF FOUR 40 CENTS

ARROWS

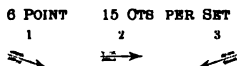

6 POINT

15 OTS PER SET

WHIST MARKERS

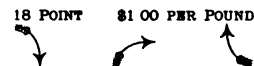

18 POINT

\$1 00 PER POUND

RECIPE MARKS

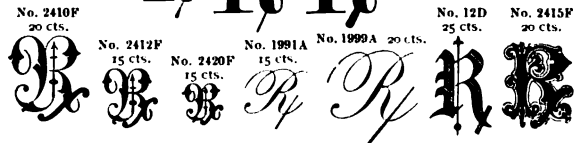

LOCUS SIGILLI



ELECTION SIGNS

For the various States using the Australian ballot. Additional signs will be made from time to time to conform with the changes in the election laws of the different States. If recent changes have been made in the election laws of your State, send for specimen sheet which will contain all new signs and emblems.

ILLINOIS AND IOWA

20 POINT ANTIQUE BX. OOND. No. 150 10 A \$2 00

12 POINT ROMAN No. 64

INDEPENDENT TICKET.

JOHN J. BROWNING.

No. 4 (Circle)
 No. 1 (X)
 No. 2 (Square)
 No. 3 (X in Square)
 No. 5 (X in Circle)
 KENTUCKY AND MICHIGAN
 No. 2 (Square), No. 6 (Square), No. 7 (Square), No. 8 (Square)
 OHIO
 No. 14 (Large Circle with text: FOR A STRAIGHT TICKET MARK WITHIN THIS CIRCLE)
 INDIANA
 No. 10 (DEM in Square), No. 9 (Square), No. 11 (REP in Square)
 WISCONSIN
 No. 9 (Square), No. 8 (Square)
 No. 12 (PROHI in Square), No. 13 (PEOP in Square)

No.	Body	Each	50 or more Each	100 or more Each
1-12	Point	\$0 05	\$0 04	\$0 03
2-20	"	06	04	03
3-20	"	06	04	03
4-40	"	15	12	10
5-40	"	15	12	10
6-12	"	06	04	03
7-10	"	06	04	03

No.	Body	Each	50 or more Each	100 or more Each
8-8	Point	\$0 06	\$0 04	\$0 03
9-30	"	06	04	04
10-30	"	06	04	04
11-30	"	06	04	04
12-30	"	06	04	04
13-30	"	06	04	04
14-72	"	25	—	—

COPPER ALLOY IMPRINTS

Cast in one piece, any of the faces here shown, at the following prices:

*100 OF ANY ONE KIND FOR \$8 00 NET. 50 OF ANY ONE KIND FOR \$5 00 NET.

*If Imprints are wanted longer than 1/4 inches in length, they will have to be made in two or more pieces, and \$3.00 per hundred will be charged for each extra piece.

<p>STYLE 1 COMMERCIAL PRINTING CO., ST. LOUIS.</p> <p>STYLE 2 R. P. STUDLEY & CO., PRINTERS, ST. LOUIS</p> <p>STYLE 3 THE MAYNARD BOUGH CO., PRINTERS, WORCESTER.</p> <p>STYLE 4 TRIBUNE JOB PRINTING CO.</p> <p>GEO. D. BARNARD & CO., PRINTERS, LITHOGRAPHERS [COPYRIGHTED]</p> <p>WM. P. BENNETT, PRINT. PITTSBURGH.</p> <p>INTELLIGENCER PRINT, WHEELING.</p>	<p>STYLE 5 WOODWARD & TIERNAN PRINTING CO.</p> <p>STYLE 6 BANNER PTG. CO.</p> <p>STYLE 7 LITTLE & BECKER, PRINT.</p> <p>STYLE 8 NIXON-JONES.</p> <p>PRESS OF STYLES & CASH, NEW YORK. THE EICHBAUM PRESS, PITTSBURGH.</p>
--	--

FIVE-POINTED STARS

Nos. 201F to 215F put up in fonts containing four of each No., \$1.00

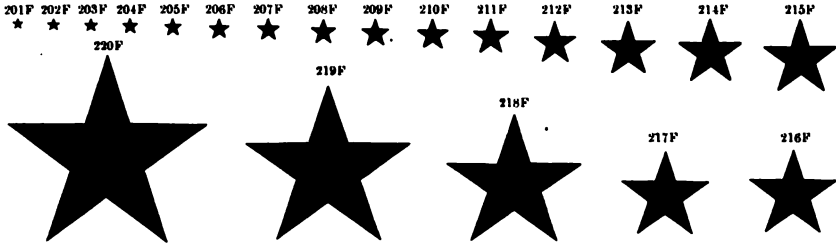

Nos. 201F to 210F, 15c. per set of four; Nos. 211F and 212F, 20c. per set of four; Nos. 213F to 215 F, 30c. per set of four; Nos. 216F and 217F, 15c. each; Nos. 218F and 210F, 20c. each; No. 220F, 25c. each.

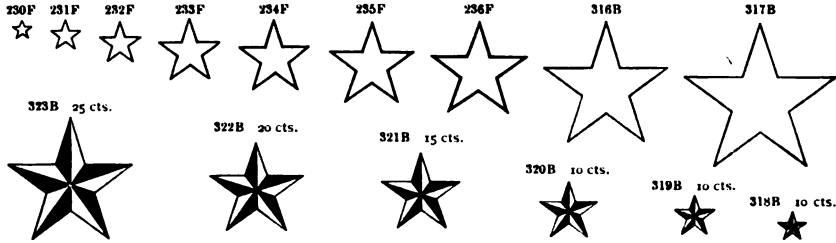

Nos. 230F to 232F, 20c. per set of four of any size; Nos. 233F to 235F, 10c. each; Nos. 236F and 316B, 15c. each; No. 317B, 20c. each.

MALTESE CROSSES

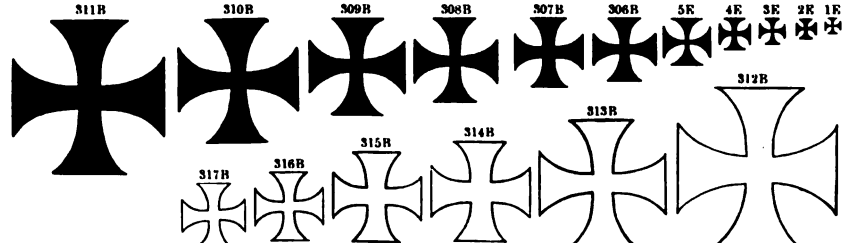

Nos. 1E to 4E, 15c. per set of four each; Nos. 5E, 306B, 307B, 316B, 317B, 10c. each; Nos. 308B, 309B, 314B, 315B, 15c. each; Nos. 310B, 313B, 20c. each; Nos. 311B, 312B, 25c. each.

SIX POINT STARS

3-pound fonts, containing both light and dark stars, with spaces and quads, \$3.25



BEARERS

Cast to order in fonts of not less than 25 lbs. of one size at Roman prices

12 POINT		PER LB \$0 66
11 POINT		PER LB \$0 70
10 POINT		PER LB \$0 74
9 POINT		PER LB \$0 80
8 POINT		PER LB \$0 80
7 POINT		PER LB \$1 00
6 POINT		PER LB \$1 16

DE VINNE FRACTIONS

Each font has same assortment as shown in 10 Point specimen

24 POINT PER FONT 50 CTS

$\frac{1}{4}$ $\frac{1}{2}$ $\frac{3}{4}$ $\frac{1}{3}$ $\frac{2}{3}$

14 POINT PER FONT 50 CTS

$\frac{1}{4}$ $\frac{1}{2}$ $\frac{3}{4}$ $\frac{1}{3}$ $\frac{2}{3}$ $\frac{1}{8}$ $\frac{3}{8}$

10 POINT PER FONT 50 CTS

$\frac{1}{4}$ $\frac{1}{2}$ $\frac{3}{4}$ $\frac{1}{3}$ $\frac{2}{3}$ $\frac{1}{8}$ $\frac{3}{8}$ $\frac{5}{8}$ $\frac{7}{8}$ $\frac{1}{6}$ $\frac{5}{6}$

7 POINT PER FONT 50 CTS

$\frac{1}{4}$ $\frac{1}{2}$ $\frac{3}{4}$ $\frac{1}{3}$ $\frac{2}{3}$ $\frac{1}{8}$ $\frac{3}{8}$ $\frac{5}{8}$ $\frac{7}{8}$ $\frac{1}{6}$ $\frac{5}{6}$

18 POINT PER FONT 50 CTS

$\frac{1}{4}$ $\frac{1}{8}$ $\frac{3}{8}$ $\frac{5}{8}$ $\frac{7}{8}$

12 POINT PER FONT 50 CTS

$\frac{1}{3}$ $\frac{2}{3}$ $\frac{1}{8}$ $\frac{3}{8}$ $\frac{5}{8}$ $\frac{7}{8}$ $\frac{1}{6}$ $\frac{5}{6}$

8 POINT PER FONT 50 CTS

$\frac{1}{4}$ $\frac{1}{2}$ $\frac{3}{4}$ $\frac{1}{3}$ $\frac{2}{3}$ $\frac{1}{8}$ $\frac{3}{8}$ $\frac{5}{8}$ $\frac{7}{8}$ $\frac{1}{6}$ $\frac{5}{6}$

6 POINT PER FONT 50 CTS

$\frac{1}{4}$ $\frac{1}{2}$ $\frac{3}{4}$ $\frac{1}{3}$ $\frac{2}{3}$ $\frac{1}{8}$ $\frac{3}{8}$ $\frac{5}{8}$ $\frac{7}{8}$ $\frac{1}{6}$ $\frac{5}{6}$

DE VINNE CONDENSED FRACTIONS

36 POINT PER FONT 75 CTS

$\frac{1}{4}$ $\frac{1}{2}$ $\frac{3}{4}$ $\frac{1}{3}$ $\frac{2}{3}$

30 POINT PER FONT 75 CTS

$\frac{1}{4}$ $\frac{1}{2}$ $\frac{3}{4}$ $\frac{1}{3}$ $\frac{2}{3}$ $\frac{1}{8}$ $\frac{3}{8}$ $\frac{5}{8}$ $\frac{7}{8}$

24 POINT PER FONT 50 CTS

$\frac{1}{4}$ $\frac{1}{2}$ $\frac{3}{4}$ $\frac{1}{3}$ $\frac{2}{3}$ $\frac{1}{8}$ $\frac{3}{8}$ $\frac{5}{8}$ $\frac{7}{8}$

18 POINT PER FONT 50 CTS

$\frac{1}{4}$ $\frac{1}{2}$ $\frac{3}{4}$ $\frac{1}{3}$ $\frac{2}{3}$ $\frac{1}{8}$ $\frac{3}{8}$ $\frac{5}{8}$ $\frac{7}{8}$

14 POINT PER FONT 50 CTS

$\frac{1}{4}$ $\frac{1}{2}$ $\frac{3}{4}$ $\frac{1}{3}$ $\frac{2}{3}$ $\frac{1}{8}$ $\frac{3}{8}$ $\frac{5}{8}$ $\frac{7}{8}$

12 POINT PER FONT 50 CTS

$\frac{1}{4}$ $\frac{1}{2}$ $\frac{3}{4}$ $\frac{1}{3}$ $\frac{2}{3}$ $\frac{1}{8}$ $\frac{3}{8}$ $\frac{5}{8}$ $\frac{7}{8}$

10 POINT PER FONT 50 CTS

† † † † † † † † †

8 POINT PER FONT 50 CTS

† † † † † † † † †

6 POINT PER FONT 50 CTS

† † † † † † † † †

QUENTELL FRACTIONS

36 POINT PER FONT 75 CTS

$\frac{1}{4}$ $\frac{1}{2}$ $\frac{3}{4}$ $\frac{1}{3}$ $\frac{2}{3}$

30 POINT PER FONT 75 CTS

$\frac{2}{3}$ $\frac{1}{8}$ $\frac{3}{8}$ $\frac{5}{8}$ $\frac{7}{8}$

24 POINT PER FONT 50 CTS

$\frac{1}{4}$ $\frac{1}{2}$ $\frac{3}{4}$ $\frac{1}{3}$ $\frac{2}{3}$ $\frac{1}{8}$ $\frac{3}{8}$

18 POINT PER FONT 50 CTS

$\frac{1}{4}$ $\frac{1}{2}$ $\frac{3}{4}$ $\frac{1}{3}$ $\frac{2}{3}$ $\frac{1}{8}$ $\frac{3}{8}$ $\frac{5}{8}$ $\frac{7}{8}$

14 POINT PER FONT 50 CTS

$\frac{1}{4}$ $\frac{1}{2}$ $\frac{3}{4}$ $\frac{1}{3}$ $\frac{2}{3}$ $\frac{1}{8}$ $\frac{3}{8}$ $\frac{5}{8}$ $\frac{7}{8}$

12 POINT PER FONT 50 CTS

$\frac{1}{4}$ $\frac{1}{2}$ $\frac{3}{4}$ $\frac{1}{3}$ $\frac{2}{3}$ $\frac{1}{8}$ $\frac{3}{8}$ $\frac{5}{8}$ $\frac{7}{8}$

10 POINT PER FONT 50 CTS

$\frac{1}{4}$ $\frac{1}{2}$ $\frac{3}{4}$ $\frac{1}{3}$ $\frac{2}{3}$ $\frac{1}{8}$ $\frac{3}{8}$ $\frac{5}{8}$ $\frac{7}{8}$

8 POINT PER FONT 50 CTS

$\frac{1}{4}$ $\frac{1}{2}$ $\frac{3}{4}$ $\frac{1}{3}$ $\frac{2}{3}$ $\frac{1}{8}$ $\frac{3}{8}$ $\frac{5}{8}$ $\frac{7}{8}$

6 POINT PER FONT 50 CTS

$\frac{1}{4}$ $\frac{1}{2}$ $\frac{3}{4}$ $\frac{1}{3}$ $\frac{2}{3}$ $\frac{1}{8}$ $\frac{3}{8}$ $\frac{5}{8}$ $\frac{7}{8}$

For Body Type Fractions see pages 44 and 45

DORIC FRACTIONS

42 POINT 1 LB FONT 54 OTS
 $\frac{1}{4}$ $\frac{1}{2}$ $\frac{3}{4}$

36 POINT 1 LB FONT 56 OTS
 $\frac{1}{4}$ $\frac{1}{2}$ $\frac{3}{4}$

30 POINT 1 LB FONT 56 OTS
 $\frac{1}{4}$ $\frac{1}{2}$ $\frac{3}{4}$

24 POINT 1 LB FONT 56 OTS
 $\frac{1}{4}$ $\frac{1}{2}$ $\frac{3}{4}$

GOTHIC FRACTIONS

Each font has same assortment as shown in 6 Point specimen

18 POINT 1 LB FONT 60 OTS
 $\frac{1}{4}$ $\frac{1}{2}$ $\frac{3}{4}$ $\frac{1}{3}$ $\frac{2}{3}$

12 POINT 1 LB FONT 66 OTS
 $\frac{3}{4}$ $\frac{1}{3}$ $\frac{2}{3}$ $\frac{1}{8}$ $\frac{3}{8}$ $\frac{5}{8}$

6 POINT 1 LB FONT 81 16
 $\frac{1}{4}$ $\frac{1}{2}$ $\frac{3}{4}$ $\frac{1}{8}$ $\frac{3}{8}$ $\frac{5}{8}$ $\frac{7}{8}$

ANTIQUÉ FRACTIONS

All sizes are complete as here shown

36 POINT No 20 PER FONT \$1 00 28 POINT No 20 PER FONT \$1 00
 $\frac{1}{4}$ $\frac{1}{2}$ $\frac{3}{4}$ $\frac{1}{4}$ $\frac{1}{2}$ $\frac{3}{4}$

18 POINT No 20 PER FONT \$1 00
 $\frac{1}{4}$ $\frac{1}{2}$ $\frac{3}{4}$ $\frac{1}{8}$ $\frac{3}{8}$ $\frac{5}{8}$ $\frac{7}{8}$

12 POINT No 22 PER FONT \$1 00
 $\frac{1}{4}$ $\frac{1}{2}$ $\frac{3}{4}$ $\frac{1}{8}$ $\frac{3}{8}$ $\frac{5}{8}$ $\frac{7}{8}$

18 POINT No 22 PER FONT \$1 00 14 POINT No 22 PER FONT \$1 00
 $\frac{1}{4}$ $\frac{1}{2}$ $\frac{3}{4}$ $\frac{1}{4}$ $\frac{1}{2}$ $\frac{3}{4}$

POSTER ROMAN No 120 FRACTIONS

48 POINT 1 LB FONT 54 OTS
 $\frac{1}{4}$ $\frac{1}{2}$ $\frac{3}{4}$

30 POINT 1 LB FONT 56 OTS
 $\frac{1}{4}$ $\frac{1}{2}$ $\frac{3}{4}$

24 POINT 1 LB FONT 56 OTS
 $\frac{1}{4}$ $\frac{1}{2}$ $\frac{3}{4}$ $\frac{1}{3}$ $\frac{2}{3}$

POSTER ROMAN No 123 FRACTIONS

30 POINT 1 LB FONT 56 OTS
 $\frac{1}{2}$ $\frac{3}{4}$ $\frac{1}{3}$ $\frac{2}{3}$

24 POINT 1 LB FONT 60 OTS
 $\frac{1}{4}$ $\frac{1}{2}$ $\frac{3}{4}$ $\frac{1}{3}$ $\frac{2}{3}$

18 POINT 1 LB FONT 60 OTS
 $\frac{1}{4}$ $\frac{1}{2}$ $\frac{3}{4}$ $\frac{1}{3}$ $\frac{2}{3}$

12 POINT 1 LB FONT 66 OTS
 $\frac{1}{4}$ $\frac{1}{2}$ $\frac{3}{4}$

GOTHIC COND. FRACTIONS

36 POINT 1 LB FONT 54 OTS
 $\frac{1}{4}$ $\frac{1}{2}$ $\frac{3}{4}$ $\frac{1}{3}$ $\frac{2}{3}$

$\frac{1}{8}$ $\frac{3}{8}$ $\frac{5}{8}$ $\frac{7}{8}$

24 POINT 1 LB FONT 56 OTS
 $\frac{1}{4}$ $\frac{1}{2}$ $\frac{3}{4}$ $\frac{1}{3}$ $\frac{2}{3}$ $\frac{1}{8}$

$\frac{3}{8}$ $\frac{5}{8}$ $\frac{7}{8}$

18 POINT 1 LB FONT 60 OTS
 $\frac{1}{4}$ $\frac{1}{2}$ $\frac{3}{4}$ $\frac{1}{3}$ $\frac{2}{3}$ $\frac{1}{8}$ $\frac{3}{8}$ $\frac{5}{8}$ $\frac{7}{8}$

12 POINT 1 LB FONT 66 OTS
 $\frac{1}{4}$ $\frac{1}{2}$ $\frac{3}{4}$ $\frac{1}{3}$ $\frac{2}{3}$ $\frac{1}{8}$ $\frac{3}{8}$ $\frac{5}{8}$ $\frac{7}{8}$

CALEDONIAN FRACTIONS

18 POINT 1 LB FONT 60 OTS
 $\frac{1}{4}$ $\frac{1}{2}$ $\frac{3}{4}$ $\frac{2}{3}$

JOB COMMERCIAL SIGNS

Each size is complete as here shown

36 POINT PER FONT 50 OTS
 1 2 3
 @ % lb

30 POINT PER FONT 50 OTS
 1 2 3
 @ % lb

18 POINT PER FONT 50 OTS
 1 2 4 8 3
 @ % lb c P

12 POINT PER FONT 50 OTS
 1 6 16 2
 @ % lb c P

CALENDAR FIGURES

Put up in fonts sufficient to set one month, with enough extra figures and sorts to complete each of the twelve months. Order by name and No.

No 1806 \$1 00

45

No 6001

\$5 50

78

No 6005

\$4 50

26

No 1802 \$0 75

937

No 2406 \$1 30

45

No 2402 \$1 00

937

No 5401

\$4 70

78

No 5405

\$5 00

26

No 3002 \$1 35

937

No 3006 \$1 95

45

No 3806 \$2 80

45

No 4801

\$3 65

78

No 4805

\$3 90

26

No 3602 \$1 90

937

No 4206 \$3 50

45

No 4201

\$3 15

78

No 4205

\$3 30

26

No 4202 \$2 40

937

No 4806 \$4 00

45

No 3601 \$2 30

78

No 3805

\$2 50

26

No 4802 \$3 00

937

No 5406 \$5 20

45

No 3001 \$1 90

78

No 3005

\$1 95

26

No 5402 \$3 80

937

No 6006 \$5 90

45

No 2401 \$1 25

78

No 2405

\$1 30

26

No 6002 \$4 45

937

No 1801 \$1 00

78

No 1805

\$1 00

26

CALENDAR FIGURES

Put up in fonts sufficient to set one month, with enough extra figures and sorts to complete each of the twelve months. Order by name and No.

No 1807 \$0 75

239

No 6008

\$5 25

45

No 6011

\$5 75

73

No 1810 \$1 00

168

No 2407 \$1 00

239

No 2410 \$1 25

168

No 5408

\$4 65

45

No 5411

\$4 80

73

No 3010 \$1 75

168

No 3007 \$1 45

239

No 3610 \$2 20

168

No 3607 \$1 90

239

No 4208 \$3 10

45

No 3611 \$2 80

73

No 4210 \$3 00

168

No 4207 \$2 25

239

No 3608 \$2 15

45

No 3011 \$2 15

73

No 4810 \$3 75

168

No 5407

\$3 60

239

No 3008 \$1 65

45

No 2411 \$1 35

73

No 5410 \$4 65

168

No 2408 \$1 40

45

No 1811 \$1 00

73

No 6010 \$5 25

168

No 6007

\$4 00

239

No 2008 \$1 25

45

No 1812 \$1 00

34

**PERPETUAL
CALENDAR
LOGOTYPES**

No. 4.—\$2.50 per set, including fifty-two logotypes, rules and fonts for month and year; can be used for any month in any year; change made in three minutes.

No. 1.—\$4.00 per set, including fifty-two logotypes, rules and fonts for month and year; can be used for any month in any year; change made in three minutes.

Th APRIL 31

19 20 F

1899 SEPTEMBER 1899						
Su	Mo	Tu	We	Th	Fr	Sa
					1	2
3	4	5	6	7	8	9
10	11	12	13	14	15	16
17	18	19	20	21	22	23
24	25	26	27	28	29	30
	<i>Perpetual Calendar, No. 4</i>					

1899		JUNE					1899	
SUN	MON	TUE	WED	THU	FRI	SAT		
				1	2	3		
4	5	6	7	8	9	10		
11	12	13	14	15	16	17		
18	19	20	21	22	23	24		
25	26	27	28	29	30			
		<i>Perpetual Calendar, No. 1</i>						

**PERPETUAL
CALENDAR
LOGOTYPES**

No. 3.—\$3.00 per set, including fifty-two logotypes, rules and fonts for month and year; can be used for any month in any year; can be changed in three minutes.

No. 2.—\$3.50 per set, including fifty-two logotypes, rules and fonts for month and year; can be used for any month in any year; can be changed in three minutes.

1899		MARCH					1899	
SUN	MON	TUE	WED	THU	FRI	SAT		
			1	2	3	4		
5	6	7	8	9	10	11		
12	13	14	15	16	17	18		
19	20	21	22	23	24	25		
26	27	28	29	30	31			
<i>Perpetual Calendar, No. 3</i>								

1899		AUGUST					1899	
Su	Mo	Tu	We	Th	Fr	Sa		
		1	2	3	4	5		
6	7	8	9	10	11	12		
13	14	15	16	17	18	19		
20	21	22	23	24	25	26		
27	28	29	30	31				
<i>Perpetual Calendar, No. 2</i>								

14

1899

SAT

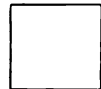

U S

26

SECTIONAL CALENDARS

189 Sun 1 8 15 22	1898	JULY					1898
	Sun	Mon	Tue	Wed	Thu	Fri	Sat
	--	--	--	--	--	1	2
	3	4	5	6	7	8	9
	10	11	12	13	14	15	16
	17	18	19	20	21	22	23
	24	25	26	27	28	29	30
31	--	--	--	<i>Sectional Calendar No. 6. — \$3.00</i>			

1898	JUNE					1898
Sun	Mon	Tue	Wed	Thu	Fri	Sat
			1	2	3	4
5	6	7	8	9	10	11
12	13	14	15	16	17	18
19	20	21	22	23	24	25
26	27	28	29	30		
<i>Sectional Calendar, No. 5. — \$2.50</i>						

<i>Sectional Calendar No. 8. — \$4.00</i>		

	98	16
Wed	MARCH	

Rules and Figures for One Month, with Changes for Ten Years

INDEX CUTS

No. 4015F. 20 cts.



No. 4016F. 20 cts.



No. 1522D. 50 cts.



No. 1521D. 50 cts.



No. 1072E. 12 cts.



No. 1073E. 12 cts.



No. 3846B. 30 cts.



No. 3852B. 25 cts.



No. 3847B. 30 cts.



No. 4018F. 25 cts.



No. 3853B. 25 cts.



No. 4017F. 25 cts.



No. 1406D. 60 cts.

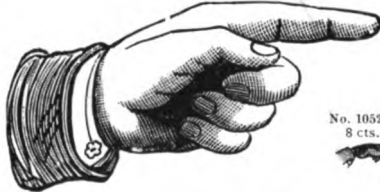

No. 1052E. 8 cts.



No. 1053E. 8 cts.



No. 1407D. 60 cts.



No. 1074E. 20 cts.



No. 1075E. 20 cts.



No. 1078E. 30 cts.



No. 1070E. 15 cts.



No. 1071E. 15 cts.



No. 1079E. 30 cts.



No. 4018F. 15 cts.



No. 4012F. 10 cts.



No. 4009F. 10 cts.



No. 4007F. 10 cts.



No. 4005F. 5 cts.



No. 4006F. 5 cts.



No. 4008F. 10 cts.



No. 4010F. 10 cts.



No. 4011F. 10 cts.



No. 4014F. 15 cts.



No. 4001F. 5 cts.



No. 4008F. 5 cts.



No. 4004F. 5 cts.



No. 4002F. 5 cts.



COMMERCIAL LOGOTYPES

No. 501C. 10 cts. <i>189</i>	No. 502C. 10 cts. <i>189</i>	No. 508C. 10 cts. <i>189</i>	No. 504C. 10 cts. <i>189</i>	No. 506C. 10 cts. <i>Dⁿ</i>	No. 516C. 10 cts. <i>Cⁿ</i>
No. 2405F. 15 cts. <i>M</i>	No. 512C. 10 cts. <i>M</i>	No. 513C. 10 cts. <i>M</i>	No. 514C. 10 cts. <i>No.</i>	No. 515C. 10 cts. <i>No.</i>	No. 511C. 10 cts. <i>M</i>
No. 546C. 15 cts. <i>M</i>	No. 547C. 15 cts. <i>M</i>	No. 548C. 15 cts. <i>No.</i>	No. 549C. 15 cts. <i>No.</i>	No. 566C. 30 cts. <i>Received</i>	
No. 544C. 15 cts. <i>Dⁿ</i>	No. 3997F. 20 cts. <i>So.</i>	No. 3998F. 20 cts. <i>Di.</i>	No. 3999F. 20 cts. <i>Cr.</i>	No. 4139F. 15 cts. <i>M</i>	
<i>Lincoln Dollars and charge to account of</i>					
<i>Bought of Dollars St. Louis</i>					
<small>Solid body Electros, set in 28 Point Spencerian Script No. 2, as in line above, furnished at 25 cents per lineal inch</small>					
<small>Solid body Electros, set in 40 Point Spencerian Script No. 2, as in line above, furnished at 30 cents per lineal inch</small>					

BILLHEAD LOGOTYPES

No. 106C. 40 cts. 	No. 107C. 40 cts. 	No. 103C. 40 cts.
No. 108C. 40 cts. 	No. 97C. 40 cts. 	No. 94C. 40 cts.
No. 105C. 40 cts. 	No. 93C. 35 cts. 	No. 92C. 30 cts.
No. 104C. 40 cts. 	No. 99C. 35 cts. 	No. 95C. 40 cts.

CHECK BLANKS

In ordering be careful to add the words "Check Blank" to the No. wanted

No. 317C. 75 cts.



No. 329C. 40 cts.



No. 327½C. 75 cts.



No. 323C. 75 cts.



No. 321C. 40 cts.



No. 323½C. 75 cts.



No. 320C. 50 cts.

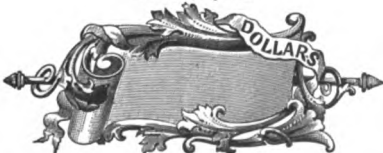

No. 328C. 75 cts.



No. 330C. 30 cts.



No. 328½C. 75 cts.

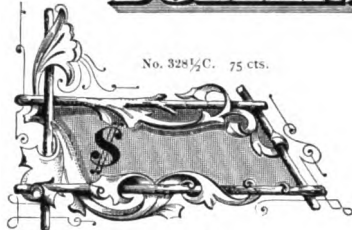

No. 326C. 75 cts.



No. 322C. 40 cts.



No. 326¼C. 75 cts.

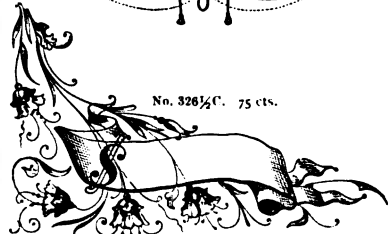

No. 319C. 50 cts.



ELECTROTYPED DATE LINES

PRICE, 75 CENTS EACH, FOR ANY CITY, AS PER STYLES BELOW

STYLE NO 1F	<i>Dallas, Tex.,</i>	189	STYLE NO 8F	<i>Boise City, Idaho,</i>	189
STYLE NO 2F	<i>Topeka, Kans.,</i>	189	STYLE NO 15F	<i>Lincoln, Neb.,</i>	189
STYLE NO 3F	<i>Denver, Colo.,</i>	189	STYLE NO 16F	<i>St. Louis, Mo.,</i>	189
STYLE NO 6F	<i>Detroit,</i>	189	STYLE NO 17F	<i>Minneapolis, Minn.,</i>	189
STYLE NO 7F	<i>Chester, Tex.,</i>	189	STYLE NO 18F	<i>Salem, Ore.,</i>	189
STYLE NO 9F	<i>Omaha, Neb.,</i>	189	STYLE NO 20F	<i>Boise City, Idaho,</i>	189
STYLE NO 11F	<i>Portland, Ore.,</i>	189	STYLE NO 60 1/2 F	<i>Hartford, Ind.,</i>	189
STYLE NO 12F	<i>Sacramento, Cal.,</i>	189	STYLE NO 21F	<i>Louisville, Ky.,</i>	189
			STYLE NO 22F	<i>Garthage, Mo.,</i>	189

NEWSPAPER SUB-HEADINGS

Order by name, No and initial

TRIMMED TO 13 EMS PICA

PRICE 50 CENTS EACH

NO 26E
DENVER RECORD.

NO 23E
MORNING WORLD.

NO 27E
DAILY TRUTH.

NO 21E
RACINE REPUBLICAN.

NO 22E
MORNING JOURNAL.

NO 28½E
BICYCLE REVIEW.

NO 9F
DAILY TRANSCRIPT.

NO 7F
THE LEADER.

NO 30E
OXFORD REPORTER.

NO 41E
THE JEFFERSON HAWKEYE.

NO 13F
ARBEITER ZEITUNG NEWS.

NO 10F
THE MINING JOURNAL.

NO 3F
THE REPUBLICAN.

NO 5F
DAILY REPUBLICAN.

NO 1F
DAILY RECORD.

NO 3E
The Chicago Bulletin.

NO 33E
Evening Recorder.

NO 32E
The Illinois Independent.

NO 14E
The Weekly Reporter.

NO 16E
Iowa Friday Globe.

NO 18E
Evening Graphic.

NO 53E
The Duluth Signal.

NO 54E
Boston Review.

NO 2F
The Morning Journal.

NO 32½E
The Daily Argus.

NO 38E
Dakota Signal.

NO 34E
New York Eagle.

NO 35E
The Advance.

NEWSPAPER HEADINGS

Price List for Headings on bodies the full width of page. Any heading made from type can be matched

WIDTH OF HEADING	BODY-- PICA MEASUREMENT						
	4-LINE	5-LINE	6-LINE	7-LINE	8-LINE	9-LINE	10-LINE
4 Column	\$2 00	\$2 25	\$2 50	\$2 75	\$3 00	\$3 25	\$3 50
5 "	2 25	2 50	2 75	3 00	3 25	3 50	3 75
6 "	2 50	2 75	3 00	3 25	3 50	3 75	4 00
7 "	2 75	3 00	3 25	3 50	3 75	4 00	4 25
8 "	3 00	3 25	3 50	3 75	4 00	4 25	4 50
9 "	3 25	3 50	3 75	4 00	4 25	4 50	4 75

STYLE NO 100 ¹²

FOUR-LINE PICA

Buffalo Tribune

STYLE NO 102 ¹²

FIVE-LINE PICA

GRETNA POST

STYLE NO 105 ^{0 12 15}

FOUR-LINE PICA

TRIBUNE

STYLE NO 108 ^{0 12}

SIX-LINE PICA

BLADE

STYLE NO 107 ⁰

SIX-LINE PICA

ACMIE

NEWSPAPER HEADINGS

For prices, see page 580

STYLE NO 120 ⁰⁻¹²

FIVE-LINE PICA

Belton Post

STYLE NO 36 ⁰⁻¹²

FIVE-LINE PICA

COURIER

STYLE NO 122 ⁰⁻¹²

SIX-LINE PICA

New Idea

STYLE NO 123 ⁰⁻¹²

SIX-LINE PICA

TRUTH

STYLE NO 44 ¹⁶

SIX-LINE PICA

Christian

STYLE NO 118 ¹⁶

SIX-LINE PICA

HERALD

NEWSPAPER HEADINGS

For prices, see page 580

STYLE NO 127 " "

SIX-LINE PICA

TRIBUNE

STYLE NO 129 " "

SIX-LINE PICA

Recorder

STYLE NO 130 " "

SIX-LINE PICA

CIRCUIT

STYLE NO 115 " "

FIVE-LINE PICA

MELBA SUN

STYLE NO 124 " "

SIX-LINE PICA

Farm Echo

STYLE NO 125 " "

SIX-LINE PICA

SENTINEL

NEWSPAPER HEADINGS

For prices, see page 580

STYLE No 112

FIVE-LINE PICA

CITIZEN

STYLE 113

FIVE-LINE PICA

Mechanic

STYLE 114

SIX-LINE PICA

COAL MINER

STYLE No 148

FOUR-LINE PICA

The Guardian

STYLE No 135

FIVE-LINE PICA

Raleigh Leader

STYLE No 137

SIX-LINE PICA

Advertiser

NEWSPAPER HEADINGS

For prices, see page 580

STYLE NO 138 0-15

FIVE-LINE PICA

Salem Item

STYLE NO 141 0-12

SEVEN-LINE PICA

Enterprise

STYLE NO 143 0-12

EIGHT-LINE PICA

The News

STYLE NO 147 4

FIVE LINE PICA

Volkswacht

STYLE NO 69 3

SEVEN LINE PICA

Neue Welt

CAST INITIALS

48 POINT MORTISED NO 2

3A \$6 00



SERIES NO 1136 PER SET \$2 00

SERIES NO 1132 PER SET \$3 50
SINGLE LETTER 40 CENTS



SERIES NO 441
SINGLE LETTER WITH PENDANTS 40 CENTS
PER SET WITH PENDANTS AND SPACES \$7 00

SERIES NO 440
SINGLE LETTER WITH PENDANTS 40 CENTS
PER SET WITH PENDANTS \$5 00



48 POINT ART INITIALS
PER SET WITH ORNAMENTS \$3 00

72 POINT ART INITIALS
PER SET WITH ORNAMENTS \$4 00



SERIES NO 1143 PER SET \$3 50

SERIES 1142 PER SET \$2 00



SERIES NO 1133
PER SET \$3 50 SINGLE LETTER 40 CENTS

SERIES 1155
PER SET \$3 50 SINGLE LETTER 40 CENTS

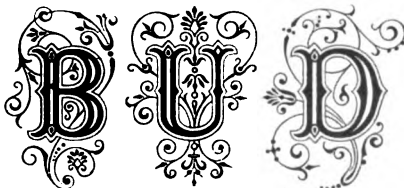

CAST INITIALS

SERIES No 52
PER SET \$7 00 SINGLE LETTER 60 CENTS



SERIES No 1148
PER SET \$3 50 SINGLE LETTER 30 CENTS

SERIES No 1147
PER SET \$2 25
SINGLE LETTER 25 CENTS



SERIES No 60
PER SET \$3 50
SINGLE LETTER 40 CTS



SERIES No 1146
PER SET \$1 75
SINGLE LETTER 20 CTS



SERIES No 51
PER SET \$4 50
SINGLE LETTER 50 CENTS



54 POINT BRADLEY INITIALS
3 A \$4 25
SINGLE LETTER 25 CENTS



42 POINT BRADLEY INITIALS
3 A \$3 00
SINGLE LETTER 20 CENTS



60 POINT TENDRIL INITIALS No 1
PER SET \$8 00
SINGLE LETTER 50 CENTS



30 POINT JENSON INITIALS No 82
SINGLE LETTER 25 CENTS



72 POINT JENSON INITIALS
No 79
SINGLE LETTER 60 CENTS



48 POINT JENSON INITIALS
No 80
SINGLE LETTER 50 CENTS



48 POINT SCHOEFFER OLD STYLE
INITIALS
3 A \$4 00



36 POINT SCHOEFFER OLD STYLE
INITIALS
4 A \$3 50



24 POINT SCHOEFFER OLD STYLE
INITIALS
6 A \$2 50



15 POINT SCHOEFFER OLD STYLE
INITIALS
8 A \$1 50



48 POINT TENDRIL INITIALS No 2
PER SET \$6 00
SINGLE LETTER 40 CENTS



CAST INITIALS

SERIES NO 321 ORNAMENTED
PER SET \$7 50 SINGLE LETTER 50 CENTS

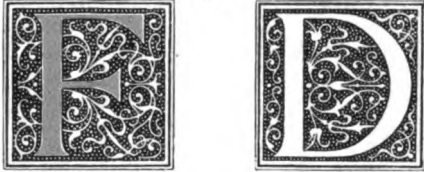

SERIES NO 321 PLAIN
PER SET \$6 00 SINGLE LETTER 50 CENTS



SERIES NO 320 PLAIN
PER SET \$3 50 SINGLE LETTER 35 CENTS



SERIES NO 320 ORNAMENTED
PER SET \$5 00 SINGLE LETTER 35 CENTS



36 POINT IPSSEN INITIALS No 2
PER SET \$4 00 SINGLE LETTER 30 CENTS



48 POINT IPSSEN INITIALS No 1
PER SET \$6 00 SINGLE LETTER 40 CENTS



72 POINT EMPIRE INITIALS
PER FONT \$4 00 SINGLE LETTER 25 CENTS



48 POINT EMPIRE INITIALS
PER FONT \$3 00 SINGLE LETTER 20 CENTS



ELECTROTYPED INITIALS

WAYSIDE INITIALS No 1
PER SET 51 LETTERS \$22 50 SINGLE LETTER 60 CTS.



WAYSIDE INITIALS No 2
PER SET 51 LETTERS \$22 50 SINGLE LETTER 60 CTS.



HAPGOOD INITIALS No 2
PER SET 26 LETTERS \$10 00 SINGLE LETTER 50 CTS.



HAPGOOD INITIALS No 1
PER SET 26 LETTERS \$10 00 SINGLE LETTER 50 CTS.



ELECTROTYPED INITIALS

SPHINX SERIES
PER SET \$20 00 SINGLE LETTER \$1 00



SERIES No 426
PER SET \$7 00
SINGLE LETTER 35 CENTS

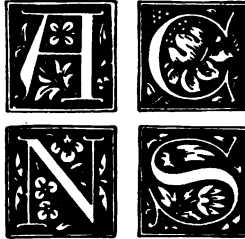

ACORN SERIES No 71
PER SET \$20 00
SINGLS LETTER \$1 00



SERIES No 425
PER SET \$6 00
SINGLE LETTER 30 CENTS

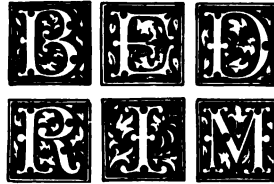

WAVERLEY SERIES No 74
SINGLE LETTER 60 CENTS

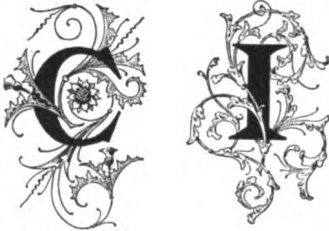

ACORN SERIES No 72
PER SET \$15 00 SINGLE LETTER 75 CENTS

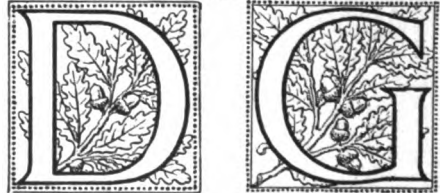

WAVERLEY SERIES No 75
SINGLE LETTER 75 CENTS



ACORN SERIES No 73
PER SET \$12 00 SINGLE LETTER 60 CENTS



SERIES No 421
PER SET \$7 00 SINGLE LETTER 35 CENTS



ELECTROTYPED INITIALS

MORRIS SERIES No 76

PER SET \$15 00 SINGLE LETTER 75 CENTS



MORRIS SERIES No 77

PER SET \$12 00 SINGLE LETTER 60 CENTS



SERIES No 1159
PER SET WITH ORNA-
MENTS \$4 50
SINGLE LETTER 40 CTS.
Each in three pieces



MORRIS SERIES No 78

PER SET \$10 00 SINGLE LETTER 50 CTS.



No 4140
40 CENTS



RENATE SERIES No 70
PER SET \$12 00
SINGLE LETTER 60 CENTS



RENATE SERIES No 69
PER SET \$15 00 SINGLE LETTER 75 CENTS



SERIES No 1158
PER SET \$8 00
SINGLE LETTER 50 CENTS



FIFTH INITIALS
PER SET \$10 00
SINGLE LETTER 50 CENTS



INDEX INITIALS
PER SET \$10 00 SINGLE LETTER 50 CTS.



INDEX INITIALS SECOND SERIES
PER SET \$8 00 SINGLE LETTER 40 CTS.



CONTOUR POINTERS ¹⁹

PER FONT \$1 25

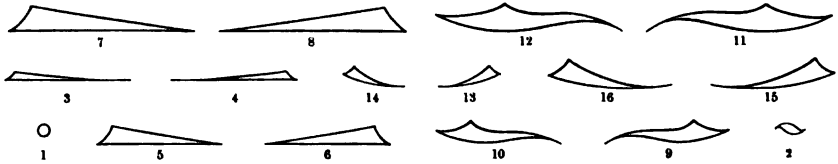

SHADED POINTERS ¹⁷

PER FONT \$1 25

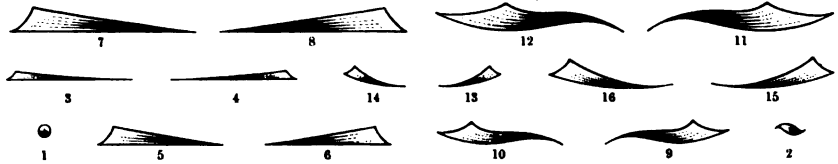

POINTERS ¹⁹

PER FONT \$1 25

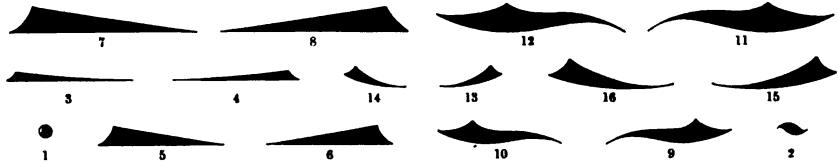

PIN, NAIL AND SCREW HEADS No 2

PER FONT \$3 00

Fonts contain twelve pieces of each character

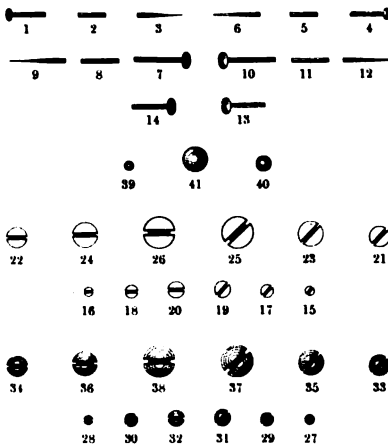

PIN, NAIL AND SCREW HEADS

PER FONT 75 CENTS

Fonts contain twelve of each character

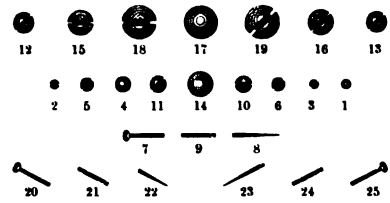

PRINTERS' NIC NACS ¹⁷

All on 6 Point body

PER FONT \$1 00

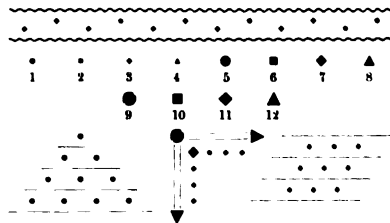

PALMETTO ORNAMENTS

PER FONT \$1 00



SHADED PALMETTO ORNAMENTS

PER FONT \$1 00



CONTOUR PALMETTO ORNAMENTS

PER FONT \$1 00

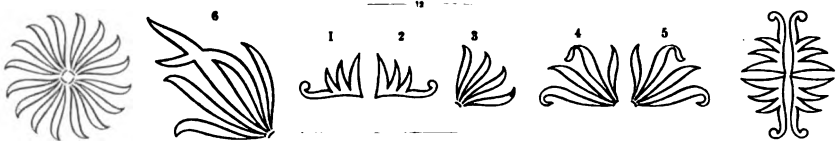

CENTRAL ORNAMENTS No 1

PER FONT \$1 00



CENTRAL ORNAMENTS No 2

PER FONT \$1 00



CENTRAL ORNAMENTS No 3

PER FONT \$1 00



TURNER ORNAMENTS

PER FONT \$2 00

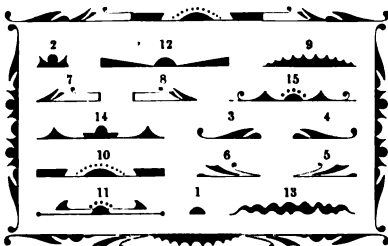

STELLAR ORNAMENTS

PER FONT \$1 25

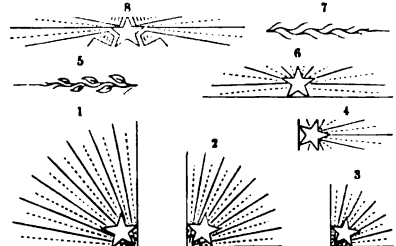

CENTRAL ORNAMENTS

SERIES No 4

PER FONT \$2 00

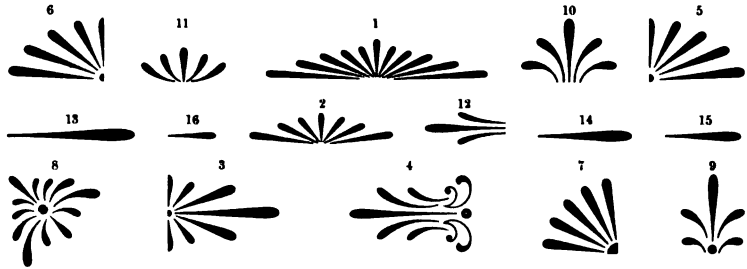

SERIES No 5

PER FONT \$2 00

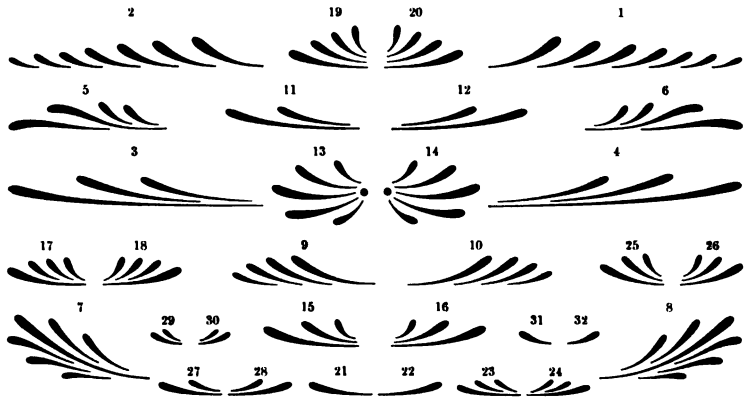

SERIES No 6

PER FONT \$2 00

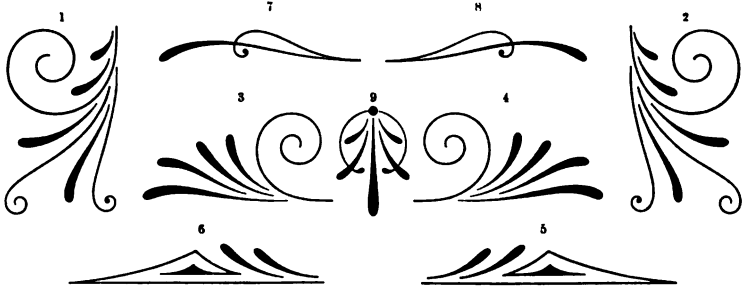

APPLE BLOSSOM ORNAMENTS

-12-

WHOLE FONT \$3 00
HALF FONT \$1 75

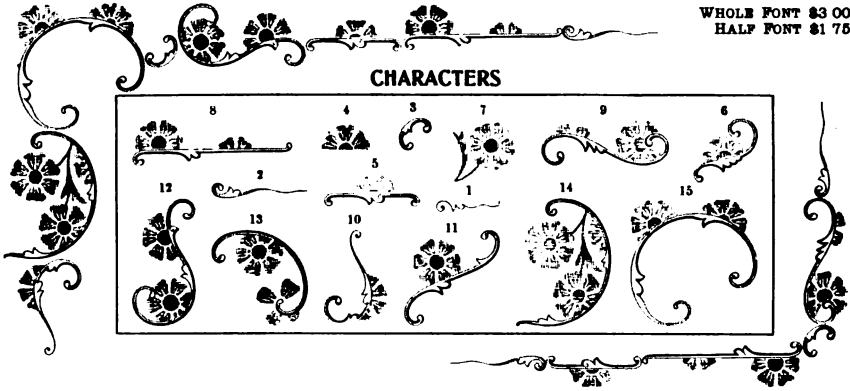

RULE ORNAMENTS

SERIES NO 1

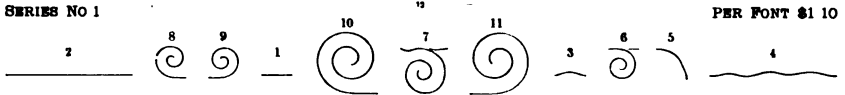

SERIES NO 2



SERIES NO 3

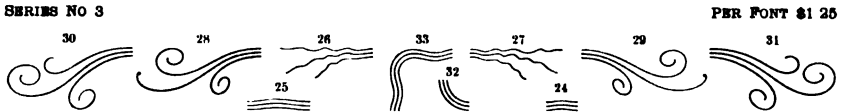

SERIES NO 4



SCROLL CORNER ORNAMENTS

-12-

PER FONT \$3 00

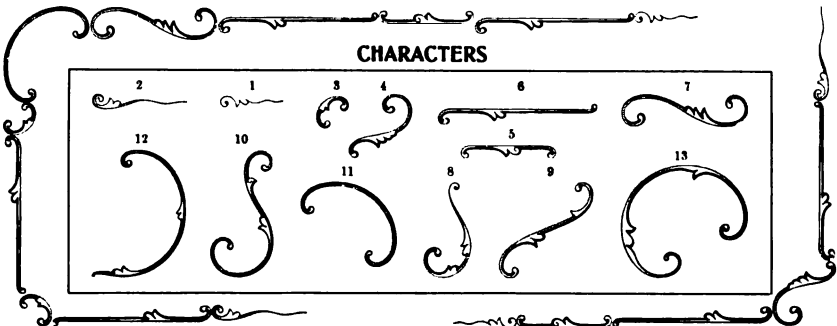

EGYPTIAN ORNAMENTS

THE simplicity of these Ornaments is at once apparent.
Artistic effects are quickly produced with the aid of
these Ornaments and two-point full-face Brass Rule

SERIES A PER FONT \$2 50
HALF FONT 1 25

3 4

1 2

7 8

9

6

5

SERIES B PER FONT \$2 50
HALF FONT 1 25

11 12

13

14

15

16 17

18

19 20

10

SERIES C PER FONT \$2 50
HALF FONT 1 25

22

23 24

25

26 27

21

MIDGET TAIL PIECES

PER FONT (containing three of each character) \$1 25

1

2

3

4

5

6

7

8

9

10

11

12

13

14

MANILA BORDER



There are seven characters, as above

DEWEY ORNAMENTS

SERIES ONE

FONT (one of each character) \$1 50

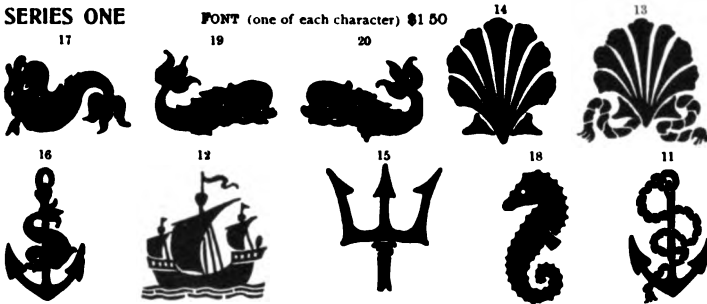

SERIES TWO

FONT (one of each character) \$2 00

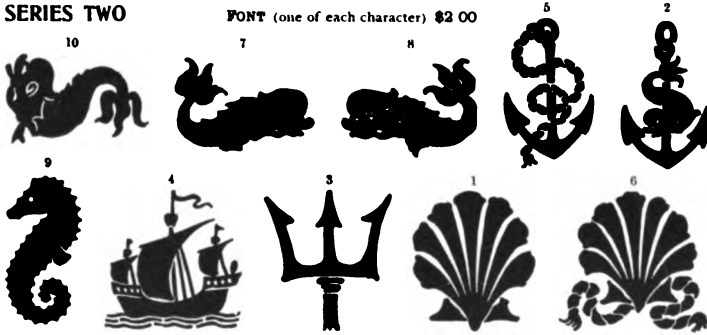

SERIES THREE

FONT (one of each character) \$1 00

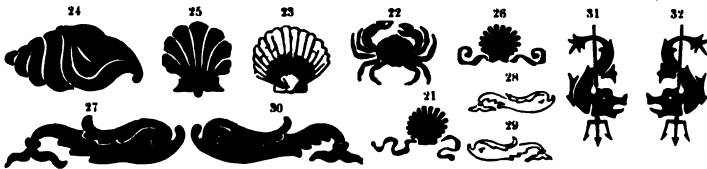

COLLINS FLORETS

GROUP M

FOUR OF ONE CHARACTER. 30 CENTS

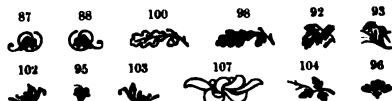

GROUP N

FOUR OF ONE CHARACTER. 40 CTS PER FONT \$3.00

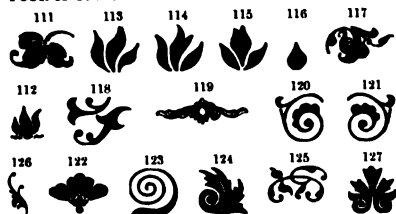

GROUP O

FOUR OF ONE CHARACTER. 40 CENTS

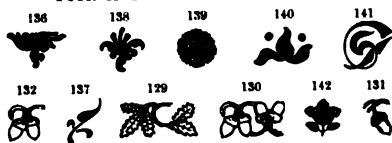

GROUP P

FOUR OF ONE CHARACTER. 40 CENTS



FOUR OF ONE CHARACTER. 50 CENTS



FOUR OF ONE CHARACTER. 40 CENTS

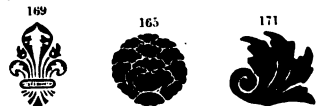

GROUP R



GROUP Q



GROUP V

FOUR OF ONE CHARACTER. 30 CTS. PER FONT \$1.50

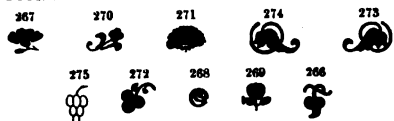

GROUP X

FOUR OF ONE CHARACTER 40 CENTS



GROUP W

FOUR OF ONE CHARACTER. 40 CTS. PER FONT \$2.50

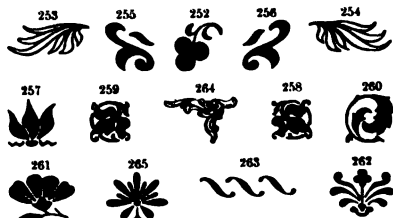

GROUP Y

FOUR OF ONE CHARACTER. 40 CENTS

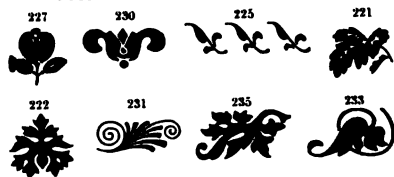

TWO OF ONE CHARACTER. 30 CENTS



TWO OF ONE CHARACTER. 25 CENTS

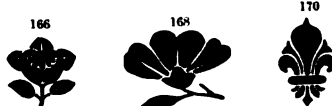

COLLINS FLORETS

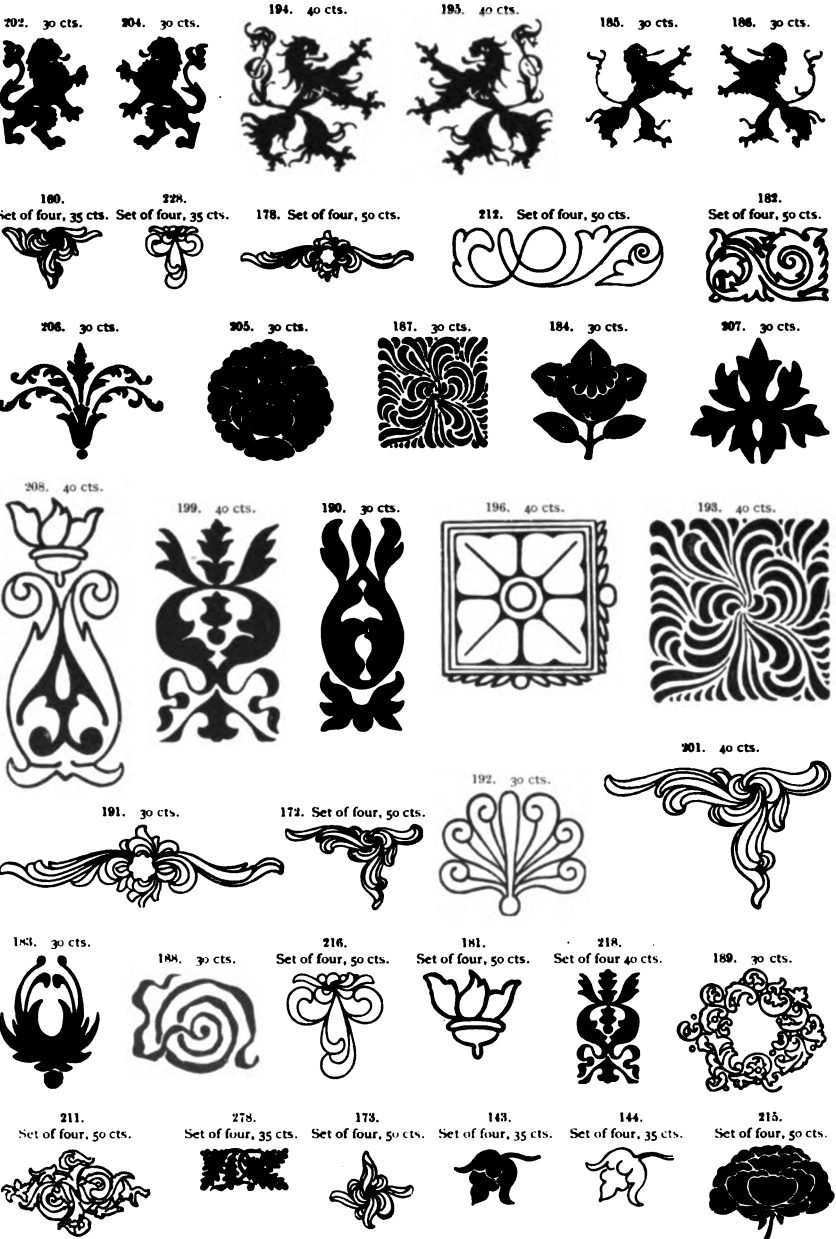

ELZEVIR FLORETS

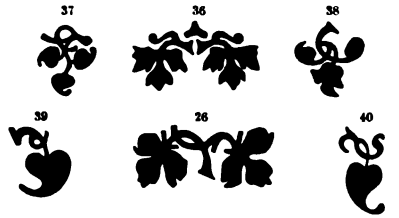
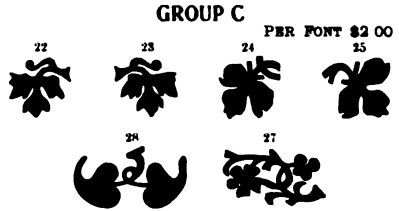
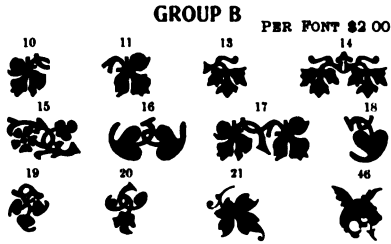
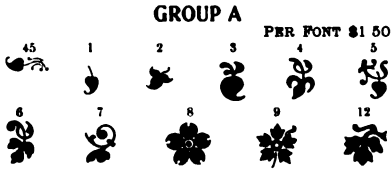

Florets of Groups C and D are made for printing over each other in different colors. See page 603 for color effect.

HAPGOOD FLORETS

CAST ON 48 POINT BODY

SINGLE CHARACTER 25 CENTS

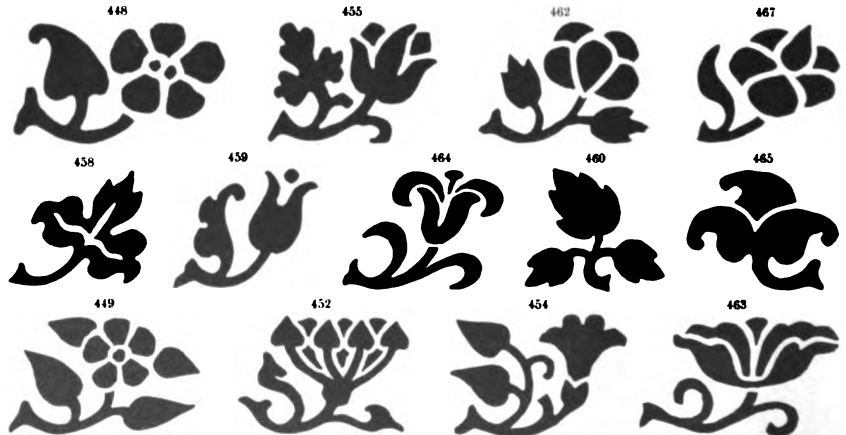

CHRISTMAS ORNAMENTS

All characters except 280-A put up in sets of four at 50 cents per set

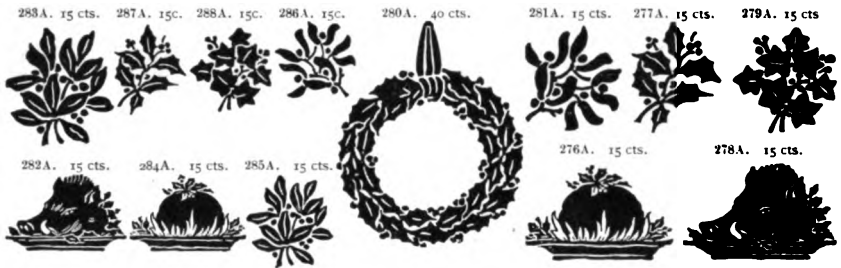

CLASSIC ORNAMENTS

PER FONT 86 25

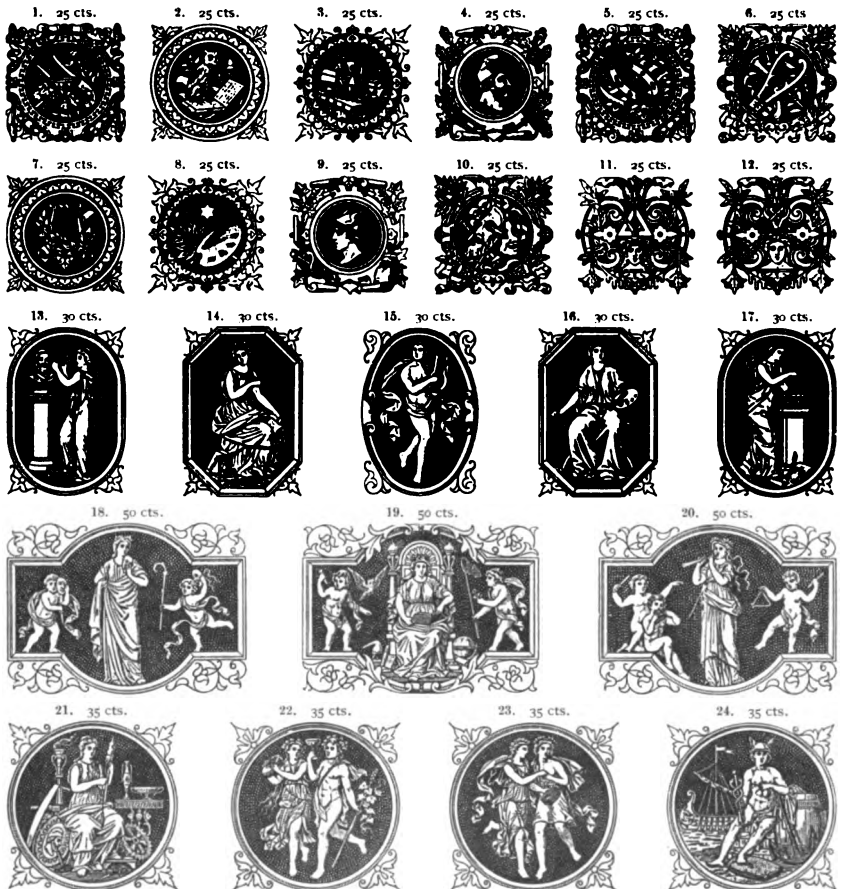

All Ornaments on this page are cast in type mould

HAPPY THOUGHTS

GROUP F

Each character put up in sets of four at 40 cents per set

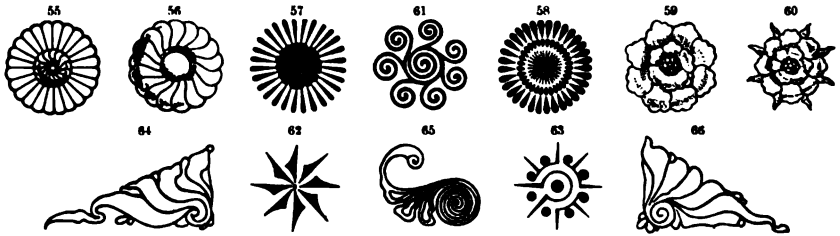

GROUP K

Each character put up in sets of four at 50c. per set

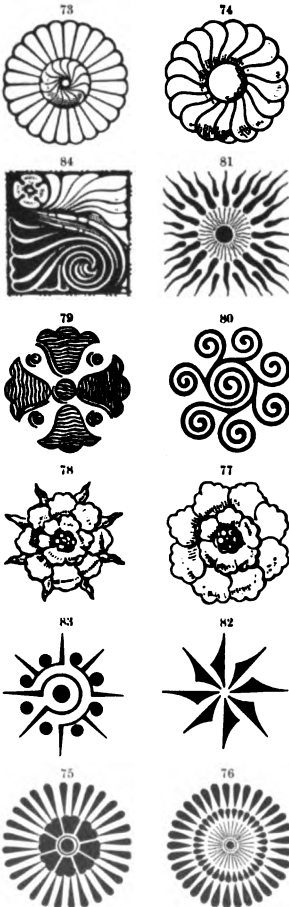

GROUP G

Each character 40 cents singly



GROUP E

Each character 35 cents singly

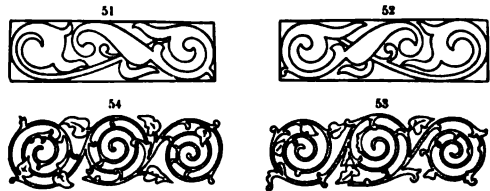

GROUP L

Each character put up in sets of four at 40 cents per set



GROUP H

Each character put up in sets of four at 50 cents per set

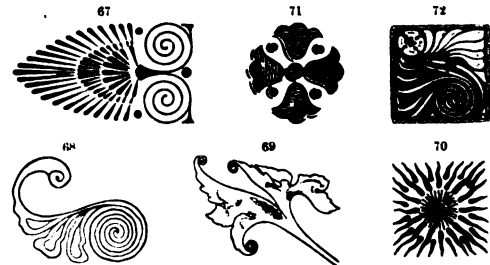

TWO-COLOR BORDERS

These Borders also shown in one color on pages 600, 634 and 615-617

18 POINT FLORENTINE BORDER NO. 229

18 POINT OOUTOUR BORDER NO. 270



EACH, 30 INCHES, \$1 60

12 POINT ART BORDER NO. 5, TINT

12 POINT ART BORDER NO. 5, OPEN



EACH, 60 INCHES, \$1 60

18 POINT ART BORDER NO. 7, TINT

18 POINT ART BORDER NO. 7, OPEN

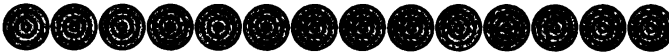

EACH, 60 INCHES, \$2 00

18 POINT ART BORDER NO. 4, TINT

18 POINT ART BORDER NO. 4, OPEN



EACH, 60 INCHES, \$2 00

24 POINT ART BORDER NO. 3, TINT

24 POINT ART BORDER NO. 3, OPEN



EACH, 36 INCHES, \$1 65

24 POINT ART BORDER NO. 7, TINT

24 POINT ART BORDER NO. 6



EACH, 36 INCHES, \$1 65

24 POINT ART BORDER NO. 9

24 POINT ART BORDER NO. 10

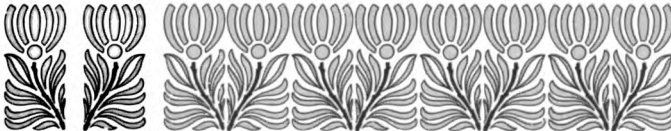

EACH, 36 INCHES, \$1 65

Printed with Nathan's Fine Union Black F, per pound, \$3.00; Tints Nos. 1 and 5, per pound, \$1.00 each. Prices subject to liberal discount.

18 POINT LAUREL BORDER

EACH, 36 INCHES, \$2 00

18 POINT LAUREL BORDER NO. 2

RED, WHITE AND BLUE BORDER

18 POINT, 42 INCHES EACH
COLOR. \$5 30

18 POINT CONTOUR BORDER NO. 257
18 POINT COLLINS BORDER NO. 198



EACH, 30 INCHES, \$1 50

18 POINT CONTOUR BAND NO. 258
18 POINT COLLINS BAND NO. 221



EACH, 30 INCHES \$1 50

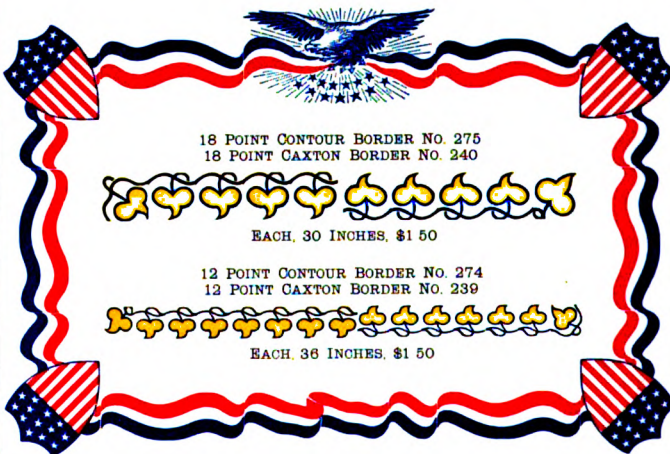

18 POINT CONTOUR BORDER NO. 275
18 POINT CAXTON BORDER NO. 240



EACH, 30 INCHES, \$1 50

12 POINT CONTOUR BORDER NO. 274
12 POINT CAXTON BORDER NO. 239



EACH, 36 INCHES, \$1 50

16 POINT CONTOUR BORDER NO. 267
16 POINT FLORENTINE BORDER NO. 158

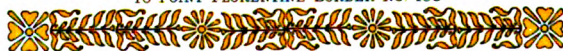

EACH, 30 INCHES, \$1 50

24 POINT COLLINS BAND NO. 217
24 POINT COLLINS BAND NO. 211



EACH, 20 INCHES, \$1 50

These Borders also shown in one color on pages 603, 608 and 609

Printed with Nathan's Fine Union Black F, per pound, \$3.00; Scarlet Lake, per pound, \$4.00; Milori Blue, per pound, \$3.00; and Sulphur Yellow, Dark, per pound, \$2.00. Prices subject to liberal discount.

UNION BORDER

18 POINT, 42 INCHES, \$2 65



The Red, White and Blue Border and Union Border are specially appropriate for Patriotic Printing and Political Occasions, Banquets, Rallies, and Military Organizations.

**44 POINT AMERICAN FLAGS FOR TWO COLORS
\$2 50 PER HALF DOZEN OF EACH COLOR**

ELZEVR FLORETS

GROUP C	GROUP D

PER FONT EACH \$2 00

For other sizes of Elzevir Florets, for one color, see page 598

36 POINT FLAG BORDER NO. 2, FOR TWO COLORS, 18 INCHES \$4 50

For other sizes of Flag Border, shown in one color, see page 639

Printed with Nathan's Fine Union Black F, per pound, \$3.00; Scarlet Lake, per pound, \$4.00; Milori Blue, per pound, \$3.00; and Sulphur Yellow, Dark, per pound, \$2.00. Prices subject to liberal discount.

TWO-COLOR BORDERS

These Borders also shown in one color on pages 633, 608 and 609

18 POINT CONTOUR BORDER NO. 261

18 POINT COLLINS BORDER NO. 173

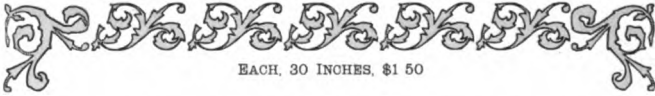

EACH, 30 INCHES, \$1 50

24 POINT CONTOUR BORDER NO. 259

24 POINT COLLINS BORDER NO. 196



EACH, 20 INCHES, \$1 50

24 POINT CONTOUR BORDER NO. 266

24 POINT FLORENTINE BORDER NO. 234



EACH, 30 INCHES, \$1 50

24 POINT CONTOUR BORDER NO. 268

24 POINT FLORENTINE BORDER NO. 162



EACH, 20 INCHES, \$1 50

42 POINT CONTOUR BAND NO. 296

42 POINT COLLINS BAND NO. 193



EACH 12 INCHES, \$1 50

42 POINT CONTOUR BAND NO. 297

42 POINT COLLINS BAND NO. 204



EACH, 12 INCHES, \$1 50

Printed with Nathan's Fine Union Black F, per pound, \$3.00; Tints Nos. 1 and 5, per pound, \$1.00 each. Prices subject to liberal discount.

18 POINT REGAL BORDER

EACH, 36 INCHES, \$2 00

18 POINT REGAL BORDER NO. 2

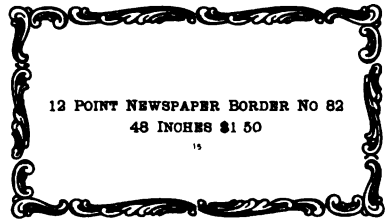
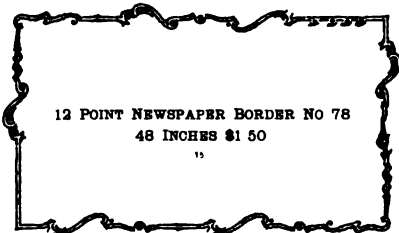
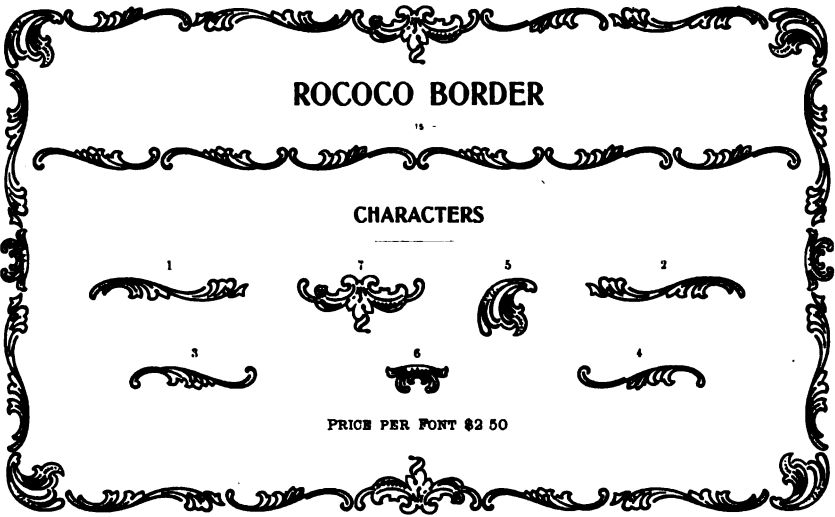

30 POINT BORDER NO 1 15

18 INCHES \$1 50

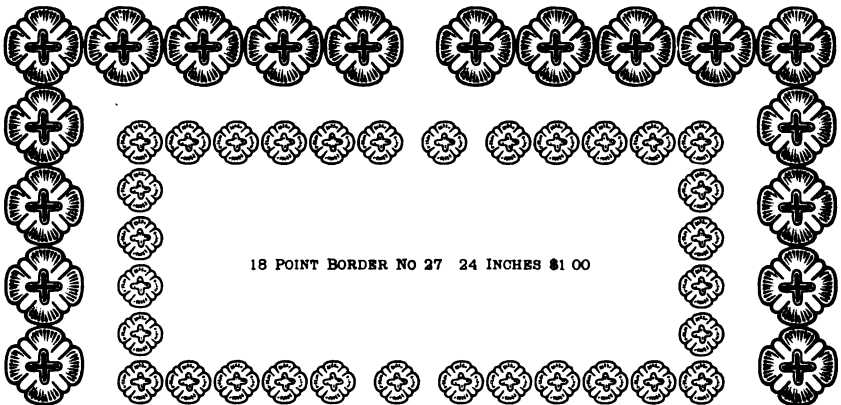

CAXTON BORDERS

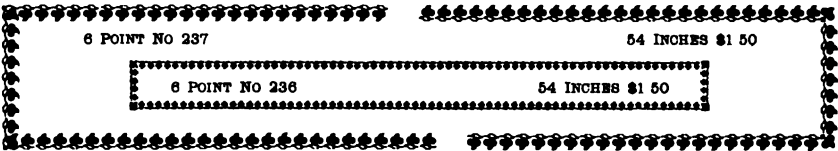
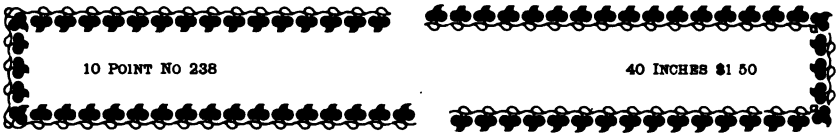
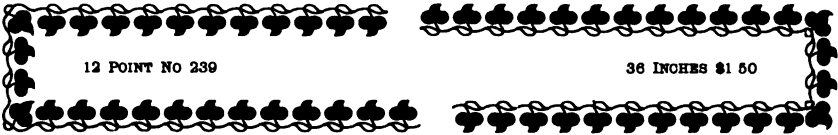

ELZEVIR BORDERS AND BANDS



FLORENTINE BORDERS

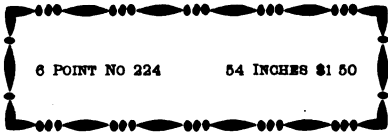

6 POINT NO 224 54 INCHES \$1 50



6 POINT NO 225 54 INCHES \$1 50

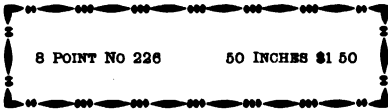

8 POINT NO 226 50 INCHES \$1 50

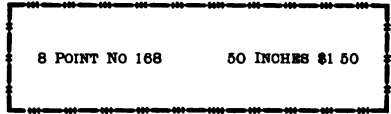

8 POINT NO 168 50 INCHES \$1 50

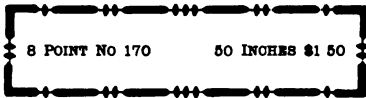

8 POINT NO 170 50 INCHES \$1 50

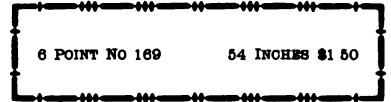

6 POINT NO 169 54 INCHES \$1 50

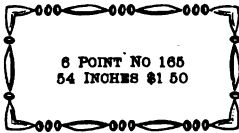

6 POINT NO 165 54 INCHES \$1 50

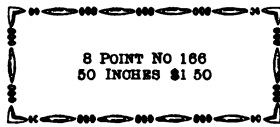

8 POINT NO 166 50 INCHES \$1 50



6 POINT NO 167 50 INCHES \$1 50



8 POINT NO 161 50 INCHES \$1 50



12 POINT NO 151 36 INCHES \$1 50



8 POINT NO 227 50 INCHES \$1 50



8 POINT NO 152 50 INCHES \$1 50



8 POINT NO 156 50 INCHES \$1 50



12 POINT NO 155 36 INCHES \$1 50



12 POINT NO 164 36 INCHES \$1 50



16 POINT NO 154 30 INCHES \$1 50



18 POINT NO 163 30 INCHES \$1 50



12 POINT NO 149 36 INCHES \$1 50



24 POINT NO 162 20 INCHES \$1 50



18 POINT NO 148 30 INCHES \$1 50

CONTOUR BANDS AND BORDERS

Patent applied for

24 POINT No 260

20 INCHES \$1 50

24 POINT No 259

20 INCHES \$1 50



24 POINT No 266

20 INCHES \$1 50



42 POINT No 296

12 INCHES \$1 50



18 POINT No 276

30 INCHES \$1 50

12 POINT No 274

36 INCHES \$1 50

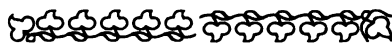

6 POINT No 272

54 INCHES \$1 50

10 POINT No 273

40 INCHES \$1 50

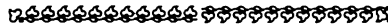

Fonts of Borders Nos. 272, 273, 274 and 275 include two styles of corners

18 POINT No 268

30 INCHES \$1 50



18 POINT No 265

30 INCHES \$1 50



18 POINT No 269

30 INCHES \$1 50

24 POINT No 268

20 INCHES \$1 50

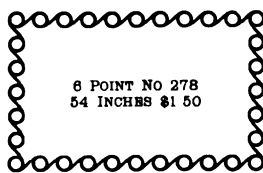

6 POINT No 278
54 INCHES \$1 50



9 POINT No 279
46 INCHES \$1 50

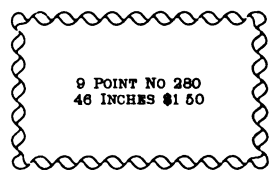

9 POINT No 280
46 INCHES \$1 50

Several of these Borders are shown in two colors on pages 602 and 604

CONTOUR BANDS AND BORDERS

Patent applied for

36 POINT NO 262

18 INCHES \$1 50

36 POINT NO 298

18 INCHES \$1 50



18 POINT NO 257

30 INCHES \$1 50

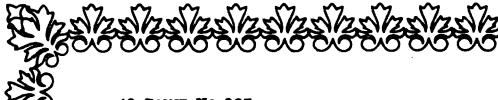

42 POINT NO 297

12 INCHES \$1 50



16 POINT NO 267

30 INCHES \$1 50

16 POINT NO 264

30 INCHES \$1 50

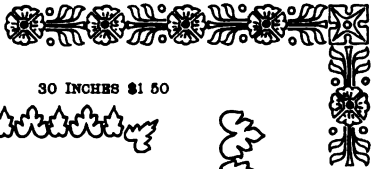
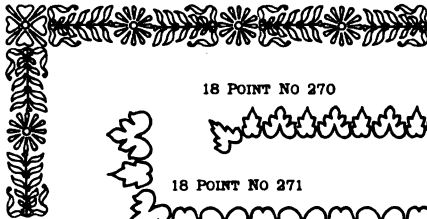

18 POINT NO 270

30 INCHES \$1 50



18 POINT NO 271

30 INCHES \$1 50

48 POINT NO 295

12 INCHES \$1 50

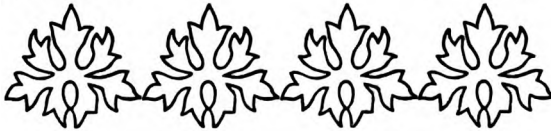

18 POINT NO 261

30 INCHES \$1 50



30 POINT NO 263

20 INCHES \$1 50



Several of these Borders are shown in two colors on pages 601, 602 and 604

BARTA BORDERS

Patent applied for

30 POINT NO 243

20 INCHES \$1 50

30 POINT NO 251

20 INCHES \$1 50



24 POINT NO 289

20 INCHES \$1 50



18 POINT NO 241 30 INCHES \$1 50



18 POINT NO 250

30 INCHES \$1 50



24 POINT NO 284

20 INCHES \$1 50



18 POINT NO 291

30 INCHES \$1 50



24 POINT NO 242

20 INCHES \$1 50



24 POINT NO 281

20 INCHES \$1 50



18 POINT NO 248 30 INCHES \$1 50



18 POINT NO 247

30 INCHES \$1 50



18 POINT NO 246

30 INCHES \$1 50



12 POINT NO 282

36 INCHES \$1 50



36 POINT NO 287 18 INCHES \$1 50

36 POINT NO 288 18 INCHES \$1 50



72 POINT BARTA BORDER NO 294 24 INCHES \$3 00



48 POINT BARTA BORDER NO 263 12 INCHES \$1 50



18 POINT COLLINS BORDER NO 223 30 INCHES \$1 50



54 POINT BARTA BORDER NO 293 24 INCHES \$3 00



36 POINT BARTA BORDER NO 254 18 INCHES \$1 50

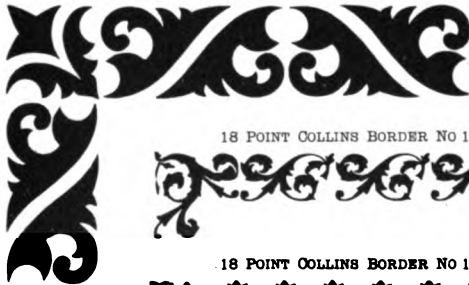

30 POINT COLLINS BORDER NO 203 20 INCHES \$1 50



18 POINT COLLINS BORDER NO 173 30 INCHES \$1 50



18 POINT COLLINS BORDER NO 198 30 INCHES \$1 50



24 POINT COLLINS BORDER NO 196 20 INCHES \$1 50



36 POINT COLLINS BORDER NO 172 18 INCHES \$1 50



24 POINT COLLINS BORDER NO 195 20 INCHES \$1 50

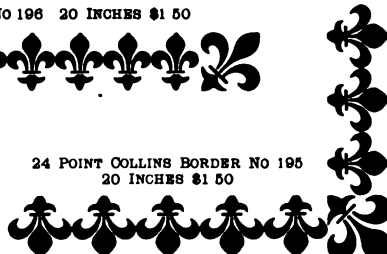

Several of these Borders are shown in two colors on pages 602 and 604

COLLINS BANDS

12 POINT No 175 36 INCHES \$1 50

12 POINT No 174 36 INCHES \$1 50

12 POINT No 202 36 INCHES \$1 50

12 POINT No 176 36 INCHES \$1 50

18 POINT No 216 30 INCHES \$1 50

18 POINT No 181 30 INCHES \$1 50

18 POINT No 182 30 INCHES \$1 50

18 POINT No 220 30 INCHES \$1 50

18 POINT No 218 30 INCHES \$1 50

18 POINT No 178 30 INCHES \$1 50

24 POINT No 188 20 INCHES \$1 50

24 POINT No 185 20 INCHES \$1 50

18 POINT No 214 30 INCHES \$1 50

24 POINT No 189 20 INCHES \$1 50

24 POINT No 209 20 INCHES \$1 50

30 POINT No 192 20 INCHES \$1 50

42 POINT No 193 12 INCHES \$1 50



42 POINT No 204 12 INCHES \$1 50

Several of these Borders are shown in two colors on page 604

ART BORDERS

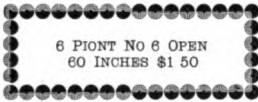

36 POINT NO 25 12 INCHES \$1 10



6 POINT NO 6 OPEN
60 INCHES \$1 50

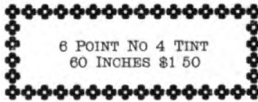

6 POINT NO 4 TINT
60 INCHES \$1 50

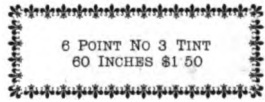

6 POINT NO 3 TINT
60 INCHES \$1 50

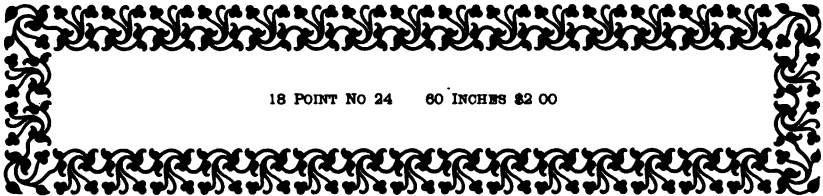

18 POINT NO 24 60 INCHES \$2 00



24 POINT NO 24
36 INCHES \$1 65



24 POINT NO 25
36 INCHES \$1 65

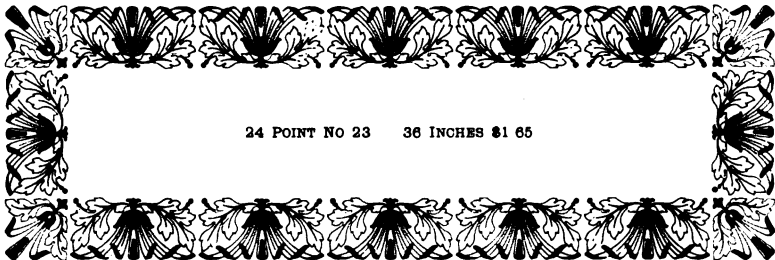

24 POINT NO 23 36 INCHES \$1 65

ART BORDERS

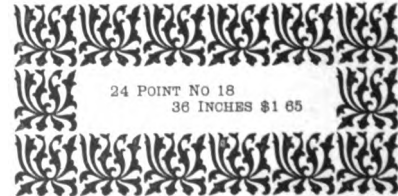
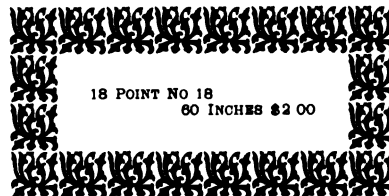
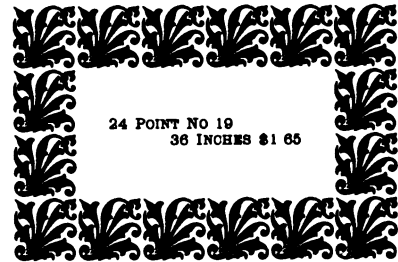
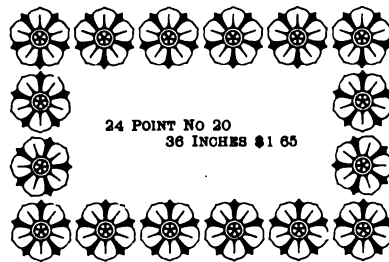
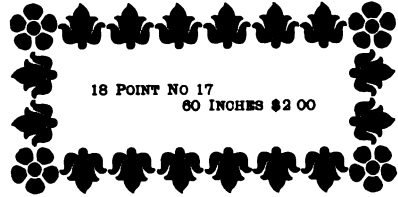
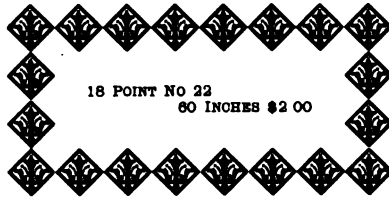
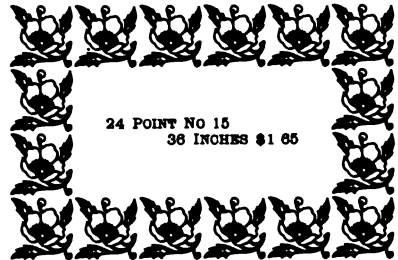
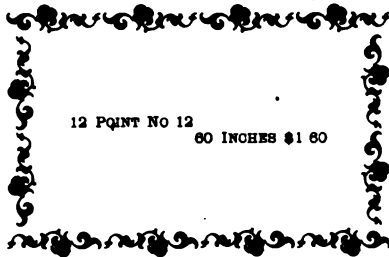
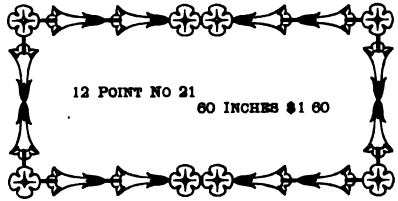
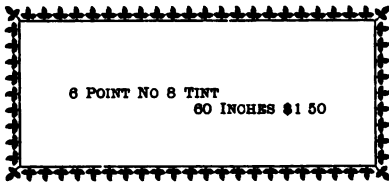

ART BORDERS

Art Borders Nos. 6, 9 and 10, all sizes, are made to register for two colors. See page 601

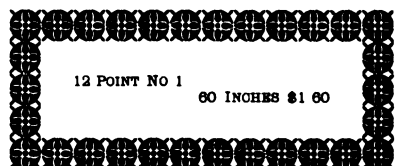
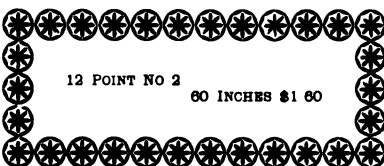
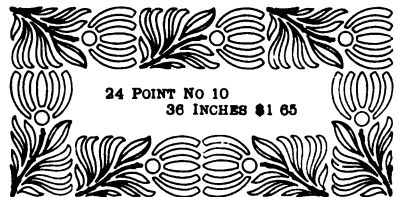
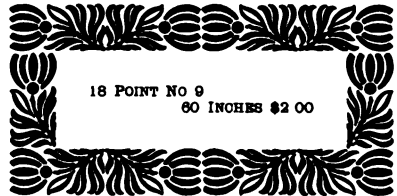
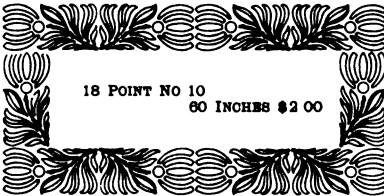
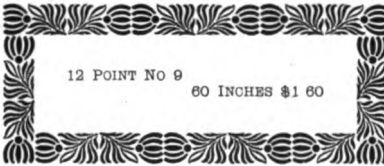
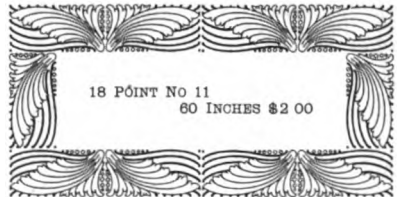
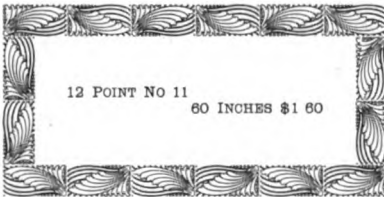
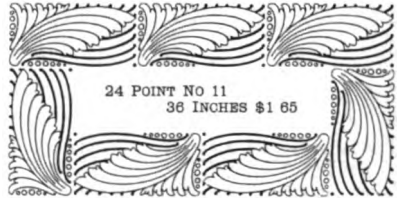

ART BORDERS

These Borders are made to register for two colors. See page 601

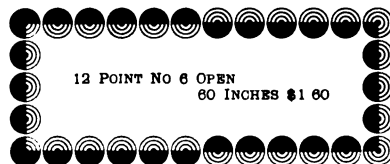
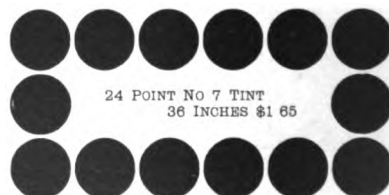
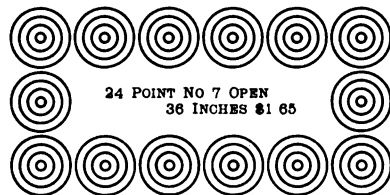
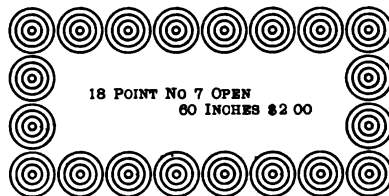
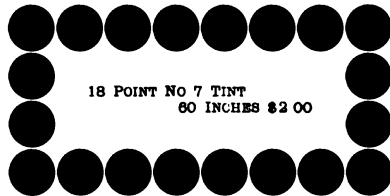
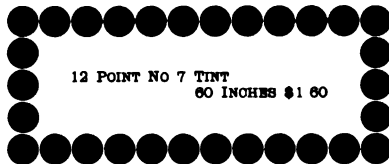
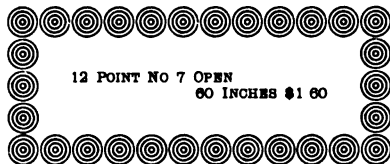
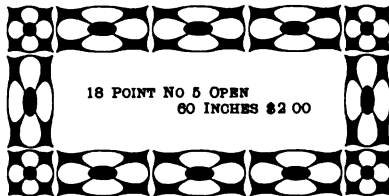
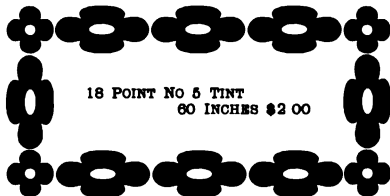
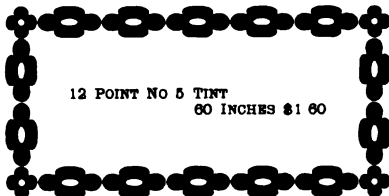
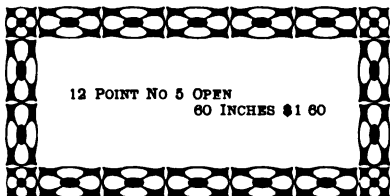

ART BORDERS

These Borders are made to register for two colors. See page 601

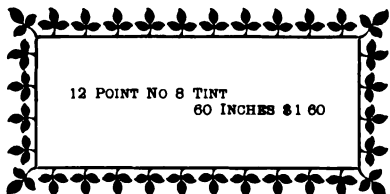
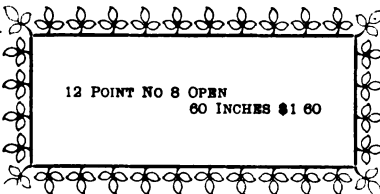
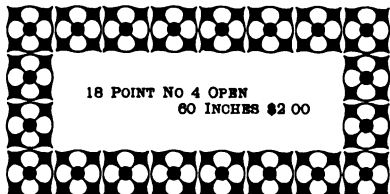
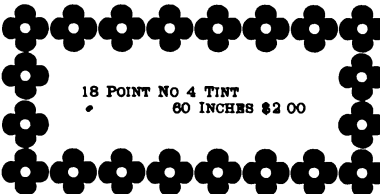
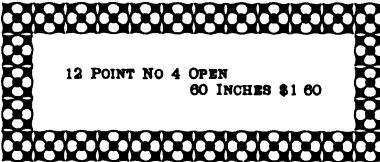
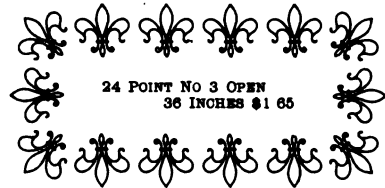
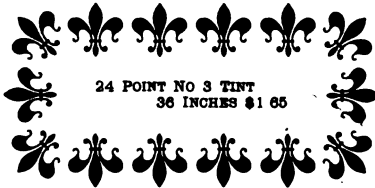
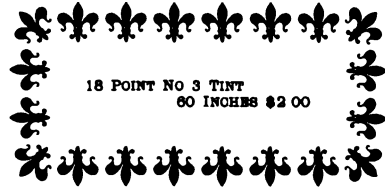
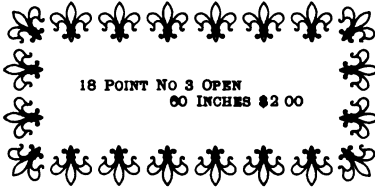
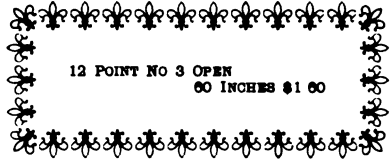
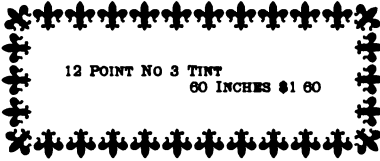

FLAME BORDERS

Each size is furnished with Round and Square Corners

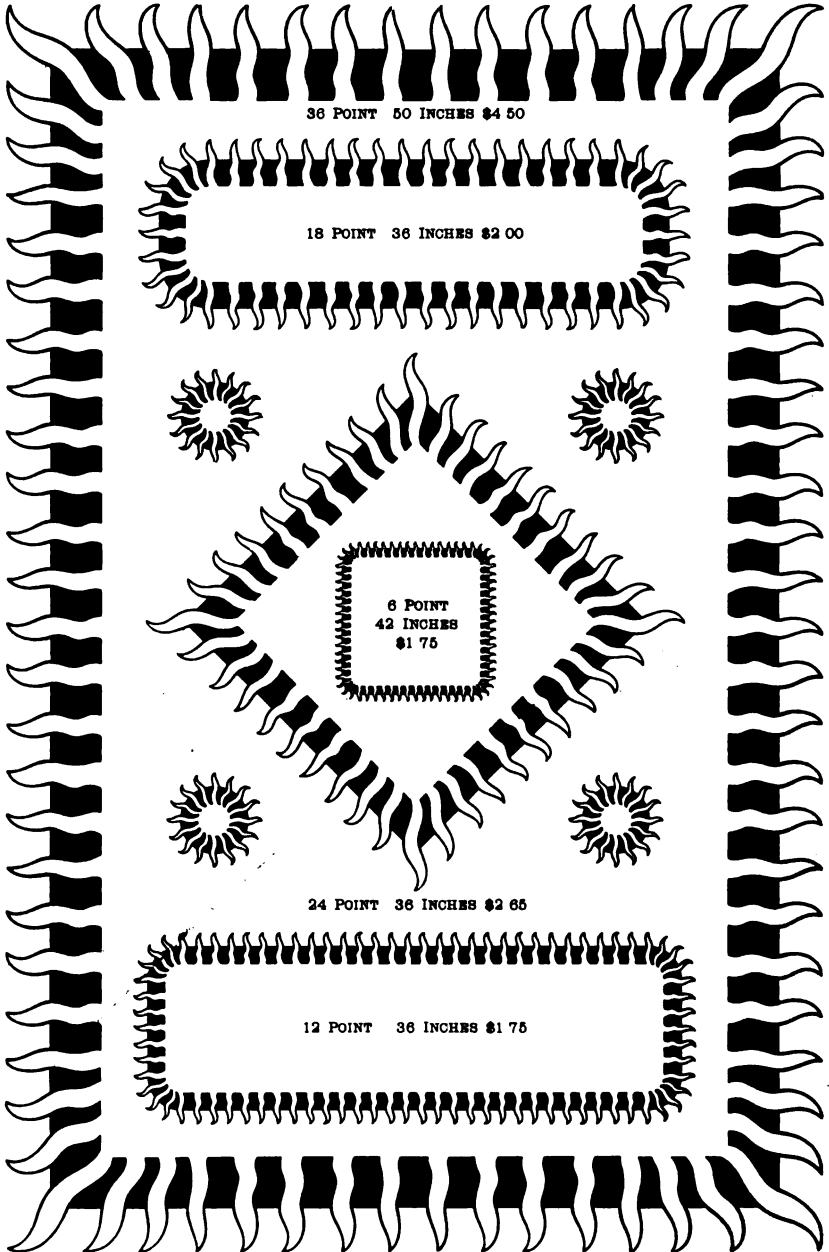

NEWSPAPER BORDERS

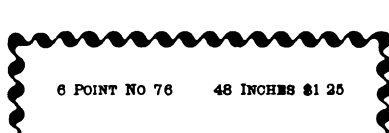
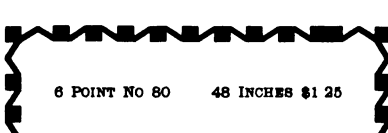
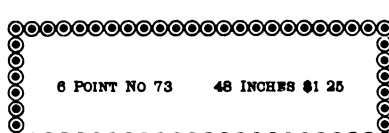
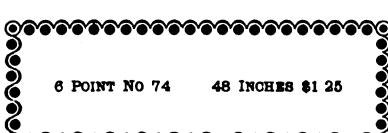
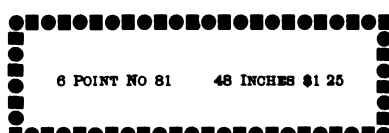
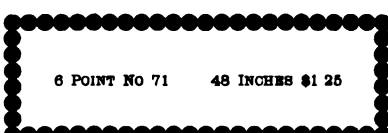
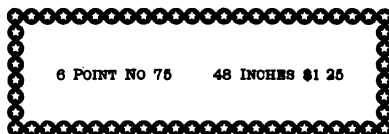
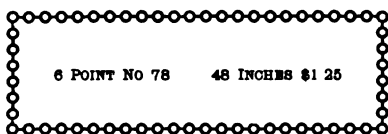
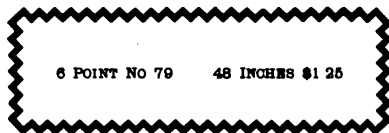
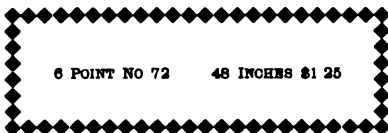
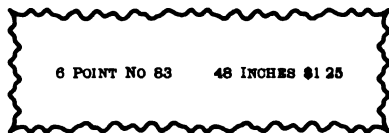
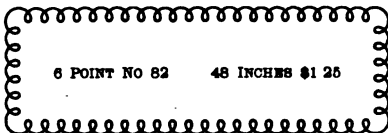
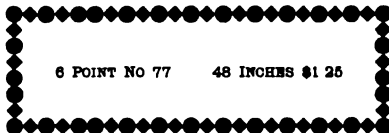

NEWSPAPER BORDERS

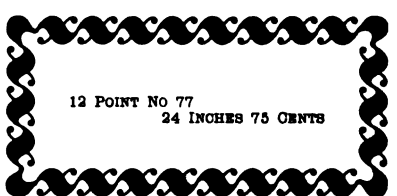
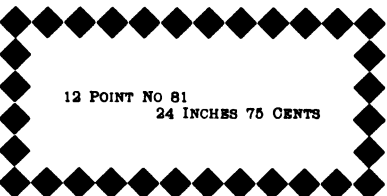
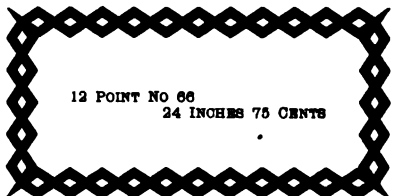
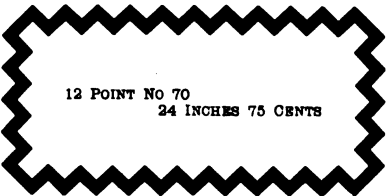
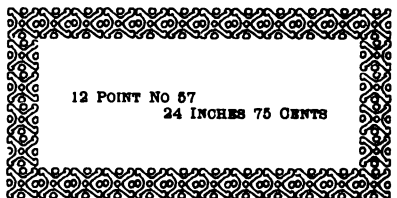
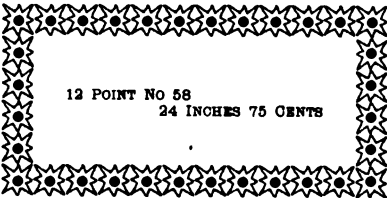
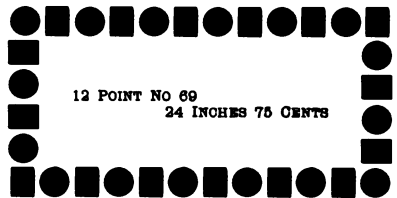
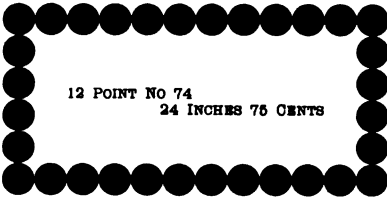
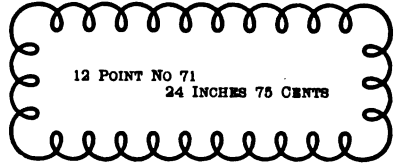
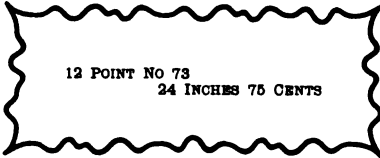
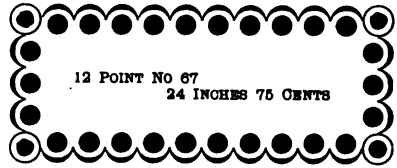
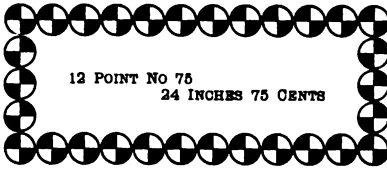

NEWSPAPER BORDERS

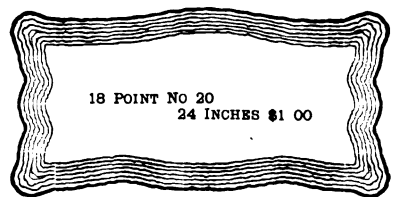
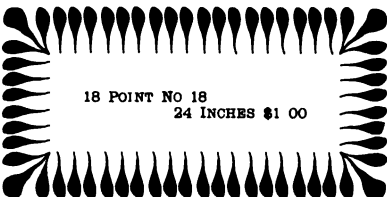
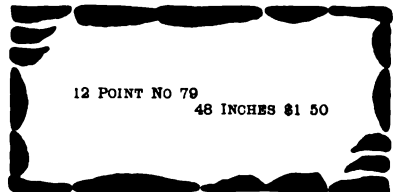
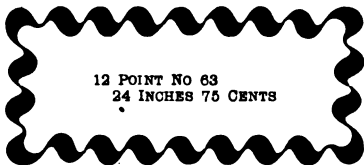
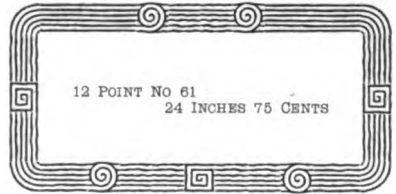
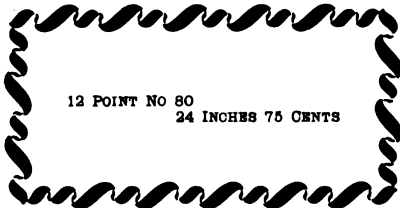
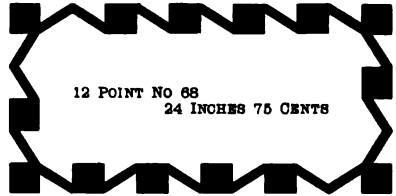
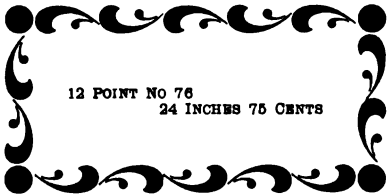
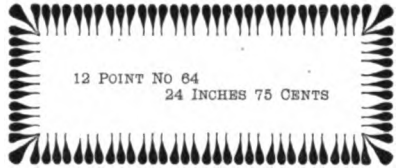
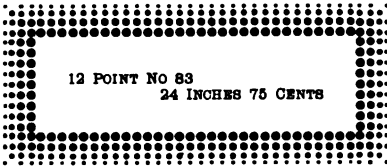
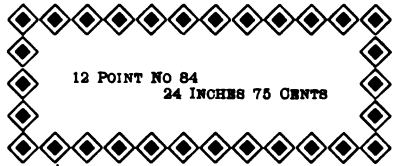
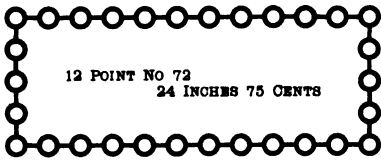

NEWSPAPER BORDERS

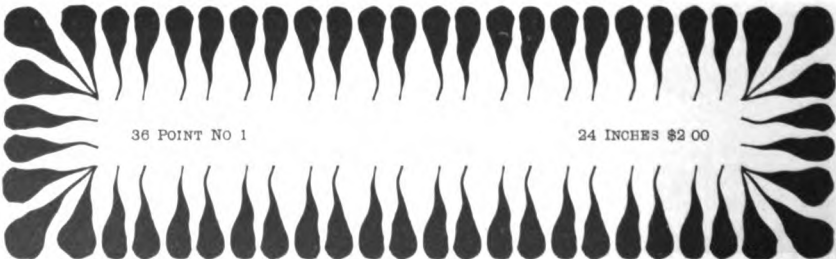
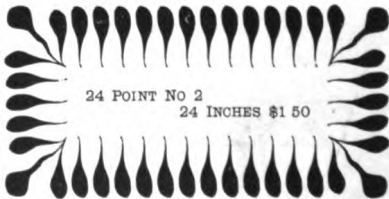
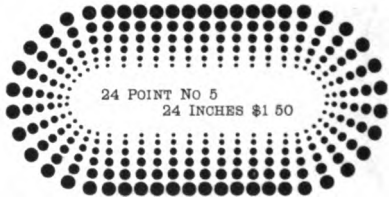
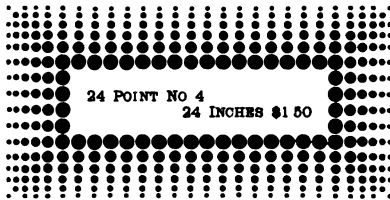
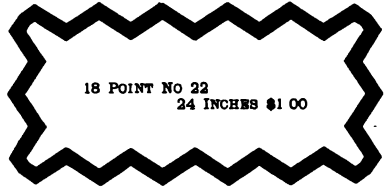
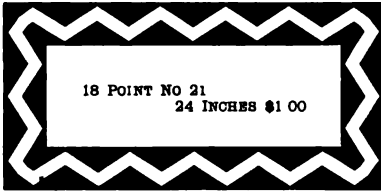
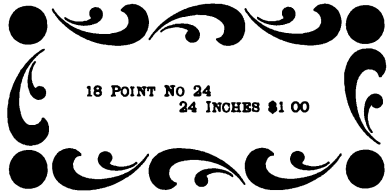
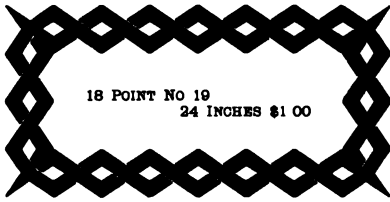

NEWSPAPER BORDERS

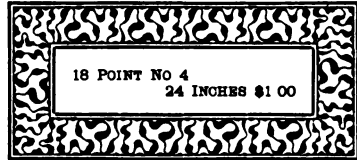
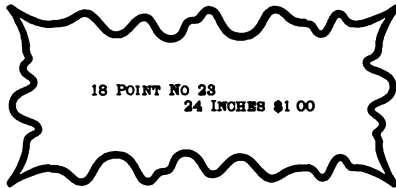
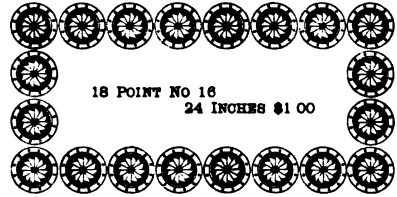
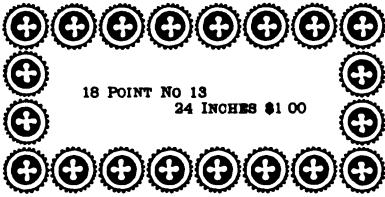
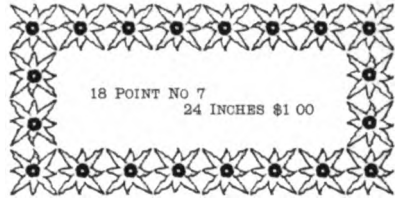
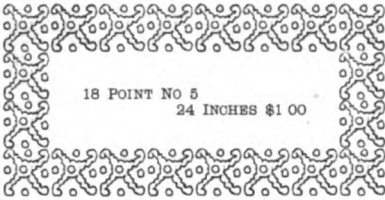

EIGHTEEN POINT BORDERS

PER FONT, \$3 00



TWELVE POINT BORDERS

PER FONT \$2 50



No 1201



No 1227



No 1207



No 1228



No 1209



No 1232



No 1220



No 1233



No 1225



No 1234

TWENTY-FOUR POINT BORDERS

PER FONT \$3 50



No 2401

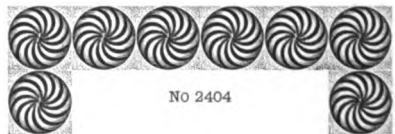

No 2404

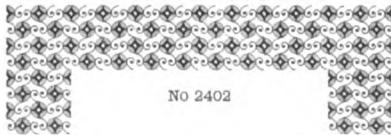

No 2402

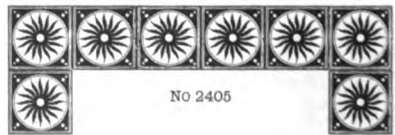

No 2405

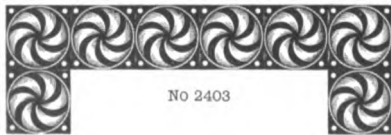

No 2403

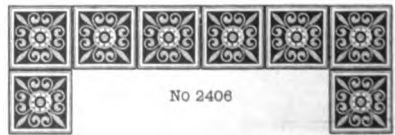

No 2406

HALF NONPAREIL BORDERS

COMPLETE FONT #2 25 10 FEET LONG

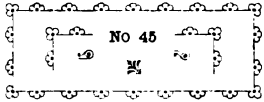
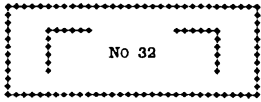
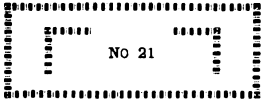
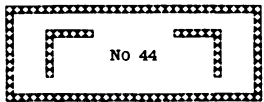
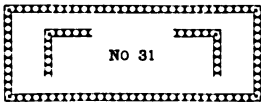
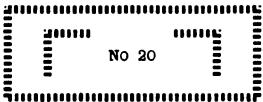
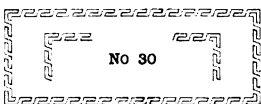
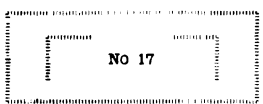
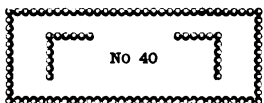
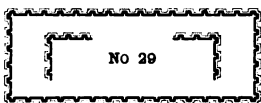
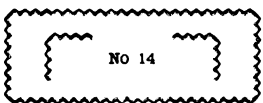
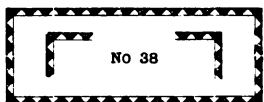
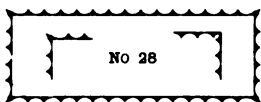
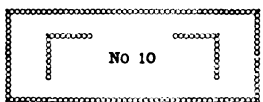
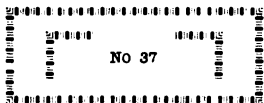
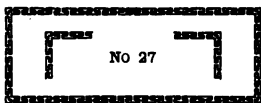
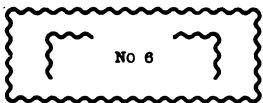
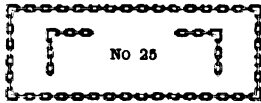
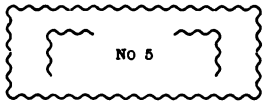
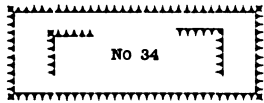
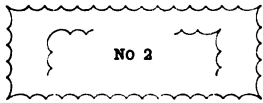
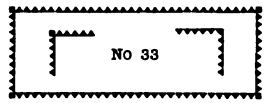
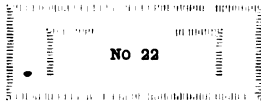

NONPAREIL BORDERS

COMPLETE FONT 82 60 10 FEET LONG

HALF FONT 81 40 5 FEET LONG

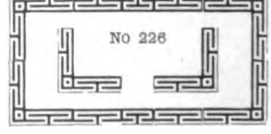
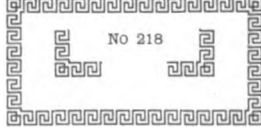
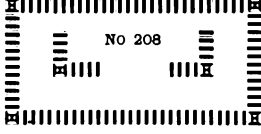
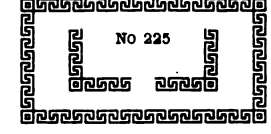
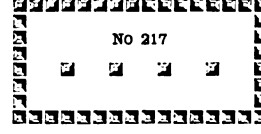
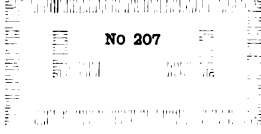
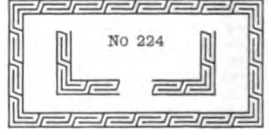
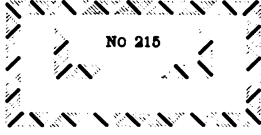
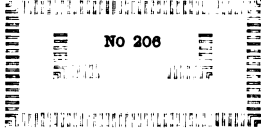
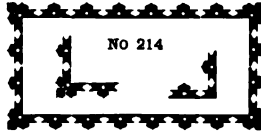
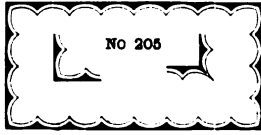
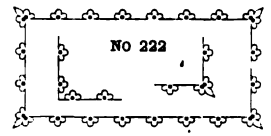
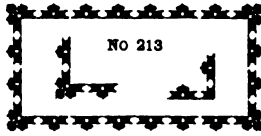
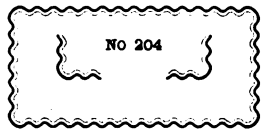
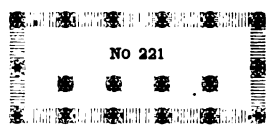
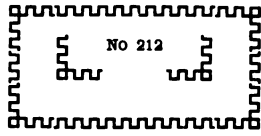
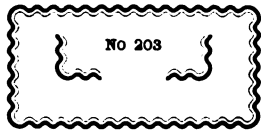
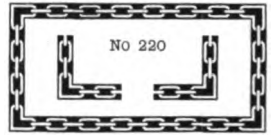
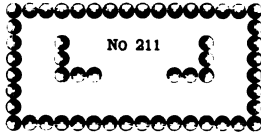
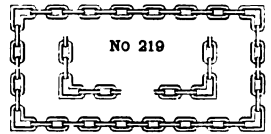
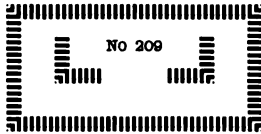

NONPAREIL BORDERS

COMPLETE FONT \$2 60 10 FEET LONG

HALF FONT \$1 40 5 FEET LONG

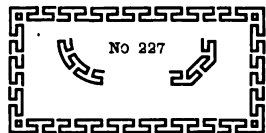
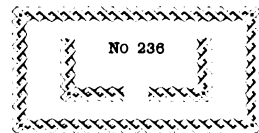
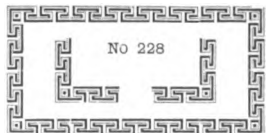
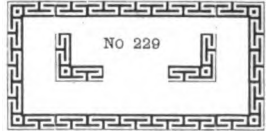
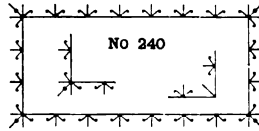
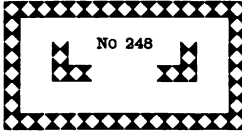
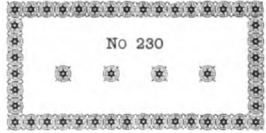
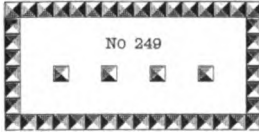
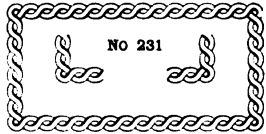
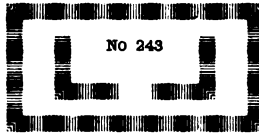
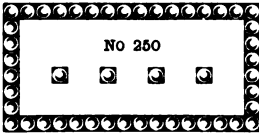
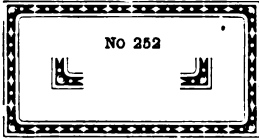
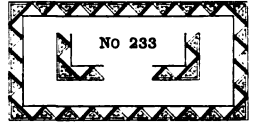
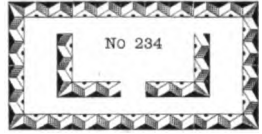
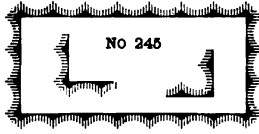
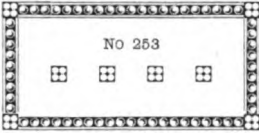

NONPAREIL AND ONE-HALF BORDERS

COMPLETE FONT \$3 00 10 FEET LONG

HALF FONT \$1 60 5 FEET LONG

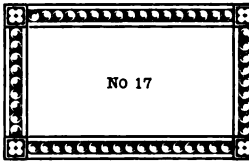
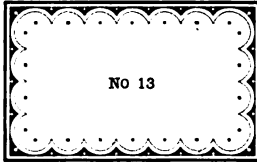
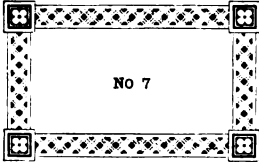
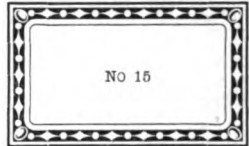
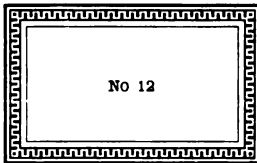
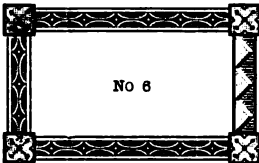
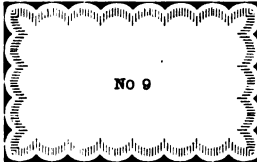
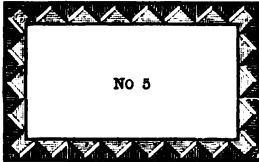

PICA BORDERS

COMPLETE FONT \$3 00 10 FEET LONG

HALF FONT \$1 60 5 FEET LONG

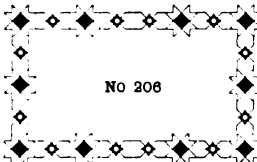
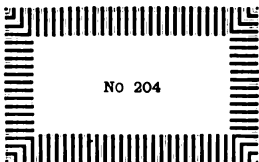
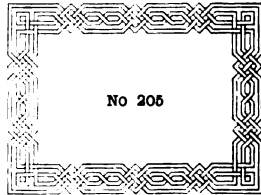
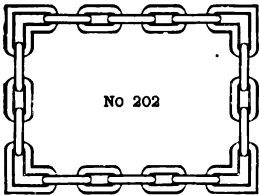

PICA BORDERS

COMPLETE FONT \$3 00 10 FEET LONG

HALF FONT \$1 60 5 FEET LONG

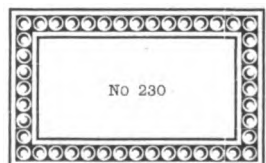
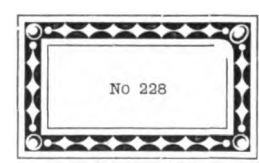
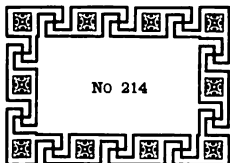
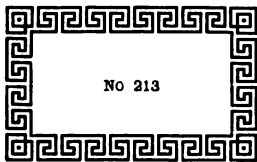
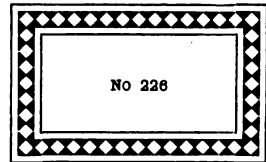
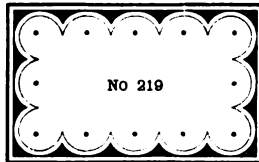
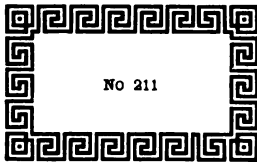
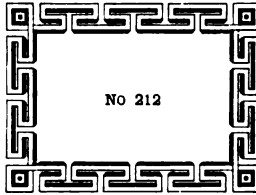
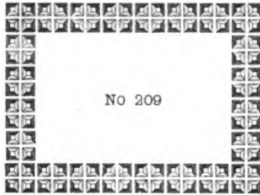

3-LINE NONPAREIL, 2- AND 3-LINE PICA BORDERS

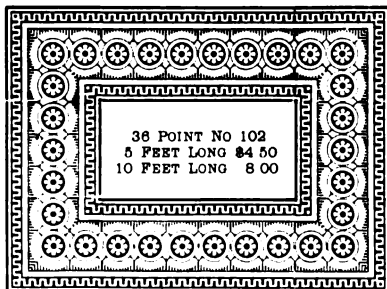
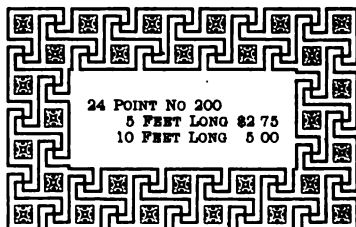
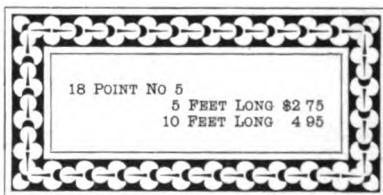
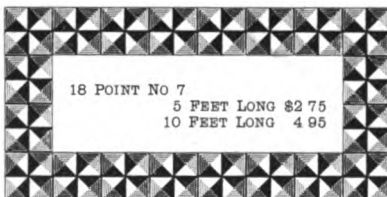
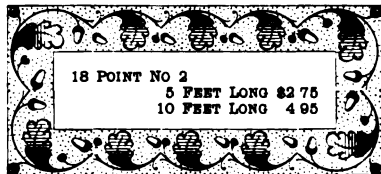
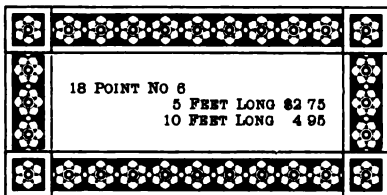
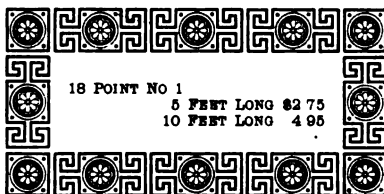
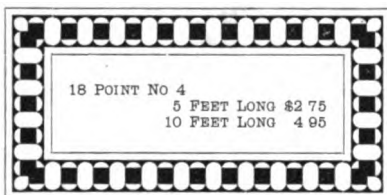

BRIER BORDER 15

PER FONT 18 INCHES \$2 00

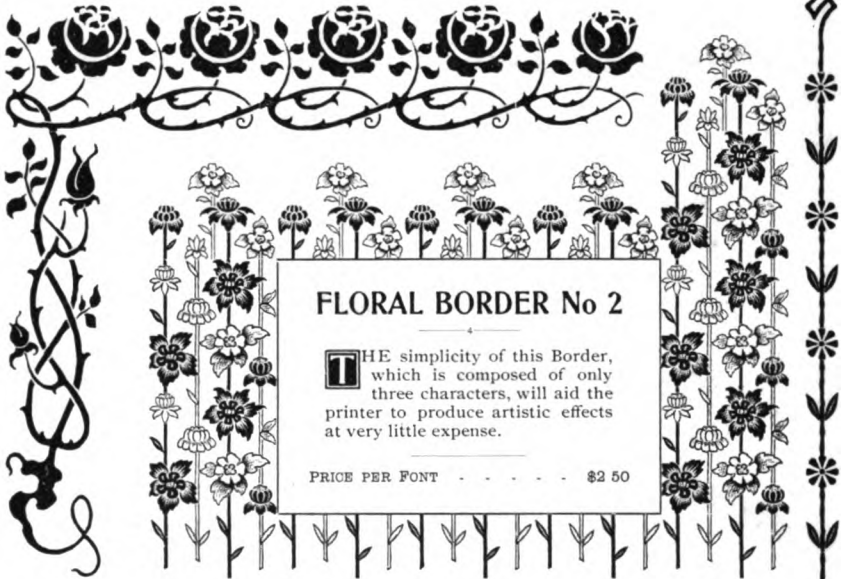

FLORAL BORDER No 2

THE simplicity of this Border, which is composed of only three characters, will aid the printer to produce artistic effects at very little expense.

PRICE PER FONT \$2 50



FLORAL BORDER No 1

PRICE PER FONT \$1 50

HOLLY BORDER No 1

The Nos. 2 and 3 Borders, when worked in Red and Green respectively, will be found appropriate for many occasions of festivity and for other purposes.



NO 1 \$3 00 | NO 2 (RED) \$3 00 | NO 3 (GREEN) \$3 00
EACH FONT CONTAINS 36 INCHES

ART BORDERS

18 POINT NO 25

60 INCHES \$2 00

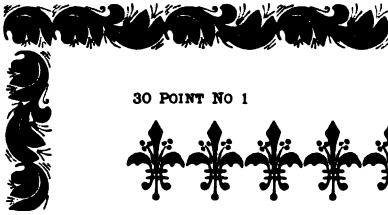

30 POINT NO 1

36 INCHES \$1 65



CENTRAL BANDS

12 POINT NO 1

24 INCHES 75 CENTS



12 POINT NO 2

24 INCHES 75 CENTS



18 POINT NO 1

24 INCHES \$1 00



18 POINT NO 2

24 INCHES \$1 00



24 POINT NO 1

24 INCHES \$1 50



24 POINT NO 2

24 INCHES \$1 50



POLKA-DOT BORDER

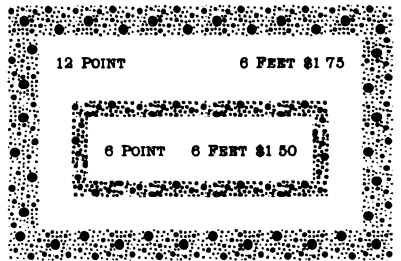
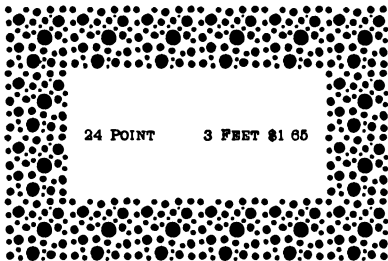

RUSTIC BAND BORDER

24 POINT

3 FEET \$1 65



POINTER BORDERS

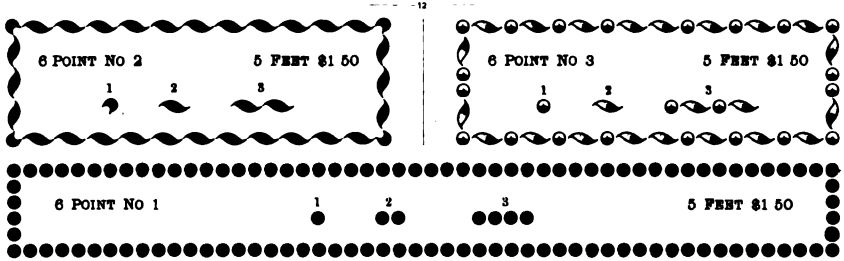

DARLING BORDERS

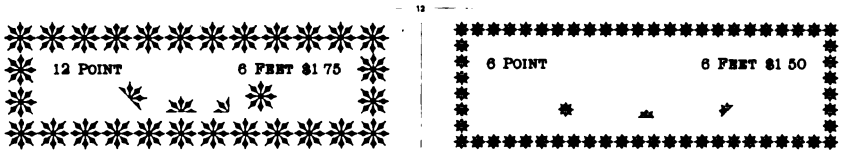

DAISY BORDERS

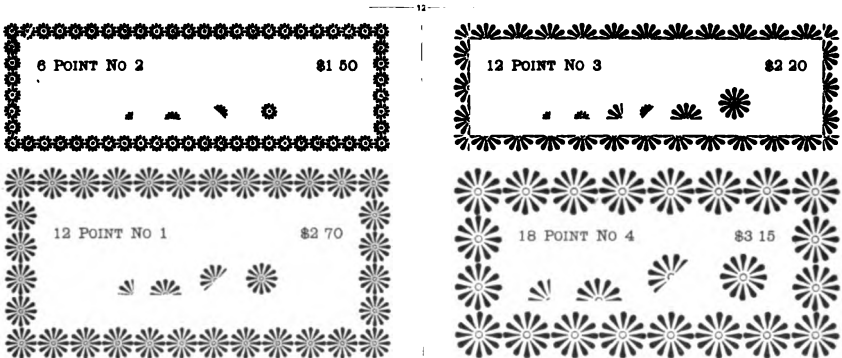

REGAL BORDERS

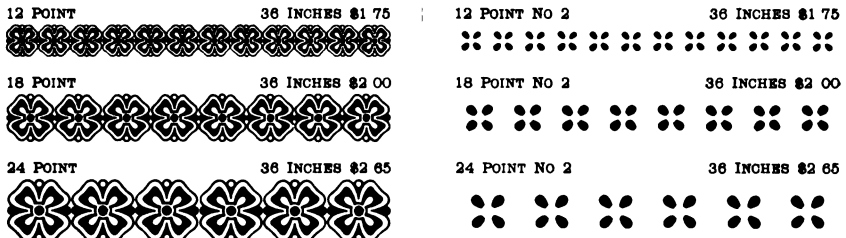

Regal Border No. 2 registers with Regal Border, making a pleasing combination in colors

LAUREL BORDERS

These Borders register for Colors

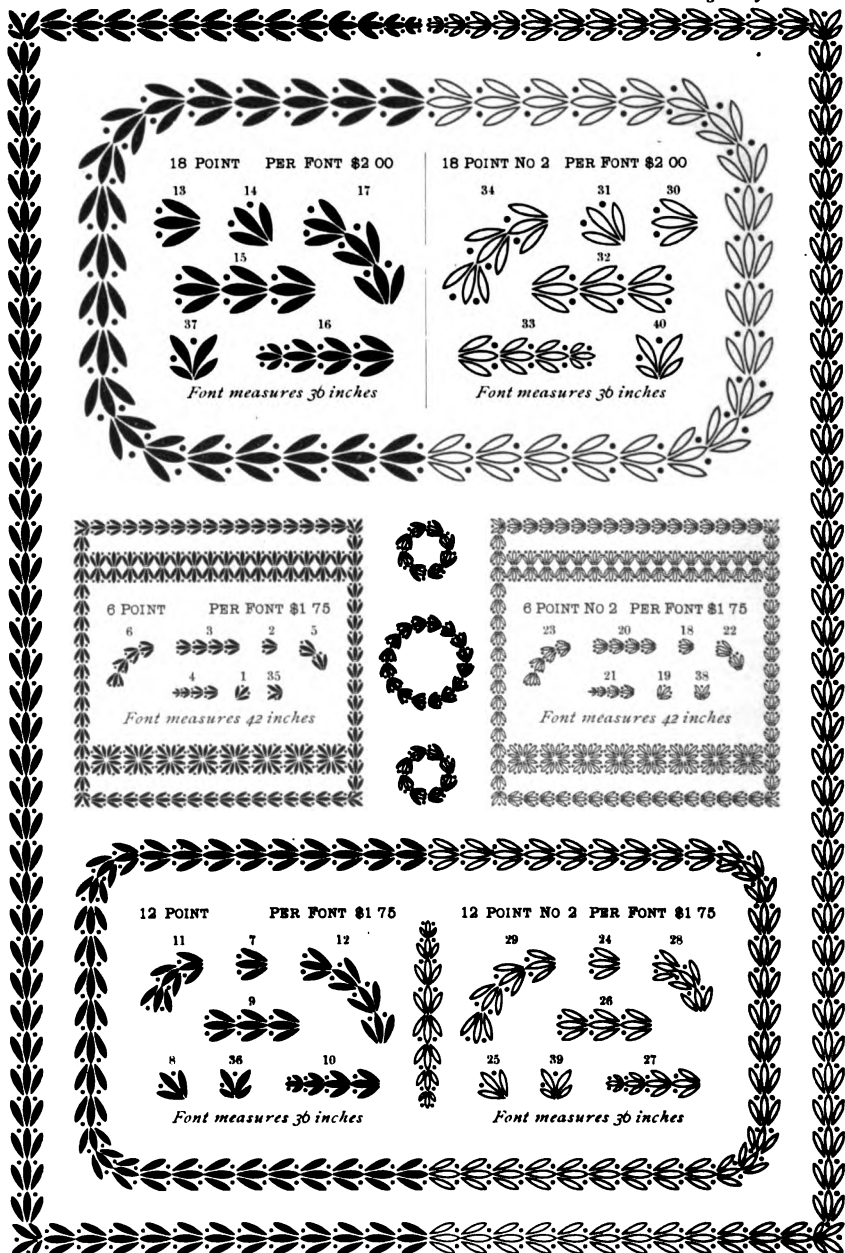

18 POINT PER FONT \$2 00

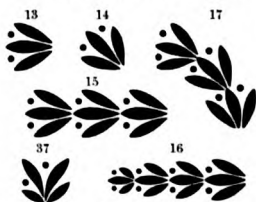

Font measures 36 inches

18 POINT NO 2 PER FONT \$2 00

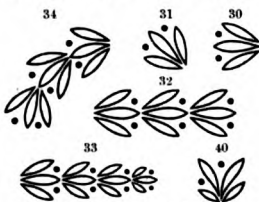

Font measures 36 inches

6 POINT PER FONT \$1 75



Font measures 42 inches

6 POINT NO 2 PER FONT \$1 75

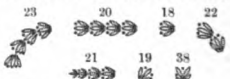

Font measures 42 inches

12 POINT PER FONT \$1 75

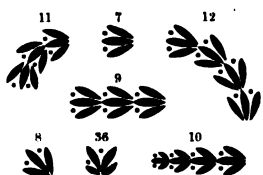

Font measures 36 inches

12 POINT NO 2 PER FONT \$1 75

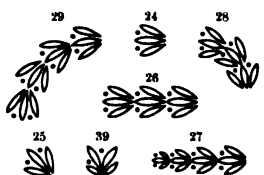

Font measures 36 inches

LAUREL ORNAMENTS

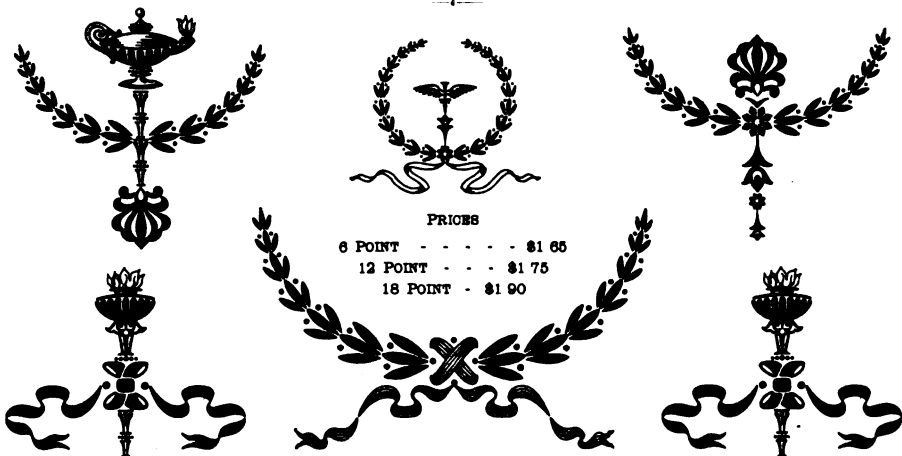

LAUREL ORNAMENTS

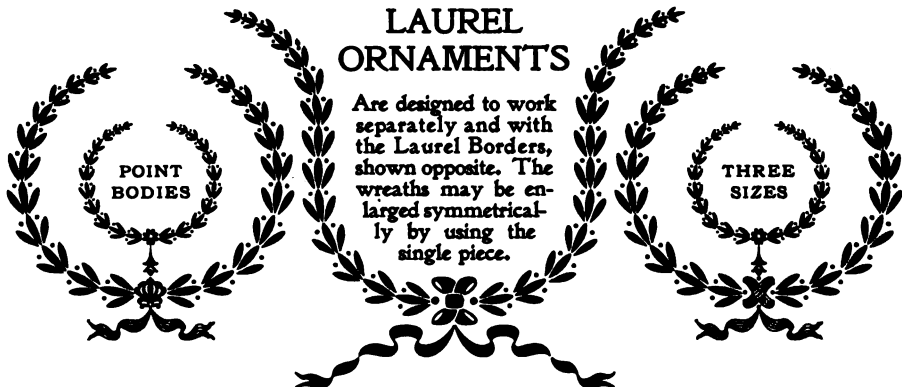

These Ornaments are cast in a cored type mould, with as little shoulder as possible on the inside of the wreaths, so that type lines may be set close up. A great variety of designs may be quickly and easily produced with these inexpensive Ornaments.

CHARACTERS OF 18 POINT LAUREL ORNAMENTS

The characters of 6 Point and 12 Point are nearly alike

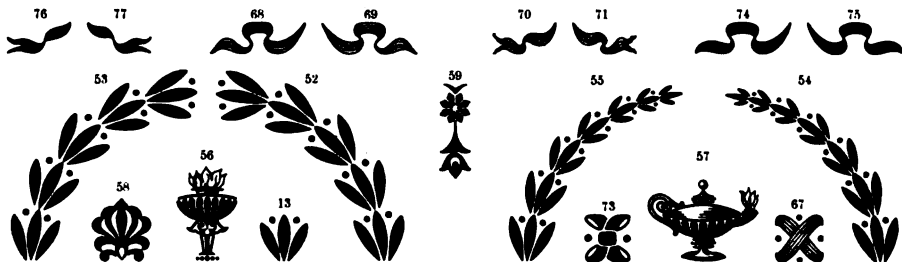

36 POINT NO 1

\$2 50

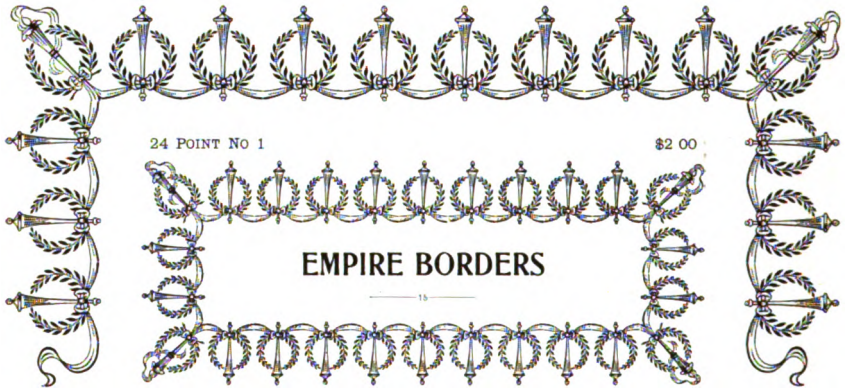

36 POINT NO 2

\$2 50



36 POINT NO 3

\$2 50

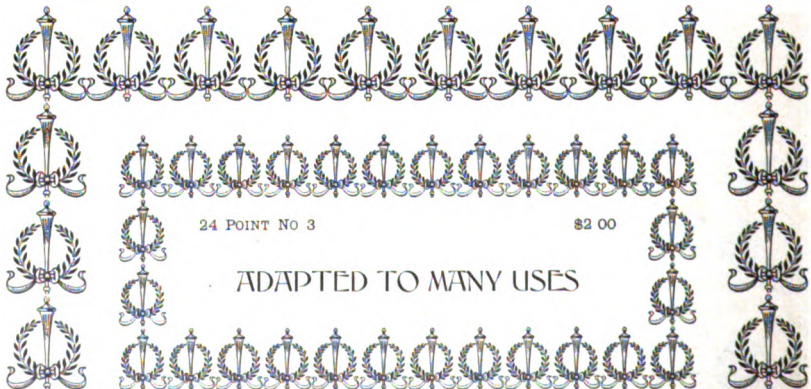

BARTH GEOMETRICAL BORDERS

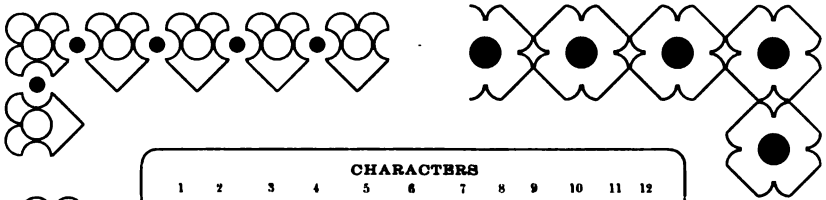
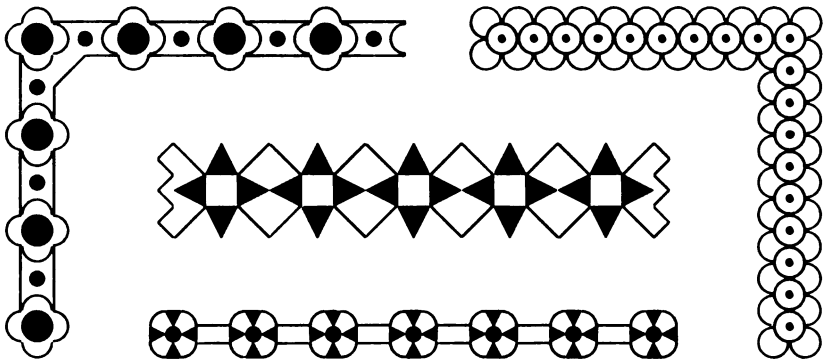

CHARACTERS

1	2	3	4	5	6	7	8	9	10	11	12

PER FONT \$3 00

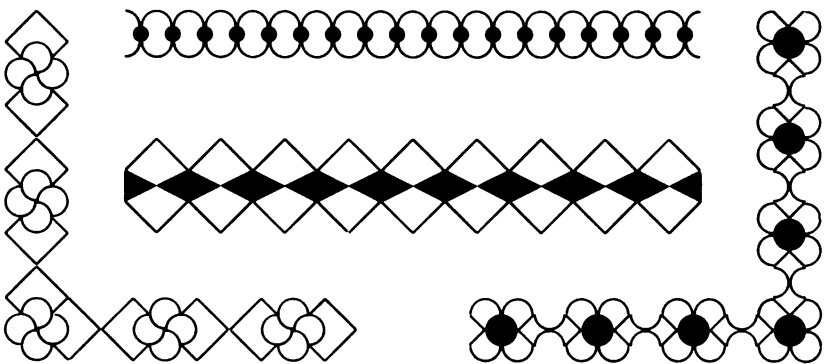
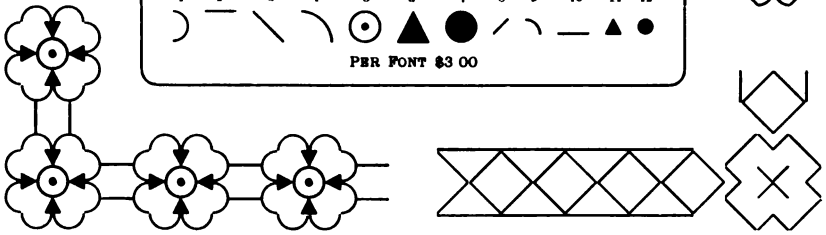

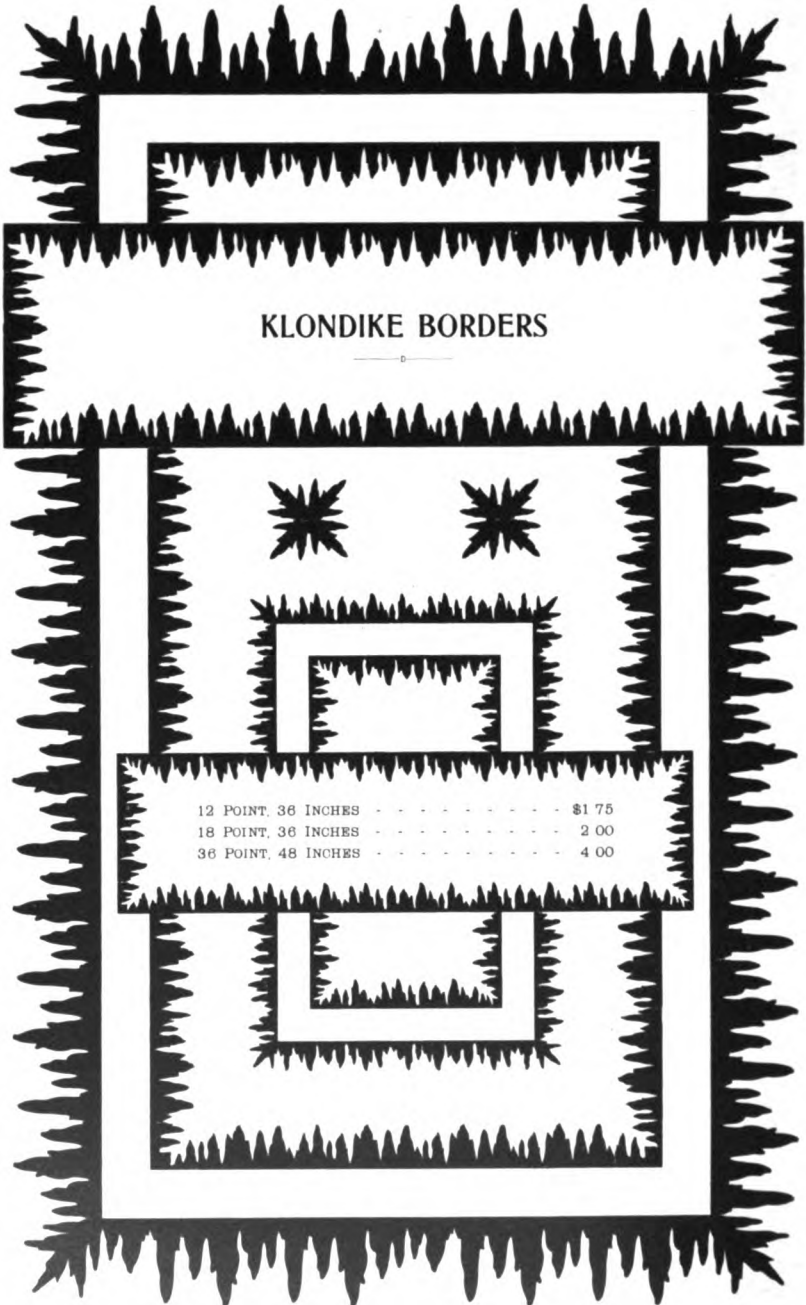

FLAG BORDERS

36 POINT NO 1 FOR ONE COLOR
36 POINT NO 2 FOR TWO COLORS

18 INCHES \$2 25
18 INCHES \$4 50



24 POINT NO 1 FOR ONE COLOR
24 POINT NO 2 FOR TWO COLORS

60 INCHES \$4 40
30 INCHES \$4 40



18 POINT NO 1 FOR ONE COLOR
18 POINT NO 2 FOR TWO COLORS

60 INCHES \$3 35
30 INCHES \$3 35



12 POINT NO 1 FOR ONE COLOR
12 POINT NO 2 FOR TWO COLORS

72 INCHES \$3 50
36 INCHES \$3 50



18 POINT MYRTLE BORDER

2

3

4

6

5

1

36 INCHES \$2 00

Each font contains 30 running inches, made up of 8 pieces of No. 1, 12 pieces of No. 2, 6 pieces of No. 3, 6 pieces of No. 4, 48 pieces (24 running inches) of No. 5, and 4 pieces of No. 6

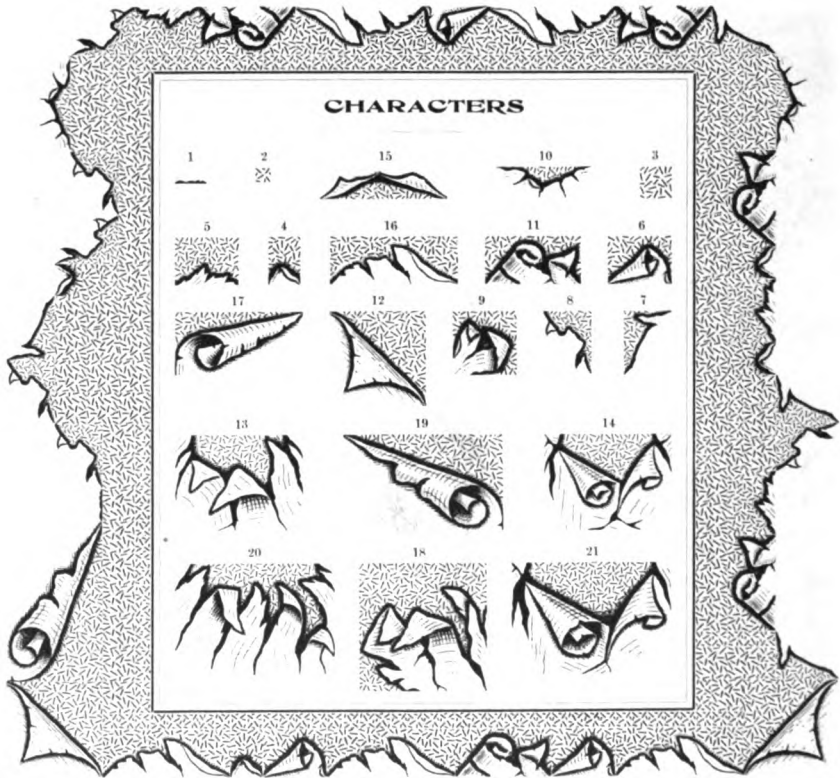

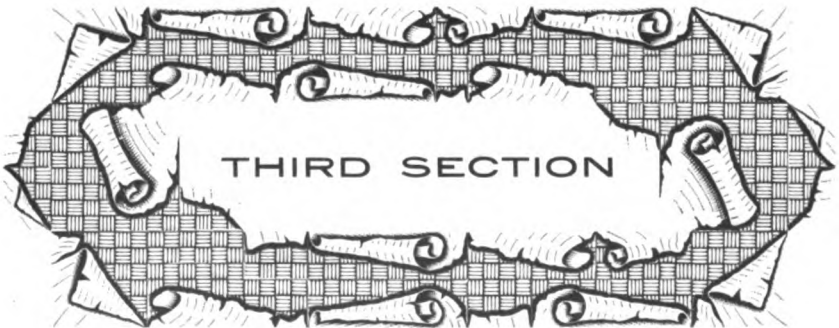
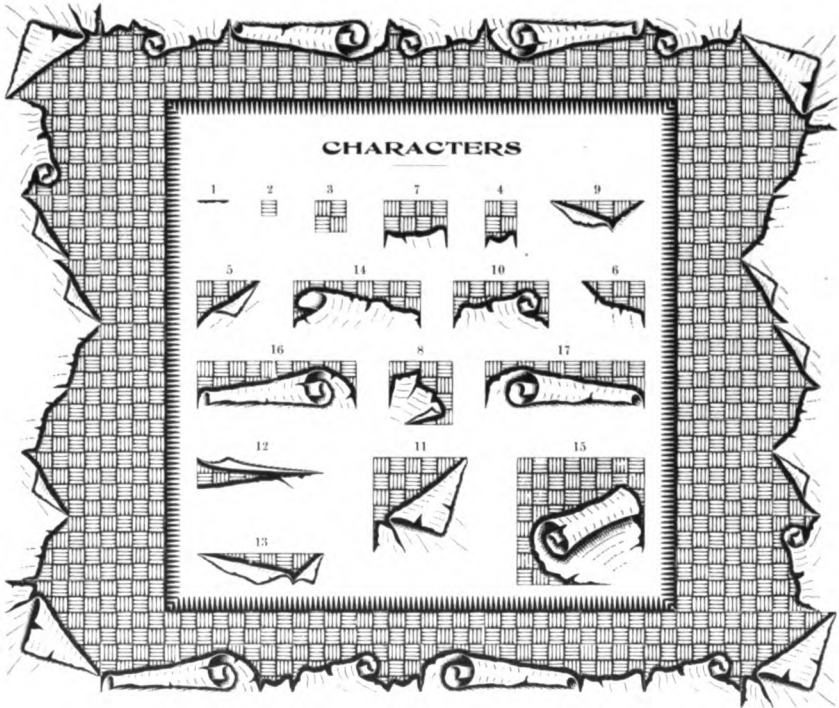
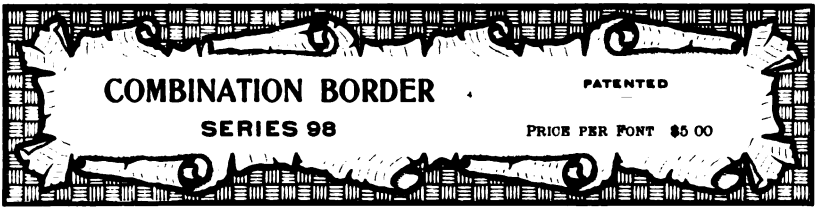

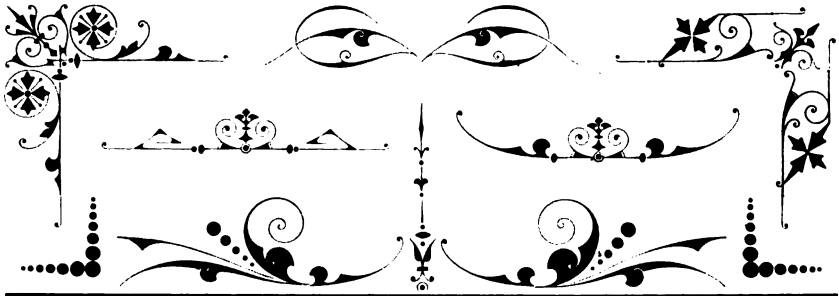

COMBINATION ORNAMENTS SERIES K

PRICE PER FONT \$4 50

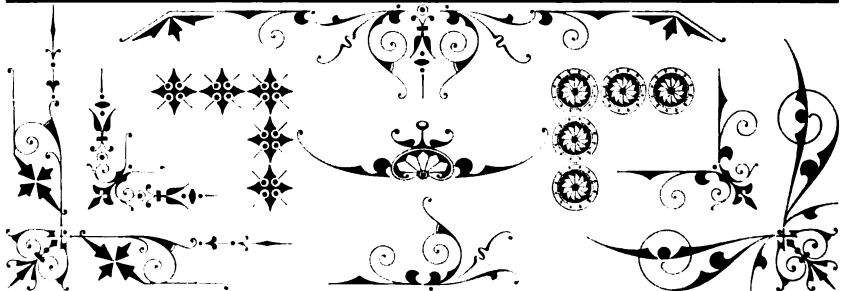
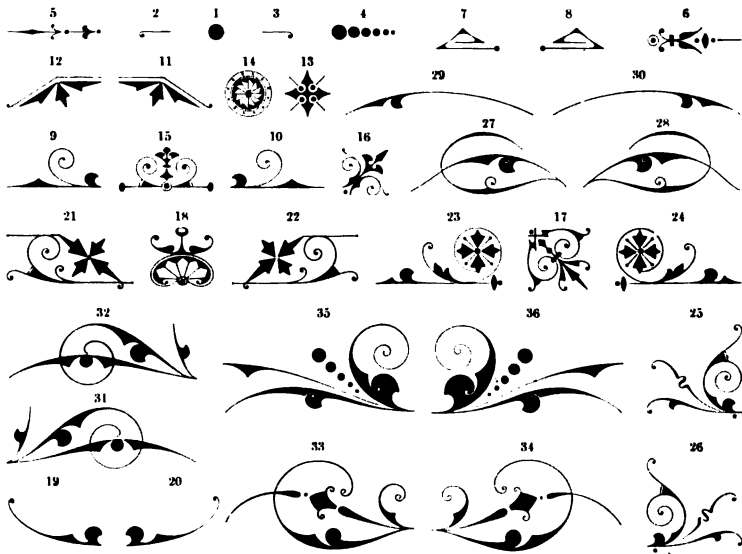

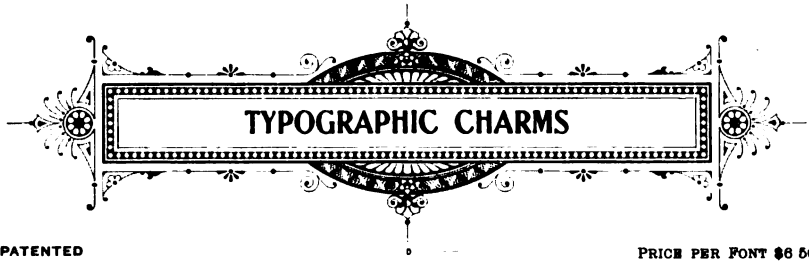

PATENTED

PRICE PER FONT \$6 50

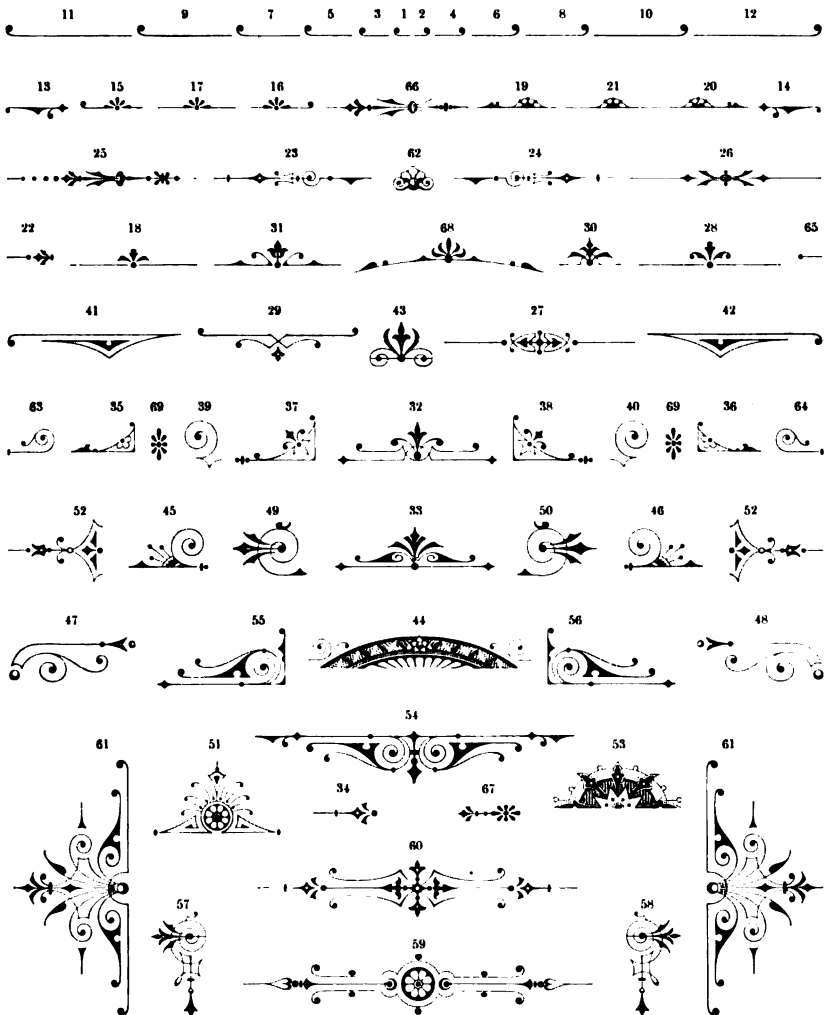

LAUREL WREATHS

Prices are net

No 8 \$1 00

No 17 \$1 00

MORTISED

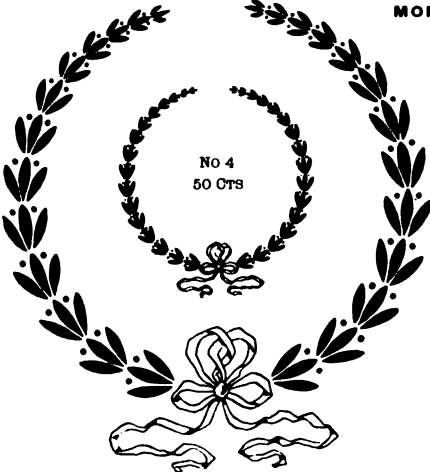

No 11 30 Cts

No 9 \$1 25

No 2 30 Cts

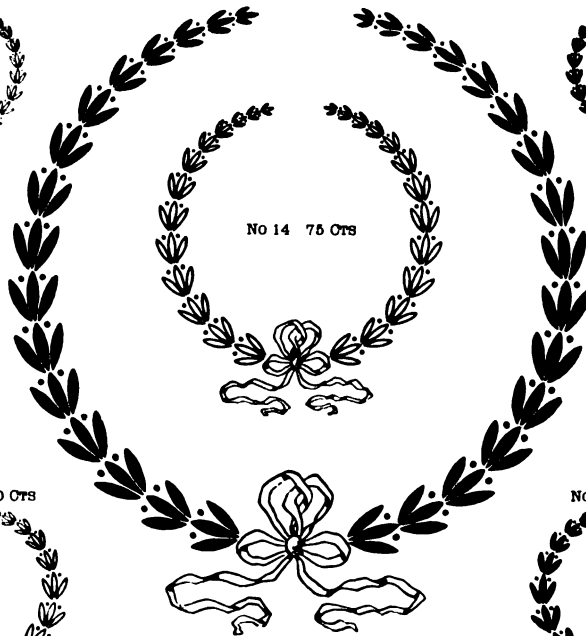

No 10 20 Cts

No 1 20 Cts



No 12 50 Cts

No 3 50 Cts



SOLID METAL ELECTROTYPES

MURAL ORNAMENTS

300A. 15 cts.



All characters except 292A put up in sets of four at 50 cents per set.
Characters Nos. 291A and 292A may be used for two-color initials.

295A. 15 cts.



317A. 15 cts.



305A. 15 cts.

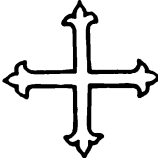

306A. 15 cts.

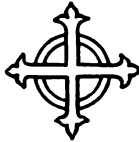

307A. 15 cts.

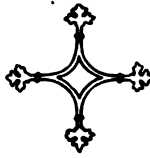

314A. 15 cts.

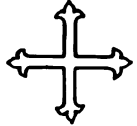

316A. 15 cts.



315A. 15 cts.

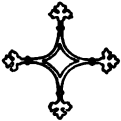

294A. 15 cts.



290A. 15 cts.



301A. 15 cts.



310A. 15 cts.



MARGIN ORNAMENTS

SERIES 1



SERIES NO 1 PER FONT \$1 26
SERIES NO 2 PER FONT \$1 00

SERIES 2

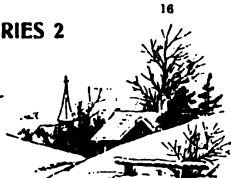
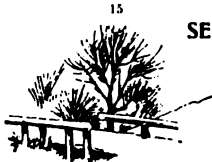

291A. 15 cts.



292A. 30 cts.



304A. 15 cts.



296A. 15 cts.



297A. 15 cts.



313A. 15 cts.



SLOCUM SEALS

PER FONT \$1 50



INK SPOTS

PER FONT \$1 25

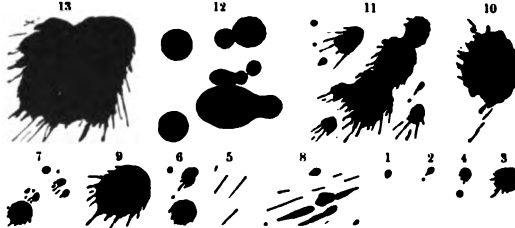

INSECTS

PER FONT \$1 25

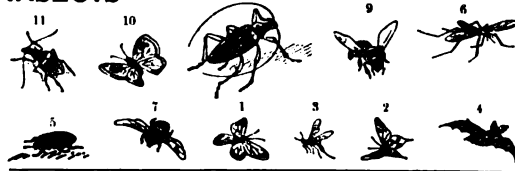

KLONDIKERS

CARD FONT \$2 00
JOB FONT \$3 50

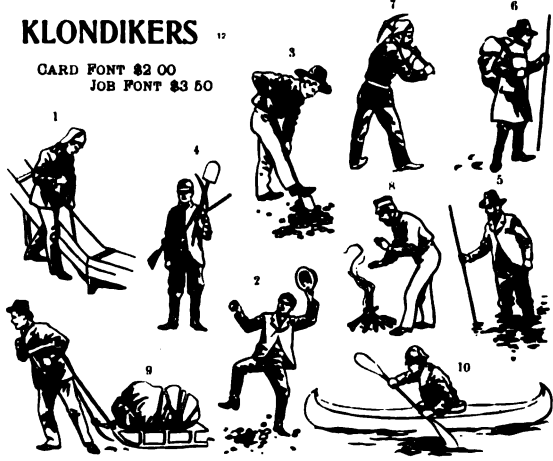

BOWLERS

PER FONT \$1 75

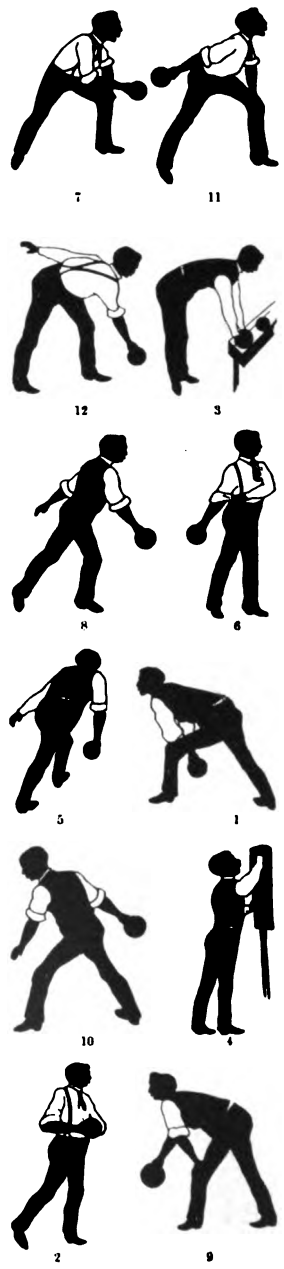

LARGE SCORCHERS

PER FONT

\$2 50



3



4



10



6



8



5



7



1



2



9

SMALL SCORCHERS

PER FONT

\$1 50



15



18



11



19



12



14



16



20



17



13

RIGS AND TRAPS

PER FONT

\$1 50



5



7



1



2



8



6



3



4

SPEAKERS 12

LARGE FONT \$2 50
SMALL FONT \$1 50

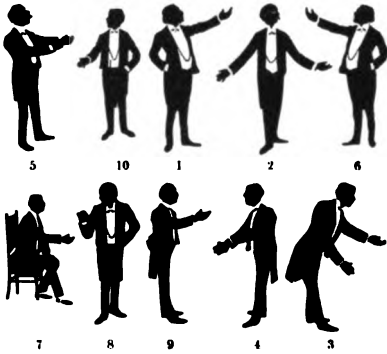

LISTENERS 12

PER FONT \$1 50

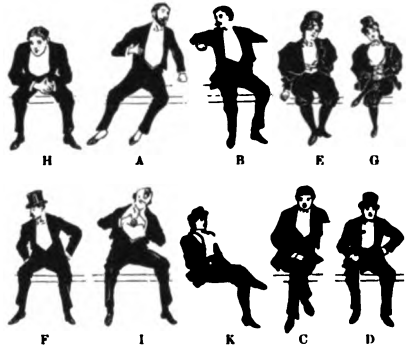

CAMPAIGNERS 1

PER FONT \$1 75

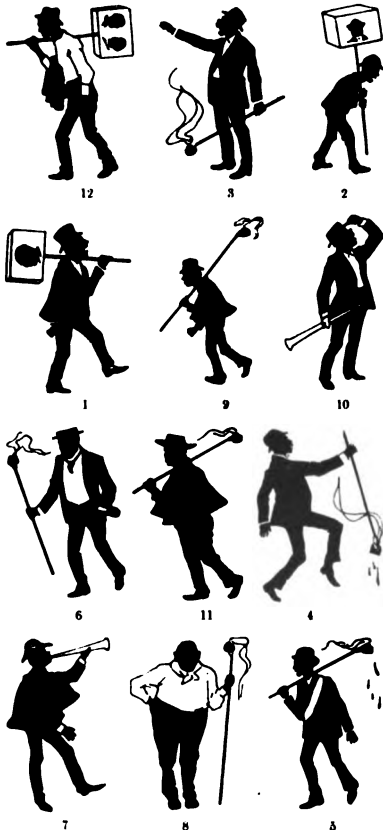

BALLET DANCERS 15

FONT \$2 00



LARGE LADY SPEAKERS

PER FONT

12

\$2 00



SMALL LADY SPEAKERS

PER FONT

12

\$1 25



SHOPPERS

12

PER FONT \$1 50

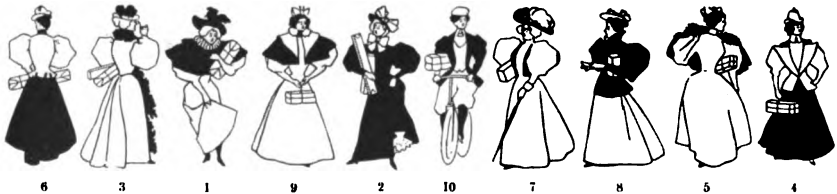

DOMESTICS

12

PER FONT \$1 50



PICK-UPS

PER FONT \$1 75



7 10 9 11



6 8 3 2



1 5 12 4

COPPERS

PER FONT \$1 50



7 6



5 10 2 8



9 3 1 4

DRUGGISTS

PER FONT \$1 50



2 10 7 6 9

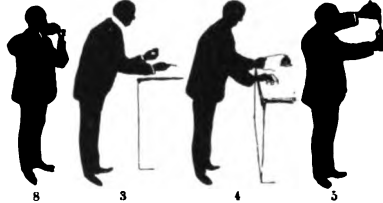

8 3 4 5

SILHOUETTES

PER FONT \$1 75



1



5 2 3 7



1 12 9 11



8 4 6 10

BASEBALL Series No 1

12
PER FONT \$1 50

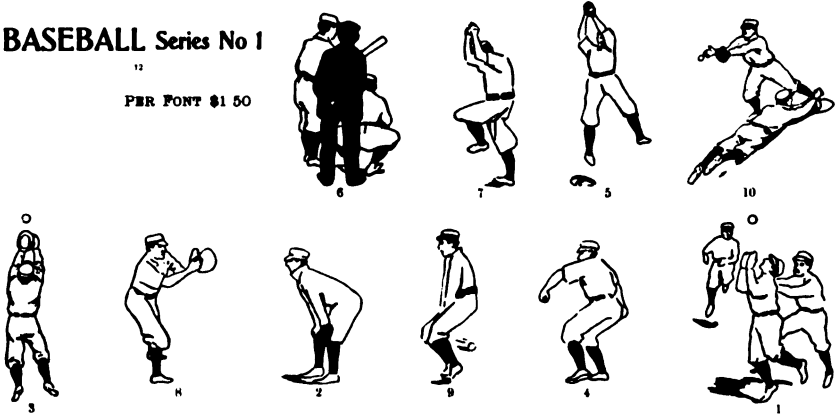

DELMONICO CHEFS AND WAITERS

15
PER FONT \$1 50

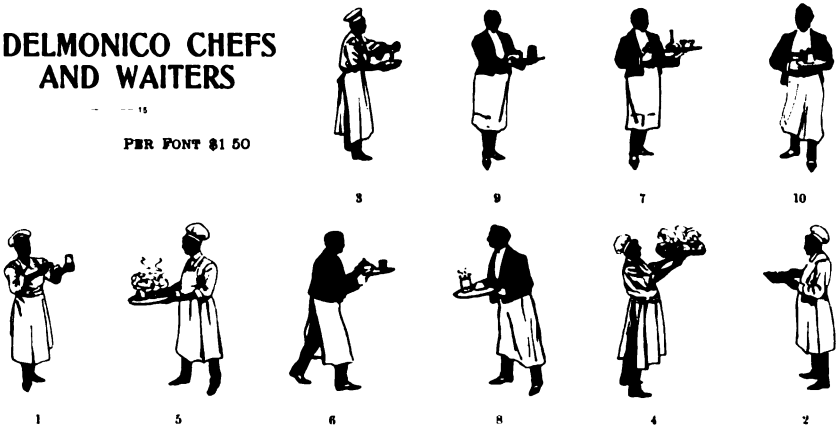

HOBOS

15
PER FONT \$1 50



KATE GREENAWAYS MIGNONNETTES

All cast in type mould



44. 30c.

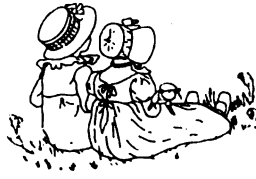

13. 30c.



34. 25c.



1. 25c.



53. 25c.



28. 25c.



43. 30c.



14. 30c.



45. 30c.



16. 30c.



51. 25c.



11. 25c.



38. 25c.



12. 25c.



54. 25c.



29. 25c.



52. 25c.



20. 25c.



46. 30c.



15. 30c.



49. 30c.



19. 30c.



93. 25c.



7. 25c.



56. 25c.



80. 25c.

KATE GREENAWAYS MIGNONNETTES

All cast in type mould



58. 25c.



27. 25c.



32. 25c.



6. 25c.



55. 25c.



22. 25c.



57. 25c.



10. 25c.



21. 25c.



50. 25c.



41. 25c.



23. 25c.



40. 25c.



9. 25c.



36. 25c.



3. 25c.



31. 25c.



5. 25c.



37. 25c.



2. 25c.



60. 25c.



24. 25c.



39. 25c.



26. 25c.



33. 25c.



14. 25c.



47. 30c.



17. 30c.



49. 30c.



18. 30c.



25. 25c.



59. 25c.



42. 25c.



4. 25c.

WAYSIDE ORNAMENTS

Cast in type mould

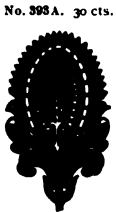

WAYSIDE EMBELLISHMENTS

Electrotyped

No. 4189C. 50c.
Per pair, 95c.



No. 4343A. 60 cts.



No. 4341A. 60 cts.



No. 4340A. 60 cts.



No. 4347A. \$1.00



No. 4342A. 50 cts.



No. 4397C. 50 cts.

SCHÖEFFER ORNAMENTS

Electrotypes

PER SET \$1 00

No. 4398C. 50 cts.

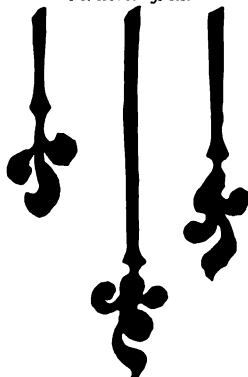

EMPIRE ORNAMENTS

36 POINT

PER FONT 75 CENTS



48 POINT

PER FONT \$1 00



JENSON EMBELLISHMENTS

No. 4268A. \$2.00

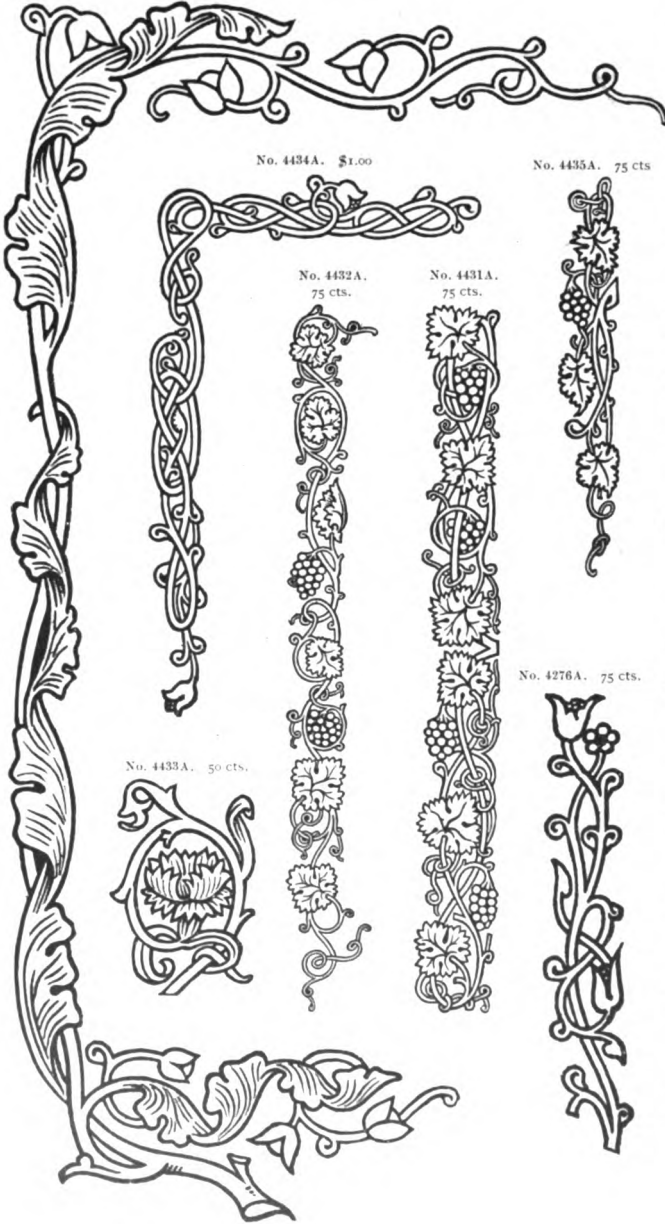

No. 4269A. \$7.00



No. 4434A. \$1.00



No. 4435A. 75 cts



No. 4432A. 75 cts.



No. 4431A. 75 cts.



No. 4433A. 50 cts.



No. 4276A. 75 cts.



JENSON EMBELLISHMENTS

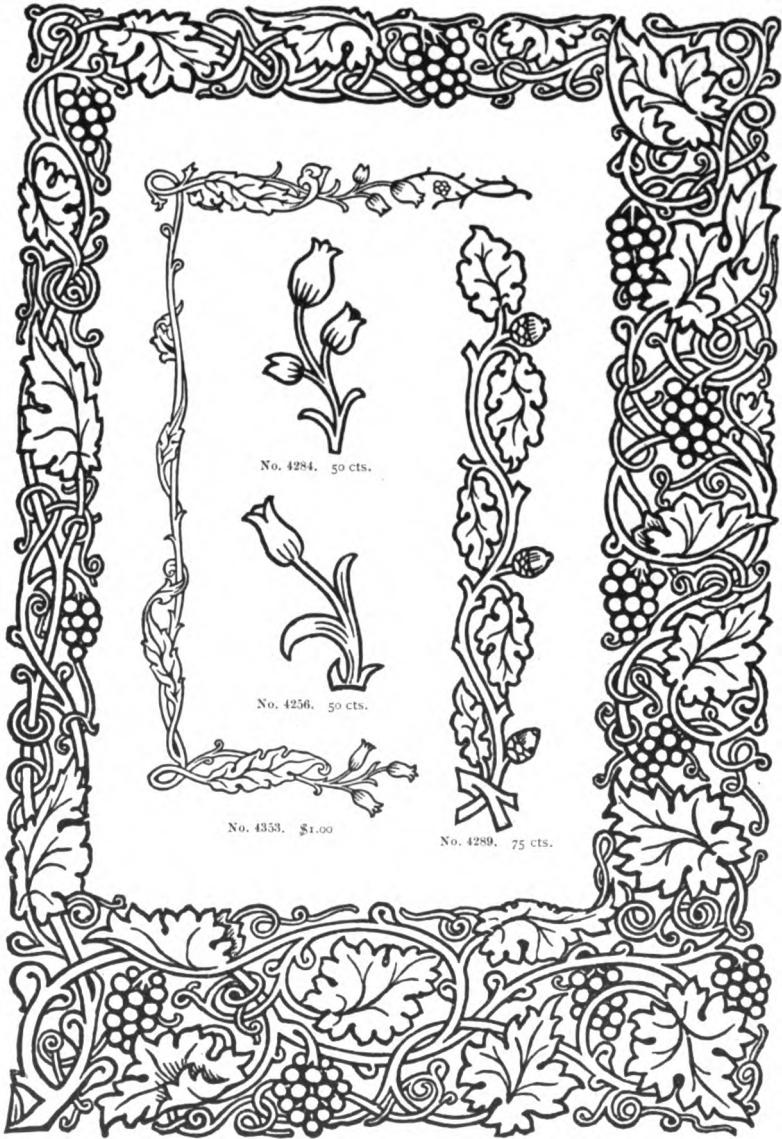

No. 4284. 50 cts.

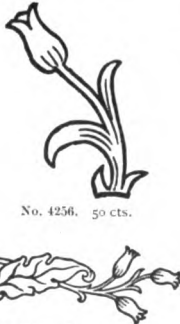

No. 4256. 50 cts.



No. 4353. \$1.00



No. 4289. 75 cts.

No. 4441. \$2.25

JENSON EMBELLISHMENTS



No. 4294. 75 cts.

No. 4257. 75 cts.

No. 4440. \$1.75



No. 4258. \$1.00



No. 4243. \$1.00



JENSON EMBELLISHMENTS



No. 4438. 75 cts.



No. 4295. \$1.00



No. 4439. \$1.00



No. 4264. \$2.00

JENSON EMBELLISHMENTS



No. 4288. \$1.25



No. 4278. 75 cts.



No. 4261. \$1.00



No. 4437. \$1.00



No. 4258. \$1.00



No. 4277. \$1.25



No. 4436. 75 cts.

MISCELLANEOUS CAST CUTS



STATE SEALS

Designed and cut on wood by the American Type Founders Company. Each Seal is re-engraved when any change occurs, and Seals of all new States are admitted to the Union.

Border No. 2751C. (Center mortised to suit the Seal of any State.) \$1.75. With Seal, \$2.50. Seal (only) No. 2776C. 75c. (Ohio)



No. 2779C. 75 cts. [Illinois]



No. 2773C. 75 cts. [Arkansas]



No. 2775C. 75 cts. [Kentucky]



No. 3700C. \$1.50 [Kansas]



No. 2235C. \$1.50 [Tennessee]



No. 2740C. 75 cts. [Missouri]



No. 2778C. 75 cts. [Indiana]



No. 2771C. 75 cts. [Louisiana]



We have Seals for all States, uniform with the two styles shown on this and the following page, at same prices.

No. 3128C. \$1.00 [Missouri]



No. 3124C. \$1.00 [Ohio]



No. 3126C. \$1.00 [Indiana]



No. 3132C. \$1.00 [West Virginia]



No. 3127C. \$1.00 [Illinois]



No. 3123C. \$1.00 [Kentucky]

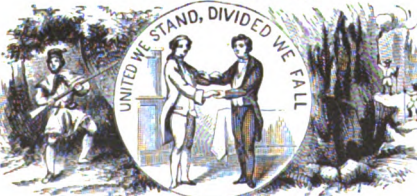

No. 3122C. \$1.00 [Tennessee]



No. 3118C. \$1.00 [Mississippi]



No. 3119C. \$1.00 [Louisiana]



No. 3120C. \$1.00 [Texas]



No. 3121C. \$1.00 [Arkansas]



No. 3137C. \$1.00 [Kansas]



We have Seals for all States, uniform with the styles shown on this and preceding page, and at same prices.

UNITED STATES EMBLEMS

Designed and engraved on wood by the American Type Founders Company

No. 2442C. 30 cts.



No. 3929C. Mortised. \$1.85

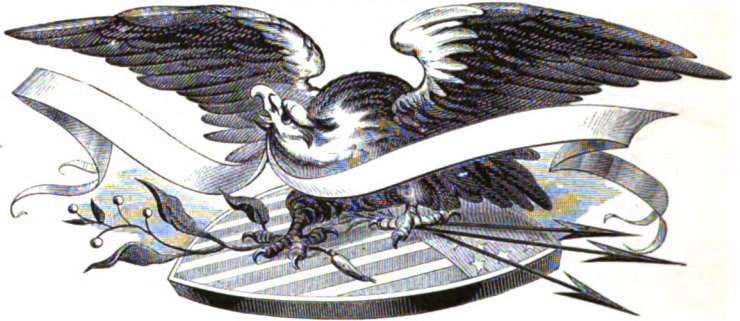

No. 857R. 30 cts.

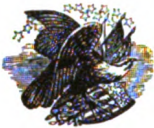

EAGLES FOR POSTERS

We have a number of mortised Eagle cuts, same style, but larger than No. 3929C. All are cut with the same degree of excellence.

- No. 2875C, 18x7 1/2 inches; three mortises for 48-point letter . . . \$15.00
- No. 2874C, 11x5 1/4 inches; two mortises for 36-point letter . . . 6.25
- No. 2873C, 8x4 inches; two mortises for 24-point letter . . . 5.00
- No. 2872C, 5 1/2 x 2 3/4 inches; two mortises for 18-point letter . . . 2.50

No. 2213 1/2 C. \$1.50



No. 2752C. 75 cts.



EAGLES FOR BORDERS

No. 2752C. 75 cts. This fits in Border No. 2751C. (\$1.75) with handsome effect. See page 690.

No. 2213 1/2 C. \$1.50. This fits in border No. 2213C. (\$2.50) 5 1/2 x 3 in., with handsome effect; similar in style to No. 2751C on page 690.

No. 3780C. \$1.50

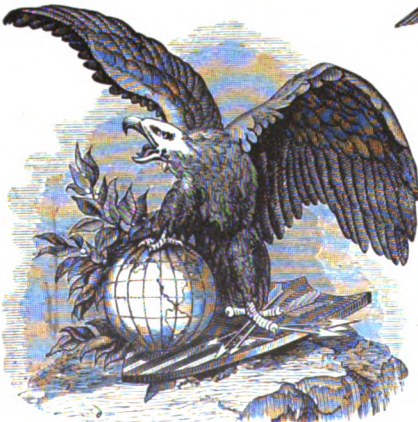

No. 514R. 25 cts.



No. 2385C. 75 cts.



No. 2471C. 50 cts.



No. 803E. 30 cts.



No. 2258C. Mortised. \$1.50



No. 3023C. 30 cts.



No. 3453C. \$1.25



No. 2727C. 25 cts.



No. 2443C. 30 cts.



No. 3781C. \$1.25



No. 3460C. 25 cts.



No. 2968C. 50 cts.



No. 2530C. 30 cts.



No. 3183C. \$1.50

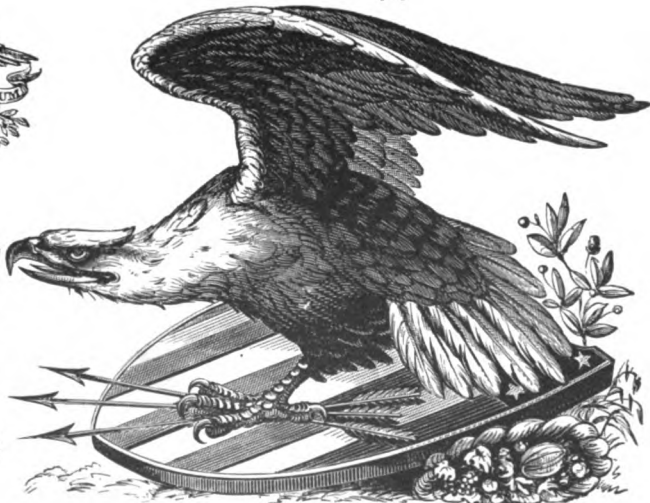

No. 3182C. 75 cts.



UNITED STATES FLAGS

All flags supplied for one or two colors. In ordering state if cuts are wanted for one or two colors.

OLD GLORY EMBOSSED SETS

A set includes plates for printing in three colors and an electro-embossing die. Flag designs are alike in each set.

- Per set
- Set A. Length (staff), 2 in.; width over all, 1 3/4 in. . . . \$3.00
 - Set B. Length (staff), 4 in.; width over all, 3 1/4 in. . . . 4.50
 - Set C. Length (staff), 5 1/4 in.; width over all, 4 1/2 in. . . . 6.00

Set A. \$3.00. (For Embossing.)



No. 5144C. \$1.50



These handsome flags were designed and engraved by the American Type Founders Company. This style is made in three sizes, for either one or two colors; the two smallest are shown on this page (No. 5142C, No. 5144C). Dimensions of largest size (No. 5127 1/2 C): length of staff, 5 inches; width over all, 4 inches.

OTHER SIZES: for dimensions see above.

- No. 5127 1/2 C. For one color \$2.25
- No. 5127 C. For two colors (same size as 5127 1/2 C) . . . 3.50
- No. 5145 C. For two colors (same size as 5144 C) . . . 2.50
- No. 5143 C. For two colors (same size as 5142 C) . . . 2.00

No. 5142C. \$1.25



A companion flag to No. 2712C is also made, same size and style, but with staff to the left. This is No. 2713C.

- No. 2712C. Right \$0.75
- For two colors 1.25
- No. 2713C. Left 0.75
- For two colors 1.25

No. 2712C. 75c.



No. 4100F. 25c.



No. 2969C. (Cast in type mould.) 30 cents each; \$2.50 per dozen. For two colors, 50 cents per set; \$4.50 per dozen.



For Two-Color Flags, printed in colors, see page 603

No. 3955C. 60 cts.



No. 3952C. \$1.00



No. 200B. 90 cts.



No. 4125C. 40 cts.



No. 3953C. 75 cts.

No. 193B. 45 cts.

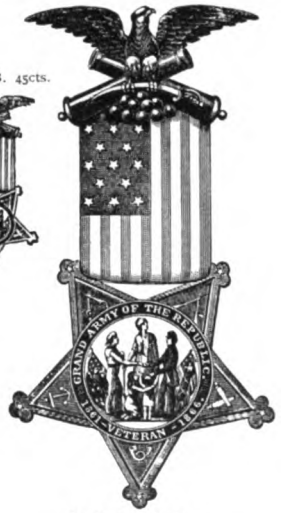

No. 2022E. \$1.00



No. 196B. 60 cts.



No. 201B. 75 cts.



No. 202B. 75 cts.



For four colors, \$2.50

No. 197B. 60 cts.



No. 198B. 60 cts.



No. 1109F. \$1.00



No. 5107C. \$1.50. [Cuba Libre.]



No. 5123C. 50 cts. [Bolivia.]



No. 3998C. 75 cts. [Brazil.]



OTHER SIZES:
 No. 5112C. 1 3/4 x 2 1/4 in. \$1.25
 No. 5114C. 1 3/4 x 2 in. 1.00
 No. 5111C. 1 1/2 x 1 3/4 in. 75 cts.

Coats-of-Arms of all South American Republics Supplied

OTHER SIZES:
 No. 4000C. 2 1/4 x 2 in. \$1.50
 No. 3999C. 1 3/4 x 1 3/8 in. 1.00

No. 5154C. \$1.00

This style of Cuban flags (5154C) is furnished in three sizes (right or left), for one or two colors. Sizes and prices given below.



OTHER SIZES:
 No. 5108C. 1 1/2 x 1 3/8 in. \$1.25 | No. 5109C. 1 1/8 in. sqr. \$0.50

No. 2559C. \$1.25. [Mexico.]



OTHER SIZE:
 No. 2567C. 3 x 3 1/4 in. \$2.50

No. 2554C. 60 cts. [Mexico.]



OTHER SIZE:
 No. 2561C. 2 1/2 x 2 1/2 in. \$1.85

No. 12134C. 35 cts.



No. 2546C. \$1.00



No. 12137C. 40 cts.



No. 12830C. 40 cts.



	ONE COLOR	TWO COLORS
No. 5156C. Length (staff), 3 7/8 in.; width over all, 3 1/2 in. (Right)	\$1.25	\$2.00
No. 5155C. Length (staff), 3 7/8 in.; width over all, 3 1/2 in. (Left)	1.25	2.00
No. 5154C. (Right; same as shown)	1.00	1.60
No. 5153C. (Left; same as shown)	1.00	1.60
No. 5152C. Length (staff), 2 in.; width over all, 1 3/4 in. (Right)	0.90	1.40
No. 5151C. Length (staff), 2 in.; width over all, 1 3/4 in. (Left)	0.90	1.40

No. 2435C. \$1.50



No. 2904C. 50 cts.



No. 2708C. \$1.50

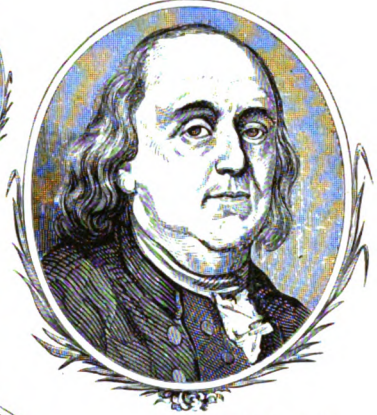

No. 4149C. 35c.



No. 3778C. \$1.50

No. 3938C. \$1.25



No. 4095C. 40 cts.



No. 3779C. \$1.00



No. 4141C. 75 cts.

No. 161B. \$1.50



No. 3818C. \$1.50

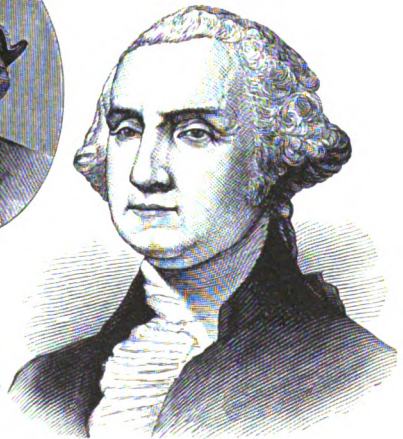

No. 4148C. 40 cts.



SOCIETY EMBLEMS

No. 216B. 90 cts.



For two colors, \$1.50

No. 226B. 75 cts.

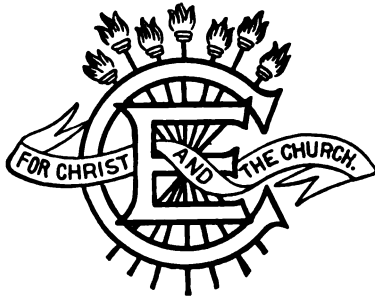

No. 217B. 35 cts.



No. 220B. 35 cts.



No. 239B. 90 cts.



No. 215B. 75 cts.



No. 229B. 50 cts.



No. 223B. 50 cts.



No. 4152C. 40 cts.



No. 4153C. 30 cts.



No. 214B. 60 cts.



No. 227B. 50 cts.



No. 213B. 75 cts.



No. 233B. 50 cts.



No. 230B. 60 cts.



No. 228B. 75 cts.



No. 221B. 40 cts.



No. 225. 60 cts.



No. 233B. 60 cts.

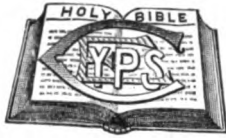

No. 224B. 60 cts.



No. 244B. 75 cts.



No. 222B. 40 cts.



No. 231B. \$1.00

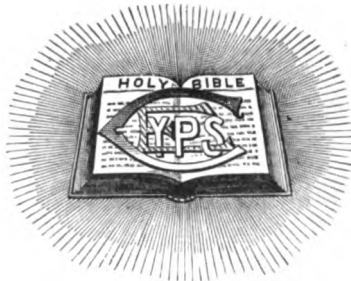

No. 242B. 40 cts.



No. 278B. 40 cts.



No. 240B. 40 cts.



No. 243B. 35 cts.



No. 241B. 40 cts.



No. 248B. 40 cts.



No. 236B. 40 cts.



No. 235B. 40 cts.



No. 234B. 75 cts.



No. 239B. 75 cts.



No. 237B. 70 cts.



No. 2077E. 75c.



No. 2309 1/2 C. 38c.



No. 3170C. 40c.



No. 3166C. 40c.



No. 3361C. 50c.



No. 2135C. 25c.



No. 3172C. 30c.



No. 3030C. 30c.



No. 420C. 30c.



No. 3171C. 30c.



No. 3435C. 50c.



No. 3169C. 80c.

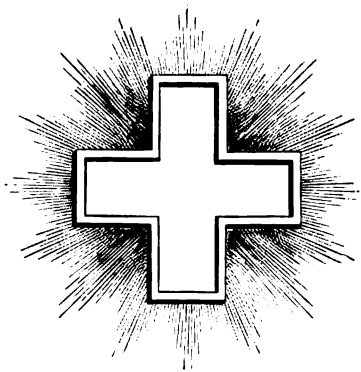

No. 3166C. 40c.

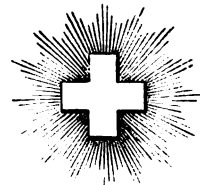

No. 1225C. 25c.



No. 3653C. 35c.



No. 3359C. 25c.



No. 3635C. 30c.



No. 3372C. 35c.



No. 2998C. 25c.



No. 2971C. 25c.



No. 3002 1/2 C. 15c.



No. 236C. 8c.



No. 3279C. 50c.



No. 3407C. 60c.



No. 3031C. 30c.



No. 3362C. 30c.



No. 2000E. 35c.



No. 3355C. 35c.



No. 3165C. 40c.



No. 2079E. 75c.



No. 3167C. 40c.



No. 3364C. 30c.



No. 3357C. 35c.



No. 3365C. 35c.



No. 3360C. \$2.00

No. 3394C. \$2.00

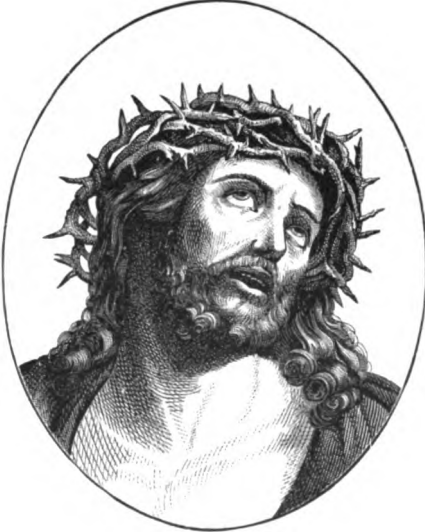

No. 2081E. 70c.



No. 2078E. \$1.25



No. 3356C. 40c.



No. 3359C. 25c.



No. 3363C. 30c.



No. 3383C. 35c.



No. 3354C. 35c.



No. 3063A. \$1.00



No. 3079A. \$1.00



No. 108B. 75 cts.

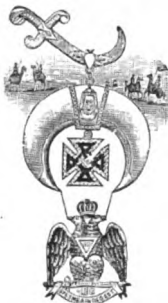

No. 4140C. \$1.00

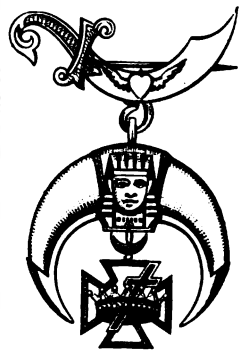

No. 3066A. 75 cts.



No. 3044A. 75 cts.



No. 3327A. 75 cts.



No. 2432C. 50 cts.



No. 3078A. 75 cts.



No. 1850A. 40 cts.



No. 3027A. 30c.



No. 3059A. 75 cts.



No. 3079A. 50 cts.



No. 172B. 25c.



No. 3109A. 35c.



No. 170B. 40c.



No. 3653C. 35 cts.



No. 166B. 30c.



No. 3323A. 60 cts.



No. 3077A. 40 cts.



No. 3401C. 50 cts.



No. 3402C. 50 cts.



No. 3403C. 50 cts.



No. 3404C. 50 cts.



No. 3400C. 50 cts.



No. 3399C. 50 cts.



No. 3970C. 60 cts.



No. 3455C. 50 cts.



No. 3072A. \$1.00



No. 3682C. 50 cts.



No. 3069A. \$1.00



No. 3321A. \$1.00



No. 81B. 15c. No. 83B. 15c. No. 79B. 15c.



No. 3454C. \$1.00

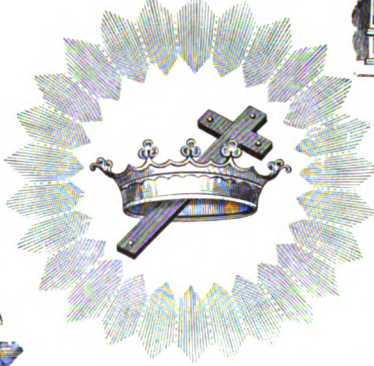

No. 77B. 15c. No. 82B. 15c. No. 80B. 15c.

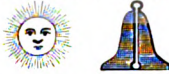

No. 164B. 50 cts.



No. 2241A. 75 cts.



For three colors, \$1.25

No. 2434A. Mortised. \$1.00



No. 3654C. 40 cts.



No. 3024A. 30c.



No. 1290F. 75 cts.

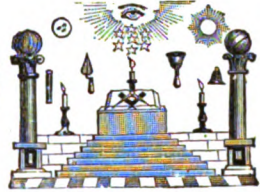

No. 2431C. \$1.00

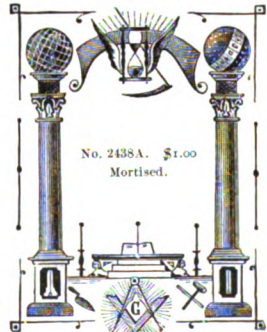
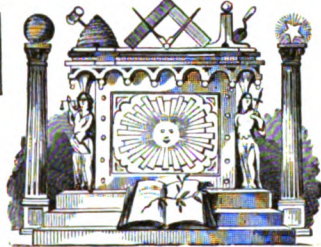

No. 2438A. \$1.00
Mortised.

No. 163B. 75 cts.



For three colors, \$1.50

No. 2970C. 50 cts.



No. 3395C. \$1.00



No. 3396C. \$1.00



No. 3398C. \$1.00

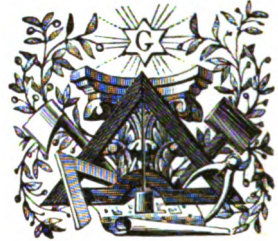

No. 3394C. \$1.00



No. 3393C. \$1.00



No. 3397C. \$1.00



No. 2013E. \$1.00



No. 2754A. 50 cts.



No. 3055A. \$1.25



No. 1224F. 75 cts.



No. 3081A. 75 cts.



No. 916E. 30 cts.



No. 3061A. 50 cts.



No. 3033A. 75 cts.

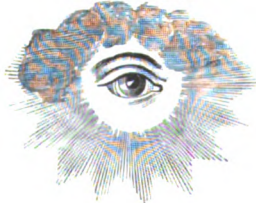

No. 3325A. 75 cts.

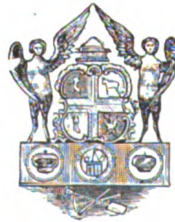

No. 3050A. 75 cts.



No. 3064A. 75 cts.



No. 3122A. \$1.00



No. 3119A. 75 cts.



No. 174B. \$1.00



No. 176B. \$1.00



No. 3119A. 75 cts.

For two colors, \$1.50

For two colors, \$1.50

No. 3121A \$1.00



No. 3111A. 60 cts.



No. 3123A. \$1.00



No. 175B. \$1.00



No. 2015E. 75 cts.



No. 3104A. 40 cts.



No. 1116F. 40 cts.



No. 179B. 25 cts.



No. 173B. 25 cts.



No. 3110A. 40 cts.



No. 177B. 35 cts.



No. 190B. 30 cts.



No. 2766A. 90 cts.

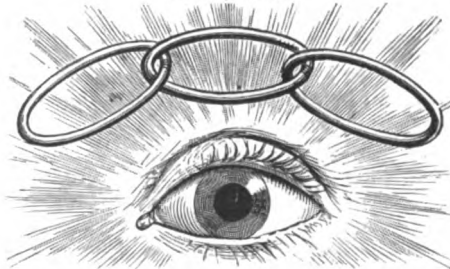

No. 181B. 60 cts.



No. 2287A. 50 cts.



No. 1232F. 60 cts.



No. 1275F. \$1.00



No. 3126A. 60 cts.



No. 3418C. 60 cts.



No. 3620C. \$1.00



No. 186B. 75 cts.

No. 1329F. 50c.



No. 3417C. 30c.



No. 3790C. \$1.00

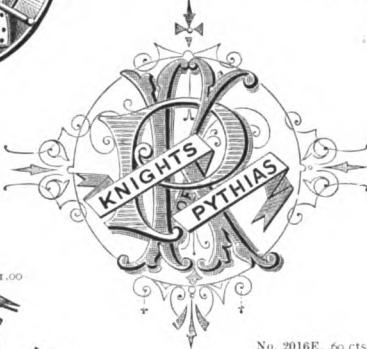

No. 1211F. 50 cts.



No. 185B. \$1.00



No. 187B. \$1.00



No. 2016E. 60 cts.



No. 3662C. 40 cts.



No. 188B. 75 cts.

No. 3683C. 50 cts.



No. 3419C. 75 cts.



For three colors, \$2.00

No. 3089A. 75 cts.



No. 3135A. 40c.



No. 1262F. 50 cts.



No. 3136A. 60 cts.



No. 267B. 75 cts.



No. 1266F. \$1.00

Imp. O.R.M.

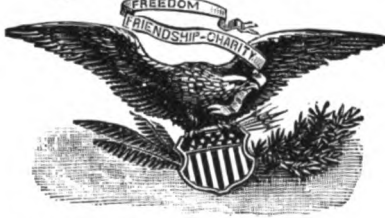

No. 1264F. 75 cts.



No. 183B. 40 cts.



No. 2820A. 50c.



No. 3657C. 40c.



No. 184B. 90 cts.



No. 3658C. 35c.



No. 3152A. \$1.00

No. 3157A. 60 cts.



No. 3129A. 60 cts.]]



No. 3092A. 50 cts.



No. 192B. 75 cts.



No. 3153A. \$1.00



No. 3972C. 60 cts.



No. 1361F. 50 cts.



For four colors, \$2.00

Mortised for name of Lodge

No. 190B. \$1.25



No. 4041A. 55 cts.



No. 1238F. \$1.25



No. 1331F. 50 cts.



No. 3996C. 75 cts.



No. 3191A. 75 cts.

No. 191B. 50 cts.



No. 3186A. \$1.00



No. 2018E. \$1.00



No. 3169A. \$1.00



No. 257B. 60 cts.



No. 3171A. \$1.00



No. 254B. \$1.00



No. 1336F. 50 cts.



No. 4123C. 75 cts.

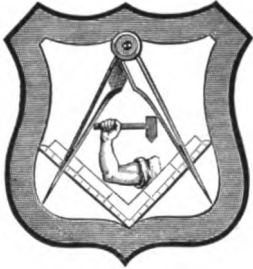

No. 903E. 30 cts.



No. 3190A. \$1.25



No. 3661C. 30 cts.



No. 3185A. \$1.00



No. 3181A. 75 cts.



No. 4122C. 40 cts.



No. 4144C. 60 cts.



No. 1204F. \$1.00



No. 3146A. 60 cts.



No. 3184A. 30c.



No. 3132A. 50 cts.



No. 3189A. 60 cts.



No. 3133A. 60 cts.

No. 1207F. 50 cts.



No. 247B. 50 cts.



No. 246B. 40 cts.



No. 4124C. \$1.00

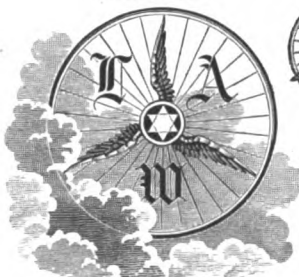

No. 4121C. 40 cts.



No. 248B. 75 cts.





No. 3490C. Mortised. \$1.75

No. 3685C. 50 cts.



No. 3149A. 75 cts.



No. 3154A. \$1.00



No. 2048C. 75 cts.



No. 3147A. 50 cts



No. 2319 1/4 A. 75 cts

No. 3159 1/4 A. 50 cts.



No. 3148A. 50 cts.

No. 3659C. 40 cts.



No. 1274E. 40 cts.



No. 256B. 75 cts.



No. 3142A. 50 cts.



No. 3150A. 60 cts.



No. 2023E. 75 cts.



No. 3166A. 75 cts.

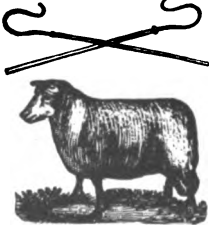

No. 2067E. 75 cts.



No. 1324F. 60 cts.



No. 2857A. \$1.00

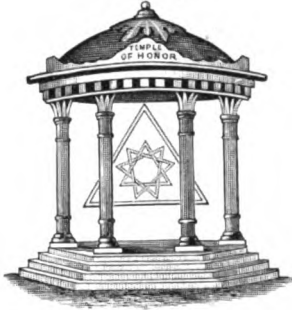

No. 2868B. \$1.15



No. 1381F. 40 cts.

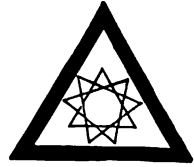

No. 3141A. 50 cts.



No. 3176A. 50 cts.



No. 902E. 30 cts.



No. 4110F. 25c.



No. 1301F. 40 cts.

No. 260B. 75 cts.

No. 2024F. 50c.



No. 3138A. 50 cts.



No. 261B. 40 cts.



No. 2007E. \$1.00

No. 2011E. \$1.00



No. 3196A. \$1.25



No. 259B. \$1.00

No. 3155A. \$1.00



No. 3167A. \$1.00

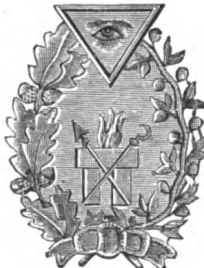

No. 255B. Mortised. \$1.50



No. 1258F. 60 cts.



No. 1208F. 60 cts.



No. 1341E. 50 cts.

No. 2026F. 75 cts.



No. 3161A. 75 cts.

No. 2025E. 50 cts.



No. 3159 A. 50 cts.



No. 1324F. \$1.00



No. 1344F. 75 cts.

No. 1277F. 50 cts.



No. 1268F. 90 cts.



No. 7049H. \$1.50



No. 7048H. 75 cts.



No. 2028E. 75 cts.



No. 253B. 50 cts.

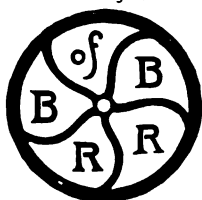

No. 252B. 50 cts.



No. 251B. 50 cts.



No. 250B. 50 cts.



No. 266B. 50 cts.



No. 4120C. 75 cts.



No. 249B. 90 cts.

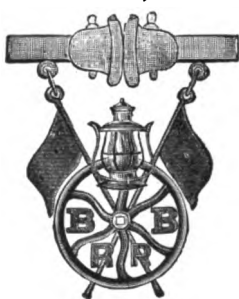

No. 3200A. \$1.00



No. 2439C. \$1.00



No. 3201A. 75 cts.



No. 3198A. \$1.00



No. 2943C. 15 cts.



No. 264B. 40 cts.



No. 3293C. 30 cts.



No. 2014A. 40 cts.



No. 828A. \$1.00

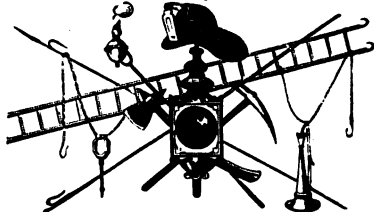

No. 2419C. 40 cts.



No. 2105A. 50 cts.



No. 4185C. 75 cts.



No. 204B. 90 cts.



No. 3177A. \$1.25



No. 205B. 75 cts.



No. 234A. 40 cts.



No. 987A. 60 cts.



No. 3172A. 50 cts.



No. 203B. \$1.00



No. 210B. 75 cts.



No. 209B. 50 cts.



No. 3171C. 35 cts.



No. 3174A. 60 cts.



No. 2089A. 30c.



No. 3173A. 75 cts.



No. 3178A. 75 cts.



No. 3175A. 40 cts.



No. 307B. 90 cts.



No. 3163A. \$1.25

No. 206B. 60 cts.



No. 3160A. 40 cts.



No. 3144A. 60 cts.



No. 211B. 75 cts.



No. 208B. 40 cts.



No. 3145A. 30c.



No. 3143A. 60 cts.



No. 212B. 90 cts.



No. 1273F. 50 cts.



No. 3170A. 60 cts.

No. 262B. 75 cts.



No. 263B. 75 cts.



No. 1285F. 60 cts.



No. 3189A. 50 cts.



No. 258B. 90 cts.

No. 3194A. \$1.25



No. 12,167C. 30 cts.



No. 4362A. 60 cts.
Sons of the Revolution.



No. 4395A. 60 cts.
Sons of American Revolution



No. 4368A. 60 cts.
Military Order of Loyal Legion of U. S.



No. 4388A. 75 cts.
Naval Order of U. S.



No. 4364A. 60 cts.
Daughters of the Revolution.



No. 4361A. 60 cts.



No. 4366A. 60 cts.
Society of Colonial Wars.



No. 4398A. 60 cts.
Military Order of Foreign Wars of U. S.



No. 4363A. 60 cts.
Daughters of American Revolution.



No. 4389A. 75 cts.



No. 4396A. 60 cts.



No. 4394A. 60 cts.



No. 4398A. 65 cts.
Medal of Honor Legion.



No. 3131A. 35 cts.
Legion of Honor.



No. 1343F. 75 cts.



No. 4397A. 75 cts.



No. 4365A. 65 cts.
U. S. Daughters War of 1812.



No. 2029E. \$1.00



No. 199B. \$1.00

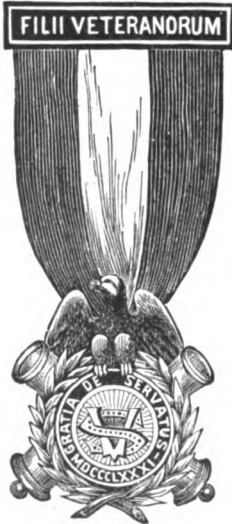

No. 4392A. 60 cts.
Society of Wars of 1812.



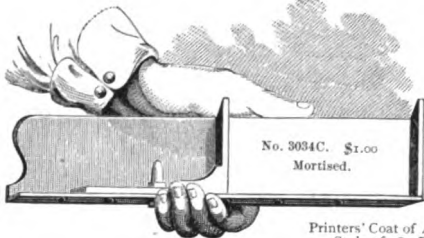

No. 1874D. 75 cts.



No. 3280C. 40 cts.



No. 3273C. \$1.00



No. 3271C. 60 cts.



Printers' Coat of Arms.
Style of 1873D.
We have three other sizes:

- No. 1877D, 3 1/4 ins., \$2.00
 - No. 1876D, 2 1/2 ins., 1.50
 - No. 1872D, 7/8 in., .50
- Cuts 1874D, 1875D, 1876D, 1877D also furnished to work in six colors; 1873D for four colors; 1872D for three colors; 1871D for two colors.

No. 1873D. 60 cts.



No. 1870D. 25c.



No. 1871D. 35c.



No. 3290C. 50 cts.



No. 3281C. 60 cts.



No. 1875D. \$1.00



No. 3272C. 75 cts.



No. 3143C. \$1.00



No. 3153C. 80 cts.



No. 3795C. 75 cts.



No. 4096C. \$1.25

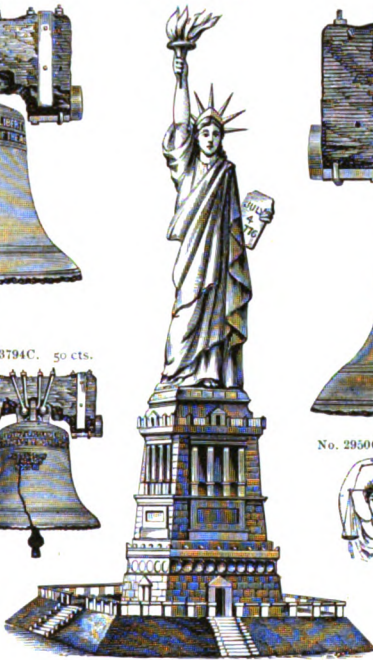

No. 3796C. \$1.25



No. 2016C. 25c.



No. 3794C. 50 cts.



No. 2950C. 25 cts.



No. 2941C. 25c.



No. 3142C. \$1.25



No. 2408C. \$1.00



No. 3476C. 75 cts.



No. 2942C. 15 cts.



No. 2948C. 25 cts.



No. 2441C. \$1.00

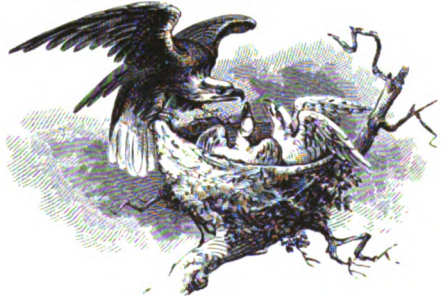

No. 3438C. 40 cts.



No. 3944C. 25 cents each; \$2.00 per dozen.



No. 3051C. 75 cts.

No. 3289C. 30 cts.

No. 12,180C. 50 cts.

No. 3146C. 75 cts.



No. 3445C. 60 cts.



No. 2395C. 30 cts.



No. 2317C. 40 cts.



No. 2926C. Mortised. \$1.50



No. 2197C. \$1.00



No. 2951C. 15c.



No. 3409C. \$1.00



No. 3948C. Mortised. 75 cts.



No. 3175C. 80 cts.

No. 2937C. 50 cts.



No. 3949C. Mortised. 50 cts.

No. 2887A. 30c.



No. 2040E. 25c.



No. 3062C. 30c.



No. 2034E. 25c.



No. 2033E. \$1.25



No. 2039E. 35c.



No. 2034E. 75 cts.



No. 3954C. 75 cts.



No. 2974C. 50 cts.



No. 2036E. 50 cts.



No. 2037E. 50 cts.



No. 2044K. 75 cts.

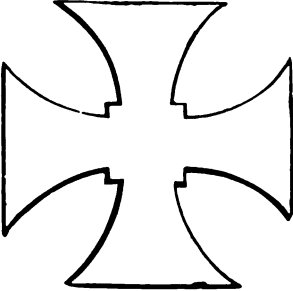

No. 2042E. 45 cts.



No. 1824D. 75 cts.



No. 1744D. 35 cts.



No. 132B. 30 cts.



No. 3426C. \$1.00.



No. 2477C. \$1.50



INDEX CORNERS

COPYRIGHTED

No. 3986C.



No. 3987C.



No. 3991C.



No. 3990C.



No. 3989C.



No. 3988C.



No. 3992C.

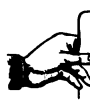

No. 3993C.



No. 4037C.



No. 4043C.



No. 4044C.



No. 4038C.



No. 4039C.

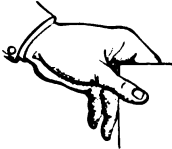

No. 4041C.

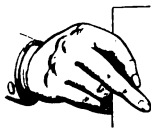

No. 4042C.

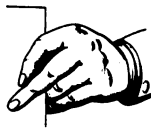

No. 4040C.



No. 4047C.



No. 4053C.



No. 4048C.

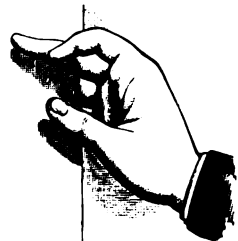

No. 4046C.



No. 4051C.



No. 4052C.

No. 4045C.



No. 4049C.



No. 4050C.



PRICES

Nos. 3986C to 3993C, set of eight	\$1.75
Single Corner	.25
Nos. 4037C to 4044C, set of eight	2.50
Single Corner	.35
Nos. 4045C to 4052C, set of eight	3.50
Single Corner	.50
No. 4053C	.50

ELECTROTYPED ON SOLID METAL BODIES

No. 4201C. 50 cts.



No. 4211C. 50 cts.



No. 4209C. 50 cts.



No. 4205C. 50 cts.



No. 3968C. 90 cts.



No. 3958C. 90 cts.



ELECTROTYPED OUTLINE FIGURES

FIRST SERIES. 30 cts. each

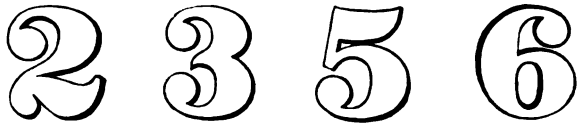

SECOND SERIES. 40 cts. each



THIRD SERIES. 40 cts. each

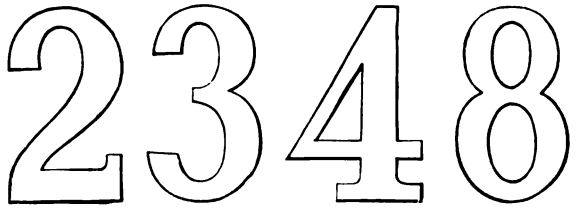

FOURTH SERIES. 50 cts. each

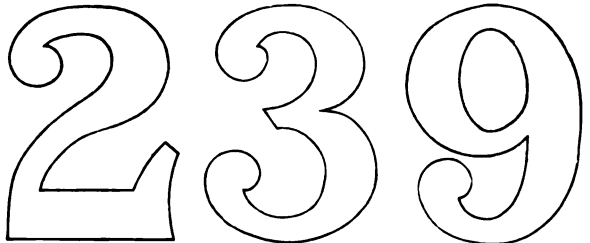

No. 4119C. 75 cts.



No. 12,178C. 50 cts.



No. 2425C. 40 cts.



No. 2466C. 50 cts.



No. 2681C. \$1.25



No. 170C. 40 cts.



No. 700E. 30 cts.



No. 868E. 35 cts.



No. 701E. 20c.



No. 865E. 30c.



No. 496E. 20c.



No. 2045E. 50c.



No. 3462C. \$1.00

No. 96R. 25 cts.



No. 527E. 25 cts.



No. 276B. 50 cts.



No. 455E. 20 cts.



No. 532E. 25 cts.



No. 4115F. 30 cts.



No. 2678C. 75 cts.

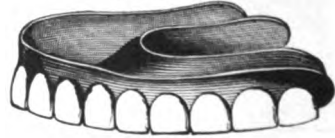

No. 3410C. \$1.00



No. 12,176C. 60 cts.

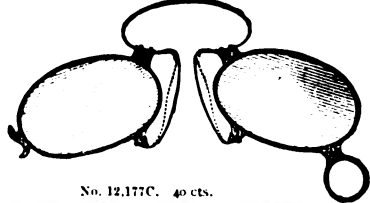

No. 12,177C. 40 cts.





No. 4186C. 75 cts.



No. 4020P. 20 cts.



No. 4188C. 75 cts.

No. 4123F. 35 cts.

No. 10,332D. 80 cts.



No. 468E. 20 cts.

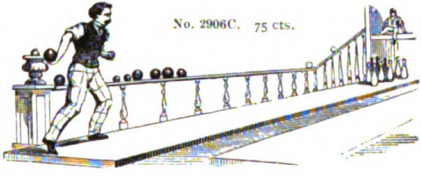
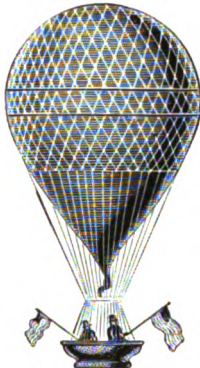

No. 2906C. 75 cts.



No. 743E. 25 cts.



No. 4126F. 30 cts.



No. 4124F. 30c.

No. 4125F. 30c.

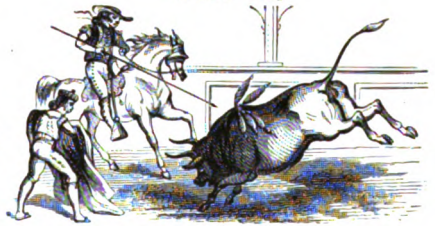

No. 3388C. \$1.25



No. 744E. 25 cts.



No. 3957C. 60 cts.

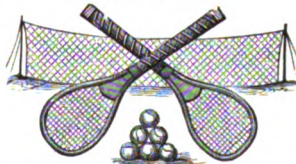

No. 3369C. \$1.25

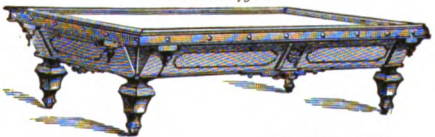

No. 3785C. 75 cts.



No. 4122F. 30c.



No. 3451C. 50 cts.

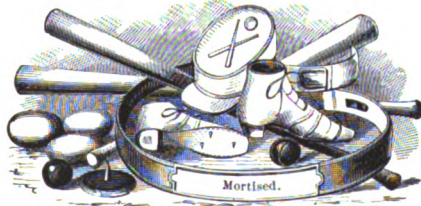

Mortised.



No. 12,173C. 40 cts.



No. 2687C. 25 cts.

No. 2092C. 50 cts.



No. 904E. 25 cts.



No. 3037C. 60 cts.



No. 3378C. 50 cts.



No. 3436C. 60 cts.



No. 2052E. \$1.00



No. 3204C. 60 cts.

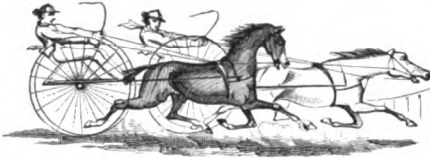

No. 2658F. 25c.



No. 3038C. 60 cts.



No. 3370C. 50 cts.



No. 2695C. 75 cts.



No. 3288C. 75 cts.



No. 2034E. \$1.00



No. 2055E. \$1.00



No. 2037E. \$1.00



No. 1629D. 75 cts.

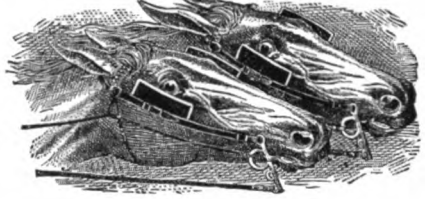

No. 732E. 25 cts.



No. 1856C. 50 cts.



No. 1796D. 35 cts.



No. 3434C. \$1.50

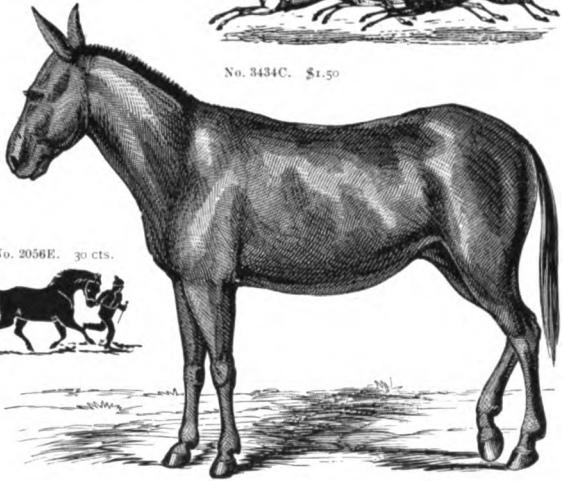

No. 2312½C. 38 cts.



No. 2056E. 30 cts.



No. 1733C. 50 cts.

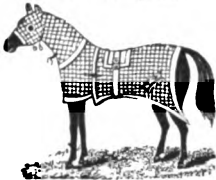

No. 3450C. \$2.00

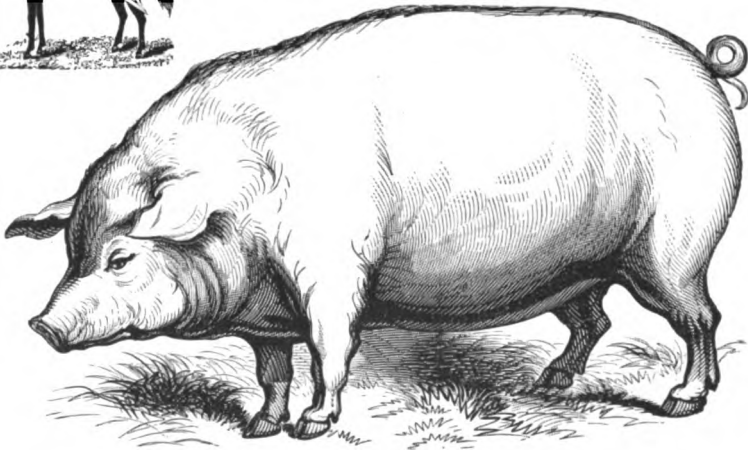

No. 2070C. \$2.00

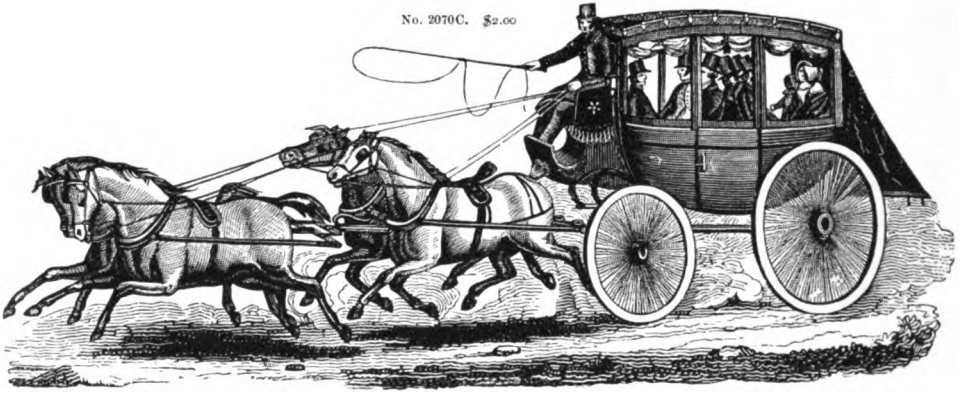

No. 1857C. 50 cts.



No. 2066E. \$1.00

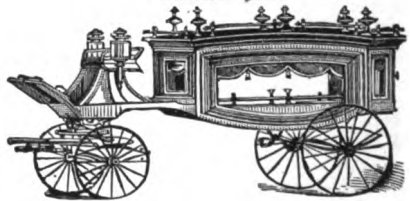

No. 3466C. \$1.00



No. 3380C. \$1.00



No. 2470C. 75 cts.



No. 2064E. \$1.00

No. 464E. 20 cts.



No. 2817C. 40 cts.



No. 465E. 15 cts.



No. 2063E. 50 cts.



No. 2854C. 50 cts.

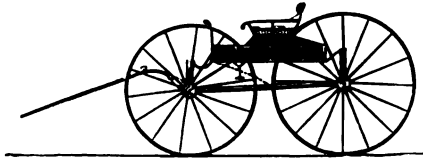

No. 2902C. 50 cts.



No. 2171C. 50 cts.

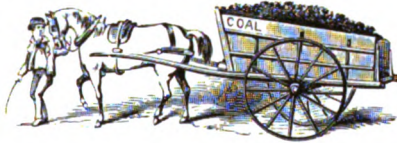

No. 4092C. 75 cts.



No. 322E. 15 cts.



No. 4093C. \$1.25

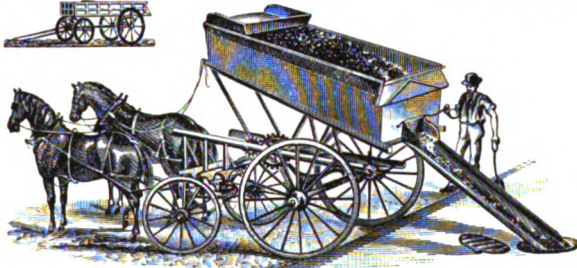

No. 4129F. 30 cts.



No. 466E. 15 cts.



No. 4168C. 60 cts.

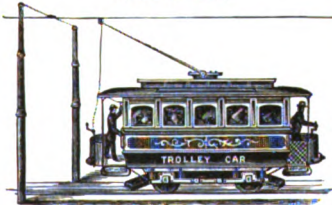

No. 2354C. 50 cts.



No. 4057F. 20 cts.



No. 717E. 25 cts.



No. 4167C. 40 cts.

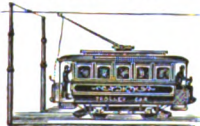

No. 2898C. Mortised. \$1.25

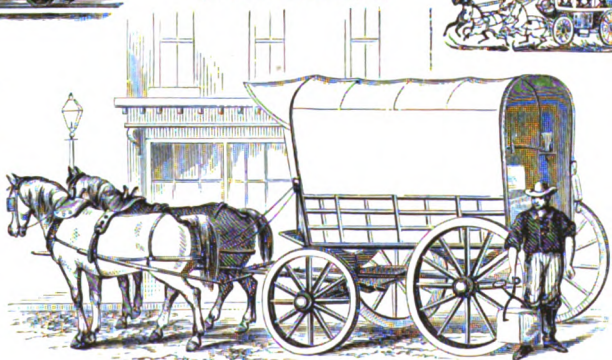

No. 2458C. 25 cts.





No. 265B. \$1.25



No. 4127C. 75 cts.



No. 3786C. 40 cts.



No. 3995C. 60 cts.



No. 2945C. 25 cts.



No. 850E. 30 cts.

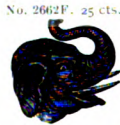

No. 2662F. 25 cts.



No. 672E. 25 cts.



No. 2090E. 40 cts.



No. 3677C. \$1.25



No. 2074E. 60 cts.



No. 1396D. 50 cts.

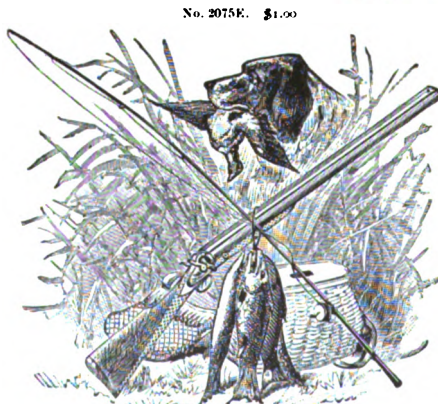

No. 2075E. \$1.00



No. 3674C. \$1.25

No. 5091C. \$1.00



No. 5100C. 50 cts.



No. 5164C. 75 cts.



No. 5160C. \$1.25



No. 5163C. \$1.00



No. 5099C. 75 cts.

No. 5098C. 50 cts.



No. 5097C. \$1.00



No. 5096C. 75 cts.

No. 2076E. 50 cts.



No. 5162C. \$1.25



No. 3787C. \$1.25



No. 2051E. 75 cts.



No. 2332C. \$1.00



No. 2463C. 50 cts.



No. 4065F. 20c.



No. 2050E. \$1.00

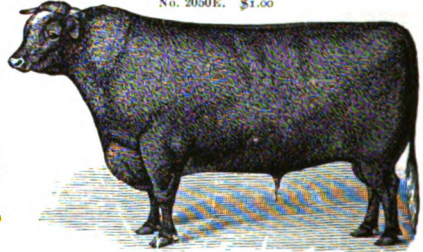

No. 616E. 15c.



No. 3756C. \$1.25



No. 3094C. 75 cts.



No. 2165C. \$1.50

No. 711E. 25c.



No. 709E. 25c.



No. 917E. 30c.



No. 2660F. 25c.



No. 731E. 25c.



No. 2657E. 20c.



No. 2033K. \$1.00

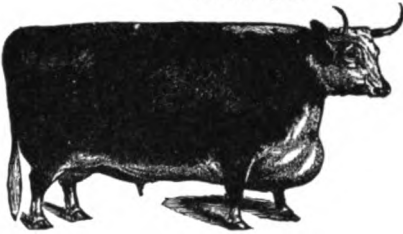

No. 2049K. \$1.00



No. 3396C. \$1.50

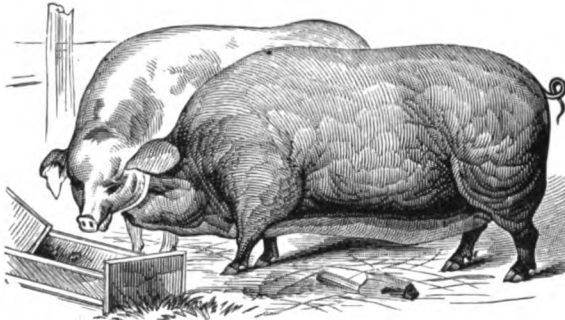

No. 3062C. 30 cts.



No. 3060C. 50 cts.



No. 1602D. 35 cts.



No. 1603D. 35 cts.



No. 1604D. 35 cts.



No. 1605D. 35 cts.



No. 1606D. 35 cts.



No. 1607D. 35 cts.



No. 1608D. 35 cts.



No. 1609D. 35 cts.



No. 1610D. 35 cts.



No. 1611D. 35 cts.



No. 1612D. 35 cts.



No. 1613D. 35 cts.



Cuts Nos. 1602D to 1613D, with Brands cut to order, 75 cents each.

No. 4099F. 30 cents each; \$2.50 per dozen.



No. 3054C. \$1.50



No. 1750A. 50 cts.



No. 3055C. 40 cts.



No. 2048E. \$2.00



No. 3800C. 30 cts.



No. 1752A. \$1.00



No. 4042F. 20 cents each; \$2.00 per dozen.



No. 4149F. 30 cents each; \$2.50 per dozen.

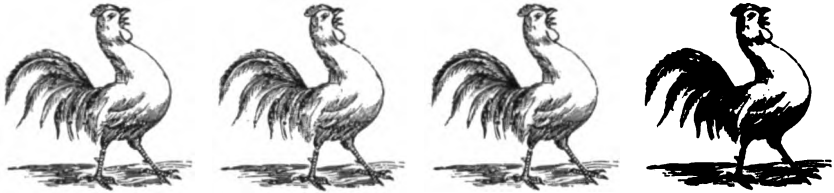

No. 2929C. \$1.00



No. 3559B. 50 cts.



No. 2047E. \$1.00

DEFEAT.



No. 859E. 30 cts.



No. 2046E. \$1.00

VICTORY.



No. 3816C. \$1.50

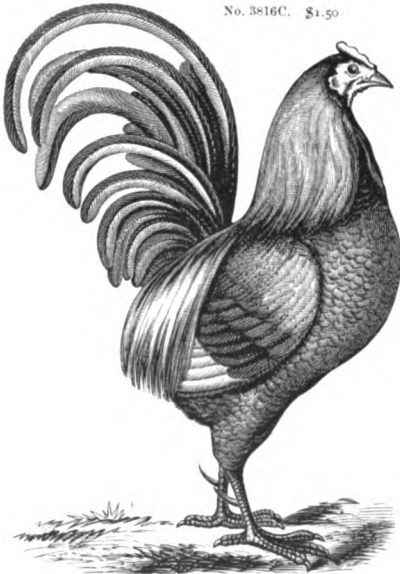

No. 4099C. \$1.00



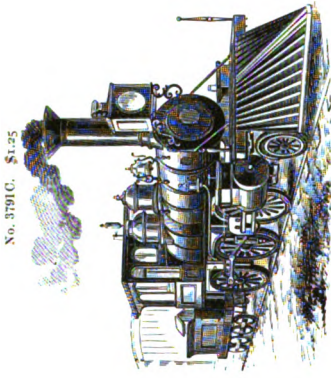

No. 3791C. \$1.25

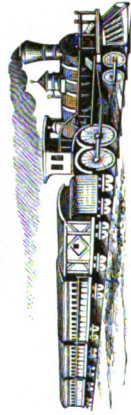

No. 3276C. 60 cts.

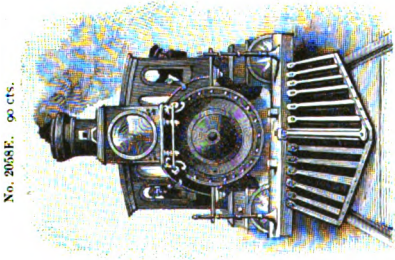

No. 2058E. 90 cts.

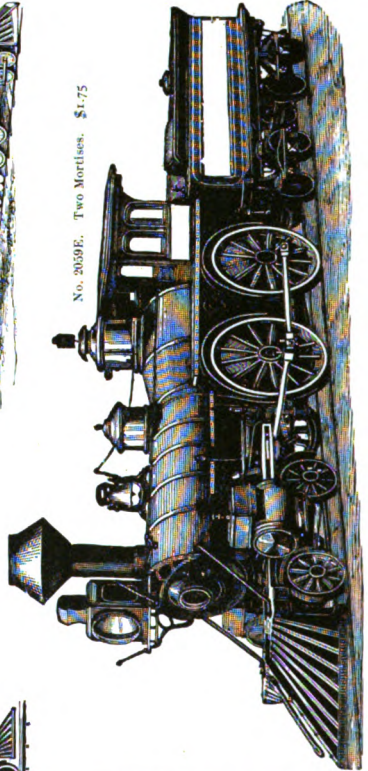

No. 2059E. Two Mortises. \$1.75



No. 2062E. \$1.00

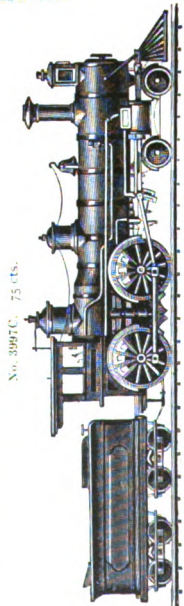

No. 3987C. 75 cts.

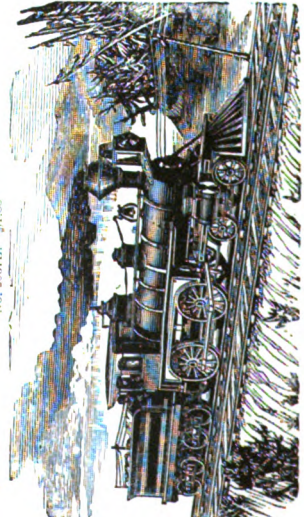

No. 2061E. \$1.00

No. 2072F, \$1.00

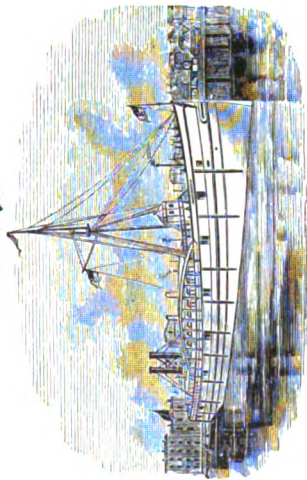

No. 2068F, \$1.00

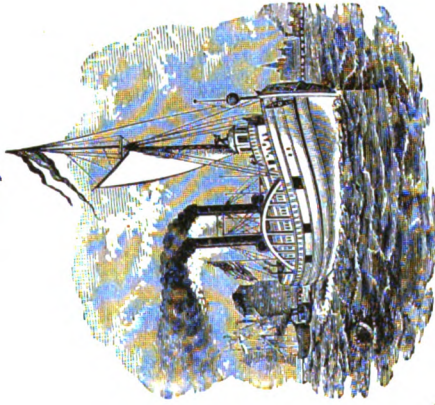

No. 2011F, \$1.00

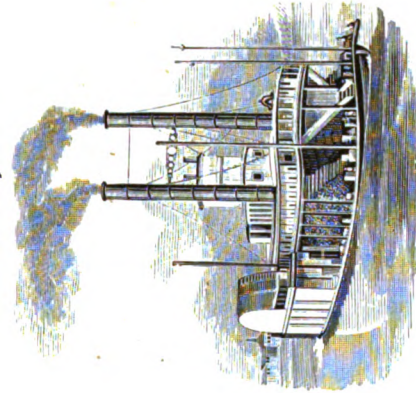

No. 2907C, \$1.00

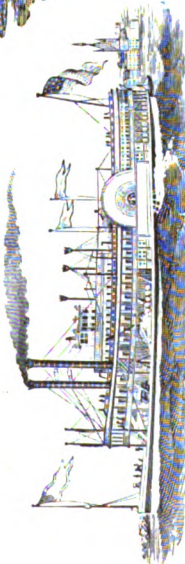

No. 2694D, 75 cts.

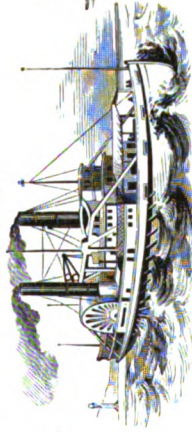

No. 2418C, 50 cts.



No. 3941C, \$1.00

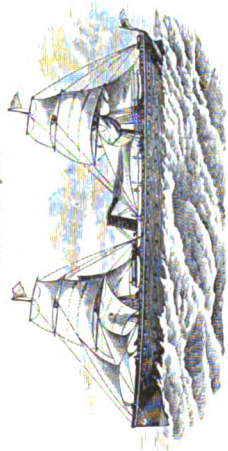

No. 3466C, 50 cts.

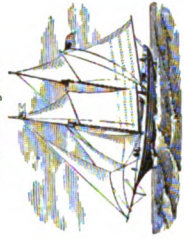

No. 2069E, 75 cts.



No. 4066C. 75 cts.

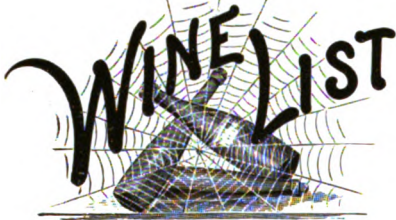

No. 4056. 75 cts.



No. 4065C. 75 cts.

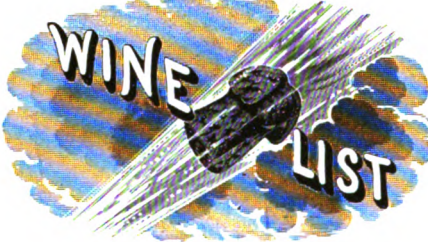

No. 4060C. 60 cts.

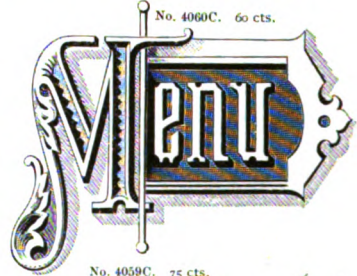

No. 4059C. 75 cts.



No. 4070C. 60 cts.

No. 4058C. 75 cts.



No. 4054C. 75 cts.



No. 4071C. 75 cts.



No. 4089C. 75 cts.



No. 4104C. 75 cts.



No. 4103C. 75 cts.



No. 3189C. 50 cts.



No. 2994C. 30 cts.



No. 2042C. 50 cts.

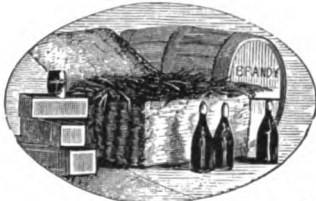

No. 2134C. 25 cts.



No. 3201C. \$1.25



No. 2285C. 37 cts.



No. 652E. 20 cts.



No. 3190C. 60 cts.

No. 3792C. \$1.25



No. 3712C. 40 cts.



No. 3024C. 75 cts.



No. 3298C. 50 cts.



No. 4105C. 75 cts.

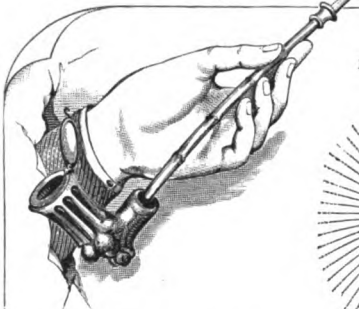

No. 4118C. 75 cts.



No. 275B. 50 cts.



No. 272B. 35 cts.



No. 4106C. 75 cts.



No. 271B. 50 cts.



No. 273B. 45 cts.



No. 269B. \$1.00



No. 270B. \$1.00



No. 2891C. 50 cts.



No. 2749C. 45 cts.



No. 3095C. 50 cts.

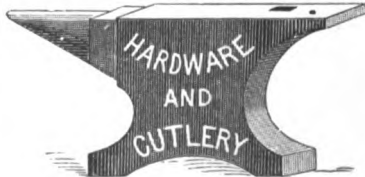

No. 4100C. 75 cts.



No. 4101C. 75 cts.

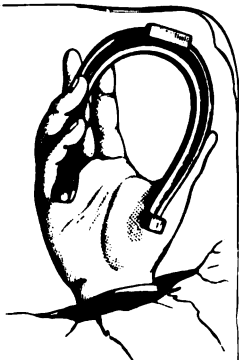

No. 3852D. 90 cts.

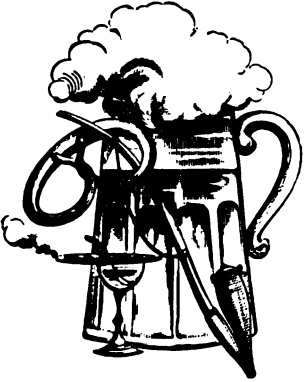

No. 2700C. Mortised. \$1.50



No. 5089C. 50 cts.



For four colors, \$2.00

No. 2255D. 80 cts.

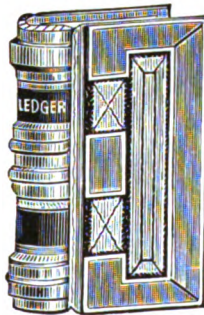

No. 1294D. 80 cts.

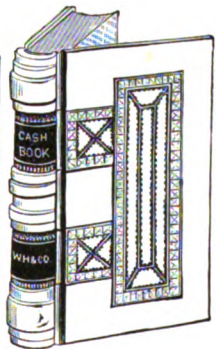

No. 3658C. Mortised. \$2.00

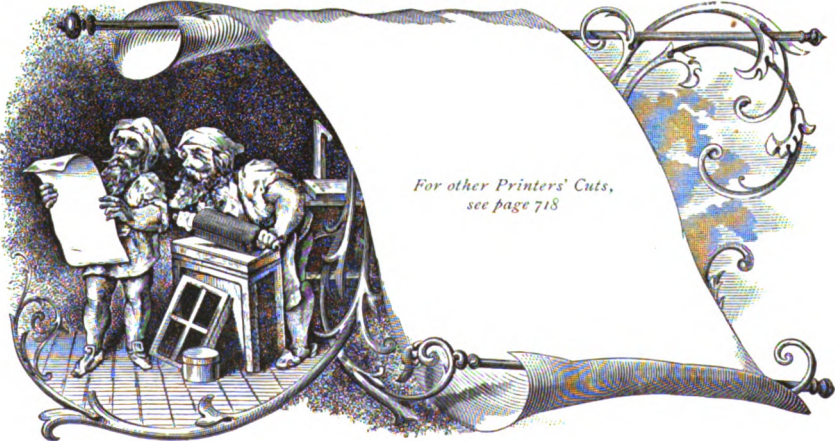

For other Printers' Cuts,
see page 718

No. 3484C. Mortised. \$1.00

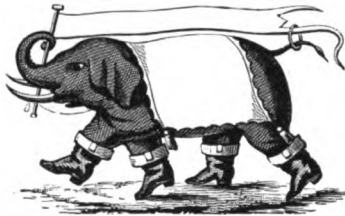

No. 4180C. 35 cts.



No. 4129C. 30 cts.



No. 2819C. Mortised. \$1.00

OTHER SIZE:

No. 2850C. 8 1/4 x 5 3/4 inches \$4.00

OTHER SIZES:

No. 2825C.	2 1/2 x 1 1/2 inches	\$.25
No. 2830C.	3 1/2 x 2 inches	1.50
No. 2835C.	8 1/2 x 5 1/2 inches	5.00
No. 2857C.	6 1/2 x 3 3/4 inches	3.00
No. 3207C.	11 1/2 x 8 inches	8.00

No. 2032E. 40 cts.



No. 3432C. 40 cts.



No. 3669C. 75 cts.



No. 3788C. \$1.00



No. 3440C. 75 cts. Mortised.

No. 4131C. 40 cts.



Mortised, extra, 30 cts.



No. 3679C. Mortised. \$1.50

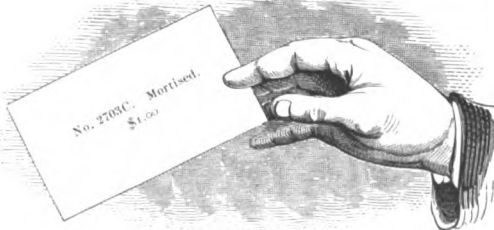

No. 2700C. Mortised. \$1.00



No. 2704C. Mortised. 75 cts.

OTHER SIZE:—No. 3160C. 5 1/2 x 3 3/4 inches \$2.75

ARMY AND NAVY No 1

12

PER FONT \$2 00



No. 2901C. \$1.00



ARMY AND NAVY No 2

12

PER FONT \$2 00



No. 4178C. Per Set, \$1.00



Not Mortised.



Army and Navy Cuts, Nos. 1 and 2, are Cast in Type Mould.

No. 4178C. Mortised for Name. Price per Set, \$2.00



No. 3359C. 50 cts.



No. 3353C. 50 cts.



No. 3867C. 60 cts.



No. 3852C. 60 cts.



No. 3878C. \$1.25



No. 3881C. \$1.25



No. 3902C. \$1.00



No. 3904C. \$1.00



No. 3501C. \$1.25

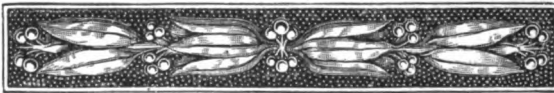

No. 3503C. \$1.25



No. 3872C. 75 cts.



No. 3466C. 60 cts.



No. 3885C. 50 cts.



No. 3711C. 35 cts. No. 3709C. 25 cts.



No. 3540C. 50 cts.



No. 3512C. 60 cts.



No. 3536C. 50 cts.



No. 3558C. 50 cts.



No. 3487C. 40 cts. No. 3486C. 40 cts.



WOOD TYPE.

The following series are selected from our Complete Specimen Book of Wood Type, which will be forwarded on application. It contains the most up-to-date, and also all the standard, styles of Wood Type, Borders and Ornaments.

Wood Type is priced by the letter, and sold in various sized fonts, as under. Orders for less than a font are strictly net; font orders are subject to discount. For schemes of fonts see our Specimen Book of Wood Type.

- 3A cap font contains 75 letters.
 - 4A cap font contains 106 letters.
 - 5A cap font contains 120 letters.
 - 3a lower-case font contains 65 letters.
 - 4a lower-case font contains 90 letters.
 - 5a lower-case font contains 104 letters.
- Figures are put up separately. Each font contains 26 characters, which include two \$ signs.

Customers should bear in mind that End-Wood Type can be made any size desired. A wood-type letter increases in width in exactly the same proportion as it does in length. For example: If a 12-line letter is 2 inches wide, the same letter in 15-line will be 2½ inches wide, the increase being one-quarter each way.

REVISED PRICE LIST PER LETTER.

This Price List of Wood Type Supersedes all Others Issued by Us.

The prices for all sizes of each style of type shown in this book can be found in this Revised Price List. The left-hand column gives the size of Type or lines Pica. The letters L, M, N, etc., at the top of table, give the class to which the letter belongs, and the figures in the different columns give the price per letter. The sizes of fonts are given above.

Always state whether CAPS alone are wanted, or CAPS and FIGURES, or CAPS, LOWER CASE and FIGURES, or CAPS and LOWER CASE, and how large a font or number of As.



Give full directions for shipping, unless it is desired to leave the matter to us, in which case we will ship the cheapest way, freight or express.

LINES PICA.	CLASSIFICATIONS.									
	L	M	N	O	P	Q	R	S	T	U
2-line	.06	.06	.06	.06	.06	.06	.08	.10	.13	.16
3-line	.06	.06	.06	.06	.06	.06	.08	.12	.15	.18
4-line	.06	.06	.06	.06	.06	.06	.08	.12	.15	.18
5-line	.06	.06	.06	.06	.07	.08	.09	.14	.17	.20
6-line	.06	.06	.06	.06	.08	.10	.11	.16	.19	.22
8-line	.08	.08	.08	.08	.10	.12	.13	.18	.22	.26
10-line	.09	.09	.10	.10	.12	.15	.16	.20	.25	.30
12-line	.10	.10	.12	.12	.14	.17	.18	.23	.28	.32
14-line	.11	.12	.13	.14	.16	.20	.22	.26	.30	.34
15-line	.12	.13	.14	.15	.18	.21	.24	.28	.32	.36
16-line	.12	.14	.15	.16	.19	.22	.25	.30	.34	.38
18-line	.13	.15	.17	.18	.21	.24	.28	.33	.37	.42
20-line	.14	.16	.18	.20	.24	.28	.32	.37	.40	.44
24-line	.17	.19	.22	.24	.28	.32	.36	.42	.45	.48
25-line	.18	.20	.23	.25	.30	.34	.38	.45	.48	.50
30-line	.21	.24	.27	.30	.35	.40	.44	.52	.55	.58
36-line	.28	.31	.34	.36	.41	.46	.50	.56	.59	.62
40-line	.33	.36	.38	.40	.45	.50	.56	.60	.63	.66
45-line	.36	.39	.42	.45	.50	.58	.63	.64	.67	.70
50-line	.45	.47	.48	.50	.56	.65	.70	.70	.72	.74
60-line	.50	.52	.56	.60	.6680	.83	.86
72-line	.60	.62	.64	.72	.7890	.95	1.00
80-line	.64	.66	.68	.80	.86	1.00	1.07	1.14
100-line	.75	.78	.80	1.00	1.06	1.15	1.25	1.35

All styles of Wood Type that are made can be furnished on receipt of sample at above prices, subject to liberal discount.





WOOD RULE.

12 cents per yard on side-wood ; 15 cents per foot on end-wood—in assorted lengths. End-wood Rule cannot be supplied in yard lengths. Solid corners to match all sizes, 25 cents per set of four. Wood Rule is sold at a lesser discount than Wood Type.

STYLE W	24 POINT
	
STYLE U	18 POINT
	
STYLE R	12 POINT
	
STYLE N	8 POINT
	
STYLE H	18 POINT
	
STYLE E	12 POINT
	



STAR RULE.

In fonts of 5 feet, with one set of Corners, \$1.90. Star Rule cannot be supplied in yard lengths.

No. 27	
No. 23	
No. 24	
No. 20	

WOOD POINTERS.

A set contains 25 pieces, matching those in our Metal Pointers.

		
2-line Pointers, per set, \$2.00	5-line Pointers, per set, \$3.50	
3 " " " " 2.50	6 " " " " 4.00	
4 " " " " 3.00	8 " " " " 5.00	

For other styles of Wood and Star Rules, see our Complete Specimen Book of Wood Type. Sent on application only.

END-WOOD BORDERS.

Kept in stock in 5-foot fonts, with one set of Corners. For a full sheet 10 feet of Border are required.

No. 244

5 FEET WITH CORNERS \$5 40



No. 333

5 FEET WITH CORNERS \$5 40

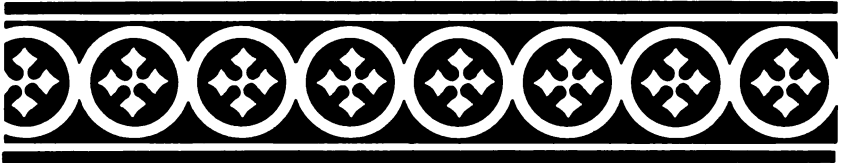

No. 131

5 FEET WITH CORNERS \$4 20



No. 295

5 FEET WITH CORNERS \$4 20



No. 110

5 FEET WITH CORNERS \$4 20



No. 254

5 FEET WITH CORNERS \$3 60



No. 259

5 FEET WITH CORNERS \$3 60



No. 250

5 FEET WITH CORNERS \$3 60



No. 40

5 FEET WITH CORNERS \$3 60



For a complete assortment of Wood Borders, see our Specimen Book of Wood Type. Sent on application only.

CLASS P

NO. 641. 10-LINE

12 CENTS PER LETTER

Bands

CLASS P

NO. 641. 8-LINE

10 CENTS PER LETTER

Bradley

CLASS P

NO. 641. 6-LINE

8 CENTS PER LETTER

Founders 5

CLASS P

NO. 641. 5-LINE

7 CENTS PER LETTER

Predominate

For sizes of fonts and prices of other sizes of this series see page 793. For specimens of other sizes see our Specimen Book of Wood Type, which is sent only upon application. Lower case and figures made for all sizes.

CLASS P

No. 650, 10-LINE

12 CENTS PER LETTER

Ran

CLASS P

No. 650, 8-LINE

10 CENTS PER LETTER

Coast

CLASS P

No. 650, 6-LINE

8 CENTS PER LETTER

Disturb

CLASS P

No. 650, 5-LINE

7 CENTS PER LETTER

Sampson

For sizes of fonts and prices of other sizes of this series see page 793. For specimens of other sizes see our Specimen Book of Wood Type, which is sent only upon application. Lower case and figures made for all sizes.

CLASS O

NO. 642, 10-LINE

10 CENTS PER LETTER

Great

CLASS O

NO. 642, 8-LINE

8 CENTS PER LETTER

Stands

CLASS O

NO. 642, 6-LINE

6 CENTS PER LETTER

Decorate

CLASS O

NO. 642, 5-LINE

6 CENTS PER LETTER

Establish 5

For sizes of fonts and prices of other sizes of this series see page 793.
For specimens of other sizes see our Specimen Book of Wood Type, which is
sent only upon application. Lower case and figures made for all sizes.

CLASS O

NO. 644. 10-LINE

10 CENTS PER LETTER

Coat

CLASS O

NO. 644. 8-LINE

8 CENTS PER LETTER

Broth

CLASS O

NO. 644. 6-LINE

6 CENTS PER LETTER

Opera 4

CLASS O

NO. 644. 5-LINE

6 CENTS PER LETTER

Mountain

For sizes of fonts and prices of other sizes of this series see page 793. For specimens of other sizes see our Specimen Book of Wood Type, which is sent only upon application. Lower case and figures made for all sizes.

CLASS O

No. 627, 10-LINE

10 CENTS PER LETTER

Mad

CLASS O

No. 627, 8-LINE

8 CENTS PER LETTER

Colts

CLASS O

No. 627, 7-LINE

8 CENTS PER LETTER

Break

CLASS O

No. 627, 6-LINE

6 CENTS PER LETTER

Grants

For sizes of fonts and prices of other sizes of this series see page 793.
For specimens of other sizes see our Specimen Book of Wood Type, which is
sent only upon application. Lower case and figures made for all sizes.

CLASS O

NO. 629, 10-LINE

10 CENTS PER LETTER

Backs

CLASS O

NO. 629, 8-LINE

8 CENTS PER LETTER

Hunter

CLASS O

NO. 629, 6-LINE

6 CENTS PER LETTER

Exhibited

CLASS O

NO. 629, 5-LINE

6 CENTS PER LETTER

Celebration

For sizes of fonts and prices of other sizes of this series see page 793. For specimens of other sizes see our Specimen Book of Wood Type, which is sent only upon application. Lower case and figures made for all sizes.

CLASS N

No. 646, 10-LINE

10 CENTS PER LETTER

DONE

CLASS N

No. 646, 8-LINE

8 CENTS PER LETTER

MISER

CLASS N

No. 646, 6-LINE

6 CENTS PER LETTER

MOUNDS

CLASS N

No. 646, 5-LINE

6 CENTS PER LETTER

PINE CONE

For sizes of fonts and prices of other sizes of this series see page 798.
For specimens of other sizes see our Specimen Book of Wood Type, which is sent only upon application. Lower case and figures made for all sizes.

CLASS N

No. 231. 10-LINE

10 CENTS PER LETTER

BISON

CLASS N

No. 231. 8-LINE

8 CENTS PER LETTER

NORMS

CLASS N

No. 231. 6 LINE

6 CENTS PER LETTER

Rancher 3

CLASS N

No. 231. 5 LINE

6 CENTS PER LETTER

Old Banker 5

For sizes of fonts and prices of other sizes of this series see page 793. For specimens of other sizes see our Specimen Book of Wood Type, which is sent only upon application. Lower case and figures made for all sizes.

CLASS R

NO. 649, 9-LINE

16 CENTS PER LETTER



Cuba

CLASS R

NO. 649, 8-LINE

13 CENTS PER LETTER



Grain

CLASS R

NO. 649, 6-LINE

11 CENTS PER LETTER



Blanks

CLASS R

NO. 649, 5-LINE

9 CENTS PER LETTER



Captured

For sizes of fonts and prices of other sizes of this series see page 793. For specimens of other sizes see our Specimen Book of Wood Type, which is sent only upon application. Lower case and figures made for all sizes.

*ILLUSTRATED Catalogue
and Price List of Printing
Machinery and Supplies, Wood
Goods, and Fine Printing Inks*



...American...
Type Founders Company
Everything for the Printer
1898



NOTICE TO BUYERS

The American Type Founders' Company offers only the best lines of Printing Material and Machinery, covering all the requirements of the printing office.

As the largest buyer in the world of this class of goods, it commands the best in the market at the lowest prices, and is in the best possible position to satisfy its customers.

Buyers of large or small outfits will always receive the best money's worth. Detailed estimates will be furnished, on application to the nearest Branch, upon receipt of information concerning the amount to be invested, terms required, and work to be done with such outfits.



FOR THE COMPOSING ROOM.

BODKINS.



No. 1, wood handle, needle steel,
each \$0 10



No. 2, wood handle, needle steel,
each \$0 10

TWEEZERS.



This is good and cheap; polished steel; Nonpareil points.

No. 11, nickel-plated, each \$0 25



This is the best Tweezer procurable at the price; file point, steel, 4 inches long.

No. 5, nickel-plated, each \$0 50



These are the best made; tempered steel, nickel-plated, file-cut points and backs. No. 7 is 4 inches long; No. 8, 4 3/4 inches long.

No. 7, nickel-plated, 4 inches long, each \$0 75
No. 8, nickel-plated, 4 3/4 inches long, each 0 85



The only Tweezer that can be carried in the pocket with comfort and safety. It locks and unlocks automatically. Hold it points down and press between fingers gently, and it unlocks; hold it points up and bring points together, and it locks securely.

No. 9. Self-locking, nickel-plated, each \$0 90



When Tweezer is in use the Bodkin folds into it. When Bodkin is required, pressure on the file-cut arc shown in cut brings it out easily, and when extended it locks securely, and is as firm as an ordinary Bodkin. This is the latest and most satisfactory combination. Patent applied for.

No. 3. Combination Tweezer and Bodkin, nickel-plated, each \$1 00

PAGE CORD.



The real thing. 8-ply Charter Oak Cotton.
8 ounce balls, each \$0 25

PRINTERS' EYE SHADE.

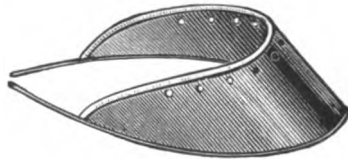

Per dozen \$1 50
Each 0 15

COMPOSING STICKS.

THE BUCKEYE.

Quick and easy to set; will not slip; lies flat; as secure as the Common Screw Stick, and easier to set than the Yankee Job Stick.



6 ins. × 2, 2¼ or 2½ ins. deep	..	\$0 90
8 ins. × 2, 2¼ or 2½ ins. deep	..	1 00
10 ins. × 2, 2¼ or 2½ ins. deep	..	1 20
12 ins. × 2, 2¼ or 2½ ins. deep	..	1 40
14 ins. × 2, 2¼ or 2½ ins. deep	..	1 60
16 ins. × 2, 2¼ or 2½ ins. deep	..	1 80
20 ins. × 2, 2¼ or 2½ ins. deep	..	2 20
24 ins. × 2, 2¼ or 2½ ins. deep	..	2 60

YANKEE JOB.

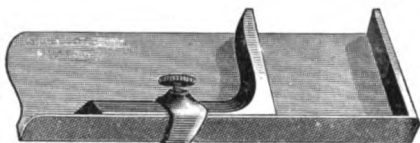

6 ins. × 2, 2¼ or 2½ ins. deep	..	\$0 75
8 ins. × 2, 2¼ or 2½ ins. deep	..	0 80
10 ins. × 2, 2¼ or 2½ ins. deep	..	1 00
12 ins. × 2, 2¼ or 2½ ins. deep	..	1 15
14 ins. × 2, 2¼ or 2½ ins. deep	..	1 30
16 ins. × 2, 2¼ or 2½ ins. deep	..	1 45
18 ins. × 2, 2¼ or 2½ ins. deep	..	1 60
20 ins. × 2, 2¼ or 2½ ins. deep	..	1 75

COMMON SCREW.

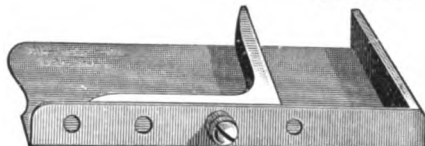

6 ins. × 2, 2¼ or 2½ ins. deep	..	\$0 75
8 ins. × 2, 2¼ or 2½ ins. deep	..	0 80
10 ins. × 2, 2¼ or 2½ ins. deep	..	1 00

Other sizes to order at same prices as Yankee Job Sticks.

THE GROVER.

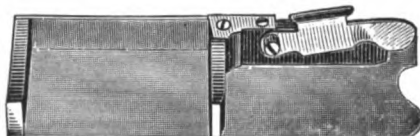

6 × 2¼ inches	..	\$0 90
8 × 2¼ inches	..	1 00
10 × 2¼ inches	..	1 20
10½ × 2½ inches (billhead)	..	1 60
12 × 2¼ inches	..	1 40
16 × 2¼ inches	..	1 80

Extra Clasps, 10 cents; extra Knees, 40 cents each.

• "C" SLOT STICK.

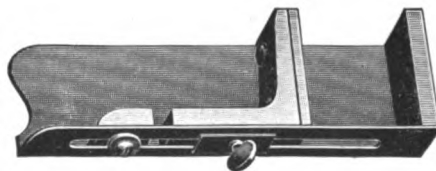

Has two entirely novel features: (1) The inside of face of the knee is adjustable, so that it can be squared up in case the knee wears; (2) The knee is in two sections, so that the Stick can be set to shorter measure without changing the full measure adjustment. See cut, which shows part of the knee at the left set for full measure, while the main part is set to a lesser measure.

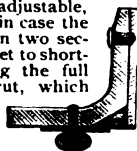

6 ins. × 2¼ ins. deep	..	\$1 15	10 ins. × 2¼ ins. deep	..	\$1 45
8 ins. × 2¼ ins. deep	..	1 25	12 ins. × 2¼ ins. deep	..	1 65

STANDARD JOB COMPOSING STICK.



Sets instantly to Nonpareils or Picas, of the point system only, without the use of leads or quads, and once set cannot possibly slip.

	2 ins.	2¼ ins.	2½ ins.
6 inches	.. \$1 75	\$1 85	\$1 95
8 inches	.. 2 00	2 10	2 20
10 inches	.. 2 25	2 35	2 45
12 inches	.. 2 50	2 60	2 70

PERFECT NEWS STICKS.

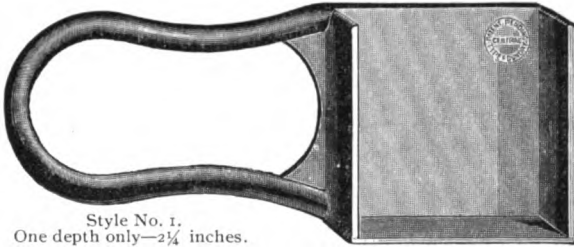

Style No. 1.
One depth only—2¼ inches.

These Sticks are made for setting one measure only, either 13 or 13½ ems Pica, and prevent all the annoyances due to variations in Sticks set inaccurately by careless compositors. It is undoubtedly the best Stick made for news measures.

Style No. 1 is made of best malleable iron; the handle and under side are japanned, so that the Stick cannot rust; the pan itself is milled out,

the sides being absolutely square and rigid, and altogether the Stick is as perfect as could be desired. Made one depth—2¼ inches—only, and for 13 or 13½ ems Pica measure.

Style No. 2 is made of the best of steel, and the set bar or knee is riveted firmly to bottom and back of Stick. It is accurate in every respect.

These Sticks are made for 13 or 13½ ems Pica measure, and are 2¼ inches deep.

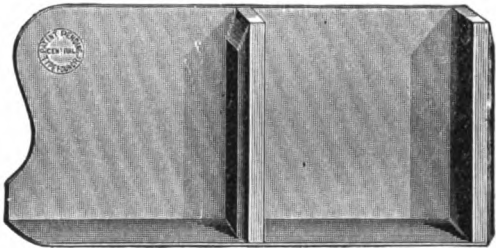

Style No. 2.

- No. 1. Malleable Iron, milled, for 13 or 13½ ems Pica measure \$0 75
 No. 2. Steel-riveted, for 13 or 13½ ems Pica measure 0 80

WOODEN POSTER STICK.



With brass-lined ends, iron knee and screw clamp.

- 16 inches \$1 00
 20 inches 1 10
 24 inches 1 20
 30 inches 1 35
 36 inches 1 50
 42 inches 1 80

COMPOSING AND MAKE-UP RULES.

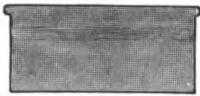

Steel Composing Rules, 15 ems and under, each \$0 25

Add 5 cents to above from 15 to 20 ems, and 10 cents extra from 20 to 25 ems.

Nickel plating, 15 cents extra.

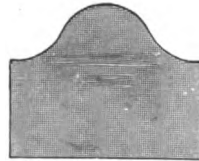

Steel Make-up Rules, 15 ems and under, each \$0 30



Set of 12 Steel Composing Rules, in leather case \$1 50

COMPOSING STICK RACK.

This Rack holds twelve Sticks, and can be attached to the wall or any other convenient place. The Sticks are held securely, and are preserved from the damage liable to them when "kicking about."

Each \$1 50

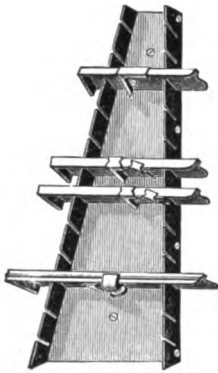

KELSEY COPY HOLDER.

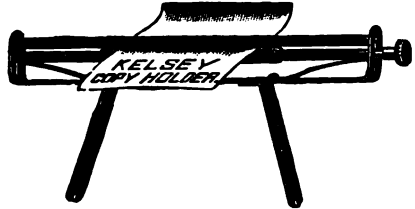

Price, each \$0 75

BRASS LABEL HOLDER.



The utility of these Label Holders is apparent at a glance, especially when extra men are put on, as it enables them to locate the type quickly.

Size, 1 x 5 1/2 inches, per hundred, with cards and tacks complete \$2 75
 Size, 1 x 5 1/2 inches, per dozen (least quantity sold), complete 0 50

Other sizes furnished to order.

TYPE MEASURES.

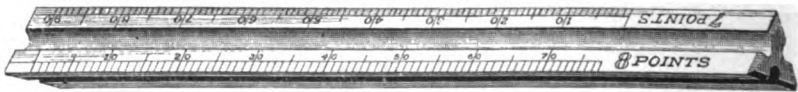

Boxwood Triangular Type Measure.

Boxwood, triangular shape, the best, 9 inches \$1 50
 Boxwood, triangular shape, the best, 18 inches 3 00

This Type Measure is superior to any, and is guaranteed to be accurate. The sides of the triangle are grooved, so that it is easily handled. It will measure any size from 5 1/2 Point to 18 Point, and all multiples of 6 Point.

Square Brass-Edged Wooden Type Scale, No. 120 \$0 30

Measures 5 1/2, 6, 7, 8, 9, 10, 11 and 12 Points, and has 12-inch scale.

Patent 12-inch Cardboard Type Scale \$0 25

Measures 4 1/2, 5, 5 1/2, 6, 7, 8, 9, 10, 11, and 12 Points, and has 12-inch scale.

Lincoln Type Measure, steel tape, 24 inches long, in German silver case, each \$2 00

Measures 376 lines of Agate (14 lines to the inch); 288 of 6 Point; 246 of 7 Point; 216 of 8 Point; 192 of 9 Point; 172 of 10 Point; 157 of 11 Point; 144 of 12 Point, and has a 24-inch scale, all plainly marked.

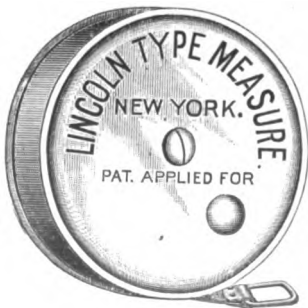

Exact size.

WOODEN MALLETS.

Made of thoroughly seasoned and selected stock; handles screwed in; finished in oil; attractive shape. The Lignumvitæ Mallets can be specially recommended. They are heavier than Hickory Mallets, and wear like iron.

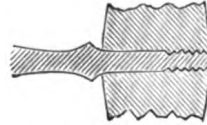

Shows Handle screwed in.

Hickory, small, 2½ × 4½	\$0 25	Lignumvitæ, 2½ × 3½	\$0 50
Hickory, medium, 3 × 5	0 30	Lignumvitæ, 3 × 5	0 60
Hickory, large, 3½ × 6	0 40	Lignumvitæ, 3½ × 5½	0 75
IRON BOUND WOODEN Mallet			1 00

PATENT RAWHIDE MALLETS.

This mallet is made entirely of rolled rawhide, except handle, which is of wood.

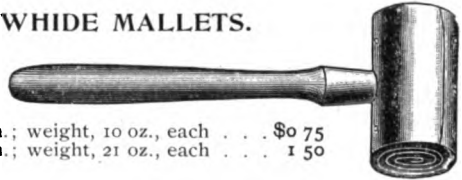

No. 4. Diameter, 2 in.; length, 3¼ in.; weight, 10 oz., each	\$0 75
No. 5. Diameter, 2½ in.; length, 4¼ in.; weight, 21 oz., each	1 50

RAWHIDE-RUBBER Mallet.

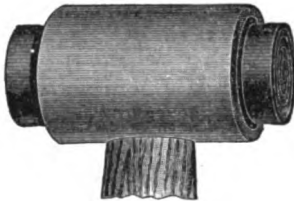

The striking parts of mallet are of rawhide, held by an iron body piece. The iron piece is covered with rubber as a protection to the type in case the mallet falls on, or is laid on, the form. When the rawhide striking parts (or faces) wear out, new faces can be inserted in the iron body piece.

No. 2. Diameter of face, 1½ in., each	\$1 25
Extra Rawhide Faces, per pair	0 40

PLANERS.

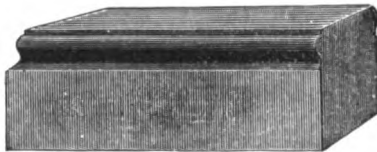

Maple, small, 3 × 6	\$0 25
Maple, large, 3½ × 8	0 30
Maple, leather top, 3½ × 8	0 40

PROOF PLANERS.

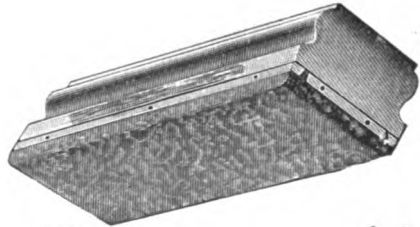

3½ × 8	\$0 60
------------------	--------

LINOTYPE PLANER.

The Linotype Planer has a corrugated rubber face and is used for removing the burr from linotype slugs.

Price, each	\$0 50
-----------------------	--------

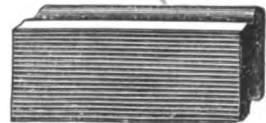

MITER BOXES.

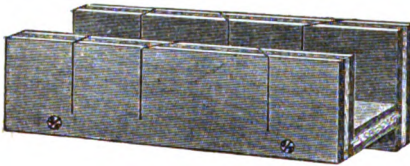

Our Improved Wood Miter Boxes are made of 3-ply glued stock, and will outlast the usual kind three to one. Will not break if thrown on the floor, and will resist all sorts of careless usage.

- Wood, 1 3/4 ems wide, each \$0 50
- Wood, 3 inches wide, each 0 60
- IRON, each 2 50

BELLOWS.

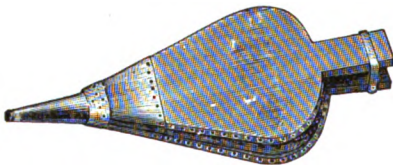

These Bellows are correct in shape, and strongly made of the best materials.

- Small size \$1 00
- Large size 1 25

SAW.



- Back Saw, for cutting wood or soft metal \$1 25

PRINTER'S DIVIDERS.



Always useful in laying out margins and distances, imposing plate forms, etc. A great time saver.

- Price, each \$0 85

LEADER BOXES.

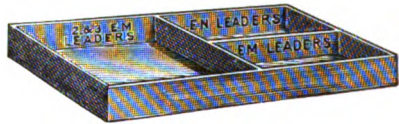

Just "the thing" for holding leaders. The size is 5x8x1 1/4 inches.

- Price, per dozen \$2 50
- Each 0 25

KEYSTONE HACK SAWS.

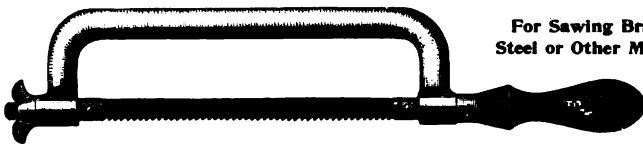

For Sawing Brass, Steel or Other Metals.

The saw blade is secured to the iron frame by two pins, and may be detached easily. When worn it is cheaper to put in a new blade than to refit. One dozen extra blades are furnished with each frame. This is a useful tool in any printing office for cutting thick brass rules, iron side sticks, etc.

- Eight-inch Keystone Hack Saw, polished frame, with one dozen saw blades . . . \$1 50
- Extra blades, eight-inch, per dozen 1 00

SHOOTING STICKS.



- No. 3, wrought steel, nickel-plated, large, each \$0 75
- No. 2, wrought steel, nickel-plated, small, each 0 60



- Malleable iron, jappanned, each 0 30



- Hickory Shooting Stick, per dozen, 85 cents . . each, 0 08

LEAD AND RULE CUTTERS.

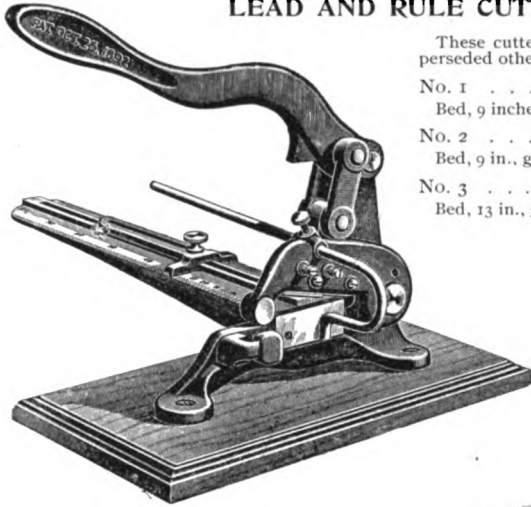

These cutters are the best made, and have superseded other styles all over the world.

No. 1 \$8 00
Bed, 9 inches; gauges 12 inches.

No. 2 \$9 00
Bed, 9 in., graduated to Picas; gauges 12 in.

No. 3 \$12 00
Bed, 13 in., graduated to Picas; gauges 18 in.

No. 12 \$10 00
Gauges 12½ in. at back and 11½ in. at front, graduated to Picas.

No. 18 \$14 00
Gauges 18½ in. at back and 14 in. at front, graduated to Picas.

CHANDLER & PRICE LEAD AND RULE CUTTER.

The bed is nearly vertical, and the lead or rule drops against the gauge edge by gravity, assuring a square cut. The bed and gauge are graduated to Picas.

Gauges 14 inches \$8 00

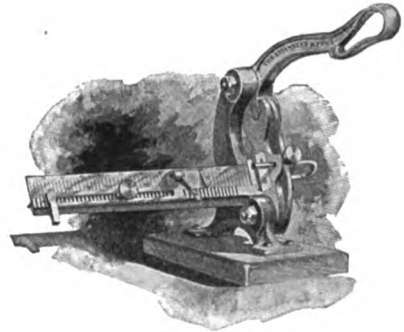

HANDY LEAD CUTTER.

Will cut leads and slugs six points thick, and, although not recommended as a rule cutter, will cut two-point brass rule. Has back and front gauges.

Leads can be cut very rapidly and easily on this cutter by holding the lever and the handhold on frame in right hand, as in using hand shears. To get the best results this cutter should be screwed to bench or table.

Price \$4 00

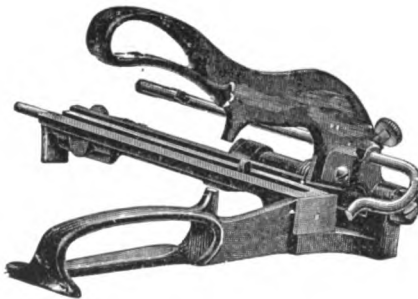

UTILITY LEAD CUTTER.

The strongest cheap Lead Cutter made. A reliable, cheap tool.

Price \$2 00

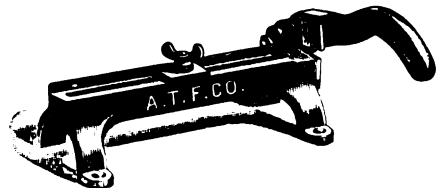

PATENT UPRIGHT MITER MACHINE.

A strong, well-built, accurate machine. The cutting or shaving head has a positive up and down motion, and must cut as much at the bottom as at the top, as it cannot slip. The knife is regulated by set-screw. The sliding gauge is the best of its kind, enabling the operator to feed the rule up to the knife, but affords a positive check at the point where the desired length is reached. The bed is graduated, and is made movable, so that the whole cutting-edge of knife can be used. This machine is mounted in a strong, shallow, wooden box, which catches the shavings, and has at the front end an emery board on which the burr of the rules may be rubbed off.

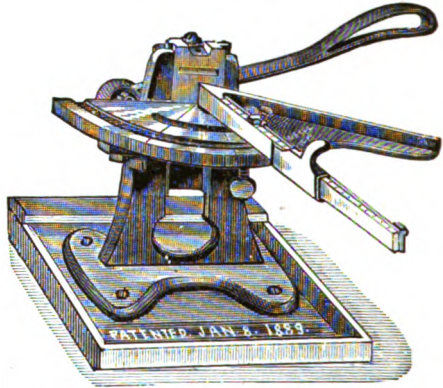

With Sliding Gauge \$13 00
With Micrometer Point-System
Gauge 20 00

GOLDING UPRIGHT MITERER.

This machine differs in principle from the Patent Miterer (described on this page) in this: the rule is held stationary, and the knife is fed up to it, while in the Patent Miterer the knife is stationary and the rule is fed to it. The knife of the Golding Miterer is movable, but it is pivoted in such a way as to enable it to make a positive downward cut the same at the bottom as at the top. The knife adjustment is specially good. The bed is graduated and is made movable, so that the whole cutting-edge of the knife may be used.



Price, boxed \$14 00

**CHANDLER & PRICE
ROTARY MITERING MACHINE.**

The knife is made of the best steel, and is easily removed and sharpened. By adjusting the screw at the end of the hub, the cutting wheel receives sufficient movement on the stud to readily admit of cutting rule to exact lengths.

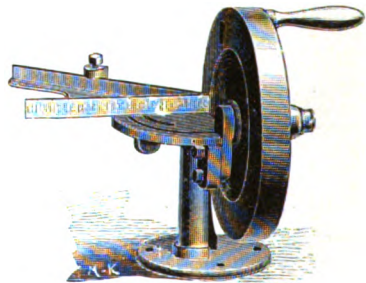

Price, \$15 00

ELITE RULE BENDER.



The blade is tool steel and the cylinders of brass. Bends rule from one to six points in thickness. The end of the rule is firmly held in the grooves in cylinder, and can be twisted into any shape.

Price, with instructions for rule bending \$2 00

GOLDING RULE-CURVING MACHINE.

This machine curves brass rule from one-quarter inch to eight inches in diameter by pressure exerted by the screw on curved brass plates, between which the rule is put at the proper place to get the required curve, as indicated by a scale engraved on the bed. Smaller curves can be made on this machine than on any other. An attachment is supplied for forming square corners as a substitute for mitered corners. Brass rule for curving or bending should be annealed. All brass rule made by us can be annealed to order at a slight extra charge.

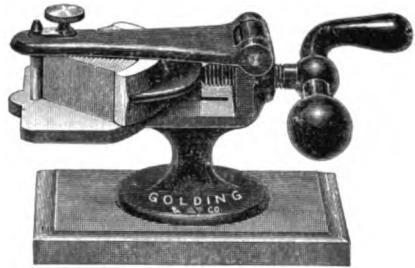

No. 1, curves one-quarter to four inches diameter	\$12 00
No. 2, curves three-eighths to eight inches diameter	18 00
Dies for forming square corners, per set	1 50

PRINTERS' CURVING MACHINE.

On this machine the curves are made by pressure between three iron rollers (two below and one on top), and the pressure is regulated by the screw at left hand side, which acts on a lever that raises or depresses the lower iron rollers. The action is very rapid, and, in the hands of an expert, accurate.

Price \$15 00

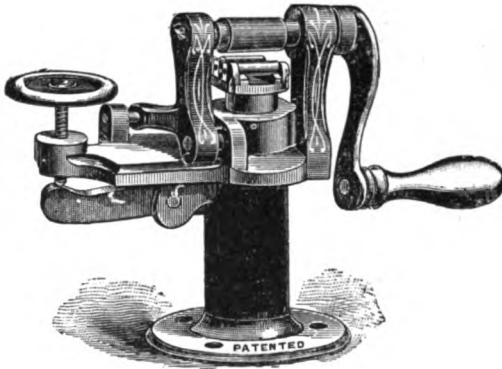

LITTLE GIANT RULE SHAPER.

The rule is held flat on the bed by the clamp (2). The gauge (5) is graduated to Picas by notches, and is regulated by the pointer (4), which engages in the notches. Five steel cutting tools of different angles are furnished with each machine. The cutting tool is held in the head (1). By turning the wheel the cutter is moved back and forth over the rule, sinking deeper at each cut, and when it completes the cut it is lifted automatically, ready for the next cut. If the rule is thinner than 12 Points, the head (1) may be brought down to the rule by moving the lever (3). Any thickness of rule up to 12 Point may be mitered. At each cut both sides of the miter are made, and join without further trimming. This machine is not designed for trimming the ends of leads and rules, and therefore does not supersede the upright miterer; but in offices where much mitering is done it will prove a time and rule saver, as it mitters very rapidly.

Send for illustrated circular.

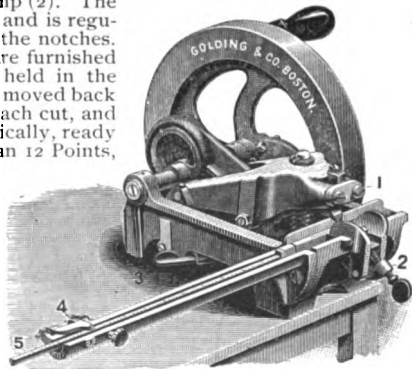

Price	\$35 00
Patent graduated gauge, extra	4 00

SMOOTH-LINED BRASS GALLEYS.

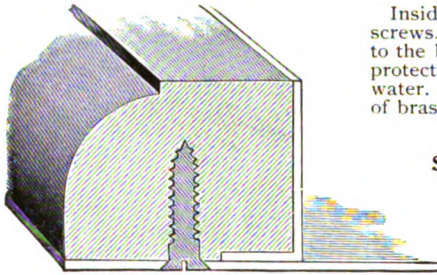

Sectional end view, showing how the brass lining protects the wood rim from action of lye and water.

Inside they are perfectly smooth and free from screws. The lining is angle brass, and is soldered to the bottom plate, strengthening the sides, and protecting the wood rim from the action of lye and water. The head is supported by a strong strip of brass.

SMOOTH-LINED JOB GALLEYS.

6 × 10 inches inside	\$2 00
8½ × 13 inches inside	2 50
10 × 16 inches inside	3 00
12 × 18 inches inside	3 50
14 × 20 inches inside	4 00
15 × 22 inches inside	5 00
18 × 25 inches inside	5 75

SMOOTH-LINED COLUMN GALLEYS.

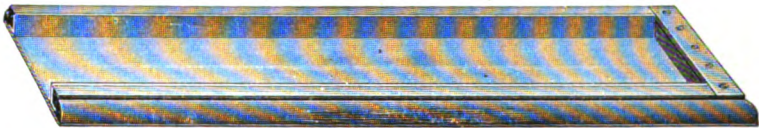

Smooth-lined Column Galley, showing Brass Plate at Head.

Single Column, brass-lined, 3½ × 23¼ inches inside	\$2 00
Single Column, brass-lined, 3½ × 11¾ inches inside	1 50
Medium width, brass-lined, 4¾ × 23¼ inches inside	2 25
Double Column, brass-lined, 6¼ × 23¼ inches inside	2 50
Triple Column, brass-lined, 8½ × 23¼ inches inside	3 00
Single Column, half-lined, 3½ × 23¼ inches inside	1 75
Double Column, half-lined, 6¼ × 23¼ inches inside	2 25

PATENT-LINED GALLEYS.



Fig. 1.

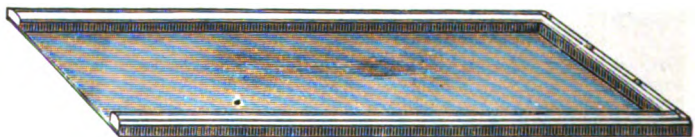

Fig. 2.

The wood rim has a brass lining driven into it, as illustrated in Fig. 1, thus avoiding the use of screws. The wood rims are secured to the bottom by screws.

PATENT-LINED COLUMN GALLEYS.

	Size inside.	Full-lined.	Half-lined.
Single Column	3½ × 23¼	\$2 00	\$1 75
Medium Column	5 × 23¼	2 25	2 00
Double Column	6¼ × 23¼	2 50	2 25

PATENT-LINED JOB GALLEYS.

6 × 10 inches inside	\$1 50	12 × 18 inches inside	\$3 75
8½ × 13 inches inside	2 00	14 × 21 inches inside	4 50
9 × 14 inches inside	2 50	15 × 22 inches inside	5 00
10 × 16 inches inside	3 00	18 × 25 inches inside	6 00

SUCCESS RIVETED ALL-BRASS GALLEYS.

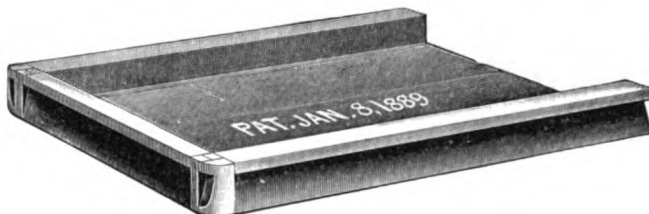

Made of heavy brass, the sides *riveted* strongly to the bottoms, and the corners locked together by a patented hold, which effectually resists all the strain of locking-up. These galleys will be found to be a great improvement over those galleys with bottoms screwed to the sides. The list prices remain the same as charged for



Shows method of securing sides to bottom by rivets.



Shows patent corner hold.

galleys with bottom secured by screws. These galleys have been the standard for quality and construction for several years, and are still unexcelled.

ALL-BRASS COLUMN GALLEYS.

Single, 3¼ × 23¼ inches inside . . . \$2 00	Double, 6¼ × 23¼ inches inside . . . \$2 50
Single, 3¼ × 11¼ inches inside . . . 1 50	Triple, 8¼ × 23¼ inches inside . . . 3 25
Medium, 5 × 23¼ inches inside . . . 2 25	

ALL-BRASS JOB GALLEYS.

6 × 10 inches inside \$1 50	12 × 18 inches inside \$3 75
8¾ × 13 inches inside 2 00	14 × 21 inches inside 4 50
9 × 14 inches inside 2 50	15 × 22 inches inside 5 00
10 × 16 inches inside 3 00	18 × 25 inches inside 6 00

LINCOLN ALL-BRASS GALLEYS.

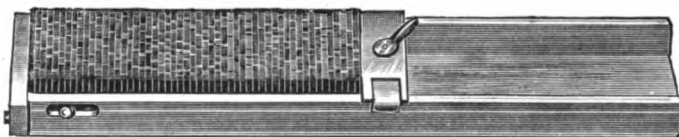

Shows the Galley locked at end and side.

A good galley for newspaper work. *Made to order* to hold any regular widths of matter in regular use in an office. The upper side of galley is strongly hinged to the bottom.

This hinged side is dropped when emptying on galley, and when matter is ready for locking up the side is raised and is held by a spring-catch at head of galley

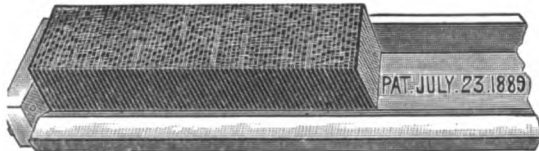

Shows the Galley unlocked, with end lock detached.



and by the end clamp which locks the sides and end at the same operation. The catch is loosened by turning lever to the right. These galleys are about one inch wider than the width of column they are made to take.

12-inch News, all brass \$2 00	24-inch News, all brass \$3 00
16-inch News, all brass 2 50	24-inch Book, all brass 3 50

In ordering, give exact width of columns.

LAING PATENT GALLEY LOCK-UP.

Attachable to all Brass, Smooth Lined, and Patent Lined Gallies.

A satisfactory, simple, effective lock-up. It may be screwed on any galley; the side stick (which is not beveled) is attached to the lock-up, and has a parallel motion. It is locked or unlocked by pushing the lever up or down by means of a finger knob. The lock-up and the side stick are made of brass.



*** COLUMN GALLEYS, WITH LOCK-UP.**

	Price of Galley.	*Price of Lock-up.	Complete.
3 3/4 x 23 3/4 inches inside	\$2 00	\$1 50	\$3 50
3 3/4 x 15 3/4 inches inside	1 75	1 40	3 15
3 3/4 x 11 3/4 inches inside	1 50	1 30	2 80
5 x 23 3/4 inches inside	2 25	1 50	3 75
6 1/4 x 23 3/4 inches inside	2 50	1 50	4 00
6 1/4 x 15 3/4 inches inside	2 25	1 40	3 65
6 1/4 x 11 3/4 inches inside	2 00	1 30	3 30
8 1/4 x 23 3/4 inches inside	3 25	1 50	4 75

*** JOB GALLEYS, WITH LOCK-UP.**

	Price of Galley.	*Price of Lock-up.	Complete.
6 x 10 inches inside	\$1 50	\$1 25	\$2 75
8 1/2 x 13 inches inside	2 00	1 30	3 30
9 x 14 inches inside	2 50	1 35	3 85
10 x 16 inches inside	3 00	1 40	4 40
12 x 18 inches inside	3 75	1 45	5 20
14 x 21 inches inside	4 50	1 50	6 00
15 x 22 inches inside	5 00	1 50	6 50
18 x 25 inches inside	6 00	1 60	7 60

* If Galley Lock-up is sold separately, the necessary screws for attaching to galley are included in prices given.

PATENT LINOTYPE GALLEY.

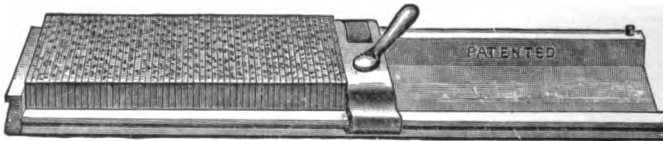

This new patent galley is made solely for linotypes, and is the only galley for holding linotype slugs without any side lock-up. A foot clamp is attached to each galley to hold up the matter in taking proofs. This galley will save all the trouble and the loss of time in handling side sticks, getting quoins to fit, or foot slugs to keep the end line from falling over. One side of the galley is made lower, and the inside of the rims so tapered as to allow inserting and taking out the linotype slugs from the side very readily. The galley being only one-half of an inch wider than the matter, is conveniently handled and can be placed on the stone, rack or case without taking

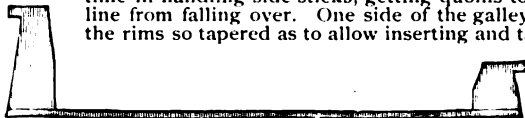

End view, 13 ems wide inside.

up valuable space. On a crowded imposing table, in the rush of making-up, the saving of space is of great importance.

12 inch, all-brass News Galley, for 16 ems or under†	\$2 00
16 inch, all-brass News Galley, for 16 ems or under	2 25
24 inch, all-brass News Galley, for 16 ems or under	2 50
Extra foot clamps, each	0 50

Other sizes made to order. Above prices include foot clamp.

† In ordering, give the measure of column width, as galleys are supplied to take one measure only, not exceeding 16 ems; also send a sample linotype slug.

UNLINED GALLEYS.

ZINC BOTTOM.

Single Column, 3½ × 23¼ inches inside	\$1 25
Double Column, 6¼ × 23¼ inches inside	1 50

BRASS BOTTOM.

Single Column, 3½ × 23¼ inches inside	\$1 50
Double Column, 6¼ × 23¼ inches inside	2 00

CLOSED-END MAILING GALLEYS.

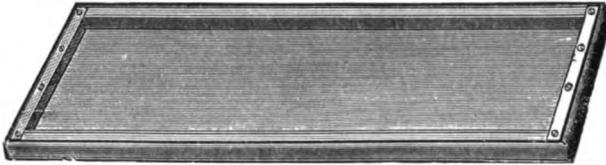

6¼ × 23¼ inches inside, closed ends, all brass, each	\$3 25
7¼ × 23¼ inches inside, closed ends, all brass, each	3 50
6¼ × 22¼ inches inside, closed ends, brass lined, each	3 00
10 × 22¼ inches inside, closed ends, brass lined, each	4 00
2¾ × 24 inches inside, closed ends, brass lined, each	2 25
6¼ × 22¼ closed ends, zinc bottom, unlined, each	1 50

MAILING GALLEYS.



Mustang Mailing Galley.

Mustang Mailing Galley, zinc bottom	\$0 50
Mustang Mailing Galley, brass bottom	0 75



Rukenbrod Mailing Galley.

Rukenbrod Mailing Galley, zinc bottom	\$0 60
Rukenbrod Mailing Galley, brass bottom	0 85

WOODEN GALLEYS.

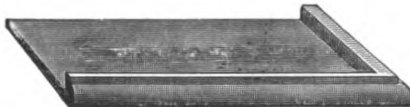

5 × 8 inches inside	\$0 25	8 × 10 inches inside	\$0 40
5 × 15 inches inside	0 30	8 × 24 inches inside	0 60
5½ × 18 inches inside	0 40	10 × 16 inches inside	0 65
6 × 10 inches inside	0 30	9 × 18 inches inside	0 70
6½ × 24 inches inside	0 60	10 × 24 inches inside	0 75
7 × 22 inches inside	0 55	3½ × 24 inches inside	0 50

MOVABLE GALLEY RACKS.

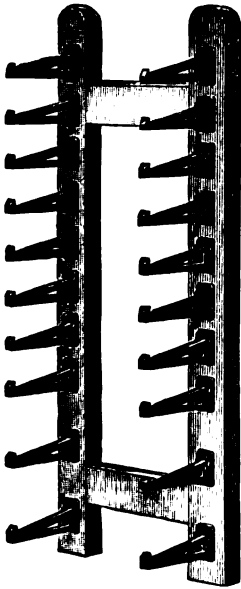

Regular Galley Rack with Movable Galley Brackets.

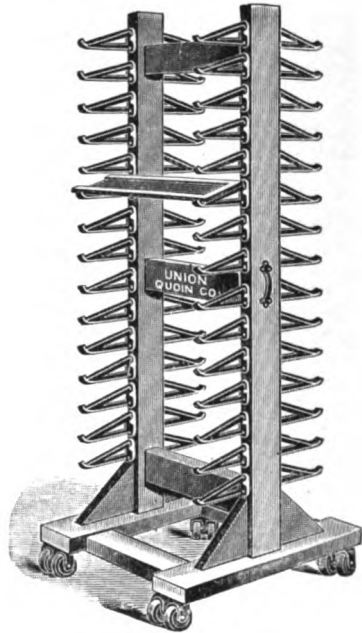

Union Movable Galley Rack.

UNION MOVABLE GALLEY RACK.

The Union Movable Galley Rack holds 30 galleys, and is mounted on strong casters so that it can be moved at will to the most convenient position for doing the work in hand. Union Movable Galley Rack, holding 30 galleys \$21 00

REGULAR GALLEY RACK.

The Regular Galley Rack is intended for placing against the wall. The brackets are secured on a very strong hard-wood frame.

Regular Galley Rack, for 6 galleys	\$ 3 00
Regular Galley Rack, for 8 galleys	4 00
Regular Galley Rack, for 10 galleys	5 00
Regular Galley Rack, for 12 galleys	6 00
Regular Galley Rack, for 15 galleys	7 50
Regular Galley Rack, for 20 galleys	10 00

GALLEY BRACKETS.

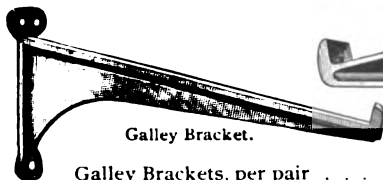

Galley Bracket.

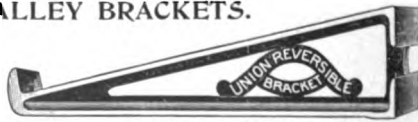

Union Reversible Galley Bracket and Socket.



Galley Brackets, per pair	\$0 40
Union Reversible Galley Brackets, with sockets, per doz. pairs, \$6 00; per pair	0 60

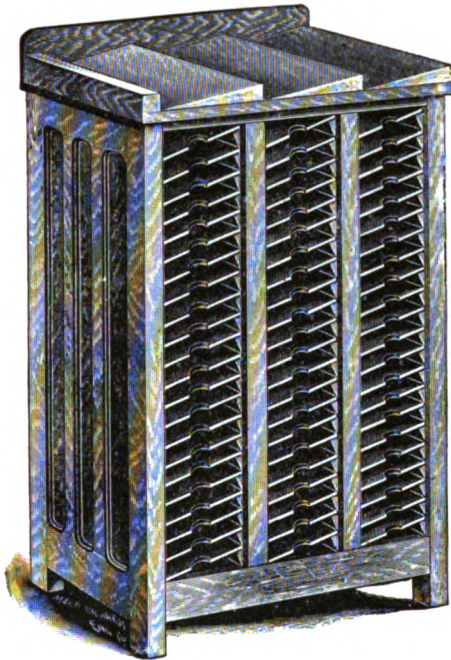

Three-tier Galley Cabinet with Galley Top, to hold Sixty-six Galleys.

GALLEY CABINETS.

Made in Hard Wood, Cherry Finish.

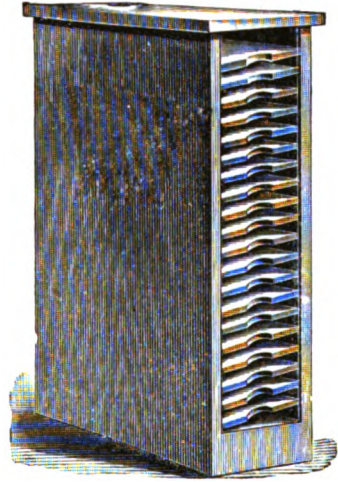

One-tier Flat-top Galley Cabinet, to hold Twenty Galleys.

Particular attention is directed to the Galley Cabinets of larger capacity. They are very desirable in the larger offices, and are designed to carry an immense weight of type safely. All these Cabinets are made of hard wood. All Flat-top Cabinets are made same style as the One-tier Cabinet illustrated above. All Galley-top Cabinets same as the Three-tier Cabinet shown on this page.

The "Galley-top" Cabinets are of much stronger construction than the "Flat-top," and may be ordered with or without galley top, as desired, at the same prices.

	With Flat Top.	With Galley Top.	Boxing.
1 Tier to hold 20 Galleys	\$ 8 00	\$14 00	\$0 50
1 Tier to hold 30 Galleys	11 50	. . .	0 75
2 Tier to hold 40 Galleys	15 00	25 00	1 00
2 Tier to hold 50 Galleys	18 50	. . .	1 25
2 Tier to hold 60 Galleys	22 00	. . .	1 50
3 Tier to hold 66 Galleys	36 00	2 00
4 Tier to hold 88 Galleys	47 50	2 50
6 Tier to hold 132 Galleys	62 00	3 00
9 Tier to hold 198 Galleys	85 00	4 00

NOTE.—The shelves in the larger cabinets should be numbered, and the proof of the galley should be numbered to correspond with the number on shelf, thus saving all the time required to locate galleys that are not so numbered. Iron number plates, made for numbering shelves, can be supplied at the following prices, net: 1 tier (20 galleys), \$1 00; 1 tier (30 galleys), \$1 25; 2 tiers (40 galleys), \$1 50; 2 tiers (50 galleys), \$1 75; 2 tiers (60 galleys), \$2 00; 3 tiers, \$2 25; 4 tiers, \$3 00; 6 tiers, \$4 00; 9 tiers, \$5 00.

HEMPEL IMPROVED QUOIN.

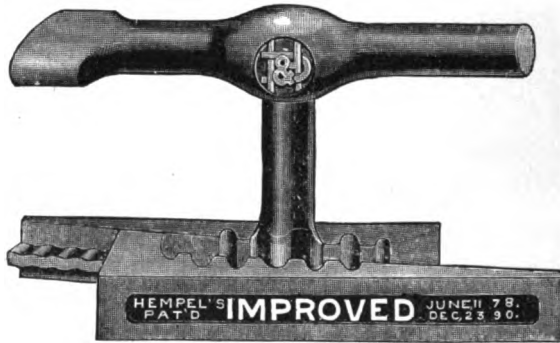

The Hempel Quoins are the standard, tested by time and approved by those who use them. This is the latest improved quoin.

No. 1 small, per dozen pairs	\$2 50
No. 2, large, per dozen pairs	3 00
Keys, each	0 50

IMPROVED BROWER QUOIN.

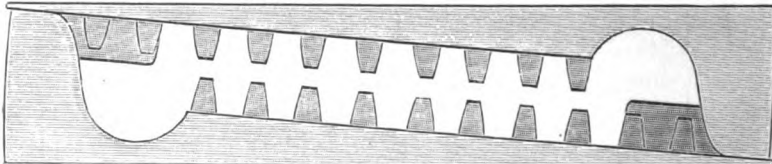

No. 2 Brower Quoin, actual size.

Has central racks, and consequently will not throw type off its feet. Works smoothly. The key, of steel, with cut teeth, has a firmer and deeper hold than in the old style quoin.



No. O. "Little Samson," actual size.

The No. O, as illustrated, is the smallest wedge quoin ever made, and will prove very valuable for job printers and on occasions when lock-up must be made in small spaces.

No. O, smallest wedge quoin made, "Little Samson," per dozen	\$2 00
No. 1, medium size, per dozen	2 50
No. 2, large size, per dozen	3 00
Steel keys, all sizes, each	0 50

	Per Dozen.	Key.
WICKERSHAM QUOIN	\$2 50	\$0 50
PERRY QUOIN	2 50	0 50
CHALLENGE HEMPEL QUOIN, No. 1	2 50	0 50
CHALLENGE HEMPEL QUOIN, No. 2	3 00	0 50

UNION LOCKABLE QUOIN.



An exact duplicate of the original Hempel Quoin, with three notches cut in the central rib for the purpose of using the quoin in connection with the Patent Brower Lock, listed below.

No. 1, small, per dozen \$2 50 | No. 2, large, per dozen \$3 00
 Keys, each \$0 50

BROWER QUOIN LOCK.

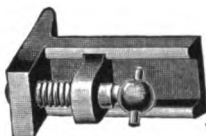

Fig. 2. The Lock.

The sidewise projection shown in Fig. 2 engages in notches cut in central rib of Union Lockable Quoin, or in the rack teeth of the Brower Quoin (see opposite page). The screw is then set up against the other half of the quoin, effectually preventing it from slipping. Quoins of the wedge principle are all liable on long runs to be loosened by the vibrations of the press. These locks make the lock-up doubly sure. They should be applied by the pressman after he has completed the make-ready and before the run is commenced.

No. 0, to fit No. 0 Brower Quoin, per dozen \$2 50
 No. 1, to fit No. 1 Brower Quoin, per dozen 2 75
 No. 2, to fit No. 2 Brower Quoin, per dozen 3 00
 No. 3, to fit No. 1 Union Lockable Quoin, per dozen 2 75
 No. 4, to fit No. 2 Union Lockable Quoin, per dozen 3 00
 Screw-driver, to fasten quoin lock, each 50

MIDGET SAFETY QUOIN.

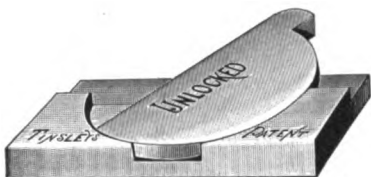

Fig. 3 shows Midget Quoin unlocked.



Fig. 2. This cut shows extreme expansion of six points when locked.

Midget Quoins are made of hard brass. Midget Quoins give a safe lock-up in a width of 18 points. Midget Quoins are useful for locking a form within a form.

It is locked by a tap of a mallet, and occupies no more space in length when locked than when unlocked. Can be used in a space 18 points wide by 120 points long, either outside or inside a form. It is absolutely safe, as when locked it rests against its corresponding flat surfaces, and the harder the surface it bears against the better.

This invaluable quoin may be used to lock up matter inside a brass circle, or oval, or within a solid border, or in places where no other quoin of wood or metal can be used. Fig. 1 illustrates how this quoin is used in a mortised cut.



Fig. 1 illustrates the method of unlocking.

Price, per dozen, with key, net \$2 00

WROUGHT IRON CHASES.

IMPORTANT.—Other sizes made at approximate prices. In ordering, great care must be exercised to send the correct measurements, as all chases are made to order and cannot be taken back. In ordering be careful to state :

- (1) Kind of chase required.
- (2) Inside dimensions of each chase.
- (3) Outside dimensions of each chase, or, in case of twin chases, the pair taken together.
- (4) If twin chases, give width of backs.
- (5) Width of cross-bars, if any.
- (6) Dimensions of bed of press on which chases are to be used.

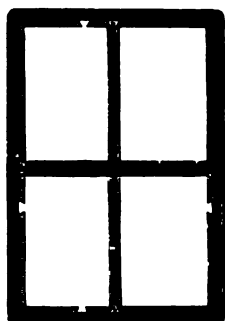

Book Chase.

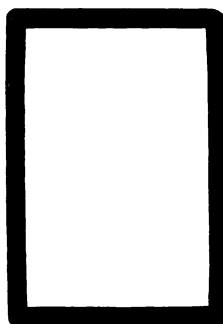

Skeleton or Poster Chase.

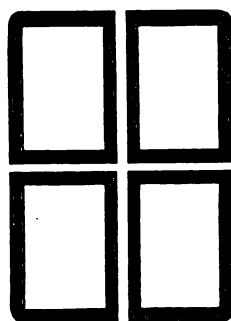

Quadruplex Chases.

BOOK CHASES.

Outside Measure.	Price, each.	Outside Measure.	Price, each.
17×21 inches	\$ 8 00	32×46 inches	\$11 00
20×25 inches	8 50	34×50 inches	12 00
24×30 inches	9 00	36×52 inches	13 00
25×35 inches	9 50	40×54 inches	14 00
29×42 inches	10 00	42×60 inches	15 00

SKELETON OR POSTER CHASES.

Outside Measure.	Price, each.	Outside Measure.	Price, each.
17×21 inches	\$ 4 50	32×46 inches	\$ 8 00
20×25 inches	5 50	34×50 inches	9 00
24×30 inches	6 00	36×52 inches	10 00
25×35 inches	6 50	40×54 inches	11 00
29×42 inches	7 25	42×60 inches	12 00

QUADRUPLEX CHASES.

	Size Outside each.	Prices per Set of Four.
5-Column	14 × 21¼	\$19 00
6-Column	16¼ × 23½	20 00
7-Column	19 × 25¼	22 00

Other sizes made to order.

HEADING CHASES WITH CROSS-BAR.

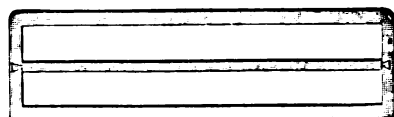

Heading Chase.

Size Inside.	
6×17, Flat Cap	\$5 50
8×21, Demy	6 00
8×28, Double Cap	8 00

These chases are also made with short cross-bars upon special order.

FOLIO OR TWIN CHASES.

	Outside Measure, each half.	Price, per pair.
5-Column Folio	14 × 21 ¼ inches	\$ 9 50
6-Column Folio	16 ½ × 24 inches	10 00
7-Column Folio	19 × 25 ¾ inches	11 00
7-Column Folio wide	20 ½ × 27 inches	12 00
8-Column Folio	21 × 28 inches	13 00
8-Column Folio wide	22 ¼ × 29 inches	14 00
9-Column Folio	23 ½ × 30 ½ inches	15 00
9-Column Folio wide	23 ½ × 32 inches	16 50
10-Column Folio extra	25 ½ × 37 ½ inches	17 50

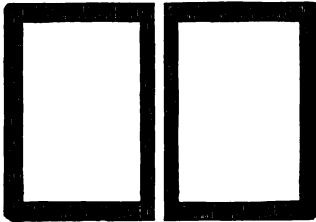

Folio or Twin Chases.

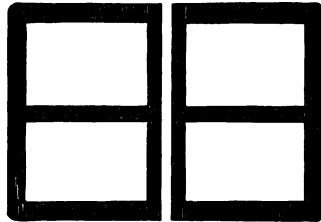

Quarto or Twin Chases with Bars.

QUARTO OR TWIN CHASES WITH BARS.

	Outside Measure, each half.	Price, per pair.
4-Column Quarto	18 × 24 ½ inches	\$14 50
5-Column Quarto	21 ½ × 28 ½ inches	15 50
6-Column Quarto	23 ¾ × 32 ½ inches	16 00
7-Column Quarto	25 ½ × 37 ½ inches	17 50
8-Column Quarto	28 × 42 inches	19 50

WROUGHT IRON CHASES FOR JOB PRESSES.

Made to order only.

Eighth Medium, each	\$4 25	Half Medium, each	\$6 50
Quarto Medium, each	5 50	Half Super-Royal, each	7 25

ELECTROTYPE CHASES.

These have reinforced corners.

Inside.	Rim.	Cast Iron.	Wrought Iron.
10 × 14 inches	¾ × 1 ¼ inches	\$1 75	\$3 75
12 × 18 inches	¾ × 1 ¼ inches	2 00	4 00

CAST IRON CHASES.

These are finished inside.

Outside Measure.	Price.	Outside Measure.	Price.
6 × 7 inches	\$0 45	12 × 14 inches	\$1 20
6 ½ × 8 ¾ inches	0 50	12 × 15 inches	1 30
6 × 18 inches	1 20	12 × 18 inches	1 40
8 × 10 inches	0 80	12 × 26 inches	1 80
9 × 12 inches	1 00	12 × 30 inches	1 90
8 ½ × 14 inches	1 10	12 × 33 inches	2 25
8 × 20 inches	1 30	13 ¾ × 20 ½ inches	1 75
8 × 24 inches	1 40	14 × 16 inches	1 40
8 × 28 inches	1 60	14 × 18 inches	1 75
10 × 14 inches	1 20	14 ¾ × 19 ¼ inches	1 80
10 × 24 inches	1 50	15 × 24 inches	2 00
10 × 25 ½ inches	1 65	16 × 19 inches	1 90
10 × 28 inches	1 75	17 × 22 inches	1 75
11 × 16 inches	1 30	17 × 22 inches, with cross bar	2 25
10 ½ × 14 ½ inches	1 25		

CHASES FOR C. & P. GORDON PRESSES.

Outside Measure.	Cast Iron.	Cast Iron Screw.	Steel.	Steel Screw.
7 × 11 inches	\$1 00	\$1 50	\$2 70	\$4 00
8 × 12 inches	1 25	1 90	3 00	4 50
10 × 15 inches	1 50	2 25	4 50	6 75
12 × 18 inches	2 00	3 00	5 25	8 00
14 × 20 inches	2 50	3 75	5 75	8 50
14½ × 22 inches	3 00	4 50	6 00	9 00

CHASES FOR GALLY UNIVERSAL PRESSES.

	For 10 × 15 Press.	For 13 × 19 Press.	For 14 × 22 Press.
Cast iron	\$2 00	\$2 25	\$2 75
Wrought iron	5 50	6 50	7 25
*Steel skeleton	5 50	6 50	7 25

* Steel skeleton chases give more lock-up room, but do not add to printing capacity of press.

CHASES FOR PEERLESS PRESSES.

	For 8 × 12 Press.	For 9 × 13 Press.	For 10 × 15 Press.	For 11 × 17 Press.	For 14 × 20 Press.	For 14½ × 22 Press.
Cast iron	\$1 50	\$1 50	\$2 00	\$2 00	\$2 75	\$3 00

IRON SIDE AND FOOT STICKS.



In ordering be careful to state whether straight or beveled side and foot sticks are wanted.

Straight Iron Side or Foot Sticks, any length, per inch	\$0 04
Beveled Iron Side or Foot Sticks, any length, per inch	0 05

IRON SIDE STICKS.

	Straight.	Beveled.
15 inches long for 4-Column Folio or Quarto, each	\$0 60	\$0 75
19 inches long for 5-Column Folio or Quarto, each	0 75	0 95
21 inches long for 6-Column Folio or Quarto, each	0 85	1 05
23 inches long for 7-Column Folio or Quarto, each	0 95	1 15
25 inches long for 8-Column Folio, each	1 00	1 25
27 inches long for 9-Column Folio, each	1 10	1 35

IRON FOOT STICKS.

	Straight.	Beveled.
8¾ inches long for 4-Column Folio or Quarto, each	\$0 35	\$0 45
11¼ inches long for 5-Column Folio or Quarto, each	0 45	0 60
13¾ inches long for 6-Column Folio or Quarto, each	0 55	0 70
15¾ inches long for 7-Column Folio or Quarto, each	0 65	0 80
18 inches long for 8-Column Folio, each	0 75	0 90
20½ inches long for 9-Column Folio, each	0 85	1 05

FORM TRUCK.

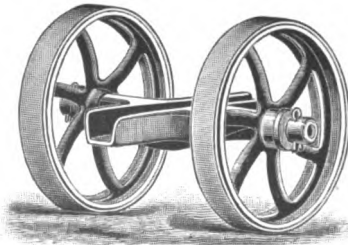

Both the Form Trucks listed below are of malleable iron. The Union Form Truck is painted red.

The use of a form truck should be insisted on in every press room of any size, not only because it is a time saver, but because sliding chases along the floor is a source of frequent accidents.

Iron tire	\$3 00
Union Form Truck, with rubber tire	5 00

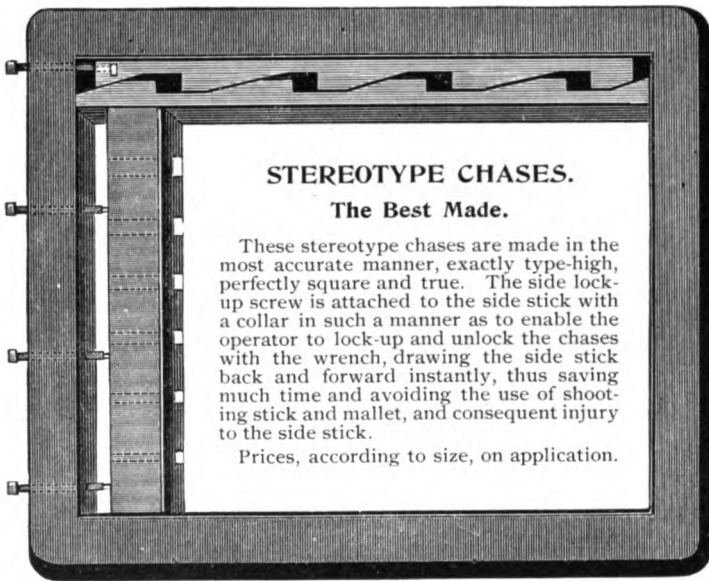

STEREOTYPE CHASES.
The Best Made.

These stereotype chases are made in the most accurate manner, exactly type-high, perfectly square and true. The side lock-up screw is attached to the side stick with a collar in such a manner as to enable the operator to lock-up and unlock the chases with the wrench, drawing the side stick back and forward instantly, thus saving much time and avoiding the use of shooting stick and mallet, and consequent injury to the side stick.

Prices, according to size, on application.

Lock-up Wrenches for Stereotype Chases Price, \$2 50

MAKE-UP TABLES.

These tables are used for making-up and carrying forms either to the beating table or matrix-rolling machine (or elevator, if the stereotype room is not on the same floor with the composing room), and are very substantially built of hard wood with patent double-roller revolving casters. The iron top is either smoothed off or covered with brass—the latter being preferred by the leading newspaper offices.



Size of Matter.	Price, Iron Top.	Price, Top Covered with Brass.
15 x 20 inches . . .	\$40 00	\$50 00
18 x 24 inches . . .	50 00	60 00
21 x 28 inches . . .	55 00	65 00
24 x 32 inches . . .	65 00	75 00

IRON-TOP BEATING TABLES.

For Paper Process.

Size of Matter.	Price, Fixed Top.	Price, Elevating Top.	Size of Matter.	Price, Fixed Top.	Price, Elevating Top.
15 x 20 inches	\$40 00	\$75 00	21 x 28 inches	\$55 00	\$105 00
18 x 24 inches	50 00	95 00	24 x 32 inches	65 00	125 00

IMPOSING TABLES AND MARBLE STONES.



Square-leg Imposing Table.

Square-leg imposing tables are made of hard wood, varnished and bolted together. Round-leg imposing tables are made of hard wood, cherry finish, and are bolted together. Tables over six feet in length have six legs (see illustration below). The larger tables have two drawers, one at each end, and the smaller one drawer, which pulls out both sides. —A "coffin" is a hard wood frame which serves as a bed for the stone, protects its edges, and affords a rest for galleys when used for sliding off matter.

	Imposing Stone only.	Imposing Stone in Coffin.	Round-leg Table and Stone.	Square-leg Table and Stone.
For 6-Column paper, 2 pages 24 x 36 inches . . .	\$ 6 00	\$ 7 75	\$18 75	\$15 00
For 7-Column paper, 2 pages 26 x 44 inches . . .	8 00	10 00	22 00	18 00
For 8-Column paper, 2 pages 28 x 50 inches . . .	10 00	12 50	26 50	21 50
For 9-Column paper, 2 pages 32 x 60 inches . . .	12 50	15 50	30 00	25 50
For 7-Column paper, 4 pages 26 x 76 inches . . .	13 75	17 25	32 25	27 00
For 8-Column paper, 4 pages 28 x 80 inches . . .	15 50	19 50	37 00	32 00
For 9-Column paper, 4 pages 30 x 90 inches . . .	18 75	23 50	43 50	38 00
For 6-Column quarto, 4 pages 36 x 60 inches . . .	15 00	18 50	37 00	32 00
For 7-Column quarto, 4 pages 48 x 60 inches . . .	20 00	25 00	45 50	40 00

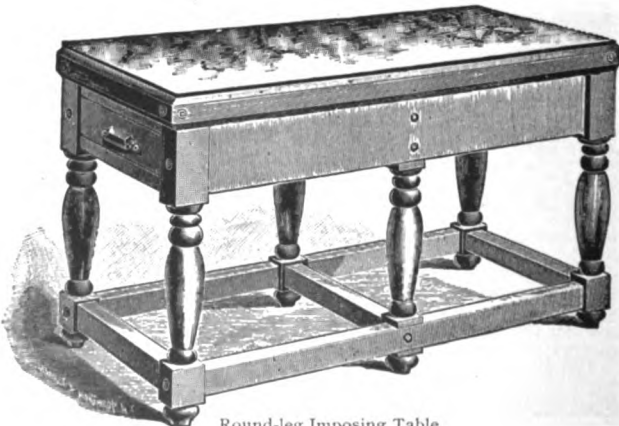

Round-leg Imposing Table.

IMPOSING TABLES WITH LETTER BOARDS.

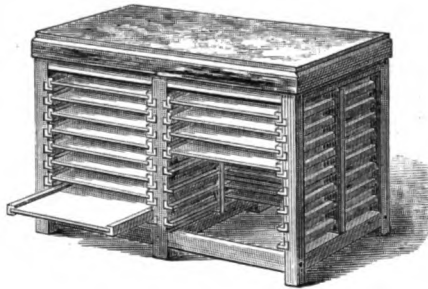

No. 9. With 36x60-inch Marble Top; has thirty-two Letter Boards, each 17½ x 26 inches inside.

No better disposition of the space underneath an imposing table can be made than to use it for letter boards. If the type is dead, it is shifted from the stone to the board without loss of time; if the matter is alive, it is handy for imposition.

These tables are made in the most substantial manner, of hard wood, varnished, and strongly and firmly bolted together. The boards are made of hard wood, closed at sides and back, and are rabbeted in front to receive galley when sliding off type.

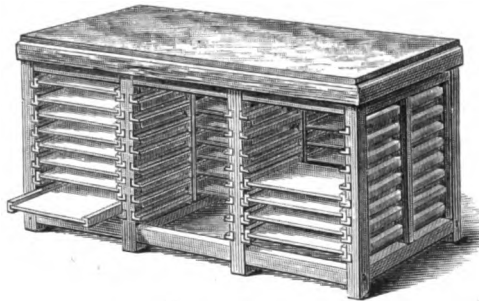

No. 10. With 40x80-inch Marble Top; has 48 Letter Boards, each 19½ x 22½ inches inside.

Prices with Hard Marble Stones.

	Number of Boards.	Size of Stone.	Size of Boards.	Without Boards.	Boards each.	Complete with Boards.
No. 2	10	24x36	22 x 32	\$40 00
No. 3	10	32x48	30 x 44	60 00
No. 9	32	36x60	17½ x 26	\$42 50	\$1 00	72 50
No. 10	48	40x80	19½ x 22½	55 00	0 90	95 50

IRON IMPOSING SURFACES

Supplied any size to order 2½ cents per square inch.

MARBLE INK SLABS.

8x12 inches	\$1 25
12x18 inches	2 00
18x24 inches	3 75

WOOD FURNITURE, REGLET AND SIDE STICKS.

	Per yard.		Per yard.
Pearl to Pica Reglet	\$0 02	6- to 9-line Furniture	\$0 06
Gr. Primer Reglet to 2-line Furniture	0 03	10- to 12-line Furniture	0 08
3- to 5-line Furniture	0 04	13- to 16-line Furniture	0 10

SIDE STICKS, thin, medium or thick Per yard, \$0 06

WOODEN QUOINS.

	Boxes of	Burlap Bags	Burlap Bags
	100.	of 500.	of 1000.
Hickory	\$0 40	\$1 80	\$3 50
Boxwood	0 60	2 70	5 25
Hickory, in barrels, containing about 7000, per 1000			3 25
Boxwood, in barrels, containing about 7000, per 1000			5 00

LABOR-SAVING REGLET CASES.

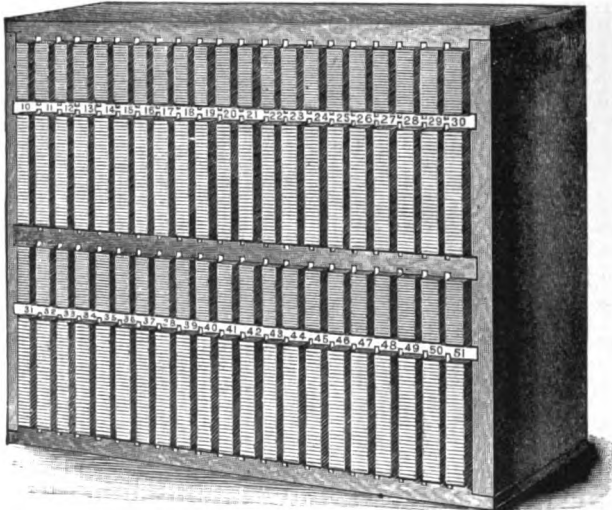

Reglet Case No. 4. 2100 pieces, \$8 00.

Nos. 3, 4, 5, 6 are made same style as above illustration. The reglet lies flat, and varies by ems up to 51 ems, and by 5 ems in longer lengths. Nos. 1 and 2 are square boxes, in which reglet is put in on end, and varies by 10 ems up to 60 ems, with 72 and 120 ems added in the No. 2 case. One-half the pieces in each case are Pica body; the other half, Nonpareil body.

Case.	No. of Pieces.	No. of Yards.	Lengths in Case.	Price.
No. 1	1800	300	10 to 60 ems.	\$ 8 00
No. 2	2400	600	10 to 120 ems.	14 00
No. 3	4200	550	10 to 51 ems.	15 00
No. 4	2100	275	10 to 51 ems.	8 00
No. 5	6300	1500	10 to 150 ems.	38 00
No. 6	3150	750	10 to 150 ems.	20 00

LABOR-SAVING FURNITURE, WITHOUT CASES.

Half Font of 280 pieces, in a box	\$2 75
Single Font of 560 pieces, in a box	5 00
Double Font of 1120 pieces, in a box	10 00

LABOR-SAVING FURNITURE.

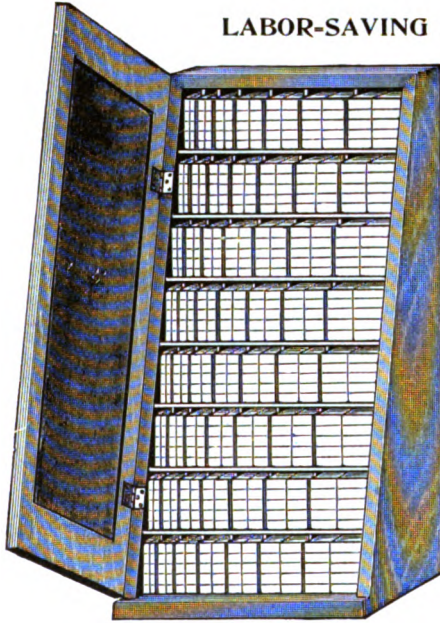

No. 3. Single Case, with Partitions and Door.

This Labor-Saving Furniture is thoroughly oiled, and cut to the Point standard. Every piece has the size stamped on the end.

Cases are made *with* or *without* partitions. The usefulness of the font is doubled by having it in a case with partitions.

A single case contains 560 pieces, divided into 10 pieces, each 10, 15, 20, 25, 30, 40, 50 and 60 ems long by 2, 3, 4, 5, 6, 8 and 10 ems wide.

A Half Case contains half the number of pieces held in a Single Case.

THE No. 7 MAMMOTH CASE

Is especially designed for large offices, and contains the following assortment of selected furniture, from 10 to 160 ems long: 270 pieces each 2-line, 3-line and 4-line furniture; 225 pieces each 5-line and 6-line furniture; 135 pieces each 8-line and 10-line furniture—assorted in 10, 15, 20, 25, 30, 40, 50, 60, 70, 80, 90, 100, 120, 140 and 160 ems lengths. There is a larger proportion of the narrower and most-used sizes than of the wide furniture.

- No. 1. Half Case contains 280 pieces, with partitions . . . \$ 6 00
- No. 2. Half Case contains 280 pieces, without partitions . . . 5 00
- No. 3. Single Case contains 560 pieces, with partitions . . . 10 00
- No. 4. Single Case contains 560 pieces, without partitions . . . 8 00
- No. 5. Double Case contains 1120 pieces, with partitions . . . 18 00
- No. 6. Double Case contains 1120 pieces, without partitions . . . 15 00
- No. 7. Mammoth Case, designed for large offices, with partitions, no door (see description above) . . . 40 00

No. 7. Mammoth Case, designed for large offices, with partitions, no door (see description above)

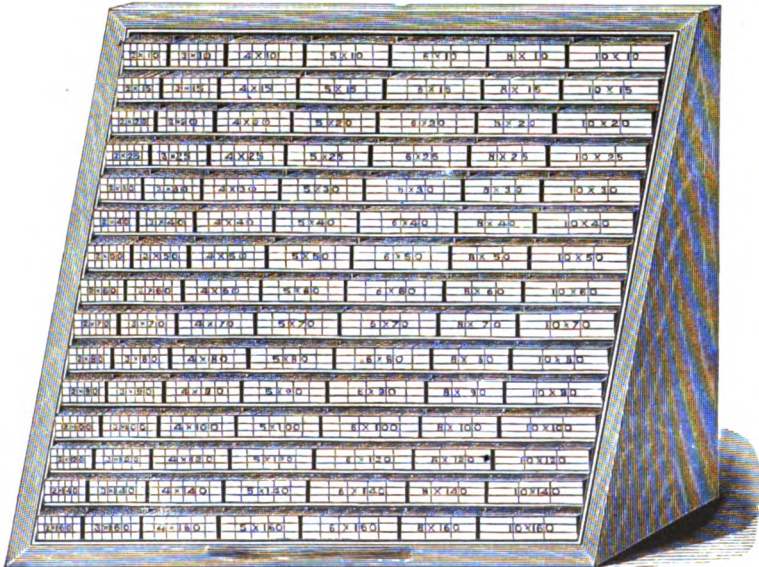

No. 7. Mammoth Labor-Saving Furniture Case.

LABOR-SAVING LEAD RACKS.

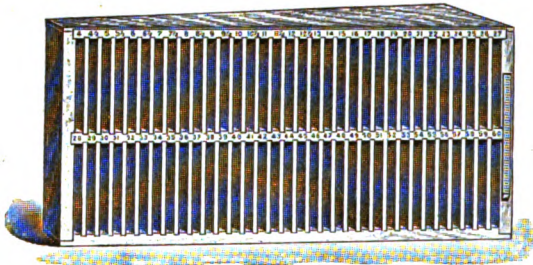

Two-tier Wisconsin Lead Rack ; 4 to 12½ by ems,
13 to 60 by ems.

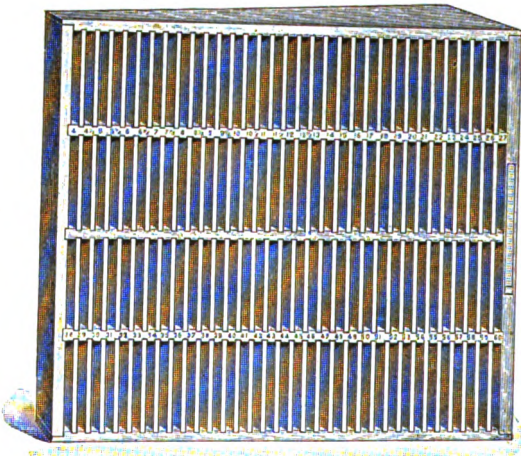

Four-tier Wisconsin Lead Rack ; 4 to 12½ by ems,
13 to 60 by ems twice.

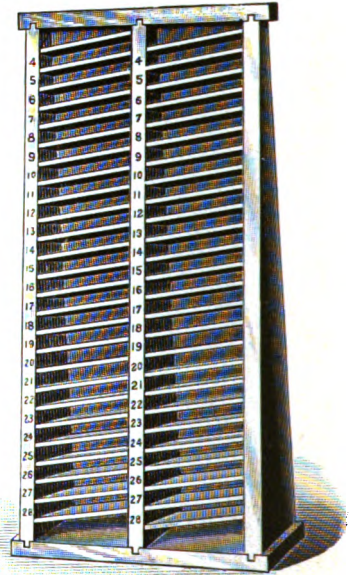

Eureka Lead Rack.

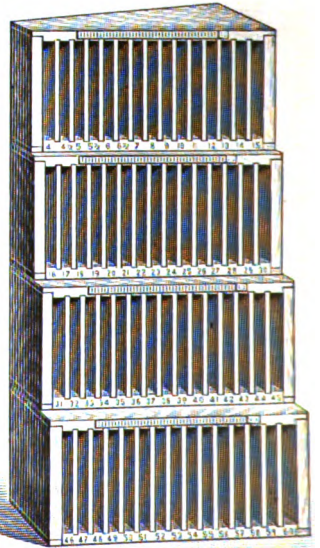

Boston Lead Racks.

PRICES.

Two-tier Wisconsin Lead Rack \$6 00

Takes leads from 4 to 12½ ems (varying by ems), and from 13 to 60 ems (varying by ems), the length being stamped over each compartment. Compartments are eight inches high. Will hold 750 pounds of leads and slugs.

Four-tier Wisconsin Lead Rack \$9 00

Has two compartments each for all sizes in the two-tier rack, and is similar in design and construction. Will hold 1500 pounds of leads and slugs.

Eureka Lead Rack \$2 50

Boston Lead Racks, set of four \$5 40

- No. 1 holds 4 to 15 ems lengths \$0 90
- No. 2 holds 16 to 30 ems lengths 1 20
- No. 3 holds 31 to 45 ems lengths 1 50
- No. 4 holds 46 to 60 ems lengths 1 80

HANDY LETTER BOARD CABINETS.

These very useful cabinets have recently been improved by putting extensions at the back of each board, so that the board may be pulled out to the limit of its inside measurement, and still be held securely between the runs.

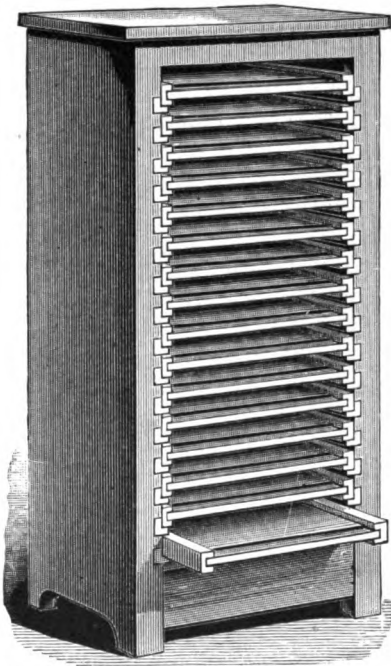

Handy Letter Board Cabinet with Sixteen Boards.

For the storage and safe keeping of job work these cabinets are unrivaled. Their cost will be saved in a few months by the prevention of pi. They occupy a floor space of 16×19 inches, with letter boards of 12×15 inches inside, and are made of hard wood throughout, in a solid and substantial manner. Boards are closed at sides and back, and are rabbeted in front to receive galleys. They are well-named "Handy." For job work within their size—and this the larger variety of such work—these small boards are much superior to the larger boards usually put under imposing tables, as it is a back-breaking job to get a form from these large boards when they are full of type.

It is distinctly an economy to place dead and live forms in such a receptacle as this, rather than to incumber useful space on an imposing stone, the type on which is always liable to damage. The protection they afford from dust is also worthy of consideration.

With 10 boards	\$10 50
With 12 boards	12 00
With 16 boards	15 00

Other sizes made to order at proportionate prices.

HARD-WOOD LETTER BOARDS, TO FIT CASE STANDS.

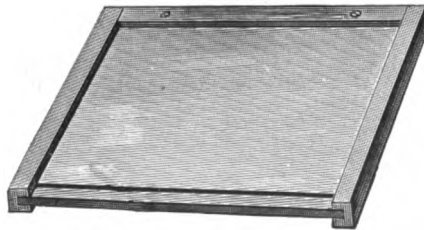

Made of selected stock, smooth and true, with closed sides and backs, rabbeted in front to allow matter to slide on galleys easily. These boards have projecting backs (not shown in cut), so that they can be pulled out of the racks to the full extent of their inside measurements.

No. 1 fits two-third case stands; No. 2, three-quarter stands, and No. 3, full-size stands or racks.

No. 1, 21 ¼ × 20 ½ inches outside	\$1 20
No. 2, 26 ¼ × 20 ½ inches outside	1 40
No. 3, 32 ¼ × 20 ½ inches outside	1 70

PRICE LIST OF CASES.

For illustrations of Cases, see pages 848 and 849.

PATENT NEW DEPARTURE TYPE CASES.

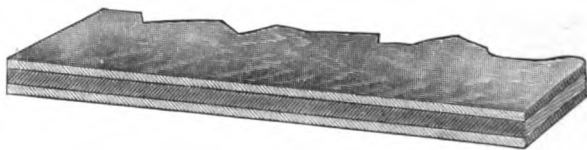

Shows three-ply case bottom, which will not warp nor crack.

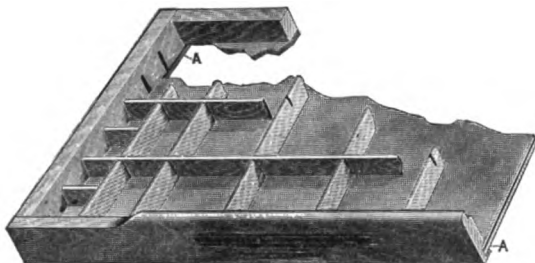

Shows at AA how the three-ply bottoms are set into the front and side rails, so that the case slides on the rails instead of on the case bottoms.

Our cases all have patent "New Departure" three-ply bottoms, which prevent splitting, warping and shrinking. These bottoms are set into the side and front rails (see AA), so that the case slides on the side rails. As the grain of the side rails and of the case-runs in stands and cabinets run the same way, the cases slide much easier and with considerable less wear and tear.

FULL-SIZE CASES.

Size, 32¼ × 16 inches.

	Clasp Cases.	Ordinary Cases.
News Cases, per pair	\$1 75	\$1 60
Cap Case	0 88	0 80
German News Cases, per pair	1 60	1 60
Italic or Job Case	1 00	0 90
California Job Case (see cut page 848)	1 00	0 90
Yankee Job Case—32 cap boxes—(see cut page 849)		1 00
Improved Job Case (see cut page 848)		1 20
Paterson Job Case (see cut page 848)		1 00
New York Job Case (see cut page 848)		1 00
Triple Case	1 00	0 90
Double Lower Case (see cut page 848)		1 20
Rule Case		1 15
Space and Quad Case (see cut page 849)		1 00
Lead and Slug Case		1 00
Border Case		1 25
Figure Case		1 00
Metal Furniture Case (double depth), takes three layers of Furniture (see cut page 849)		2 00
Metal Furniture Case (single depth), takes two layers of Furniture (see cut page 849)		1 50
Blank Case		0 65
Wood Type No. 1 or Script Case, with bars (see page 849)		0 90

See also *Special Wood-Type Cases* listed on next page.

THREE-QUARTER CASES.

Size, 26¼ × 16 inches.

News Cases, per pair	\$1 60	\$1 50
Cap Case	0 85	0 75
Italic or Job Case	0 90	0 80
California Job Case (see cut page 848)	0 90	0 80
Yankee Job Case—32 cap boxes—(see cut page 849)		0 85
Triple Case		0 80
Blank Case		0 60

TWO-THIRD CASES.

Size, 21¼ × 16 inches.

	Ordinary Cases.
New Cases, per pair	\$1 40
Job Case (thirty-two cap boxes)	0 75
Yankee Job Case (twenty-eight cap boxes)	0 75
Lead and Slug Case	0 75
Brass Leader Case	0 75
Script Case	0 75
Improved Job Case (19¼ inches deep). Is deeper than the regular case, and has additional boxes for small caps	0 90
Border Case	0 90
Blank Case	0 45

ROOKER CASES.

A popular size for newspaper offices. Furnished to order only. Size, 28½ × 14 inches.

	Patent Clasps.
News Cases, per pair	\$1 75
Italic or Job Case	1 00

SPECIAL CASES.

	Ordinary Cases.
Wood-Type Case No. 1 (16 × 32¼ inches)	\$0 90
Wood-Type Case No. 2 (23 × 32¼ inches)	1 00
Mammoth Wood-Type Case No. 3 (23 × 44 inches)	1 30
Wisconsin Combination "Quarter" Cases, Nos. A, B, C, D, for holding piece fractions, signs, fractions, figures and borders (see cut page 846), each	0 65

RULE CASES.

Regular Rule Case, full-size	\$1 15
Regular Rule Case, two-third size	0 90
Compact Rule Case. Four of them fit in a full-size blank case (see page 847), each	0 90
* Harris Rule Case, No. 1, holds two 8-pound fonts	1 25
* Harris Rule Case, No. 2, holds one 16-pound font	1 00
* Harris Rule Case, No. 3, } used together, hold one 32-pound font	1 00
* Harris Rule Case, No. 4, }	1 00
Full-size Blank Case, to hold four Harris Rule Cases	0 65

* See cut and description, page 847.

PATENT CLASP CASES.

These cases are of unusual strength, owing to the use of a brass clasp over the corner of each box and a long pin which is driven through center of each clasp and clinched, holding the partitions firmly to the bottom of the case. This feature, in combination with our "New Departure" case bottoms, makes these cases the strongest and most durable, especially for body type and in newspaper offices.

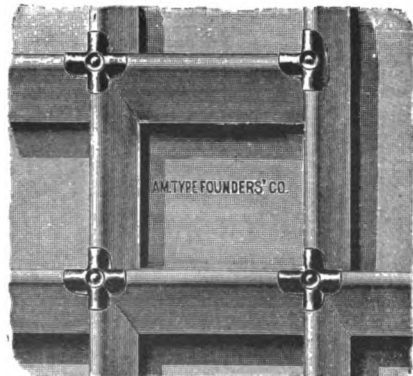

Section of Patent Clasp Case.



INDIVIDUAL LEAD OR RULE CASE.

In this a compositor may keep his much valued 12-to-Pica and other thicknesses of leads for justifying purposes, his pickups of dashes, rule, etc. The case can be kept in his drawer or on his galley rest. It has boxes from 1 to 9½ ems (varying by ems), from 10 to 22 ems (varying by ems), and from 22 to 28 ems (varying by two ems), with a long box for longer lengths. It is also useful for holding a small font of labor-saving brass rule.

Each, 7×7½ inches over all \$o 75

Four of them fit inside a Full-sized Blank Case.

LEADER BOX.

The handiest receptacle for leaders. Can be put on a cap case, on a stone, or on a galley rest, bringing leaders close to hand. One or more required in every office for every size of body type used.

Each, 5×8×1¼ inches over all . . . \$o 25
Per dozen 2 50

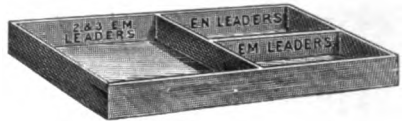

WISCONSIN COMBINATION "QUARTER" CASES.

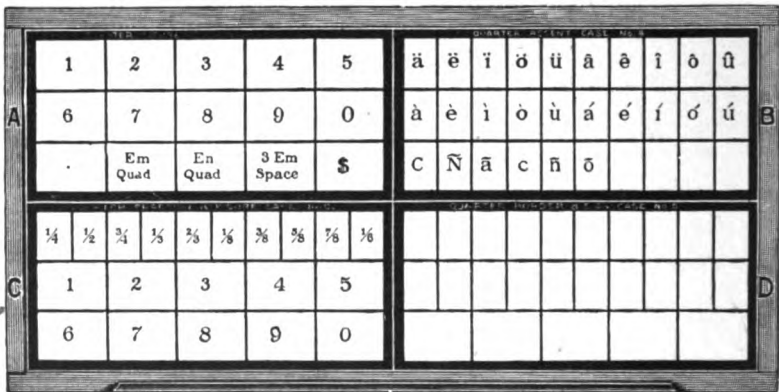

Shows four "Quarter" Cases in Full-size Blank Case.

Signs, Borders, Accents, Split Fractions, although most expensive, are usually stowed away in odd boxes of cap cases, and are rarely to be found when needed. "Quarter" Cases supply a means of keeping these valuable sorts where they can be found. They can be placed on a cap case, on a stand, or on the stone, convenient to hand of compositor. In setting mathematical work, foreign languages, dictionaries, and special catalogues, these "Quarter" Cases will prove invaluable. We show a few schemes for laying signs, fractions, etc., but various other uses for special purposes will suggest themselves to the "intelligent compositor."



For Split Fractions and Commercial Signs.



For Algebraic and Medical Signs.

Quarter Case No. A, for Figures, etc. \$o 65
 Quarter Case No. B, for Accents, Split Fractions, etc. o 65
 Quarter Case No. C, for Figures, Fractions, etc. o 65
 Quarter Case No. D, for Signs, Borders, etc. o 65
 Per set of four, in regular Full-size Blank Case 3 25

HARRIS RULE CASES.

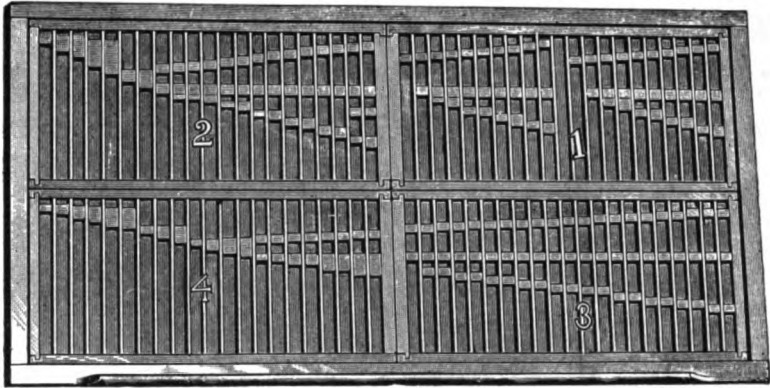

Four Harris Rule Cases in a Full-size Blank Case. Price, \$4 90.

In HARRIS RULE CASES the rule cannot fall flat—must always stay on end. Pi is prevented, because each box is accurately adjusted for its special size—for instance, a 21-em rule will not go into the 20-em rule box. Generous provision is made for the smaller sizes—the most valuable sizes in a labor-saving font. The cases may be used in sets or separately, as Nos. 1 and 2 are complete in themselves. Four of them fit into a full-size blank case.

The rule referred to below is 2-point, which is the most used.

No. 1 Harris Rule Case holds two complete small fonts of Labor Saving Rule, each weighing 8 pounds, or 16 pounds in all. Each half of this case holds eighteen pieces each length from 1 to 8½ ems (varying by ems), and eighteen pieces each from 9 to 18 ems (varying by ems) and nine pieces each 19, 20, 21, 22, 24, 26 and 28 ems, besides boxes for right and left miters.

No. 2 Harris Rule Case holds one complete font of 16 pounds weight or less. It has compartments for thirty-six pieces each from 1 to 9 ems long (varying by ems), eighteen pieces each from 10 to 24 ems long (varying by ems), and eighteen pieces each of 26, 28, 30, 32, 34, 36 ems long, besides boxes for right and left miters. A large proportion of small lengths allowed for.

Nos. 3 and 4 Harris Rule Cases are designed to be used together to hold a font of rule suitable for a large office, weighing 32 pounds or less. Two and in some cases four boxes are used to hold the most-used sizes. Each case has its proportion of the small sizes, so that if it is desired to carry one case to a compositor's stand for use in rule work, the other is available in its regular place with a good working font. These cases have compartments for seventy-two pieces each from 1 to 9 ems long (varying by ems), thirty-six pieces each from 10 to 24 ems long (varying by ems), and eighteen pieces each from 25 to 36 ems long (varying by ems), and boxes for right and left miters.

Harris Rule Case No. 1, holds two 8-pound fonts	\$1 25
Harris Rule Case No. 2, holds one 16-pound font	1 00
Harris Rule Case No. 3, } used together, hold one 32-pound font {	1 00
Harris Rule Case No. 4, }	1 00
Full-size Blank Case, to hold four of above	0 65

COMPACT RULE CASE.

Has compartments for brass rule from 1 to 36 ems Pica, and from 1½ to 9½ ems Pica, with places for miters. Size outside, 7½ x 15¼ inches. Four fit in a full-size blank case. For Full-size Rule Cases see page 845.

Price \$0 90

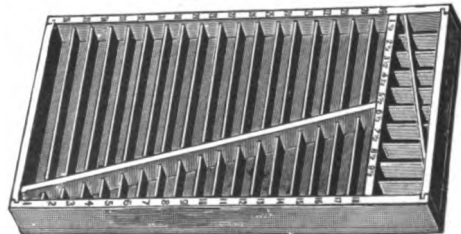

ILLUSTRATIONS OF CASES.

It is unnecessary to illustrate the most-used styles of cases. Nearly all the cases illustrated here have exceptional merit.

CALIFORNIA JOB CASE.

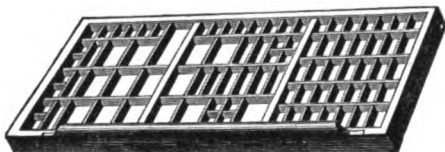

Has fourteen boxes less on cap side than the regular Italic Job Case, thus giving more space for the cap alphabet. A more satisfactory case for the ordinary job font than the Italic Job Case, especially in three-quarter size.

Full-size \$0 90
 Three-quarter 0 80

IMPROVED JOB CASE.

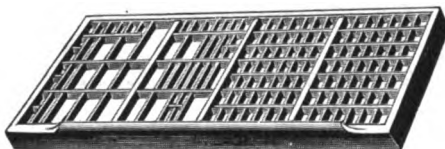

Holds caps, small caps, lower case and figures, or a cap and lower-case font (with figures) and an extra cap font. Will also hold three cap fonts, all with figures. Made full-size only.

Price \$1 20

NEW YORK JOB CASE.

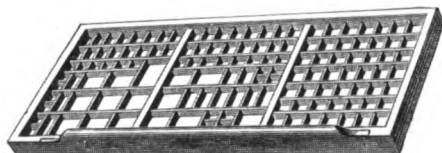

Holds caps, small caps, lower case and figures. The small caps are placed on the same side as the lower-case boxes, and above them. The lower-case boxes are therefore smaller than in a California Job Case. Made full-size only.

Price \$1 00

PATERSON JOB CASE.

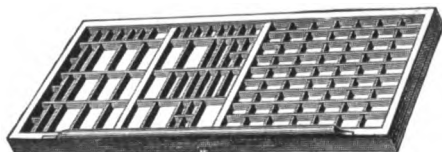

Holds caps, small caps, lower case and figures. The small caps are placed above the cap boxes, all of which are widened, thereby reducing the sizes of the lower-case boxes. A very useful case. Made full-size only.

Price \$1 00

DOUBLE LOWER CASE.

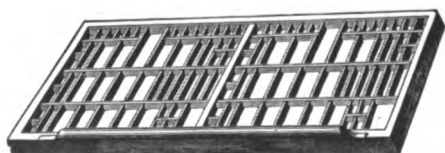

A most useful case. In most job fonts the caps occupy as much space as the lower case, while ordinary job cases give the caps one-half the room allotted the lower-case. In this case the space is divided equally between the caps and lower case. Made full-size only.

Price \$1 20

ROOKER CAP CASE.

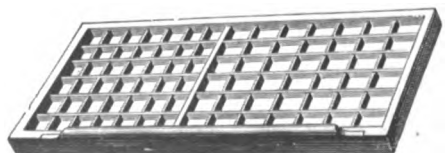

Made only in Rooker size (28 1/4 x 14 1/2). Gives more space for caps and less for small caps than the regular cap case. Rooker cases are two inches narrower than ordinary cases, and cannot be used on the same stands.

Price \$0 88

ILLUSTRATIONS OF CASES.

YANKEE JOB CASE.

In two-third size, a case with cap boxes at the back is a necessity, but in full-size and three-quarter size this case is inferior in utility to other job cases.

- Full-size (32 cap boxes) \$1 00
- Three-quarter (32 cap boxes) 0 85
- Two-third (28 cap boxes) 0 75

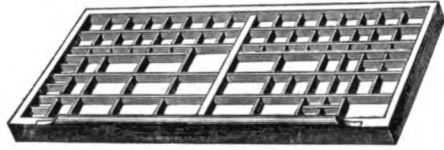

SPACE AND QUAD CASE.

This is an absolutely essential case in offices where economy of time and material is a consideration. Each case holds eight sizes of spaces and quads. Made full-size only.

- Price \$1 00

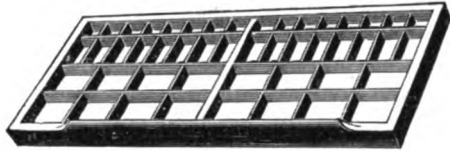

METAL FURNITURE CASE.

A handy receptacle for metal furniture. There are compartments for 1, 2, 3, 4, 5, 6, 8, 10, 15, 20, 25 and 50 ems. The double-depth case takes three layers of furniture; the single-depth case takes two layers. The latter can be put in a full-size case stand or rack, and the double-depth case is for use on top of a stand or cabinet, or a special place can be made for it under the stone. Made full-size only.

- Double-depth \$2 00
- Single-depth 1 50

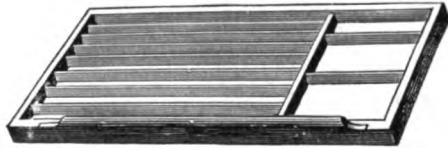

SCRIPT OR WOOD-TYPE CASE.

Although mostly sold for wood type, these cases are made so accurately as to be suitable for large Script fonts. The movable partitions are adjustable by Picas. Nothing injures expensive Script type so much as tumbling about in a case. The use of Script cases will save type. Made in full- and two-third sizes.

- Full-size \$0 90
- Two-third size 0 75

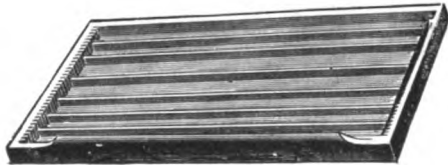

MAMMOTH WOOD-TYPE CASE.

No. 3 (Mammoth) Wood-Type Case, 23 x 44 inches, with slotted sides. For special rack to hold this size case, see page 851. There are two more sizes of Wood-Type Cases made. For prices see page 845.

- Price of No. 3 Wood-Type Case \$1 30

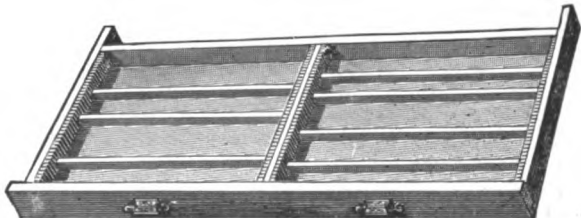

CASE STANDS.

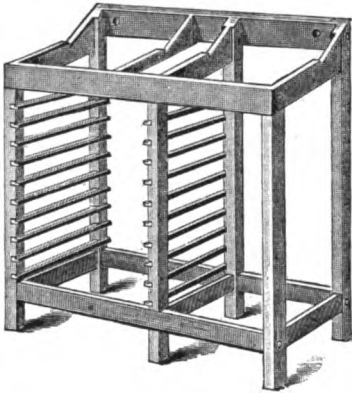

No. 6. Double News Stand, with Eight Racks.

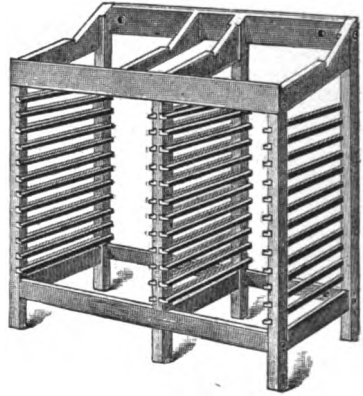

No. 11. Double Job Stand, with Racks for Twelve Full-size and Twelve Two-third Cases.

PRICE LIST OF CASE STANDS.

No. 1. Single, without racks	\$2 75
No. 2. Single, with racks for 12 two-third cases	3 00
No. 2½ Single, with racks for 12 three-quarter cases	3 00
No. 4. Single, with racks for 12 full-size cases	3 25
No. 6. Double News, with racks for 8 full-size cases (see illustration)	3 75
No. 8. Double News, with racks for 12 full-size cases	4 75
No. 11. Double Job Stand, with racks for 12 full-size and 12 two-third cases (see illustration)	5 50
No. 12. Double Job Stand, with racks for 12 full-size and 12 three-quarter cases	5 75
No. 15. Double Stand, with Galley Rest, and racks for 24 full-size cases (see illustration)	6 00
No. 17. Double City Stand, with racks for 30 full-size cases (see illustration)	9 50

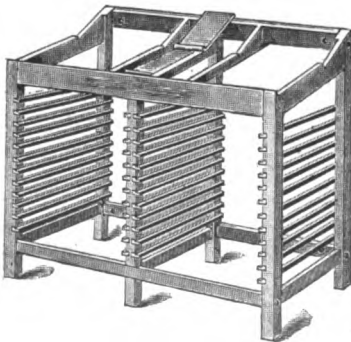

No. 15. Double Stand, with Galley Rest, and Racks for Twenty-four Full-size Cases.

These stands are made of hard wood, with bolted frames.

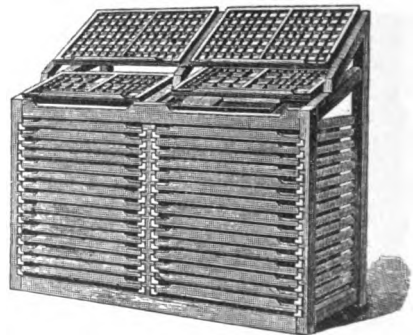

No. 17. Double City Stand. The upper cases project over the lower, bringing the caps nearer the hand. There is a shelf to hold a galley under the lower case, which can be pushed back to permit matter to be emptied on the galley.

NEW YORK SPACE-SAVING CASE STANDS.



New York Double Stand.

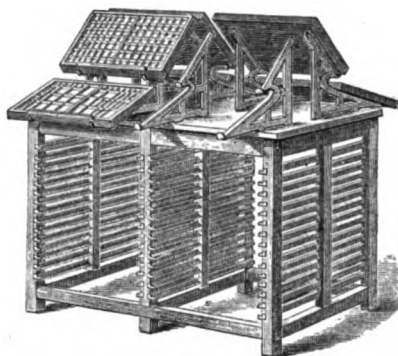

New York Quadruple Stand (see end view below).

These are *space-saving, rent-reducing stands*. Two New York Double Stands, holding sixty cases in racks and four pairs cases on top, occupy eighteen square feet of floor space, as against thirty square feet occupied by two ordinary double stands, holding at most forty-eight cases in racks and four pairs cases on top—a saving of twelve square feet. Two Double City Stands occupy a floor space of twenty-five square feet as against seventeen feet occupied by one Quadruple New York Stand—a saving of eight square feet. This saving is obtained by making the racks correspond to size of cases exactly, bringing forward the cap cases so that they do not overhang at the back of stand (as they do on ordinary stands), and extending the lower cases several inches into the alley.



End view of New York Window and Quadruple Stands.

OTHER POINTS OF SUPERIORITY.

The lower cases project into the alley several inches, affording the compositor ample leg room, and allowing him to get closer to the type. The angle of the lower case is just right for rapid setting. The upper case is raised above the lower, and brought forward closer to the compositor's hand, while not obstructing the figure boxes of the lower case. The cases are held on strong iron brackets, securely screwed to a hard-wood top, which is perfectly smooth, and very useful for storing tied-up matter or for other purposes. The Window Stand is a rearrangement of the Double Stand, so that it occupies a square area, and is very suitable for placing opposite a window.

New York Single Stand, with racks for 15 cases	\$ 6 50
New York Double Stand, with racks for 30 cases	10 50
New York Quadruple Stand, with racks for 60 cases	18 00
New York Window Stand, with racks for 30 cases	10 50

CASE RACKS.

Made of hard wood, bolted together, and the higher racks are braced at the center with iron rods to prevent spreading.

Full-size Cases.	Height.	
Single, to hold 10 cases	38 inches	\$ 5 50
Single, to hold 16 cases	50 inches	7 00
Single, to hold 20 cases	60 inches	8 00
Single, to hold 24 cases	70 inches	9 00
Single, to hold 30 cases	84 inches	10 00
Double, to hold 40 cases	60 inches	14 00
Double, to hold 60 cases	84 inches	18 00

Made to hold two-third and three-quarter cases at same prices.

WOOD-TYPE CASE RACK.

Single, to hold 20 No. 3 Wood-Type Cases	\$9 00
A No. 3 Wood-Type Case is 23x44 inches over all.	

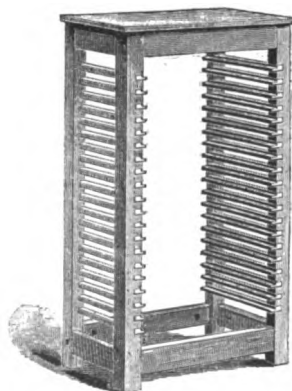

Case Rack for Twenty Full-size Cases.

PERFECTION WROUGHT IRON STANDS.

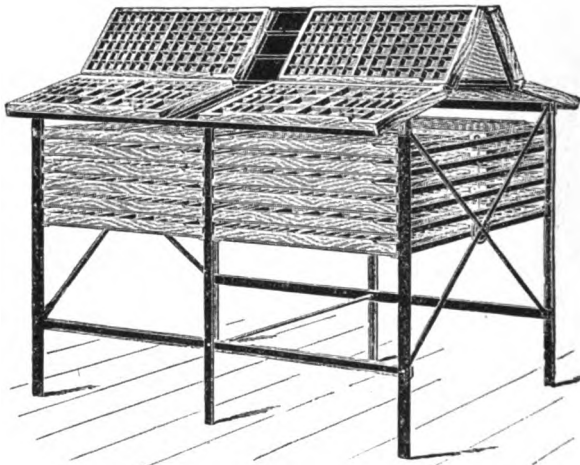

Perfection Quadruple Wrought Iron Case Stand,
with Racks for Twenty-four Cases.

The Quadruple Stand has novel features. The cases on top project eight inches from the rack, giving the compositor plenty of knee room. The galleys between top cases are six inches wide, and divided into convenient spaces.

No stands are so durable and "ship-shape"-looking as those made of iron. These stands are exceptionally well made.

Perfection Quadruple Stand, with racks for 24 cases	\$30 00
Perfection Quadruple Stand, with racks for 48 cases	35 00
Perfection Double News Stand, with racks for 12 cases	16 00
Perfection Double Book Stand, with racks for 24 cases	20 00
Single News Stand, with racks for 8 cases	10 00
Double Job Stand, with racks for 12 full-size and 12 two-third cases	20 00
Double Stand (racks back to back), with racks for 12 cases	16 00

Made for full-size, three-quarter or Rooker cases at the same prices.

REGULAR WROUGHT IRON STANDS.

Made of tubular iron, with strengthened and bolted joints. The best made of this class of stand.

No. 2. Single, with racks for 8 full-size cases	\$10 50
No. 5. Double, with racks for 8 full-size cases	13 50
No. 6. Double, with racks for 8 full-size cases and galley rest	15 00
No. 8. Double, with racks for 8 full-size and 8 two-third cases	17 00
No. 9. Double, with racks for 16 full-size cases and galley rest	18 50

WISCONSIN HARD-WOOD CABINETS

With "New Departure" Cases.

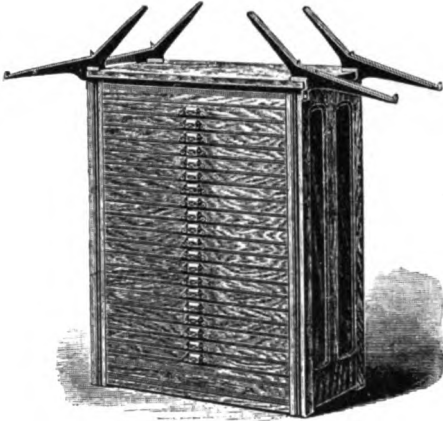

Twenty-Case Wisconsin Cabinet with Flat Top, showing Double Case Bracket, Style A*, attached to top, for holding two pairs of cases.

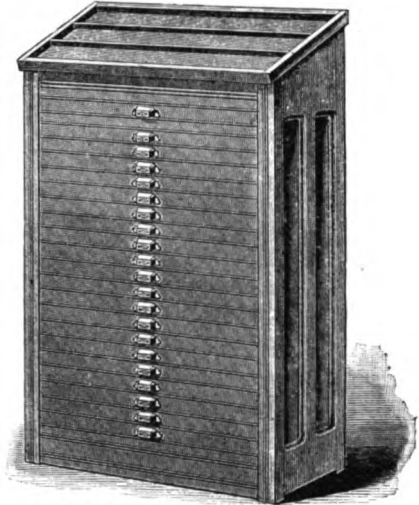

Twenty-Case Wisconsin Cabinet with Galley Top and Copy Drawer.

Although made of hard wood, cherry finish, these cabinets are sold at the same prices as ordinary cheap-looking stained cabinets. Three-quarter and full-size cabinets are furnished with California job cases, described on page 848, which are preferable to Italic cases, as they afford more room for the caps. The bottoms are made flush with the floor, to prevent pi from getting underneath. The sides are double paneled and very tastefully moulded. Double case brackets may be put on top of the flat-top cabinets, making a very convenient stand, the regular height from the floor. *Galley-top Cabinets are kept in stock with twenty cases only, but can be furnished for twelve and sixteen cases to order, though not recommended.*

LIST PRICES.

	Flat Top.	Galley Top.
With 12 Two-third Job Cases	\$15 00
With 16 Two-third Job Cases	18 00
With 20 Two-third Job Cases	21 00	\$24 00
With 12 Three-quarter California Job Cases	18 00
With 16 Three-quarter California Job Cases	22 00
With 20 Three-quarter California Job Cases	26 00	29 00
With 12 Full-size California Job Cases	22 00
With 16 Full-size California Job Cases	26 00
With 20 Full-size California Job Cases	30 00	33 00

See page 861 for Blank Case Cabinets.

*** DOUBLE CASE BRACKETS, STYLE A,**

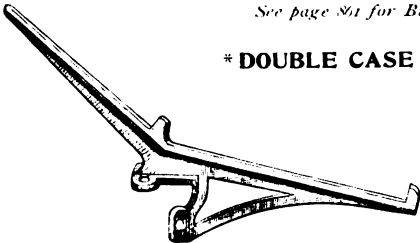

Which fit on top of flat-top cabinets, to hold a pair of cases, per pair \$1 50

For Brackets of all kinds, see page 866.

AMERICAN STEEL-RUN CABINETS

Hold 50 per cent. more type in same floor space occupied by Regular 20-Case Cabinets.

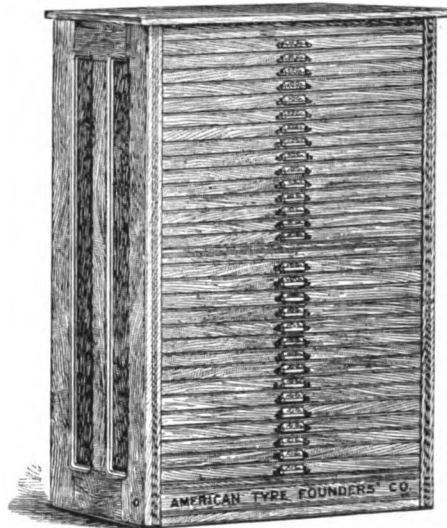

By substituting steel for wood in the runs, the awkward upper projections on the fronts of regular cabinet cases (which in the ordinary are put on to hide the wooden runs) are dispensed with, and ten more cases are got into the same space. Cases are easier to set out of, and *all cases are within easy reach of compositors of average height.*

The cabinets are made of hard wood, polished, braced in center to prevent spreading, and California job cases (giving one-third more room for caps by dispensing with two superfluous rows of boxes) are used instead of Italic cases.

The height of the 30-case cabinets is 53 inches; of the 40-case, 68 inches. Cabinets can be supplied any height, but very high cabinets cannot be recommended owing to the loss of time in getting the top cases out of them.

Attention is directed to the common-sense assortment of cases in these cabinets. In thirty cases there will be required some cases for holding cap and small cap fonts.

The illustration herewith shows the steel run used in American Cabinets. Screws are countersunk.



Shows Steel-Run with Countersunk Screws.

LIST PRICES.

	Flat Top.	Galley Top.
30-case American Steel-Run Cabinet, with 25 two-third job and 5 two-third cap cases	\$35 00	\$38 00
30-case American Steel-Run Cabinet, with 25 three-quarter California job and 5 three-quarter cap cases	40 00	43 00
30-case American Steel-Run Cabinet, with 22 full-size California job, 5 full-size cap, and 3 full-size triple cases	45 00	48 00
40-case American Steel-Run Cabinet, with 30 two-third job and 10 two-third cap cases	48 00	52 00
40-case American Steel-Run Cabinet, with 30 three-quarter California job and 10 three-quarter cap cases	53 00	57 00
40-case American Steel-Run Cabinet, with 30 full-size California job, 6 full-size cap, and 4 full-size triple cases	60 00	64 00

**PORTER'S PATENT EXTENSION FRONT
STEEL-RUN CABINET.**

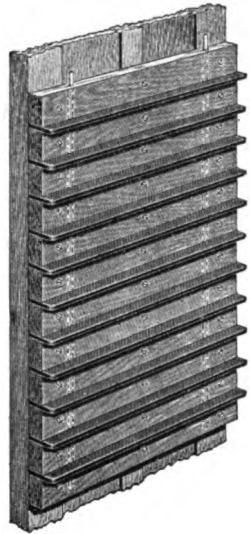
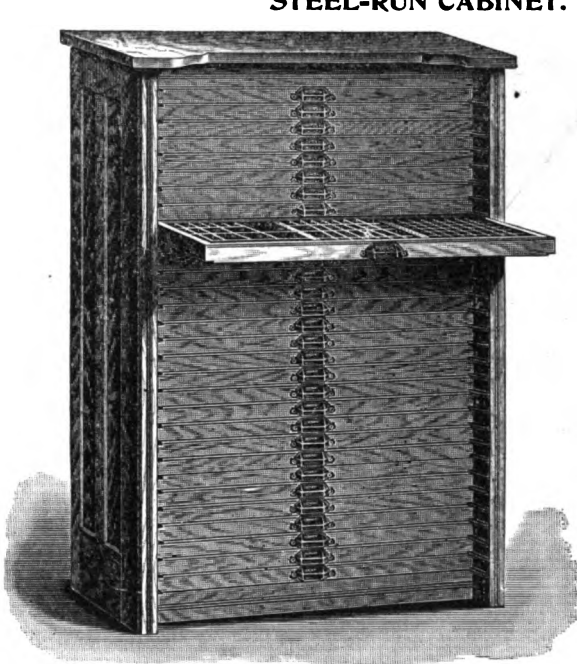

Shows construction of runs in Porter Cabinets. The steel runs are secured between wood, the wood screwed to sides, and two iron rods are passed through as extra strengtheners.

Notice the extension sides, the chief merit of this cabinet. These sides project out far enough to temporarily hold any of the cases the rack for which may be too high or too low for the convenience of the compositor.

The sides of these cabinets are extended four inches beyond the fronts of the cases. These extensions serve the printer in two ways: (1) A case near the top of a cabinet may be taken from its rack and placed in a more convenient position for setting from, and will be held by the extensions without withdrawing another case. This cannot be done on any other cabinet. (2) The extensions permit cases to be drawn out further from the racks than is possible in other cabinets, making it easier to set out of the rear boxes. In addition, these cabinets have all the best points of other cabinets, such as steel runs, "New Departure" cases, hard wood throughout, and are stronger than any other cabinets, as will be seen by examining the sectional illustration above.

The extension sides make it practicable to use higher cabinets, containing more cases in a tier, than can be advised where ordinary cabinets are used.

LIST PRICES.

No. 1½,	with 25 full-size California job cases, one tier, height 45 inches	\$43 00
No. 2½,	with 30 full-size California job cases, one tier, height 53 inches	51 00
No. 3½,	with 40 full-size California job cases, one tier, height 63 inches	68 00
No. 4½,	with 50 full-size California job cases, one tier, height 84 inches	85 00
No. 8,	with 25 full-size blank cases, one tier, height 45 inches	38 00
No. 9,	with 30 full-size blank cases, one tier, height 53 inches	45 00
No. 10,	with 40 full-size blank cases, one tier, height 63 inches	60 00
No. 11,	with 50 full-size blank cases, one tier, height 84 inches	75 00

Porter Cabinets of greater height can be supplied if desired. As all the above cabinets have flat tops, we do not list any double cabinets. A double 25-case (50 cases in all) will cost \$85 00; a double 30-case, \$100 00. Single tier, flat-top cabinets are always preferable to double, because it is easier to find positions for them. They are moved easier, and there is no saving in space by using double flat-top cabinets.

“AMERICAN-POLHEMUS” CABINETS.

All Hard Wood, Cherry Finish.

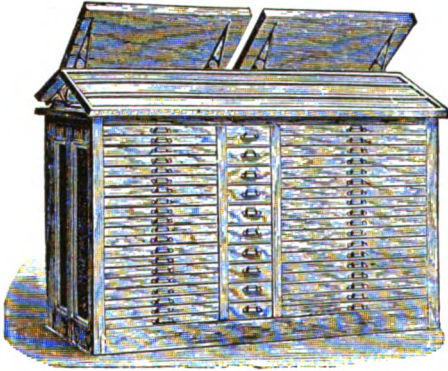

Front view of American-Polhemus Double Cabinet, showing Sort Drawers, Galley Top and Jobbing Cases.

The object of the American-Polhemus Cabinet is to save time and space. Time is lost on the ordinary cabinets by stationing the compositor in front of twenty cases, all frequently in use by other men, who, when setting or distributing from them, keep the man at the cabinet idle. On the American-Polhemus Cabinets the job cases are unobstructed, and the compositor stands at the back, where he cannot be interrupted. If he is setting solid matter he can empty his sticks, without walking a step, on a galley kept under his lower case, as the cases are held by the Patent Tilting Bracket and Galley Rest. Illustrated on page 858.

Every inch of space on the American-Polhemus Cabinets is utilized to advantage. The galley top or bank is a most useful addition. The space between the cases is used as a sort cabinet. The top is flat, and tied-up matter may be kept on it, as the iron case brackets admit of easy access to the space under the cases and galley top. The brackets which hold the cases project into the alley eight inches, giving the compositor plenty of knee-room, while saving floor-space.

Every inch of space on the American-Polhemus Cabinets is utilized to advantage. The galley top or bank

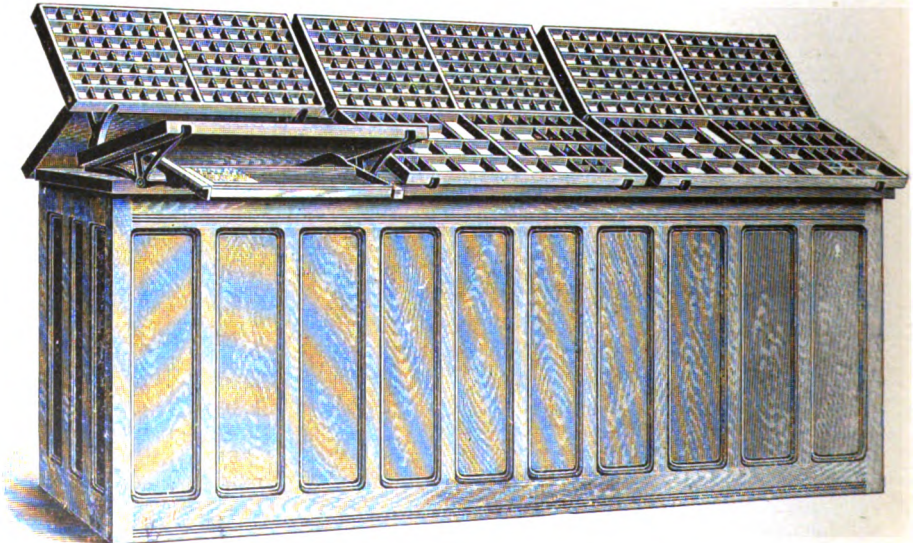

Back of American-Polhemus Triple Cabinet, showing arrangement of Body-letter Cases on the Patent Tilting Brackets.

PRICES OF AMERICAN-POLHEMUS CABINETS.

- No. 2½. Single American-Polhemus Cabinet—Complete with 18 full-size California job cases, 1 pair of news cases, galley top, and 1 pair of patent tilting brackets **\$35 00**
- No. 1½. Double American-Polhemus Cabinet—Complete with 18 full-size and 20 three-quarter California job cases, 2 pairs of news cases, galley top, 10 sort drawers, and 2 pairs of patent tilting brackets **75 00**
- No. 3½. Triple American-Polhemus Cabinet—Complete with 18 full-size and 40 three-quarter California job cases, 3 pairs news cases, galley top, 10 sort drawers, and 3 pairs of patent tilting brackets **110 00**
- No. 4½. Triple Polhemus Cabinets *with steel runs*—Complete with 50 three-quarter and 25 full-size California Job Cases in three tiers (25 in a tier), 3 pairs news cases, galley top, 10 sort drawers, and three pairs of patent tilting brackets . . . **140 00**

STEEL-RUN AMERICAN-POLHEMUS CABINETS.

All Hard Wood, Cherry Finish.

These cabinets are similar to the American-Polhemus Cabinets, illustrated on these pages, except that the use of steel runs instead of wood runs increases their case-holding capacity without changing floor space or height.

- No. 5½. Double American-Polhemus Cabinet—Contains 18 full-size California job, 3 full-size triple, 4 full-size cap, 20 three-quarter California job, 5 three-quarter cap, and 2 pairs of full-size news cases on top, 10 sort drawers, a galley top, and 2 pairs of patent tilting brackets **\$95 00**
- No. 6½. Double American-Polhemus Cabinet—Contains 43 full-size California job, 4 full-size cap, 3 full-size triple, and 2 pairs of full-size news cases on top, a galley top, and 2 pairs of patent tilting brackets (*no sort drawers*) **95 00**
- No. 7½. Single American-Polhemus Cabinet—Contains 19 full-size California job, 3 each full-size triple and cap cases, 1 pair of full-sized news cases on top, a galley top, and 1 pair of patent tilting brackets **47 00**

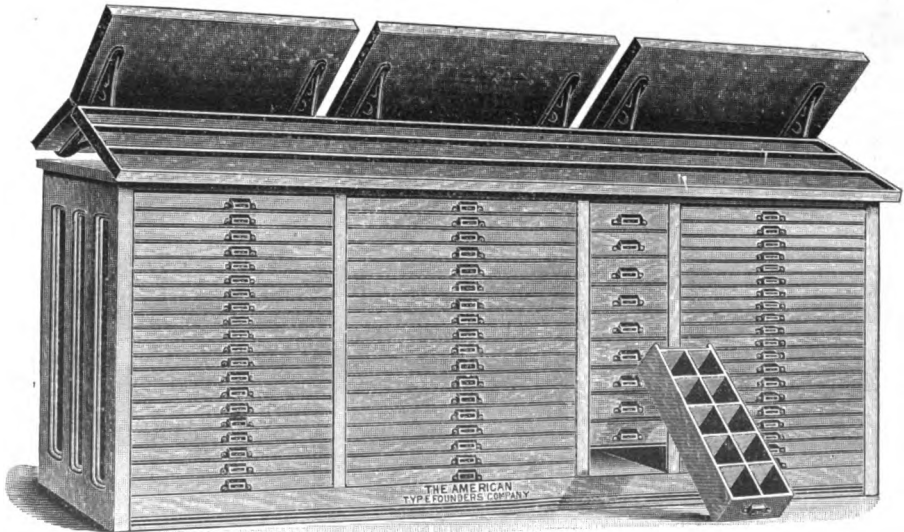

Front of American-Polhemus Triple Cabinet, showing Jobbing Cases, Sort Drawers, and Galley Top or Bank.

WISCONSIN WINDOW CABINET.

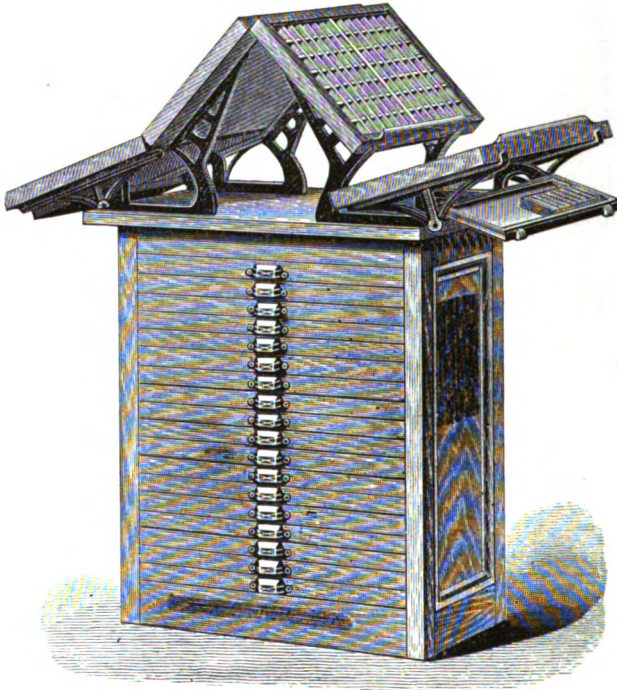

Specially designed for placing in front of a window, as it does not obstruct the light, of which the cases on top get the full benefit. Two men may work undisturbed at the sides, while the job cases in front are convenient for other men. The top is flat, and useful for holding tied-up type.

These cabinets have the patent tilting bracket and galley rest, which enables a compositor to empty his stick without leaving the cabinet by simply tilting his lower case, as shown in the cut, thus exposing the galley.

Wisconsin Window Cabinet, with 2 pairs of Patent Tilting Brackets and 18 full-sized California job cases, 2 pairs of news cases on top, hard wood, cherry finish \$36 00

PATENT TILTING CASE BRACKET.

Used on Wisconsin Window and American-Polhemus Cabinets.

B B (outline) shows bracket holding case in position for setting. Shaded cut shows bracket tilted up, allowing compositor to empty on galley below lower case, which is more clearly shown in cut of Wisconsin Window Cabinet printed above. These brackets are also supplied with all American-Polhemus Cabinets.

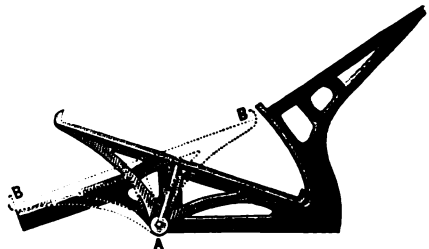

COMBINATION CABINET No. 1.



Made of hard wood, cherry finish. Contains 18 full-size California job, 18 two-third job, 2 pairs full-size news cases on top, 2 copy drawers, and 10 sort drawers with partitions \$75 00

EAGLE CABINET.

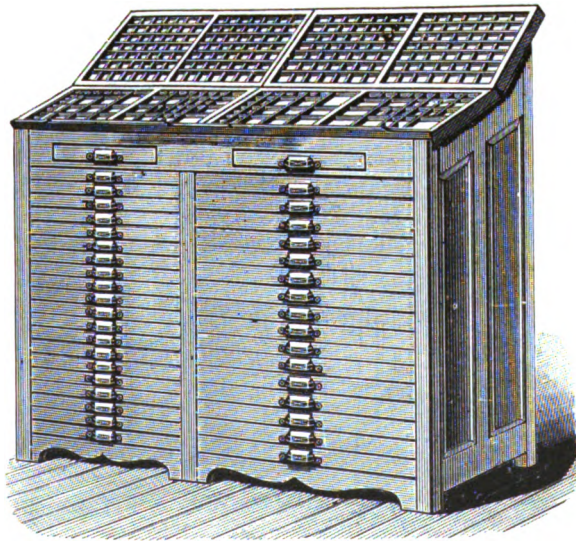

Made of hard wood, cherry finish. Contains 40 cases in all, including 12 full-size California job, 2 each full-size triple and cap cases, 20 three-quarter California job cases, 2 pairs full-size news cases on top, and 2 copy drawers \$70 00

INDEXED ELECTRO-TYPE CABINET.

Antique Oak Finish.

Fitted with the special cases illustrated below, each furnished with strong adjustable slotted partitions, each case numbered in front, and each section in the case designated by initial label, for which a secure holder is provided. The cuts in each lengthwise section are separated and held in place by shallow crosswise slats. An Index Book with each cabinet in which the cuts are indexed as follows:

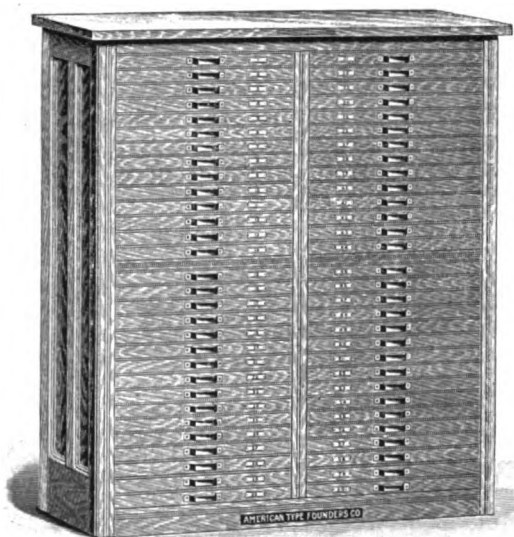

Nos. 6, 12, and 18 Cabinets, containing 60 Cases.

ORIGINAL CUT			NAME OF CUT	ELECTROTYPES		
DRAPER	SECTION	DIVISION		DRAPER	SECTION	DIVISIONS
12	D	3	Bicycle	31	B	1 2 3
12	A	2	Lawn Mower	33	A	4 5 6
12	E	3	Sewing Machine	35	B	1 2 3
12	D	4	Factory Plant	30	C	7 8 9

These cabinets meet in every respect the requirements of not only printers but of all manufacturing concerns that use cuts largely. Printers will do a favor to their customers of this class by calling their attention to these new cabinets. They are substantially and handsomely made of ash, finished in antique oak. The cases slide on steel runs, so that they take up the least possible space. The dimensions, weight and prices are given on next page.

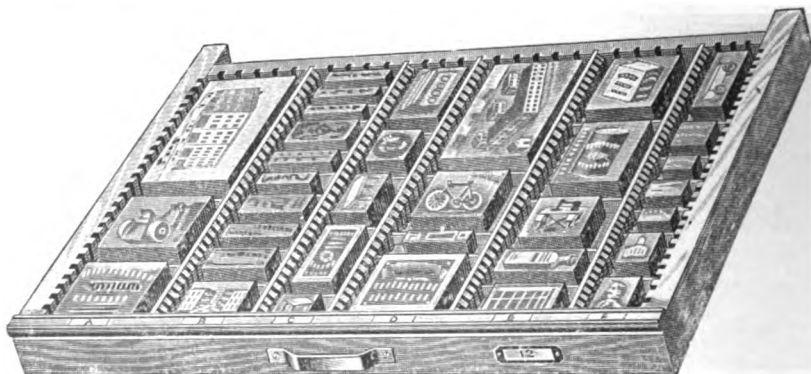

Case furnished in Indexed Electrotpe Cabinets.

Note that every cut is in a distinct compartment, and that as many sections and divisions of sections can be made as are desired. The plan of the index printed above refers to the case shown here.

PRICE LIST OF INDEXED ELECTROTYPE CABINETS.

View of full-length Slotted Section Slats.



The Division Slats, which are shallow, fit into these Section Slats as shown in cut on preceding page.

No.	Size of Cases Inches.	Height Inches.	Weight Lbs.	Price.
1, with 20 two-third cases	16 x 21 3/4	38	180	\$25 00
2, with 25 two-third cases	16 x 21 3/4	45	225	30 00
3, with 30 two-third cases	16 x 21 3/4	53	275	35 00
4, with 40 two-third cases	16 x 21 3/4	68	350	48 00
5, with 50 two-third cases	16 x 21 3/4	84	425	60 00
6, with 60 two-third cases	16 x 21 3/4	99	475	72 00
7, with 20 three-quarter cases	16 x 26 1/4	38	200	30 00
8, with 25 three-quarter cases	16 x 26 1/4	45	250	35 00
9, with 30 three-quarter cases	16 x 26 1/4	53	300	40 00
10, with 40 three-quarter cases	16 x 26 1/4	68	400	53 00
11, with 50 three-quarter cases	16 x 26 1/4	84	475	65 00
12, with 60 three-quarter cases	16 x 26 1/4	99	550	78 00
13, with 20 full-size cases	16 x 32 1/4	38	250	35 00
14, with 25 full-size cases	16 x 32 1/4	45	300	40 00
15, with 30 full-size cases	16 x 32 1/4	53	350	45 00
16, with 40 full-size cases	16 x 32 1/4	68	475	60 00
17, with 50 full-size cases	16 x 32 1/4	84	575	75 00
18, with 60 full-size cases	16 x 32 1/4	99	650	90 00

The fifty-case and sixty-case cabinets are furnished in one or two tiers, as desired.

SPECIAL NOTICE.—The above prices include the cabinets fitted with a full equipment of division slats, including five of the slotted section divisions for each drawer in the two-thirds size cases, and six for each drawer in the three-quarter and full-size cases; also with a large assortment of cross divisions, in various lengths. Each drawer is fitted with a metal number plate, as shown in the illustrations on preceding page. One index book is furnished with each cabinet.

ELECTRO AND CUT CABINETS.

Antique Oak Finish.



Flat-Top Sixteen-Case Electro Cabinet.

These cabinets are filled with blank cases, and are made of polished ash, antique oak finish, with bronze case-pulls. The cases have extension backs. In addition to the ordinary use of the printer, these cabinets can be recommended to advertisers for keeping their wood cuts, etc., for keeping samples of hardware, confectionery, fancy stationery, for seeds, and for many other purposes.

All sizes can be supplied with galley tops at an advance of \$3.00 on flat-top prices, but galley tops are not recommended except on 20-case cabinets.

	Size of Cases. Inches.	Height of Cabinet. inches	With Flat Top.	Galley Top.
12 Two-third Blank Cases	16 x 21 3/4	34 inches	\$12 00	
16 Two-third Blank Cases	16 x 21 3/4	42 inches	14 00	
20 Two-third Blank Cases	16 x 21 3/4	50 inches	16 00	\$19 00
12 Three-quarter Blank Cases	16 x 26 1/4	34 inches	15 00	
16 Three-quarter Blank Cases	16 x 26 1/4	42 inches	18 00	
20 Three-quarter Blank Cases	16 x 26 1/4	50 inches	21 00	24 00
12 Full-size Blank Cases	16 x 32 1/4	34 inches	19 00	
16 Full-size Blank Cases	16 x 32 1/4	42 inches	22 00	
20 Full-size Blank Cases	16 x 32 1/4	50 inches	25 00	28 00

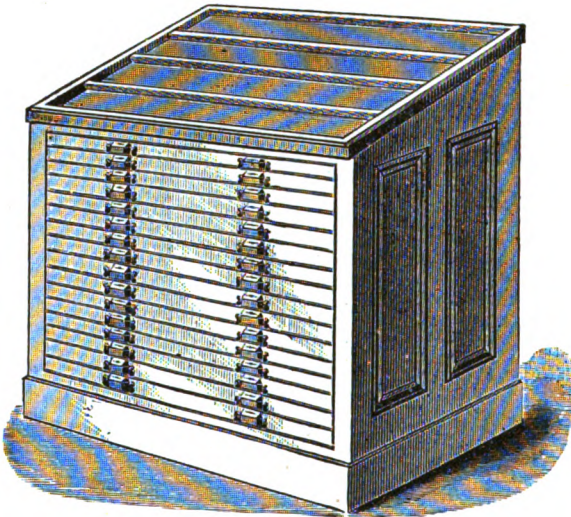

No. 5 Wood-Type Cabinet, with Galley Top. Occupies nine square feet floor space, and affords one hundred and twelve square feet for storage of type.

WOOD-TYPE CABINETS.

Very substantially constructed of hard wood, cherry finish. The cases are slotted on the sides, and have movable strips which may be adjusted to Picas. The cases in the Mammoth Cabinet (23 x 44 inches) have a center bar, and cases in the Regular Cabinet (23 x 32 inches) have no center bar.

These cabinets afford the most economical method of keeping wood type. The top of cabinet is available for use in laying out lines. They save the time lost in climbing to shelves, and the wood type is kept clean and is less liable to warp.

	Flat Top.	Galley Top.
No. 1. 12 cases, 23 x 32 inches	\$20 00	\$23 00
No. 2. 16 cases, 23 x 32 inches	25 00	28 00
No. 3. 20 cases, 23 x 32 inches	30 00	33 00
No. 4. 12 cases, 23 x 44 inches	25 00	28 00
No. 5. 16 cases, 23 x 44 inches	33 00	36 00
No. 6. 20 cases, 23 x 44 inches	40 00	45 00

WOOD-TYPE CASE RACK.

To hold twenty No. 3 Wood-Type Cases (made to order) \$9 00

For prices of Wood-Type Cases, see page 845. No. 3 Wood-Type Cases are 23 x 44 inches over all, and the price is \$1 30 each.

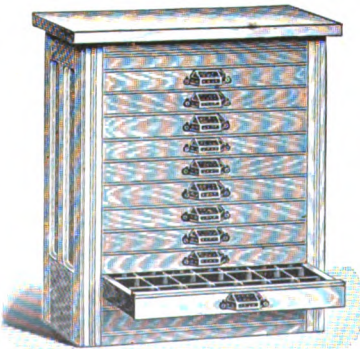

BOOKBINDERS' CABINETS.

Made of hard wood, cherry finish, with bronzed pulls on each case. The cases are made in exactly the same style as printers' cases. These cabinets occupy a space of 20 x 20 inches, and may be put on or under a bench. "A place for everything and everything in its place" is a rule bookbinders should live up to, and these cabinets enable them to do so.

- Cabinets with 6 cases . . \$ 8 00
- Cabinets with 10 cases . 12 00
- Cabinets with 15 cases . 16 50

BOOKBINDERS' CASE.

Half Cap Case, 16 x 16 1/4 inches, without bronze pull, each \$0 60

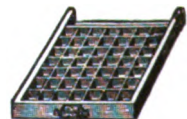

Case used in Bookbinders' Cabinet.

ROWEN BORDER AND SCRIPT TYPE CABINETS.

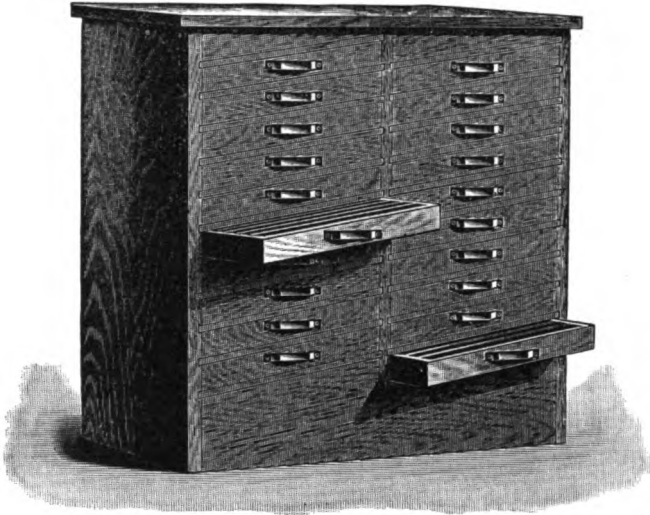

Rowen Border Cabinet with Twenty Cases.

These cabinets supply the long-felt need of a proper receptacle for borders, keeping them in compact shape and preserving the face.

The cases in these cabinets are 10×12 inches inside, and are tilted sufficiently to keep the type on its feet. The borders or type are held between movable division strips, which are 18 Points wide, while the slots into which these strips fit are set 6 Points apart, so that they can be adjusted to hold 6, 12, 18, 24, 30, 36, 42, 48, 54, 60, or 72 Point bodies, while such irregular and seldom-used bodies as 8 and 9 Point may be carried in the 12-Point drawers, or special strips may be procured for them.

For script type a quantity of metal pinch springs is furnished with each cabinet, for inserting between the different letters in a font, so that if all the letters "d" are removed, the pinch spring holds the letters "e" on their feet. The advantages of keeping delicate scripts in cases where the faces of the letters are not subject to friction and scratching will be apparent to all.



Rowen Border and Script Type Cabinet with Four Drawers.

LIST PRICES.

No. 1, 4 drawers, one tier, height 12 inches	\$ 8 00
No. 2, 6 drawers, one tier, height 16 inches	10 50
No. 3, 10 drawers, one tier, height 25 inches	16 00
No. 4, 16 drawers, two tiers, height 21 inches	25 00
No. 5, 20 drawers, two tiers, height 25 inches	30 00
No. 6, 30 drawers, two tiers, height 35 inches	45 00
No. 7, 40 drawers, two tiers, height 44 inches	60 00

Each case will hold 30 feet of 6-Point, or 24 feet of 12-Point, or 20 feet of 18-Point, or 17 feet of 24-Point, or 15 feet of 30-Point, or 13 feet of 36-Point borders.

HANDY SORT CABINETS.

These cabinets are fitted with serviceable sort drawers which should supplant the various cigar-box-tin-can arrangements which disgrace so many offices. The drawers are 8 x 20 inches over all, and two inches deep. The cabinets are very strong, made of hard wood, and remarkably low-priced. The drawers, which are also for sale separately, have movable partitions, and may be adjusted to the special requirements of any printing office. All drawers have strong bronze drawer-pulls, whether sold in cabinets or separately.

A picture of the drawer is shown below. Drawers are sold separately if required.

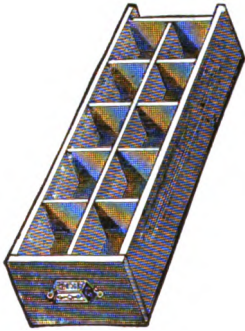

Handy Sort Cabinet, with Thirty Drawers.

Cabinet with 10 Handy Sort Drawers	\$12 00
Cabinet with 20 Handy Sort Drawers	23 00
Cabinet with 30 Handy Sort Drawers	35 00
Cabinet with 40 Handy Sort Drawers	47 00
Cabinet with 50 Handy Sort Drawers	59 00
HANDY SORT DRAWERS, each	0 90

Sort Cabinets made to order to fit any space, or to any dimensions, at proportionate prices.

PAPER AND CARD STOCK CABINETS.

Made very strongly of hard wood, cherry finish. High-priced papers and cardboard should be kept in a dust-tight receptacle, to prevent wastage and economize space. The drawers have extension backs, and are strongly constructed.

No. 1, 12 drawers, each drawer holding 22½ x 28-inch cardboard, or smaller.

Price \$37 00

No. 2, 12 drawers, each drawer taking full sheet of 28 x 42 inches.

Price \$48 00

The cabinets are 48 inches high. The drawers are 2½ and 5 inches deep, and have movable partitions.



No. 1 Paper Stock Cabinet. Occupies 26 x 34 inches floor space.

**LINOTYPE
MATRIX CABINET.**

Has roll curtain front, with lock. Made of hard wood, beautifully finished, and very substantial. Each drawer is 14¼ × 15 inches inside, and holds 142 running inches of matrices set edgewise. A locked tool drawer, 4½ inches deep, is placed at the bottom, which also holds the space bars on a brass rod.

- No. 1. 6 matrix and 1 tool drawers, height 29½ ins. \$22 00
- No. 2. 8 matrix and 1 tool drawers, height 34 ins. 28 00
- No. 3. 10 matrix and 1 tool drawers, height 38½ ins. 34 00
- No. 4. 12 matrix and 1 tool drawers, height 43 ins. 40 00

Six metal slugs, same shape and size as a matrix and ¾-inch wide, furnished with each drawer. These hold up the matrices at ends of lines.

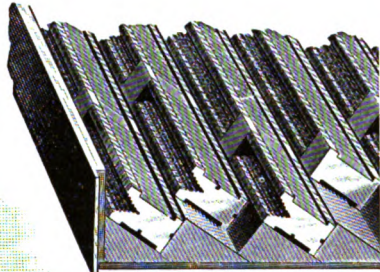

Detailed Section of Matrix Drawer, showing Matrices in place.



Eight-Drawer Linotype Matrix Cabinet.

SPECIMEN CABINETS.

Made of ash, with antique oak finish. These cabinets are handsomely made, and will be an ornament to any office.

The drawers have movable partitions, and are made in two depths—2½ inches and 5 inches. The No. 1 Cabinet is the proper height for placing a letter-copying press on.

The methodical classification and preservation of specimens in a cabinet enables customers to decide on what they want quickly, and in many cases suggests other requirements. Let the public see what you have to sell, and they will become buyers.

- No. 1, 8 drawers, 26 inches wide by 19 inches deep by 42 inches high \$14 00
- No. 2, 12 drawers, 26 inches wide by 19 inches deep by 50 inches high 20 00

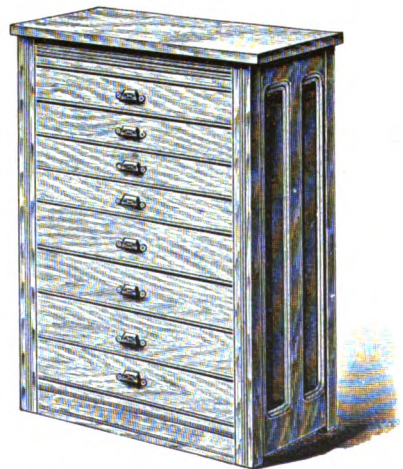

No. 1 Specimen Cabinet, 26 inches wide, 42 inches high, and 19 inches deep.

CHALLENGE LAMP HOLDER.

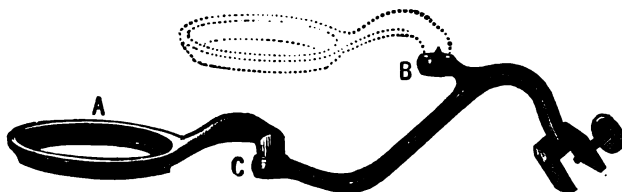

A most convenient and safe attachment for holding a lamp over the compositor's case. It will be readily understood by reference to the cut that the fount holder A can be instantly raised from C to B, as shown by the dotted lines, to adapt the position of the light to suit the compositor. Small thumb screws at

the top of B and C, with suitable recesses in A, retain the light perfectly stationary in any position.
Each \$0 75

BRACKETS.

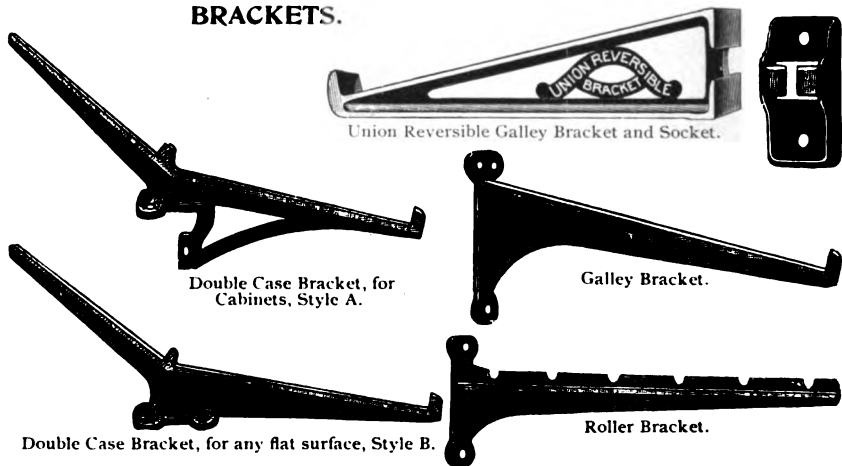

- Double Case Brackets, style A, fit on end of Flat Top Cabinet, per pair \$1 50
- Double Case Brackets, style B, fit on any flat surface, per pair 1 25
- Single Case Brackets, per pair 0 75
- Galley Brackets, per pair 0 40
- Roller Brackets, to hold six platen press rollers, per pair 0 50
- Union Reversible Galley Brackets, with Sockets, per pair 0 60
- Union Reversible Galley Brackets, with Sockets, per dozen pairs 6 00

TYPE-HIGH GAUGE.

Much time may be saved in the press room if the maker-up will test all electrotypes, and have those that are high or low brought to the proper height by an electrotyper, or do it himself, before the form goes to press. The wise employer should insist on the use of this Gauge.

Price, each. \$2 50

See Type-High Machine on opposite page, and Backing for Electrotypes on page 973.



PRINTERS' SAW TABLE,

With Shoot-Board Attached.

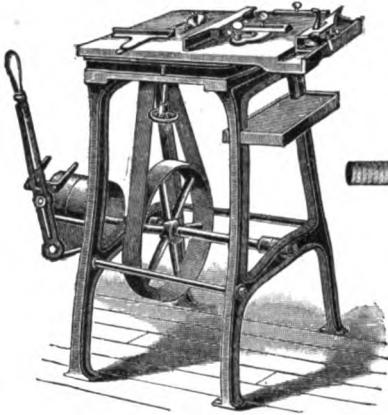

A very necessary machine in large printing offices. It will saw wood, metal or brass, and will trim wood and metal accurately from the merest shave upward. It affords the quickest and most accurate method of cutting slugs, furniture, thick brass rule and

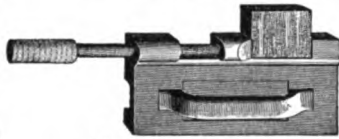

Attachment for Cutting Linotype Slugs.

plates, and as it is fitted in the most complete manner with gauges, all trimming and cutting is done with perfect trueness and squareness. An attachment for sawing linotype slugs is furnished for \$15.00 extra.

This is a thoroughly well-built machine, equal to similar machines used by electrotypers, made of iron and steel, with accurate adjustable gauges. The saw is raised or

lowered by means of a clamp-screw set under the table. The countershaft is attached to the saw, and should not run less than four hundred revolutions per minute. The driving pulley is 7 inches in diameter, for 2½-inch belt. Size of table is 18×24 inches, height 40 inches, and floor space occupied 24×32 inches.

Saw table with shoot-board	\$85 00
Saw table without shoot-board	70 00
Attachment for sawing linotype slugs, extra	15 00

CHALLENGE TYPE-HIGH MACHINE.

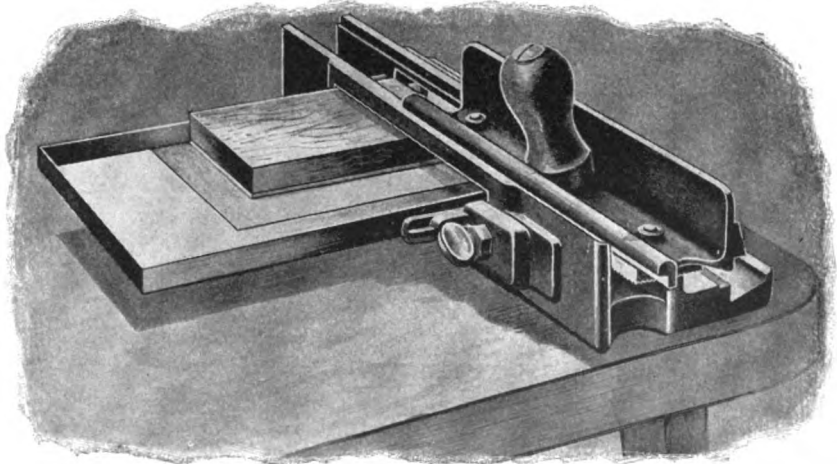

For reducing cuts to type-high, and making them true and even when warped, and for squaring cuts. Full directions with each machine. Descriptive circular on application.

Price	\$12 00
-----------------	---------

For Type-High Gauge, see opposite page.

GALLEY PROOF PRESSES.

AMERICAN PROOF PRESS.

Built in the most substantial manner, thoroughly braced, with accurate bed and cylinder. The cylinder is much heavier than on the average proof press, and consequently gives a much better impression. The best proof press made.

With Iron Stand.

- No. 1, 10 x 31 inches inside \$30 00
- No. 2, 16 x 31 inches inside 42 00

Without Stand.

- No. 1A, 10 x 31 inches inside \$22 50
- No. 2A, 16 x 31 inches inside 30 00

Each proof press is furnished with blanket, brayer frame and stock.

CHALLENGE PROOF PRESS.

Lighter frame and lighter cylinder than the American Proof Press. The best low-priced proof press in the market, and equal to many listed at higher prices.



American Proof Press.

- 10 x 31 inches inside \$27 00
- Each proof press is furnished with blanket, brayer frame and stock.

RELIANCE JOB GALLEY PRESS.

Designed for taking proofs of job work.

- No. A, without table, takes 14 x 20 job galley \$22 50
- No. B, without table, takes 15 x 22 job galley \$25 00

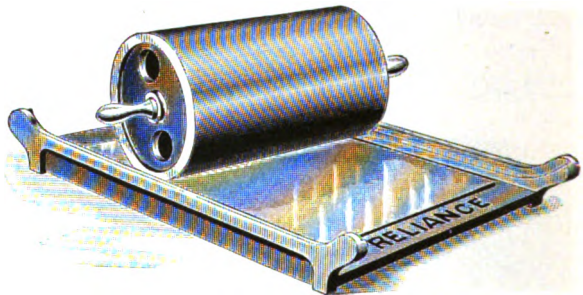

This is the cheapest proof press made. It has no bed, but consists of a roller and braced side frame.

ECONOMIC PROOF PRESS.

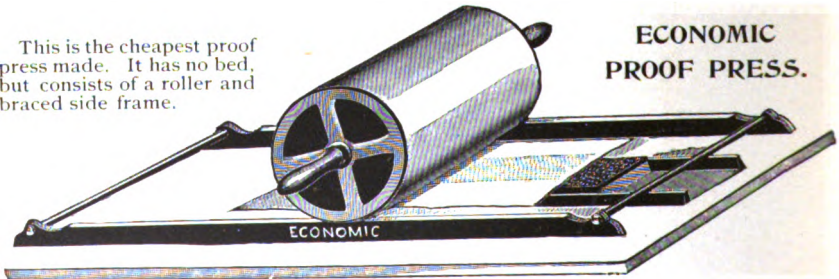

- A mould is provided for casting weights which can be placed inside the cylinder to increase pressure according to character of the work.
- 10 x 34 inches inside, complete with blanket and weight mould \$13 50

**WEBB SUCCESS
SELF-INKING PROOF PRESS.**

• Prints from One or Two Rolls of Paper.



Designed for use in newspaper offices. Used by all the leading New York and Boston daily papers. It operates in the same manner as the Herald-Success Press, described below, with the addition of working from webs of paper.

- With 10-inch bed, for one web of paper, for proving single, double or triple-column galleys \$300 00
- With 12-inch bed, designed for taking two webs and taking two single-column galley proofs at once, or double, triple or quadruple column proofs by using wider single webs 400 00

**HERALD-SUCCESS
SELF-INKING
PROOF PRESS.**

In use in the government printing offices of United States and Canada.

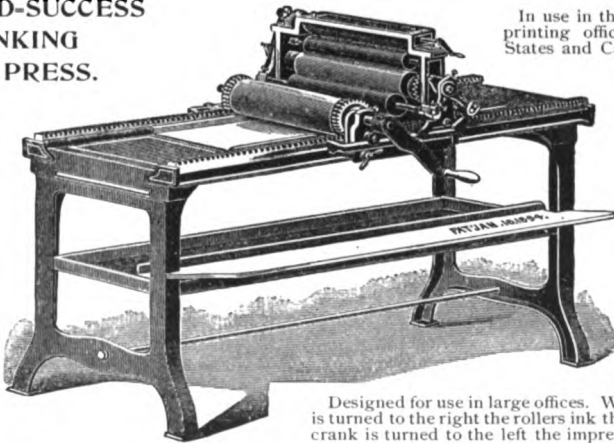

Designed for use in large offices. When the crank is turned to the right the rollers ink the forms, when crank is turned to the left the impression is taken. All movements are automatic. Impression cylinder

is covered with seamless vulcanized rubber, taking clean and sharp impressions.

- With 18-inch bed, capable of proving four single-column galleys at one impression, or large magazine pages \$300 00
- With 24-inch bed, adapted for full-page newspaper proofs 400 00

STANDING GALLEYS.

Made to Order.

Buyers may have these made to any dimensions they desire, at prices proportionate to those quoted below for the sizes and styles commonly used.

The space underneath may be utilized in various ways. In place of the case racks, as shown in the cuts, galley shelves and racks or letter boards can be put in. In ordering Standing Gallies, or in sending for estimates of cost, it is necessary to be *explicit* as to measurements and other requirements.

The regular width of single columns is three inches; of double columns, six inches; but these may be varied. The column strips are made of the same material as ordered for the top.

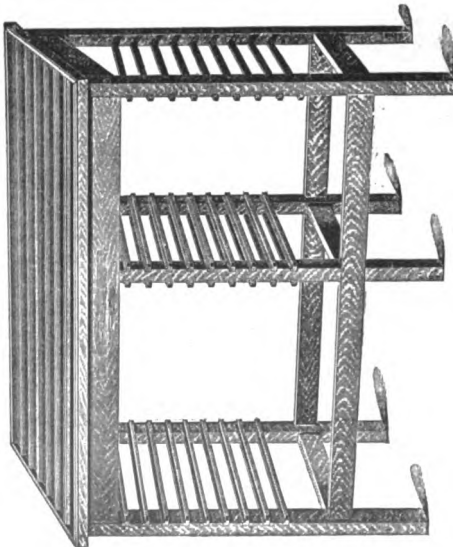

No.	Length Over All.	Material Used on Top.	What the Racks Hold.	Single Columns.						Double Columns.			
				Top 20 ins. wide.	Top 23 1/2 ins. wide.	Top 27 ins. wide.	Top 30 1/2 ins. wide.	Top 34 ins. wide.	Top 37 1/2 ins. wide.	Top 40 1/2 ins. wide.	Top 43 1/2 ins. wide.		
1	5 feet	Hard-wood	8 each full and two-third cases	\$14 75	\$15 25	\$15 75	\$16 25	\$16 75	\$17 25	\$17 75	\$18 25	\$18 75	\$19 25
1A	5 feet	Zinc Lined	cases	23 00	23 00	23 00	24 00	24 00	24 00	25 00	25 00	25 00	26 00
1B	5 feet	Brass Lined	cases	26 00	26 00	26 00	27 00	27 00	27 00	28 00	28 00	28 00	29 00
2	6 feet	Hard-wood	8 each full and two-third cases and 14 galley racks	16 00	16 55	17 10	17 65	18 20	18 75	19 30	19 85	20 40	20 95
2A	6 feet	Zinc Lined	cases and	22 75	24 00	25 25	26 50	28 00	29 25	30 50	31 75	33 00	34 25
2B	6 feet	Brass Lined	14 galley racks	38 80	39 50	40 20	41 50	42 50	43 50	44 50	45 50	46 50	47 50
3	7 feet	Hard-wood	16 full-size cases	20 75	19 45	20 10	20 75	21 40	22 05	22 70	23 35	24 00	24 65
3A	7 feet	Zinc Lined	cases	28 75	29 50	29 50	31 00	32 75	34 50	36 25	38 00	39 75	41 50
3B	7 feet	Brass Lined	cases	35 50	36 50	37 50	38 75	39 75	40 75	41 75	42 75	43 75	44 75
4	8 feet	Hard-wood	16 full-size cases and 14 galley racks	23 50	24 25	25 00	25 75	26 50	27 25	28 00	28 75	29 50	30 25
4A	8 feet	Zinc Lined	cases	31 75	32 50	33 50	34 50	35 50	36 50	37 50	38 50	39 50	40 50
4B	8 feet	Brass Lined	cases	42 00	42 50	43 00	43 50	44 00	44 50	45 00	45 50	46 00	46 50
5	10 feet	Hard-wood	24 full-size cases	25 25	26 25	27 25	28 25	29 25	30 25	31 25	32 25	33 25	34 25
5A	10 feet	Zinc Lined	cases	31 75	32 50	33 50	34 50	35 50	36 50	37 50	38 50	39 50	40 50
5B	10 feet	Brass Lined	cases	38 75	39 75	40 75	41 75	42 75	43 75	44 75	45 75	46 75	47 75
6	12 feet	Hard-wood	32 full-size cases	29 50	30 65	31 80	32 95	34 10	35 25	36 40	37 55	38 70	39 85
6A	12 feet	Zinc Lined	cases	40 75	41 50	42 25	43 00	43 75	44 50	45 25	46 00	46 75	47 50
6B	12 feet	Brass Lined	cases	57 75	58 50	59 25	60 00	60 75	61 50	62 25	63 00	63 75	64 50

STANDING GALLEY WITH LETTER BOARDS.

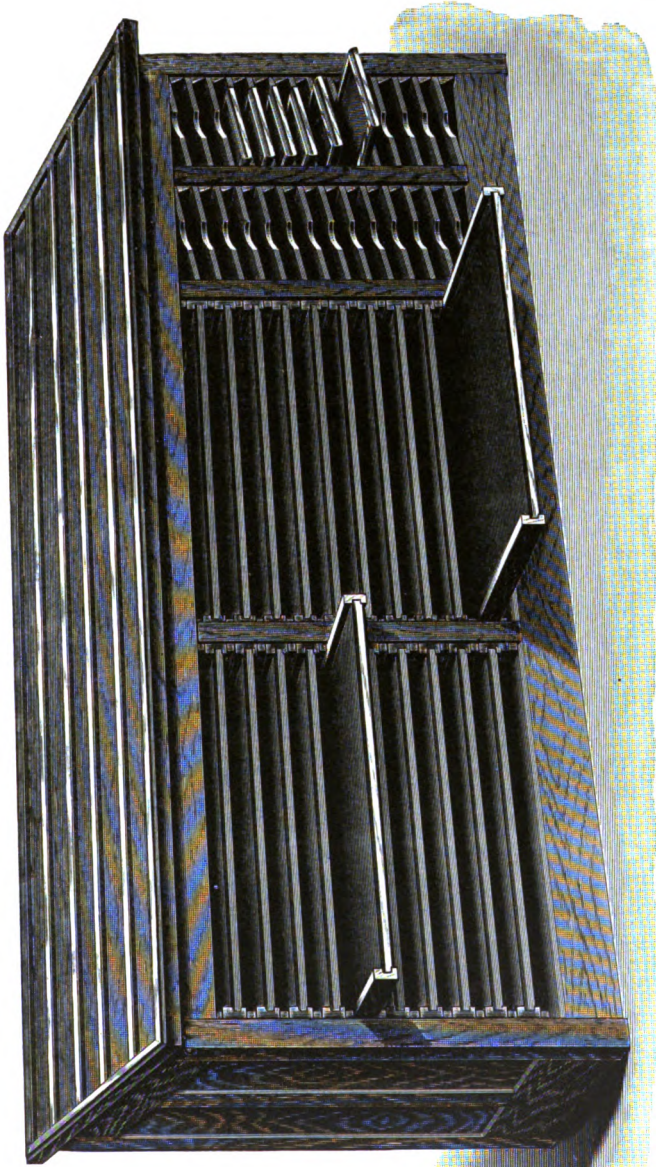

Contains 20 hard-wood letter boards, size of each $24 \times 30\frac{1}{2}$ inches inside, and racks for 36 triple-column galleys; or, if galley racks are not needed, 10 letter boards, each 24×21 inches inside, will be furnished instead at the same price. The brass-top style is covered with a single sheet of finest, hard-rolled brass, and all division strips are lined with brass. Length, 8 feet; depth, 27 inches. Height in front, 3 feet; at back, 3 feet 10 inches.

No. 10, unlined, wood top \$60 00 | No. 11, zinc-lined top \$80 00 | No. 12, brass-lined top \$90 00

WROUGHT IRON HORIZONTAL STANDING GALLEY.

With All-Brass Top.

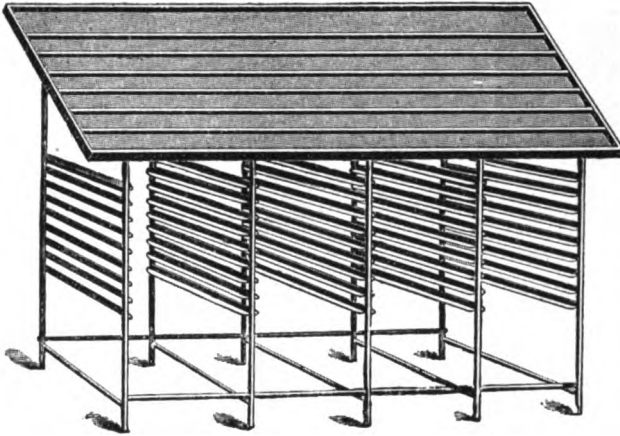

The Wrought Iron Standing Galleys, with columns running horizontally (see cut), have iron racks and all-brass tops. The brass strips screwed on top are L-shaped, making the partitions only a little wider than column width, but leaving enough room for the fingers to lift the type, thus reducing the width of the top, making it more convenient to reach the upper rows. The columns are made to any desired length and width.

The cut on this page is an illustration of the No. 6 size, which is 12 feet long, with iron racks for 32 full-size cases.

No.	Length of Rack.	What the Racks Hold.	5 Single Columns.	6 Single Columns.	7 Single Columns.	8 Single Columns.	9 Single Columns.	10 Single Columns.
1	5 feet	8 two-third and 8 full-size cases	\$54 00	\$58 00	\$62 00	\$66 00	\$70 00	\$74 00
2	6 feet	8 two-third and 8 full-size cases and 16 galley racks	70 00	75 00	80 00	85 00	90 00	95 00
3	7 feet	16 full-size cases	65 00	71 00	77 00	83 00	89 00	95 00
4	8 feet	16 full-size cases and 16 galley racks	80 00	86 00	92 00	98 00	104 00	110 00
5	10 feet	24 full-size cases	85 00	92 00	99 00	106 00	113 00	120 00
6	12 feet	32 full-size cases	95 00	104 00	113 00	122 00	131 00	140 00

WROUGHT IRON LONGITUDINAL STANDING GALLEY.

With All-Brass Top.

Made entirely of brass and wrought iron. The top is covered with sheet brass, and screwed on the hard-wood top from underneath.

Standing Galleys with columns running longitudinally are designed for dead matter, and are almost indispensable. Uniform distribution is guaranteed, as the compositor is compelled to take the type from the top, and gets it into the cases regularly; consequently the type gets an even wear. The front is provided with a channel or gutter for the water used in wetting the type to run off into a receptacle. Any size made to order.

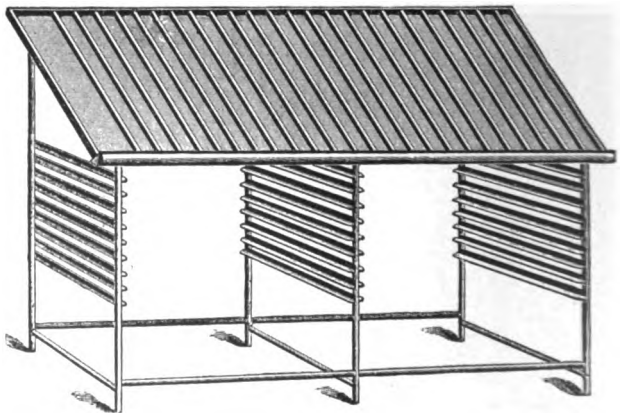

Wrought Iron Standing Galley, with All-Brass Top. This illustrates one 7 feet long and 26 inches wide.

Price, per single column, 26 inches deep, in banks not less than 5 feet long \$3 50

THORNE TYPE-SETTING AND DISTRIBUTING MACHINE.

Type-setting machines, long regarded as an experiment, are now as much of a necessity in the average printing office as cylinder presses, and publishers or printers having any considerable amount of plain book or news composition cannot afford in these days of competition and hurry to rely upon slow, laborious and expensive hand composition, when this simple, reliable, and moderate-priced machine is available, which will produce the same work in a perfect manner in half the time and at less than half the expense of hand work.

The Thorne Type-Setting Machine, using perfect type, produces results typographically equal, if not superior, to the work of the hand compositor; so that not only are these machines now in successful use on news and periodical work, but they are likewise constantly employed in the production of books requiring composition of the most exacting character.

The processes of distribution and composition are combined in a compact and simple machine of marvelous accuracy of construction, occupying but small floor space, and requiring little more power for its operation than a sewing machine.

The different processes of the work are under the instant and ready control of the operators; the distributor may be operated or stopped without interfering with the work of composition, and the setting of

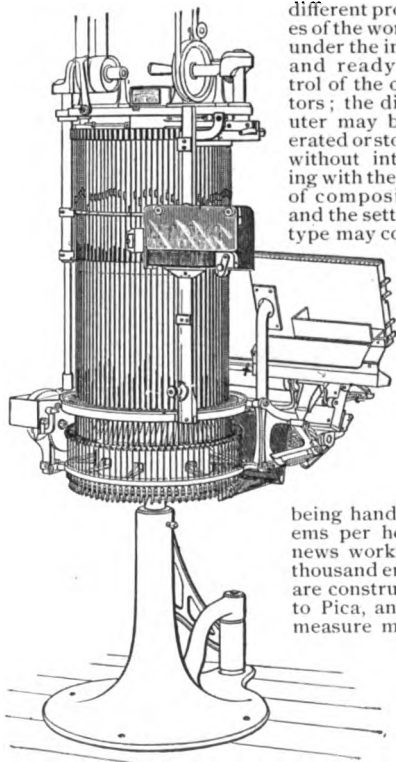

Back view.

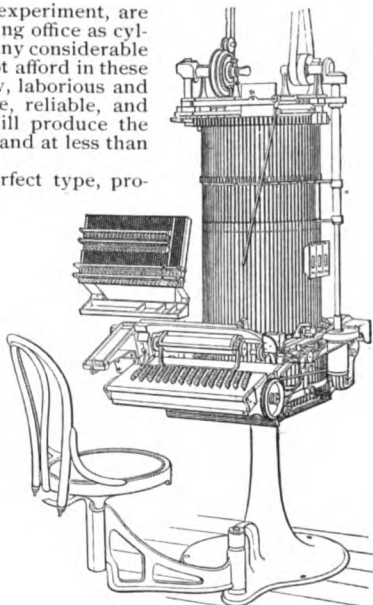

Front view.

type may continue so long as there is type for distribution.

There being no time lost in distribution, composition may be carried on continuously should occasion require it, and it is a common practice to run machines with two sets of operators night and day.

Proficiency in operating the machine is readily acquired after short practice by printers, and no machinist is required in attendance, for all working parts are made interchangeable. When a part becomes worn or damaged it can be replaced by any one of average mechanical ability. The capacity of the machine is limited only by the proficiency of the operator and the character of the work being handled. On book work from five to six thousand ems per hour are readily distributed and set, while on news work and work of similar nature from six to nine thousand ems are produced by expert operators. Machines are constructed to handle any one size of type from Agate to Pica, and for book work are so constructed that the measure may be changed in a minute's time. They are adaptable for use in any language, and machines are now employed by English, French, Finnish, Hebrew and German printers to set the type of newspapers, books and periodicals published in these languages. In the classes of work for which it is designed the machine will earn its cost within a few months.

Prices on application.

FOR THE PRESS ROOM.

FELT BLANKETS.

Width.	Thick. Per Yard.	Thin. Per Yard.	Width.	Thick. Per Yard.
36 inches	\$5 40	\$2 75	56 inches	\$8 50
40 inches	6 00	3 00	58 inches	8 75
44 inches	6 60	3 25	60 inches	9 00
48 inches	7 25	. . .	62 inches	9 50
54 inches	8 10	. . .	65 inches	9 75

FELT BLANKETS.

Size Bed.	Size Blanket.	Thick. Each.	Thin. Each.
17×21	19×20	\$2 75	\$1 75
20×25	23×24	3 25	2 00
21×27	25×25	3 50	2 25
24×30	28×28	4 00	2 75
25×35	29×33	5 50	3 75
29×42	34×40	6 25	5 00
32×46	38×44	8 75	6 50
33×50	38×47	9 75	7 50
36×52	42×49	11 25	9 25
40×54	46×53	12 25	10 00

RUBBER BLANKETS.

Size Bed.	Size Blanket.	Regular Thickness.
17×21	19×20	Each, \$3 00
20×25	23×24	Each, 4 25
21×27	25×25	Each, 4 75
24×30	28×28	Each, 5 75
25×35	29×33	Each, 6 50
29×42	34×40	Each, 8 75
32×46	38×44	Each, 10 50
33×50	38×47	Each, 11 75
36×52	42×49	Each, 13 25
40×54	46×53	Each, 17 00

FELT BLANKETS FOR HAND PRESSES.

For 6-Column Newspaper	\$3 00	For 8-Column Newspaper	\$5 00
For 7-Column Newspaper	3 75	For 9-Column Newspaper	6 50

ROLLER CLOTH.

In rolls 12 yds. long by 2½ in. wide, per roll \$5 00

RUBBER BLANKETS.

	2-Ply 1-16-Inch Thick.	3-Ply 1-12-Inch Thick.	5-Ply ¾-Inch Thick.	Tympan Rubber.
26 inches wide, per yard	\$5 00	\$6 25	\$7 25	. . .
32 inches wide, per yard	5 75	7 00	8 75	. . .
34 inches wide, per yard	6 25	7 50	9 75	. . .
36 inches wide, per yard	6 50	7 75	10 25	\$1 25
38 inches wide, per yard	7 25	8 50	11 25	. . .
40 inches wide, per yard	7 50	8 75	11 75	. . .
44 inches wide, per yard	8 50	10 00	13 50	. . .
48 inches wide, per yard	10 50	12 00	16 00	. . .

TAPE.

¾-inch, per roll	\$0 75	1-inch, per roll	\$1 50
½-inch, per roll	0 75	1¼-inches, per roll	1 60
⅜-inch, per roll	1 00	1½-inches, per roll	1 75
¼-inch, per roll	1 25	1¾-inches, per roll	2 00
⅓-inch, per roll	1 40	A roll of tape contains thirty-six yards.	

TAPE FASTENER.

Fastens tape with eyelets, which are neatly clinched by the fastener.

Price, with box of eyelets \$1 25



TYMPAN PRESSBOARDS.

21×29 inches, each	\$0 50	35×52 inches, each	\$0 25
26×35 inches, each	0 75	40×56 inches, each	1 50
29×42 inches, each	1 00		

METALLIC TAPE COUPLERS.

This is a device for connecting ends of tape on presses and folding machines, so that there will be no wear at the joined parts, as is usual on sewed ends, which wear and cause the tape to run crooked and throw paper out of register. The Metallic Tape Coupler outlasts other methods of securing the ends of tape, and keeps the tape running true. It can be put on in a few seconds by means of Parallel Pliers made for that purpose.

PRICE PER BOX OF FIFTY.

No. 1, for 1/8-inch tape	\$1 25	No. 4, for 3/8-inch tape	\$1 75
No. 2, for 3/8-inch tape	1 50	No. 5, for 1-inch tape	1 75
No. 3, for 1/2-inch tape	1 50	No. 6, for 1 1/8-inch tape	1 75

SMOOTH-JAW PARALLEL PLIERS (these pliers can be used for all sizes of couplers), per pair 1 00

LEATHER BELTING.

Width.	Per ft.	Width.	Per ft.	Width.	Per ft.	Width.	Per ft.
1 inch	\$0 12	2 1/2 inches	\$0 36	4 inches	\$0 60	6 1/2 inches	\$1 00
1 1/4 inches	0 16	2 3/4 inches	0 40	4 1/2 inches	0 68	7 inches	1 08
1 1/2 inches	0 20	3 inches	0 44	5 inches	0 76	8 inches	1 24
1 3/4 inches	0 24	3 1/4 inches	0 48	5 1/2 inches	0 84	9 inches	1 40
2 inches	0 28	3 1/2 inches	0 52	6 inches	0 92	10 inches	1 50
2 1/4 inches	0 32	3 3/4 inches	0 56				

PRINTERS' BRUSHES.

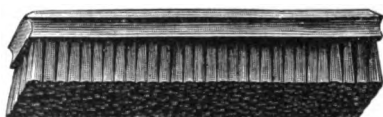

Lye Brush.

	—All Bristle—		—Tampico—	
	Per Doz.	Each.	Per. Doz.	Each.
Lye Brush, medium	\$5 00	\$0 50	\$3 50	\$0 40
Lye brush, large	7 00	0 75	4 50	0 50



Benzine Brush, oval back.

Benzine Brush, all bristle, oval back, genuine "pick" brush \$0 60



Benzine Brush, with handle.

Benzine Brush, all bristle, with handle \$0 40

PROOF AND STEREOTYPE BEATING BRUSHES.

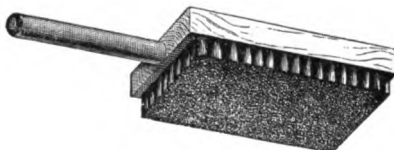

Ordinary Proof Brush \$1 50
Genuine Extra Stereotypers' Beating Brush, the best made, net . . . 7 00

LIQUID CEMENT BRUSH.

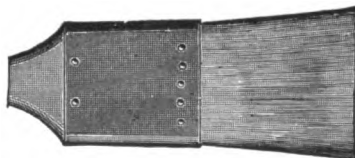

Made of French bristles, flat and double thick.

1 inch	\$0 30
1 1/2 inch	0 40
2 inch	0 55
3 1/2 inch	0 75

PRINTERS' DIVIDERS.



Useful for laying out paper, setting gauges and imposing plate forms.

Price \$0 85

INK KNIVES.

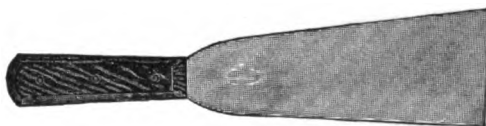

Style B.

6-inch blade, Style B \$0 60
 8-inch blade, Style B 1 00
 10-inch blade, Style B 1 60

WRENCHES.



8-inch \$0 75
 12-inch 1 00

PALLET INK KNIVES.



Square end.

6-inch blade \$0 50
 8-inch blade 0 70
 10-inch blade 1 00

PAPER FOLDERS.



Also used for feeding cylinder presses.

Steel, nickel-plated, 6 x 1 1/4 inches, each \$0 50
 Bone, each, 25 cents; per dozen 2 50

INK SLICE.

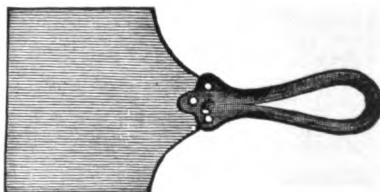

Brass handle, steel blade \$0 75

SCREW DRIVERS.



Each \$0 75

OVERLAY KNIFE.



In leather case, 6 x 1/4 inch, nickeled . \$0 60

ST. JOHN PAPER KNIFE.

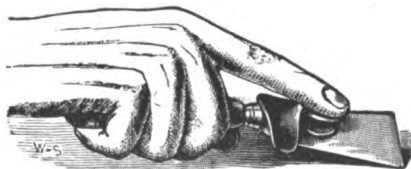

Made of fine steel and suitably pointed for cutting paper. Upon the back of the blade is fixed a broad guard, shaped to fit the finger, by which the operator is enabled to cut much faster and more easily than with a common knife.

Price \$0 50

TABLET KNIFE.



Made extra thin, for separating the tablets after they are removed from the press.

Price \$0 50

HICKORY SHOOTING STICKS.



This is the only safe shooting stick to use on the bed of a cylinder press.

Price, each, 8 cents; per dozen . . . \$0 85

GAUGE PINS AND GUIDES.

See explanation of Nos. below.

Original Steel Gauge Pins, Nos. 1, 2, 3, 4, per dozen	\$o 6o
Golden Steel Gauge Pins, Nos. 1, 2, 3, 4, 5, 6, per dozen	o 4o
Spring Tongue Gauge Pins, one size only, per dozen	1 2o
Flexible Side Gauge Pins, per dozen	o 6o
Perfect Register Gauge Pins, per set of three	1 25
Screw Adjusting Gauge Pins, one size only, per set of three	1 0o
Extension Feed Guides, per pair	1 0o
Cylinder Side Guides, each	o 5o
Extra Tongues for Spring Tongue, "Perfect," or Screw Adjusting Pins, per dozen	o 25
Gauge Pin Drawers (see illustration at bottom of page), each	o 25

EXPLANATION OF NUMBERS.

No. 1 gauges are 12 points high, with lip $\frac{1}{16}$ -inch long; No. 2, 15 points high, $\frac{1}{16}$ -inch lip; No. 3, 18 points high, $\frac{1}{16}$ -inch lip; No. 4, 12 points high, short lip; No. 5, 15 points high, $\frac{1}{8}$ -inch lip; No. 6, 12 points high, $\frac{1}{4}$ -inch lip. All gauges with tongues are 12 points high.

GOLDEN STEEL GAUGE PIN.

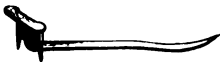

ORIGINAL STEEL GAUGE PIN.

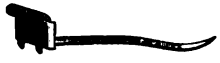

PERFECT REGISTER GAUGE PIN.



Pastes on like a quad, has a thin steel clip which strikes into tympan and prevents sheets from slipping under gauges, and is adjustable after pasting on.

FLEXIBLE SIDE GAUGE PIN.



May be placed directly under gripper finger without injury to gauge or displacing it. The sheet is fed to the curved spring arm. Made of fine thin steel, with teeth underneath to prevent sheet from getting under gauge.

CYLINDER SIDE GUIDE.

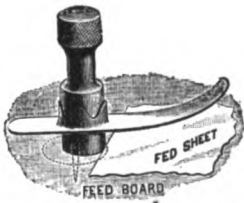

Secured to feed-board by the sharp point shown in outline in cut, which is placed at the side of pillar, so that hair adjustments may be got by simply turning the pillar to the desired position. The bendable brass tongue is adjustable in every direction.

SPRING TONGUE GAUGE PIN.



This is the most satisfactory gauge pin made. It meets almost every requirement of the pressman.

SCREW ADJUSTING GAUGE PIN.



The prong should be inserted a quarter inch below the feeding line and forced snugly home. The base may be secured to the tympan with paste or glue if desired. The adjustment is got by means of the screw and nut with absolute precision and without weakening the hold of the pin to tympan.

EXTENSION FEED GUIDES.

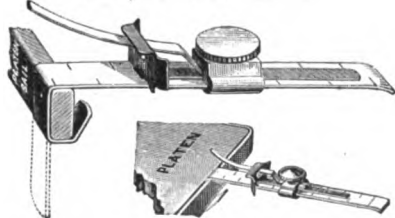

The cut shows the method of securing the guides between platen and platen bail, so that sheets may be fed below the lower edge of the platen.

GAUGE PIN DRAWER.

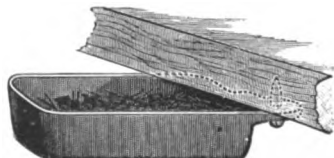

Screws on under the feed-board.

SUCCESS SAFETY BENZINE CAN.

Made of Brass.

By the use of this safety can, leakage of benzine or its vapor is prevented, as the stopper is automatically self-locking — always tightly closed when the can is not in use. The flow of benzine, naphtha or any other fluid is regulated by the pressure of the second and third fingers upon a circular plate on the nozzle; and the adjustment is so perfect that one can pour a single drop, or a full stream, at will. It is also neat and cleanly, for the hands are kept entirely free from contact with its contents. The patent improved stopper is as durable as it is simple. Made of the best material, and carefully finished and adjusted.

As a safeguard against loss by fire, this can is an economical and profitable "policy." Benzine is dangerous, but its use is divested of risk where this improved can is employed. It has been put to the test, and proved safe and serviceable in every respect. It may be overturned or placed in any position whatever, and the contents will not spill or overflow. There are no chains or exposed springs. Approved by the Board of Fire Underwriters.



Quart can \$0 75
 Gallon can 2 00

UNION STORAGE CAN.

For Holding Benzine or Oils.

It is strongly made of galvanized iron and is self-closing. There can be no evaporation, and no fluid can be spilled until the nozzle is opened by means of the spring. A very necessary article in all printing offices which are permitted to have one or more gallons of benzine on the premises.

Quite a saving in the cost of benzine and oils will be realized by purchasing in the quantities held by these storage cans, besides avoiding the inconvenience of sending out at frequent intervals to get the ordinary benzine can filled up.



1-gallon can \$2 00
 3-gallon can 2 50
 5-gallon can 3 00



UNION SAFE BENZINE CAN.

This is patterned after the original benzine can, with the addition of a circular plate around the head, near the vent, by means of which the valve is opened without wetting the fingers. When pressure is removed it closes automatically. The head is attached to the can with a chain, so that it cannot be lost when unscrewed for the purpose of filling with benzine.



Made of tin.
 Enameled red.

Holds one quart, each \$0 75

PRESS POINTS.

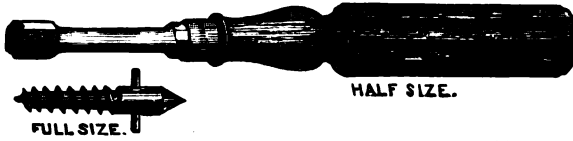

For inserting in wood furniture when sheets are printed for folding machine. Points are screwed into wood with wrench as far as the cross pin will allow, when they will be found to be correct height.
 Points, per dozen \$0 75 | Wrench \$0 75

DILLINGHAM PRESS PUNCH.

Patented March 2, 1897.

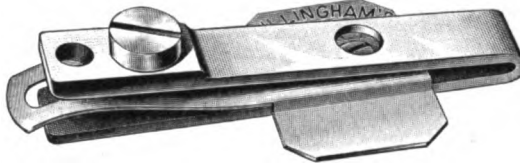

Is secured to the tympan of platen presses in same manner as a feed guide, and punches a clean hole in card or paper simultaneously with the printing on jobs which have a margin of one inch or more.

The method of working this punch is clearly shown in accompanying half-tone. The slightly curved spring is placed under the upper tympan sheet, and the sheet to be punched is fed over this curved spring and under the punch with no more trouble than in feeding to gauge pins. The punch is secured to the

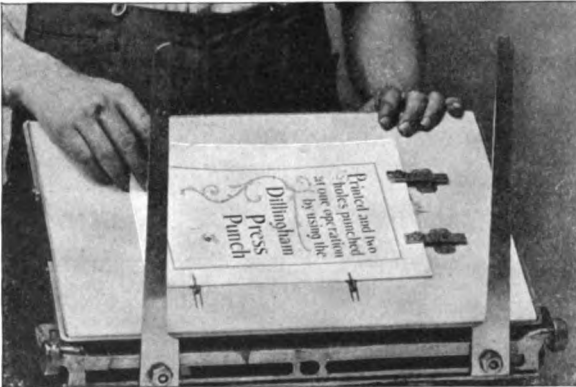

tympan by paste or glue or (better still) by

a mixture of paste and glue. Two or more punches can be used on one sheet. Punching and printing can be done simultaneously on a variety of work, such as window cards, programmes, orders of dance, souvenirs, etc. Made with large and small holes, as per diagram. The larger hole will be sent unless otherwise ordered.

Each, with directions, net \$1 25

PRESS PUNCH.



This punch is about one thirty-second inch lower than type, and can be locked up in a type form, thus enabling printers to punch holes in stock at the same time it is printed, without extra expense. A piece of 2-point brass rule should be cemented to the tympan sheet for the punch to strike on, and an opening left in the form opposite opening in base of punch to prevent it from becoming clogged. Made of best tool steel, tempered.

For 1/8, 3/16, or 1/4 inch hole, each \$1 00

MAHOGANY AND IRON STEREOTYPE BLOCKS.

Mahogany Blocks are made of the best San Domingo mahogany, thoroughly seasoned, and are first-class in every detail. All blocks are made to order at short notice.

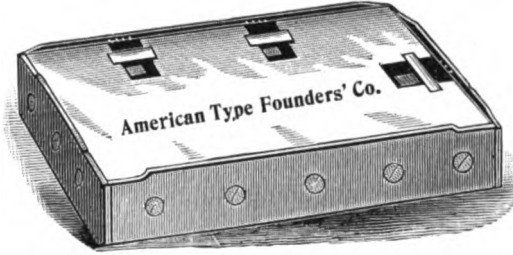

New Style Block, with Patent Side and End Hooks.

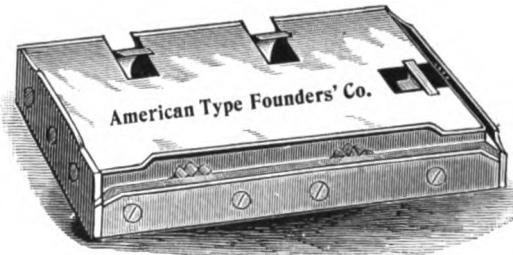

Improved Plain Old Style Block, with Patent End Hook.

IMPORTANT POINTS.

Do not order a set of blocks, nor make up a form of patent blocks for press, until you know the exact size of chase that must hold the blocks, and the thickness and position of its cross-bars. Ascertain also the exact size of paper for which the blocks are intended, and whether the leaves of paper, after printing, are to be cut or uncut, and to be sewed or stitched. In making up blocks, if paper is to be uncut and sewed, allow nothing for loss by waste on the fore edge; if it is to be side-stitched and trimmed, make suitable allowance for margin that will be concealed by wire stitching in binding.

CAUTION—To Avoid Errors.

In sending orders, give the size of each block outside, and also the size of largest and smallest plate to be worked, *measuring the back of the plate*; or add $\frac{3}{4}$ of an inch to the printing matter, as follows, viz.: If the matter is 3 x 5, the blocks should be $3\frac{3}{4}$ x $5\frac{3}{4}$ outside, the bevel on the plate being about $\frac{1}{8}$. The hook and pinion will take $\frac{5}{8}$ with a little allowance for taking the plate free. All blocks are made $\frac{3}{4}$ -inch thick, unless otherwise ordered.

WITHOUT END HOOKS, FOR PLATEN PRESSES.

To get the price of blocks with head brass, but no end hook, take the price of the next largest size in Price List. Add 50 cents each for extra hooks and pinions inserted in blocks.

SIZES.	Outside Dimensions of Blocks.	*Size of Smallest Plate including Bevel.	No. of Side Hooks.	Imp. Plain Old Style.	Patent New Style.	Patent New Style Iron.	Proper Number of Blocks to Work a Sheet of Paper.
Folio—							
Imperial	16 x 22½	14¾ x 21¾	4	\$5 00	\$6 25	\$16 00	4 blocks to 33 x 46
Super-Royal	13½ x 21½	12¾ x 20¾	4	4 55	5 70	15 00	2 blocks to 22 x 28
Royal	12½ x 19½	11¾ x 18¾	4	4 20	5 25	14 00	4 blocks to 26 x 40
Medium	11½ x 18½	10¾ x 17¾	4	3 90	4 80	13 00	4 blocks to 24 x 38
Quarto—							
Imperial	11 x 16	9¾ x 14¾	4	3 75	4 50	12 00	8 blocks to 33 x 46
Super-Royal	10½ x 13½	9¾ x 12¾	3	3 10	3 75	10 50	4 blocks to 22 x 28
Royal	9½ x 12½	8¾ x 11¾	3	2 95	3 50	10 00	8 blocks to 26 x 40
Medium	9 x 11½	7¾ x 10¾	3	2 80	3 30	9 50	8 blocks to 24 x 38
Octavo—							
Imperial	7¾ x 11	6½ x 9¾	3	2 65	3 10	9 00	16 blocks to 33 x 46
Super-Royal	6½ x 10½	5¾ x 9¾	3	2 50	2 90	8 50	8 blocks to 22 x 28
Royal	6 x 9½	4¾ x 8¾	3	2 40	2 75	8 00	16 blocks to 26 x 40
Medium	5½ x 9	4¾ x 7¾	3	2 20	2 60	7 75	16 blocks to 24 x 38
Demy	5¼ x 7¾	4 x 6½	3	2 20	2 45	7 50	32 blocks to 33 x 46
Duodecimo—							
Broad	5¾ x 6¾	4 x 5½	2	1 65	1 90	..	24 blocks to 23 x 41
16mo—							
Super-Royal	5 x 6½	3¾ x 5¾	2	1 50	1 70	..	16 blocks to 22 x 28
Medium	4½ x 6	3¾ x 4¾	2	1 40	1 60	..	32 blocks to 26 x 40
Demy	3¾ x 5¼	2½ x 4	2	1 30	1 50	..	32 blocks to 23 x 33
18mo—							
Medium	3½ x 5¾	2¾ x 4½	2	1 30	1 50	..	18 blocks to 19 x 24
32mo—							
Super-Royal	3 x 5	1¾ x 3¾	2	1 20	1 40	..	32 blocks to 22 x 28

* A block will take on a plate $\frac{1}{4}$ -inch smaller each way than its outside dimensions.

WITH END HOOKS, FOR CYLINDER PRESSES.

See "Caution" and other information on opposite page before ordering.

SIZE.	Outside Dimensions of Blocks.	*Size of Smallest Plate including Bevel.	No. of Side Hooks.	No. of End Hooks.	Imp. Plain Old Style.	Patent New Style.	Patent New Style Iron Blocks.	Proper Number of Blocks to Work a Sheet of Paper.
Folio—								
Imperial	16 × 22½	14¾ × 21½	4	3	\$7 25	\$8 50	\$21 00	4 blocks to 33×46
Super-Royal	13½ × 21½	12¾ × 20¾	4	3	6 80	7 95	19 50	2 blocks to 22×28
Royal	12½ × 19½	11½ × 18½	4	3	6 40	7 45	18 25	4 blocks to 26×40
Medium	11½ × 18½	10¾ × 17¾	4	3	6 10	7 00	17 25	4 blocks to 24×38
Quarto—								
Imperial	11 × 16	9¾ × 14¾	4	2	5 30	6 10	15 00	8 blocks to 33×46
Super-Royal	10½ × 13½	9¼ × 12¾	3	2	4 50	5 25	13 50	4 blocks to 22×28
Royal	9½ × 12½	8¾ × 11½	3	2	4 25	4 90	12 75	8 blocks to 26×40
Medium	9 × 11½	7¾ × 10¾	3	2	4 00	4 60	12 25	8 blocks to 24×38
Octavo—								
Imperial	7½ × 11	6½ × 9¾	3	1	3 30	3 80	10 75	16 blocks to 33×46
Super-Royal	6½ × 10½	5½ × 9¼	3	1	3 15	3 60	10 00	8 blocks to 22×28
Royal	6 × 9½	4¾ × 8¾	3	1	3 00	3 40	9 50	16 blocks to 26×40
Medium	5½ × 9	4¼ × 7¾	3	1	2 85	3 25	9 00	16 blocks to 24×38
Demy	5¼ × 7¾	4 × 6¾	3	1	2 70	3 10	8 50	32 blocks to 33×46
Duodecimo—								
Broad	5¼ × 6¾	4 × 5½	2	1	2 05	2 45	..	24 blocks to 23×41
16mo—								
Super-Royal	5 × 6½	3¾ × 5¾	2	1	1 95	2 30	..	16 blocks to 22×28
Medium	4½ × 6	3½ × 4¾	2	1	1 85	2 15	..	32 blocks to 26×40
Demy	3¾ × 5¾	2½ × 4	2	1	1 75	2 00	..	32 blocks to 23×33
18mo—								
Medium	3½ × 5¾	2¾ × 4¾	2	1	1 75	2 00	..	18 blocks to 19×24
32-mo								
Super-Royal	3 × 5	1¾ × 3¾	2	1	1 65	1 85	..	32 blocks to 22×28

* A Block will take on a plate ¼-inch smaller each way than its outside dimensions.

RATCHETS FOR STEREOTYPE BLOCKS.

Brass, each \$0 50
 Steel, each 0 75

EXTRAS FOR STEREOTYPE BLOCKS.

Steel Pinions, each \$0 15
 Hooks, each 0 10

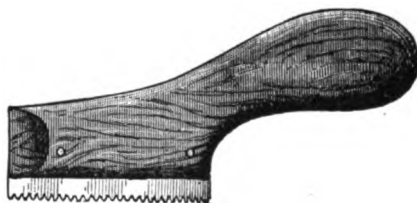

STEREOTYPE SECTIONAL METAL BLOCKS

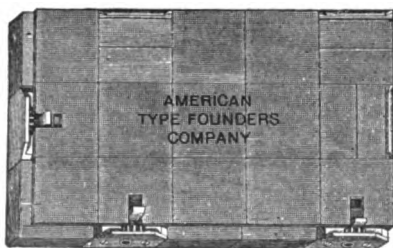

Consist of metal sections, made up of pieces 2×4, 2×8, 4×4, 4×8, and 8×8 ems Pica. Hooks are inserted in the largest sections, which may be arranged on any part of the block, and can be adapted for bed and platen or cylinder presswork. With an assortment of the sections or furniture, the printer may, by a proper combination, prepare a set of blocks to take on a page of any size. To extend size of sectional block, in case there is a shortage of sections, metal furniture not exceeding two ems Pica wide may be used.

Sections with hook, each \$1 10
 Brass catches, each 0 15
 Sections or furniture, per pound 0 25

WETTER NUMBERING MACHINES.

THE BETTER WETTER.

The latest successful development in Numbering Machines, for use with or without type on printing presses. This is the only typographic numberer that prints nothing but the figures, without "No.," a period, or any other affix or suffix intended to act as plungers or to prevent the printed sheet from being smeared by the revolving figures. The pressure of the platen or cylinder on the figures operates the mechanism which changes the numbers and also an ingenious bearer, which raises automatically and holds the printed sheet off the figures while they are changing. This bearer does not print on or indent the paper.

The Better Wetter is made with that perfection in construction and materials which have made all "Wetter" Machines famous.

This is the smallest machine of its kind, being 3/4-inch wide, the length depending upon the number and thickness of figures required. *Type can be set close up to the machine on all sides.*

Four regular styles of figures made. Styles J and K kept in stock. Styles L and M furnished at short notice.

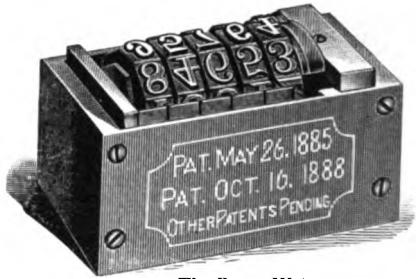

The Better Wetter.

Style J **1234567890** Style K **1234567890**

These Styles used on both the Better Wetter and No. 1 Wetter.

Style L **1234567890** Style M **1234567890**



No. 1, actual size, Style J.

No. 1 WETTER NUMBERING MACHINE.

This is the regular machine, of which thousands are in use all over the world. Permits printing and numbering at one impression. Can be used on any make of press. Numbers automatically from the unit to its full numerical capacity. It can be used with or *without* the character "No." Other characters, such as a star, parenthesis, fist, cipher, or any letter, can be used to either precede or follow the figures. Produces clean, smooth and distinct figures. Styles of figures J and K are most used, and are kept in stock, but Styles L and M can be furnished upon short notice.

The 5-wheel style J machine occupies a surface space of 3/4-inch in width by 1 1/4 inches in length.

PRICES OF No. 1 WETTER AND THE BETTER WETTER.

Style J or K or L or M, five wheels, numbering up to 99999 \$25 00
 Style J or K or L or M, six wheels, numbering up to 999999 28 00
 Style J or K or L or M, seven wheels, numbering up to 9999999 31 00

In ordering state which machine is required, and state style of figure and number of wheels desired. Unless otherwise ordered, the 5-wheel style J Better Wetter will be sent.

SPECIAL WETTER NUMBERING MACHINES.



No. 3.

See description and prices on opposite page.

Made to Order only.

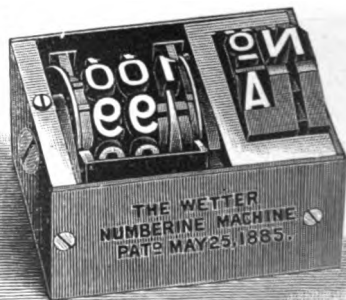

No. 4.

No. 3. WETTER MACHINE FOR SMALL RAILROAD WORK.

(See illustration on opposite page.)

Numbers on extreme end, as shown on diagram. Plunger is at foot of machine, and does not strike the printed sheet. Occupies only 3/8-inch space on ticket when locked in form.

1234567890

Style of Figures for No. 3 Machine.



No. 3.	5-wheel (figures as above)	\$25 00
No. 3.	6-wheel	28 00
No. 3.	7-wheel	31 00

No. 4. WETTER MACHINE FOR NUMBERING CASH SALE SLIPS.

(See illustration on opposite page.)

Made to number automatically from 100 to 1, or 50 to 1. Object of numbers running backward is to avoid expense of collating sheets after printing. Can be made to number forward. After printing to 100 or 50 they commence again at 1. Plunger wheel can be made with a letter wheel to print A, B, C, D, E, F, G and H, or letter slides may be used in plunger, and any of these letters or the character "No." can be used at will by turning the wheel until the desired letter is on top.

Price, 3-wheel, with letter wheel \$25 00

No. 5. WETTER DUPLEX MACHINE FOR NUMBERING DUPLEX RAILROAD TICKETS.

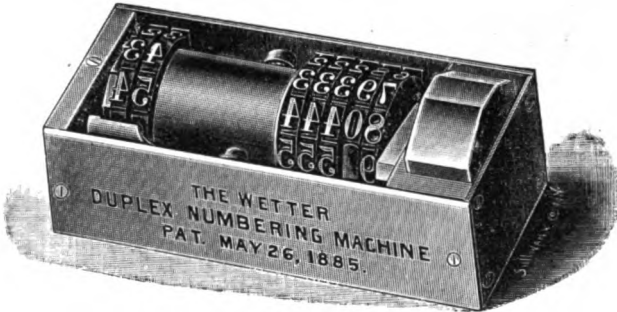

Numbers tickets on both sides and also on stub at one impression. Ticket numbers generally run from 1 to 100 or 0 to 99, and changes consecutively the book number which runs from 1 to 9999 or 1 to 99999. Can be arranged to change once at every one hundred impressions of ticket number, or can be made stationary, so that changes can be made by hand. There are three machines to a set—one for stub and one for each side of the ticket, to be used in same manner as ordinary Wetter Numberer, needing no attachment of any kind.

Set of three machines, net \$120 00

No. 7. WETTER MACHINE FOR NUMBERING BOND COUPONS.

Numbers with or without serial attachment. 3/8-inch wide, and can be used on narrowest bond coupons. Letter wheel can be placed on end to indicate serial No. A, B, C, D, E, F, G, H, I or J; or the serial letter or character "No." can be placed close to figure, thus—A1.

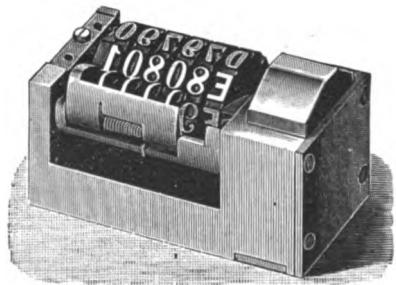

Price, 5-wheel	\$25 00
Price, 6-wheel	28 00
Price, 7-wheel	31 00

No. 8. WETTER MACHINE FOR NUMBERING LOTTERY TICKETS.

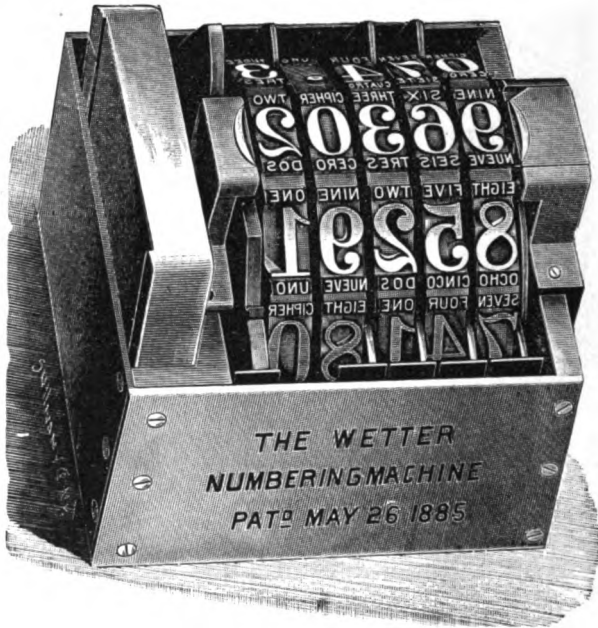

These are considerably more than type high, and the printing-press bed must be sunk or cut out so it will take in a thickness of two inches. We can supply presses for this purpose. Denominations of the figures can be spelled out under and over the figures in any language. Parenthesis marks can be placed at each side of a figure, thus—(1) to (9). At changing to 10 the parenthesis is moved back one step, and may be changed to include all figures until the full number (9999) is printed. Prices on application. Send full details and samples of work required. We show example of the figures used.

SIX SEVEN EIGHT NINE CIPHER
(67890)
 SEIS SIETE OCHO NUEVE CERO

No. 9. WETTER MACHINE FOR PRINTING NUMBER AND DATE SIMULTANEOUSLY.

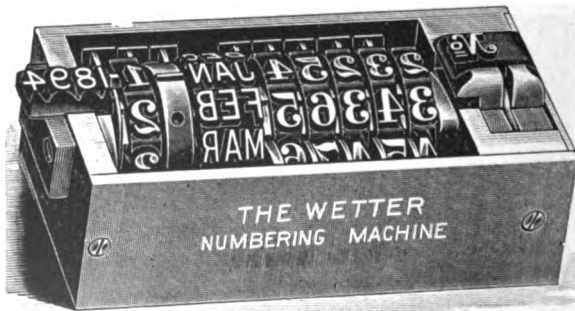

Designed for printing tickets, envelopes, or documents requiring both date and number, such as church envelopes, thus—**25098 JAN 23-1896** Works automatically, Machine. Price, 5-wheel, wheels, and year plates, net \$38 00

DURANT COUNTER.



This counter gives perfect satisfaction. It is as reliable as it is strong, durable, and attractive.



No. 2, with Alarm Gong.

- No. 1, 4-dial, counts 10,000 . . . \$ 8 00
- No. 2, 5-dial, counts 100,000 . . . 10 00
- No. 3, 6-dial, counts 1,000,000 . . . 12 00
- No. 2A, 5-dial, with 4-inch gong, to give alarm at each 100 15 00

DOUBLE DIAL ALARM COUNTER.

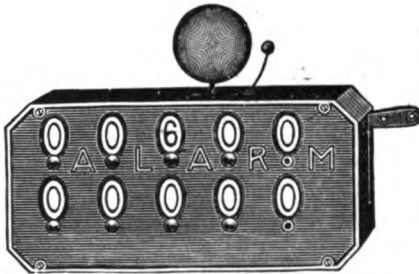

This counter is so constructed that the lower dials show the number run like the usual counter. The upper dials are the alarm device, and can be set (instantly without taking from the case, by thumb-screw or key) to any desired number you wish to print, and when that number is printed the bell will ring. To illustrate: Set the alarm on 600, if that is the number you wish to run, with lower dials on ciphers. First revolution of the machine the lower dials will show 1, and the upper dials 599 or one less, and so on until 600 is run, when the upper dials will stand at (000) ciphers and the bell will ring. Any time you look at the counter

it will show how many yet to run. Perfectly simple in construction. No more springs are used than in an ordinary counter, and all are made of best piano wire. This counter has an iron case, and very legible figures.

- No. 1. Double Dial Alarm, 5x8, 1/2-inch figures, registering 100,000 \$15 00

AMERICAN COUNTING MACHINE.

Has no superior for strength, accuracy, reliability. Can be set to zero, or any number, with the fingers with the greatest ease. There are no springs inside this counter, and all movements of the figure-dials are so positive that it is impossible for them to miss registering. The case may be screwed to the wall or on a table, and the lever can be set to any position, and will work from front or back. The figures are cast solid, nickel-plated, and are very legible.

Price \$10 00



GERMAN PRINTING INKS.

These Inks are made by one of the most extensive Ink manufacturers in the world, and have a world-wide reputation for quality and uniformity. We use them exclusively on our own specimen printing. Inks for special work and to match all colors furnished to order expeditiously.



Factories in which Albert Nathan & Co.'s Inks are made. Every ingredient used in high-grade Inks is made in these factories.

SMALLEST PACKAGES SOLD.

News Ink in packages as per Price List below.

- 2 lb.—Inks listed at 25 cents per lb.
- 1 lb.—Inks listed at 50 cents per lb.
- ½ lb.—Inks listed at 75 cents per lb.
- ¼ lb.—Inks listed at \$1 00 per lb. and over.

N. B.—All Inks listed at \$1.50 and over supplied in ¼-lb. tubes if so ordered, but at a lesser discount than is allowed on Inks sold in cans.

SUPERIOR NEWS INKS.

	5 and 10 lb. cans.	28 and 56 lb. cans.	112 lb. barrels.	224 lb. barrels.	450 lb. barrels.
For hand presses, per lb.	\$0 20	\$0 15			
For flat-bed presses, "	0 18	0 14	\$0 13	\$0 12	\$0 12
For perfecting presses, "			0 13	0 12	0 12

BLACK INKS.

	Per lb.		Per lb.
Engraver's Wood-cut Proof Black	\$8 00	Union Black, I, for half-tones	\$1 50
Extra Fine Union Black, E, for half-tones	5 00	Union Black, I, job	1 50
Extra Fine Union Black, E, cut and job	5 00	Insurance Policy Black	1 00
Fine Union Black, F, for half-tones	3 00	Columbian Black, H, for half-tones	1 00
Fine Union Black, F, cut and job	3 00	Fine Book and Job, K	1 00
Gloss Black	2 00	Brilliant Black, L, job	0 75
Fine Cut, G, for half-tones	2 00	Brilliant Black, L, book	0 75
Fine Job and Cut, G	2 00	Job Ink, M	0 50
		Book Ink, M	0 50
		Book Ink, N	0 25

SPECIAL BLACK INKS.

- Fast Lustra Black, for printing line and half-tone cuts, with type, on ordinary news paper on the fastest web presses (smallest quantity sold, 28 lbs.) \$0 50
- Lustra Black, for printing half-tones, with type and line cuts, on cheap papers on perfecting presses, speed about 5000 per hour (smallest quantity sold, 28 lbs.) 0 45
- Niagara Black, for printing half-tones, with type and line cuts, on cheap papers on flat-bed presses (smallest quantity sold, 10 lbs.) 0 40

BLUE- AND GREEN-BLACK INKS.

Bronze Blue-Black, light	\$2 50	Blue-Black, dark	\$1 50
Bronze Blue-Black, medium	2 00	Fine Green-Black	2 00

SPECIAL FAST-PRESS COLORS.

These are for use on colored supplements of newspapers printed on the fastest web presses. Smallest quantity sold, 28 lbs.

	Per lb.		Per lb.
Fast-press Red	\$1 25	Fast-press Green	\$1 00
Fast-press Blue	1 00	Fast-press Yellow	0 85

RED INKS.

Madder Lake	\$10 00	Carmine Vermilion	\$4 00
Geranium Carmine, 00	10 00	Gloss Red	3 00
Geranium Carmine, 1	8 00	Antique Red (for old-style red and black effects)	3 00
Geranium Lake, dark	5 00	Brilliant Red, dark	3 00
Geranium Lake, medium	5 00	Brilliant Red, medium, Lake shade	2 00
Geranium Lake, light	5 00	Brilliant Red, light	1 00
Bronze Carmine	5 00	Paris Lake	2 50
Bronze Red	4 00	Hamburg Red	2 50
Levantine Red	5 00	Label Red	2 00
Claret Color	5 00	Chinese Vermilion	2 00
Nassau Lake	4 50	Brilliant Lake, B	1 50
Scarlet Lake	4 00	Brilliant Lake, G	1 50
Rose Lake, dark	4 00	Deep Red	1 50
Rose Lake, medium	3 00	Granat Vermilion	1 00
Rose Lake, light	3 00	Poster Red	0 50
Deep Cherry	4 00	Poster Orange	0 50
Crimson Lake	4 00		

BLUE INKS.

Blue Lake, dark	\$5 00	Imperial Blue	\$3 00	Brussels Blue	\$2 50
Blue Lake, light	5 00	Gloss Blue	3 00	Oriental Blue	2 50
Peacock Blue	4 00	Bronze Blue, No. 1	2 50	Marine Blue	2 00
Milori Blue	3 00	Bronze Blue, No. 2	2 50	Label Blue	2 00
Ultramarine, dark	3 00	Deep Br'ze Blue, No. 1	2 50	Deep Blue	1 50
Ultramarine, light	1 50	Prussian Blue	2 50	Poster Blue	0 50

GREEN INKS.

Brilliant Green, light \$5 00	Bronze Green \$4 00	Silk Green, light \$1 50
Brilliant Green, deep 5 00	Green Lake 3 00	Olive Green 2 00
Victoria Green, dark 5 00	Gloss Green 3 00	Poster Green, light 0 50
Victoria Green, light 4 00	Silk Green, dark 2 00	Poster Green, dark 0 50
Viridin Blue 5 00	Silk Green, medium 2 00	

BROWN INKS.

Brown Lake \$4 00	Gloss Brown \$3 00	Ochre \$1 00
Photographic Brown 3 00	Velvet Brown 2 50	Poster Brown, dark 0 50
Virginia Brown 3 00	Terra di Sienna 2 00	Poster Brown, light 0 50
Bismarck Brown 3 00	Mahogany Brown 2 00	

YELLOW INKS.

Chrome Yellow, deep \$2 00	Zinc Yellow \$2 00	Label Yellow \$2 00
Chrome Yellow, light 2 00	Persian Yellow 2 00	Yellow, medium 1 00
Chrome Orange 2 00	Sulphur Yellow, dark 2 00	Poster Yellow 0 50

PURPLE INKS.

Violet Lake, reddish \$10 00	Brilliant Violet \$4 00
Violet Lake, bluish 8 00	Violet No. 1 4 00

GOLD INK.

Pale Gold \$5 00	Rich Gold \$5 00
----------------------------	----------------------------

WHITE INKS.

Ex. Fine Body White (prints white) \$1 50	Fine White, for tints \$1 00
Poster White \$0 50	

TINT INKS.

Any shade (twelve shades kept in stock, as per Ink Specimen Book) \$1 00

COPYABLE INKS.

Purple	Per lb. \$5 00	Red	Per lb. \$5 00	Scarlet	Per lb. \$5 00
Black	5 00	Blue	5 00	Green	5 00

BRONZE INKS.

Bronze Carmine	\$5 00	Bronze Green	\$4 00	Bronze Blue No. 1	\$2 50
Bronze Red	4 00	Deep Br'ze Blue No. 1	2 50	Bronze Blue No. 2	2 50

GLOSS INKS.

Gloss Red	\$3 00	Gloss Green	\$3 00	Gloss Black	\$2 00
Gloss Blue	3 00	Gloss Brown	3 00		

TYPEWRITER-EFFECT INKS.

Blue Typewriter	\$2 50	Green Typewriter	\$2 50
Purple Typewriter	2 50		

THREE-COLOR PROCESS INKS.

Three-color Process Red	\$4 50	Three-color Process Yellow	\$3 00
Three-color Process Blue	4 00		

BRONZE SIZE.

Yellow	\$1 50
White, for silver bronzes	1 50

REDUCING VARNISHES.

FOR REDUCING COLORED AND FINE BLACK INKS.

Pure Linseed, bleached, A, very soft	Per lb. \$0 50	Per gal. \$2 25
Pure Linseed, bleached, B, soft	0 55	2 25
Pure Linseed, bleached, C, medium	0 60	2 50

ORDINARY, FOR REDUCING BLACK INKS.

Ordinary	\$0 30	\$1 00
--------------------	--------	--------

GLOSS VARNISHES.

Transparent Gloss Varnish, for mixing into inks	Per lb. \$1 50
Body Gloss Varnish, for printing over black and colored inks	1 50

DRYERS.

Body Dryer, will not reduce consistency or body of inks	\$1 50
Fluid Dryer	1 50

NOTE—From one to two per cent. of above dryers can be safely used in colored inks, and from three to eight per cent. in black inks.

BRONZE POWDERS.

Extra Fine Brilliant Rich Gold No. 1	Per oz. \$0 40	Per lb. \$3 50
Extra Fine Brilliant Pale Gold No. 1	0 45	4 50
Extra Fine Brilliant No. 1, Crimson, Copper, Fire or Green	0 45	4 50
Extra Brilliant Rich "Electra" Gold No. 2	0 35	3 00
Extra Brilliant Pale "Electra" Gold No. 2	0 40	4 00
Brilliant Pale Gold No. 3	0 25	2 00
Brilliant Rich Gold No. 3	0 25	2 00
Brilliant No. 3, Crimson, Copper, Fire or Green		3 00
Rich or Pale Gold, grade A		1 00
Rich or Pale Gold, grade B		1 25
Silver No. 1	0 50	5 00
Silver No. 2	0 40	3 50
Silver No. 3	0 25	2 50
Aluminum	0 40	4 00
Patent Bronzes (Light Blue, Dark Blue, Blue-Green, Deep Green, Sea-Green, Yellow-Green, Amaranth and Violet)	0 40	4 00

CHESAPEAKE ECONOMY COMPOUND.

The Effective Ink Reducer for both Lithographic and Letter-press Inks.

IT IS PURE.—Chesapeake Economy Compound is absolutely free from mineral petroleum products or acids of any kind, and is perfectly safe. Varnishes may be added, if required.

IT HELPS INKS.—Any kind or color of ink mixed with Chesapeake Economy Compound will not dry on forms or rollers, and will not skin when exposed to the air. Upon being mixed with ink, Economy Compound becomes thoroughly identified with it, and with less weight of ink a solid, sharp print is obtained. Inks mixed with Economy Compound will cover 30 per cent. more paper than if used without it.

IT PREVENTS TROUBLE.—Coated and surface papers will not pull if printed with ink mixed with Economy Compound, and the use of the Compound tends to prevent off-set and to make inks dry quicker on paper. It is not necessary, as a rule, to wash up rollers at night when inks are mixed with Economy Compound, as the inks will not dry on rollers. Economy Compound keeps lithographic stones in good condition, and inks mixed with it lift well from the stone.



1-pound cans	\$0 75
5-pound cans	3 25
10-pound cans	6 00
25-pound cans	13 75
50-pound cans	25 00

A FEW OPINIONS.

The Pioneer Press Co., St. Paul, Minn.: "Ship us 50 pounds Economy Compound, same as furnished heretofore."

P. F. Pettibone & Co., Chicago: "We have been using Economy Compound in our press room for some months, and find it a very fine article indeed."

John A. Lowell & Co., Boston: "We find Economy Compound most excellent for printing heavy black forms on enameled or coated stock, enabling us to turn out the work quickly and without off-setting."

Oxford Publishing House, Baltimore, Md.: "Economy Compound is doing more than is claimed for it. We get full 30 per cent. more from our inks and a much better result in the way of solid color than we did before using it, and the fact that long runs can be left over night ready to start in the morning without washing up is a great saving of both time and ink, especially on hurried work. We have used it for six months and would not be without it."

G. H. Dunston, Buffalo, N. Y.: "Economy Compound is the best reducer we have ever used, especially in cases where ink has hardened. This formerly caused us trouble and loss, as it was frequently necessary to throw away such ink; but with this reducer we can put the ink in proper condition for use."

Matthews-Northrup Co., Buffalo, N. Y.: "As good a reducer as we have ever used."

Magee Printing House, Philadelphia: "It does everything claimed for it. We are very much pleased with it."

INKOLEUM.



A liquid preparation of world-wide fame for reducing and refining printing inks without impairing the color. It makes intractable inks work smoothly on discs, cylinders and rollers, and, mixed with caked inks, makes them useful again. Handy to have in the press room, as it is invaluable in cases of emergency.

Per bottle, half pound	\$0 50
----------------------------------	--------

EUREKA TYPE WASH.

The most effective powder preparation for removing ink from type rollers and plates. Does not injure brushes, corrode type, nor hurt the hands. Directions on every package. While its action is gentle, it is quite as effective for cleaning as the most powerful lye. One pound of powder will make eight gallons of washing fluid.

- 1-pound cans, each \$0 20
- 5-pound cans, each 0 75
- 10-pound cans, each 1 25
- 50-pound tubs, each 5 00



INK AND ROLLER CABINETS.



A very necessary article of printing-office furniture. The use of it will result in a saving of ink and rollers, which will speedily pay for the cost of cabinet.

- No. 1, with shelf for ink, shelf for brayer and ink slab, and brackets to hold 6 eighth and 6 quarto rollers \$6 50
- No. 2, with shelf for ink, shelf for brayers and ink slabs, and brackets for 6 each eighth, quarto and half-medium rollers 9 50
- No. 3, with shelf for ink, shelf for brayers and ink slabs, and brackets to hold 12 each eighth, quarto and half-medium rollers 13 00

ADAMSON DISC COVER.

We have sold some hundreds of these useful Disc Covers and none have been returned. Recommended as savers of ink and time, and approved by all purchasers.

Makes Copying Inks Work Easy.

Cold iron and copying inks repel each other. To avoid trouble, slip an Adamson Disc Cover over your disc. It is made of special cloth, lined with rubber. Iron dries the ink, deadens it, wastes it. The cloth disc gives good distribution, becomes saturated with ink like a stamp pad, and saves 50 per cent. of ink. When job is done, lift off disc cover. Saves washing time, and all the ink in cover is available the next time you use it. In ordering send the exact size of ink disc.

Owing to the limited space between edge of disc and chase-latch, these discs cannot be used on Golding Jobber and Pearl Presses.

- For press 7 × 11 inches, net . . . \$1 75
- For press 8 × 12 inches, net . . . 1 75
- For press 9 × 13 inches, net . . . 1 75
- For press 10 × 15 inches, net . . . 2 25
- For press 11 × 17 inches, net . . . 2 75
- For press 12 × 18 inches, net . . . 2 75

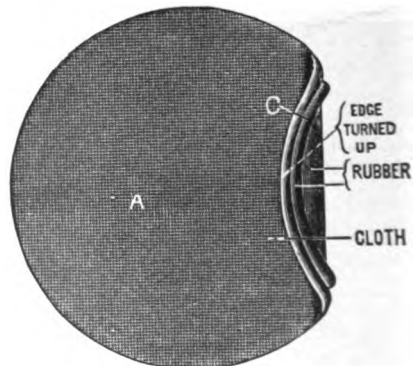

- For press 13 × 19 inches, net . . . \$2 75
- For press 14 × 20 inches, net . . . 3 00
- For press 14½ × 22 inches, net . . . 3 25

Send exact size of disc when ordering. Directions with each Disc Cover.

HERCULES LIQUID OVERLAY.

A substitute for paper overlays, giving a finer, quicker make-ready, and saving lots of time and tedious work. It is put on thinly with a camel's-hair brush, and the first application should be allowed to dry before putting on another, if the first is not heavy enough. It dries very quickly. If the Liquid Overlay is put on too thickly, the overlay is reduced by scraping it with fine emery cloth.

Each pressman should have an independent supply in a small phial suitable for carrying in the vest pocket.

4-ounce bottle, net \$1 25
 8-ounce bottle, net 2 00

Full directions with each bottle.



BURBANK'S EMBOSsing COMPOSITION.

This is an approved and satisfactory liquid chemical preparation for making counter dies for embossing, which, after exposure for a few minutes

to light and air, hardens into a stone-like substance, making a perfect counterpart.

Specially adapted for making counter dies for Hand and Power Embossing Presses listed in this Price List.

It is easily applied, according to directions printed on every can, and greatly simplifies and cheapens the process of embossing.

Price, net \$0 75



**LAWLOR'S
 "EMBOSSING MADE EASY."**

This book explains lucidly and gives directions for several processes of embossing. It is the standard work on the subject.

Price, net \$1 00

"BENTROVATO."

[TRADE MARK.]

Dispels Electricity from Paper on Printing Presses.

A chemical fluid preparation which, applied in a small quantity to the tympan sheet by means of a sponge, cloth or cotton waste, effectually dispels the electricity generated in cylinder presses—a difficulty which results in serious losses to printers.

In all offices where there is a tendency toward this trouble, a bottle of "Bentrovato" will prove as valuable as the proverbial "stitch in time."

"Bentrovato" is used in a majority of the larger printing offices throughout the United States.

American Type Founders' Co.: Please send me at once by American Express one bottle of "Bentrovato." I should not like to be without it, even if it cost \$10 per bottle. Our devil knocked over the first bottle you sent us. I bought it with no faith, simply because I was willing to try anything. Our paper was as if possessed by ten thousand devils. The trouble ended at once and completely with the use of the "Bentrovato."—WALTER B. SHEPPARD, publisher of the Pan Yan Democrat (founded in 1818).

Per bottle, net \$0 50

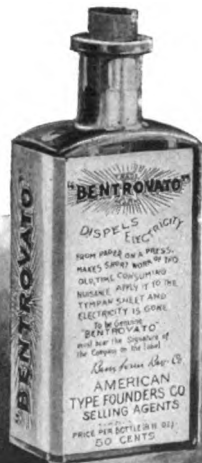

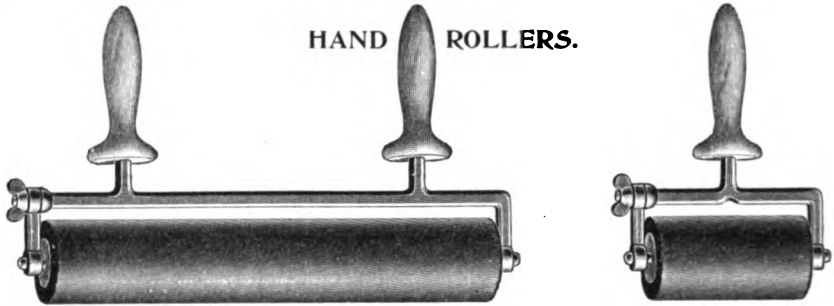

HAND ROLLERS.

When complete rollers are ordered, we furnish them with the best roller composition. There is no economy in cheap roller composition.

Number of Handles.	Frame and Handle.	Roller Complete.	Extra Stock.	Number of Handles.	Frame and Handle.	Roller Complete.	Extra Stock.
6 in. 1 . . .	\$1 25	\$1 85	\$0 40	24 in. 2 . . .	\$3 25	\$5 05	\$1 00
8 in. 1 . . .	1 50	2 30	0 40	26 in. 1 . . .	3 75	6 35	1 15
10 in. 1 . . .	1 75	2 75	0 60	30 in. 1 . . .	4 50	7 50	1 25
12 in. 1 . . .	2 00	3 20	0 60	36 in. 1 . . .	5 00	8 60	1 40
14 in. 2 . . .	2 25	3 65	0 70	40 in. 1 . . .	5 50	9 50	1 50
16 in. 2 . . .	2 50	4 10	0 70	44 in. 1 . . .	6 00	10 40	1 60
18 in. 2 . . .	2 75	4 55	0 80	50 in. 1 . . .	6 50	11 50	..
20 in. 2 . . .	3 00	5 00	0 80	54 in. 1 . . .	7 00	12 40	..

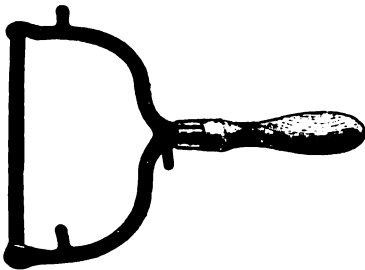

PROOF ROLLERS.

Malleable iron frame, wooden core and handle.

	Frame and Core.	Roller Complete.
6-inch	\$1 00	\$1 50
8-inch	1 05	1 60
10-inch	1 10	1 75
12-inch	1 25	2 00

ROLLER COMPOSITION.

We recommend the use of the best composition only. Bingham's Composition is sold f. o. b. Chicago, Crutsinger's Composition f. o. b. St. Louis, and Van Bibber's Composition f. o. b. Cincinnati.

Bingham's Standard, per lb.	\$0 30
Bingham's Durable, per lb.	0 50
Gem, for the Northwest, per lb.	0 40
Crutsinger's Eagle, per lb.	0 35
Crutsinger's Peerless, per lb.	0 45
Van Bibber's Roller Composition	0 30
Van Bibber's Rough and Ready Roller Composition	0 35

PRICES FOR CASTING JOB PRESS ROLLERS.

	Size Press.	Each.		Size Press.	Each.
Eighth Medium	7 x 11	\$0 40	Quarto Medium	12 x 18	\$1 00
Eighth Medium	8 x 12	0 40	Half Medium	13 x 19	1 00
Eighth Medium	9 x 13	0 45	Half Medium	14 x 20	1 10
Quarto Medium	10 x 15	0 80	Half Super-Royal	14 1/2 x 22	1 25
Quarto Medium	11 x 17	1 00			



ROLLER COMPOSITION KETTLE.

Consists of two separate kettles, the inner one to hold the composition, the outer to hold water, which prevents the composition from burning. Made of heavy tin, with copper bottom to the water kettles.

1 gallon, net	\$3 50
2 gallons, net	5 00
3 gallons, net	6 50

Other sizes made to order.

STEEL ROLLER SUPPORTERS.

The best bearers yet devised for job presses. They only take up a quarter of an inch of the inside space of a chase, ease the pressure of the rollers on the form, prevent over-inking, equalize the impression, and save the rollers from cutting, as they are 3/8-inch wide on top.

Per pair.

For 5 × 9 chase	\$0 35
For 7 × 11 chase	0 40
For 8 × 12 chase	0 45
For 10 × 15 chase	0 50
For 11 × 17 chase	0 60
For 13 × 19 chase	0 75
For 14 × 20 chase	0 90
For 14 1/2 × 22 chase	0 90

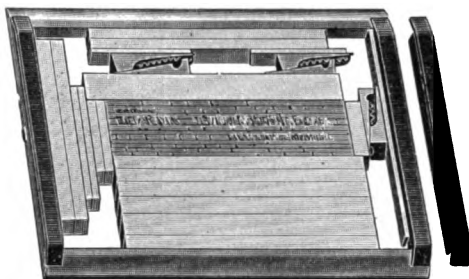

ELM CITY BRONZING PAD.



This has become an article of necessity in the press room. Saves time and bronze, and insures clean work.

Large, 2 1/2 × 6 inches	\$2 50
Small, for light work, 2 1/2 inches square	1 50

BRONZING MITTEN.



A convenient appliance for bronzing. Made from sheep's wool, with strong cloth back, and is impervious to bronze.

Each	\$0 50
----------------	--------

For Bronze Powders, Bronze Size and Gold Ink, see pages 887 and 888.

MOVABLE DRYING RACKS.

The frames of both these racks are of hard wood, bolted together, and mounted on strong casters, so that they can be easily moved when loaded. The shelves of the Chicago Rack are framed all around with hard wood, while those of the New York Rack are framed on ends only.



No. 1 New York Drying Rack.

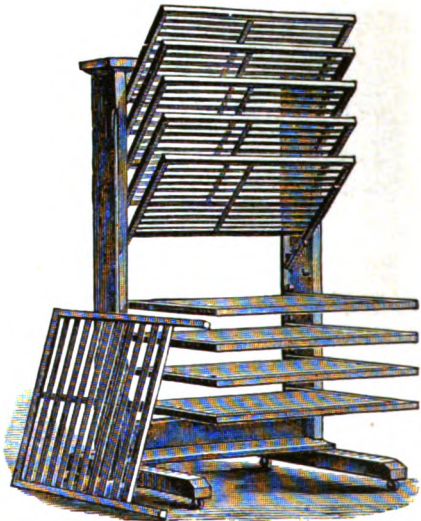

No. 6 Chicago Drying Rack.

NEW YORK DRYING RACKS.

- | | |
|---|---|
| No. 1, 20 shelves, each 24 x 36 in. . . \$14 00 | No. 3, 20 shelves, each 28 x 42 in. . . \$20 00 |
| No. 2, 30 shelves, each 24 x 36 in. . . 20 00 | No. 4, 30 shelves, each 28 x 42 in. . . 28 00 |

The No. 1 rack (the cheapest) gives a drying area of one hundred and twenty square feet, while actually using only six square feet of your costly floor space.

CHICAGO DRYING RACKS.

- | | |
|--|--|
| No. 5, 12 shelves, each 2 x 2 feet . . \$14 00 | No. 6, 10 shelves, each 2 x 3 feet . . \$18 00 |
| No. 7, 10 shelves, each 2 1/4 x 4 feet . . \$23 00 | |

This rack is the most substantial movable drying rack made. Although it has fewer shelves than a New York, the extra space between the shelves is a distinct advantage, as on small jobs the sheets can be handled without moving the shelf on which they are placed. When not in use the shelves may be put out of the way, as illustrated in cut.

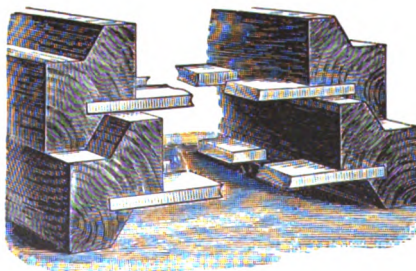

Figure 2. End View of Interlocking Device.

BEST RACKS FOR LARGE EDITIONS.

On opposite page we describe a patented rack which has saved large firms thousands of dollars per year by enabling them to utilize their floor space to the utmost extent, making slip-sheeting unnecessary on very many jobs and preventing wastage by handling sheets. The interlocking device and method of inserting the slats into the sides is very plainly illustrated in Figure 2. No large establishment can afford to use wall-racks now that these effective racks, used in connection with trucks, will save their cost every month in the year.

KÖERNER'S PATENT INTERLOCKING DRYING RACKS.

(United States Patent, No. 392,735; Canadian Patent, No. 28,739.)

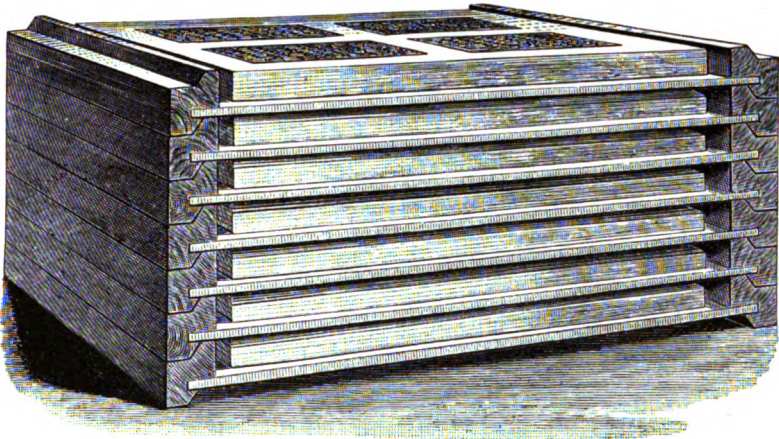

Fig. 2. Interlocking Racks Stacked with Paper, Straight and Rigid.

These racks are for establishments which work on long runs, for color work, and for lithographers. They are used on *Puck* and *Truth*, and the American Lithographing Company has over 25,000 of them in its various establishments in New York City alone.

With these racks sheets are taken direct from the fly of the press, and may be stacked ceiling-high in a perfectly straight and rigid pile, which cannot be knocked over by accident, and with no more weight on the bottom than on the top sheets. This pile is a most effective drying room, occupying only the floor space of one rack, and from the time the sheets are fed into the machine until ready for shipment they need not be handled. The interlocking device, which makes the pile straight and rigid, is shown in Figure 2. Each rack is firmly locked on its neighbor, but each slides with ease on the rack immediately below it. They save handling, all the time of that operation, and the consequent waste of paper through offset, smearing, finger-marks and tearing. In many cases these racks save expensive slip-sheeting.

They circumvent electricity by receiving the sheet direct from the fly. They insure evenness of temperature, and thereby assist in getting a perfect register on lithographic work. They save seventy-five per cent. of floor space over any other method of drying sheets, and from one to two per cent. of paper, and a vast amount of time. A further saving of time may be effected by placing the racks as they come from the fly-board on a printer's truck, made specially to take these racks (see next page). A pile of racks can be moved quicker, safer and easier on the truck than a single armful can be moved by hand. The racks have hard-wood sides with wide soft-wood slats, and are very strongly put together.

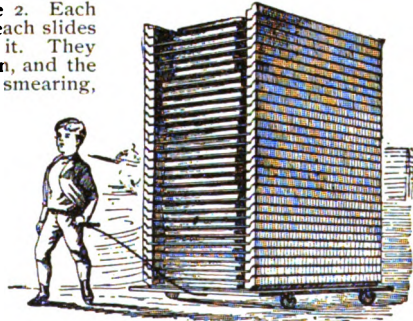

Fig. 1. Köerner's Racks on Printer's Truck.

NET PRICES.—Special Quotations Made on Car-load Lots.

These racks are made to order, and sizes will be varied to suit purchasers, at prices approximate to those quoted here:

38 × 52 in. inside and under \$0 65	15 × 21 in. inside and under . . . \$0 35
32 × 48 in. inside and under 0 60	13 × 19 in. inside and under . . . 0 30
24 × 36 in. inside and under 0 50	11 × 17 in. inside and under . . . 0 25
18 × 25 in. inside and under 0 40	8½ × 13 in. inside and under . . . 0 20

MILLER PERFECT GRIPPER PERFORATOR.



Made of steel, to attach to any platen press. Perforates neatly and cleanly while printing. Does not interfere with impression. There is a half elliptical spring which pushes the perforated sheet off the perforating knife.

For Eighth-Medium Press, net	\$5 00
For Quarter-Medium Press, net	6 00
For Half-Medium Press, net	7 00

When ordering it is necessary to state name and size of press.

PRINTERS' TRUCKS.

Lay Printed Sheets on Trucks and not on the Floor, and thus Save Cost and Loss in Handling.

With platform 34 inches wide by 50 inches long, 11 1/4 inches high \$16 00

Special prices in quantities. Other sizes at proportionate rates.

Made of hard wood 1 1/4 inches thick, bolted, varnished. Center wheels, 9 3/4 inches diameter, 3 inches face. Caster wheels, 4 3/4 inches diameter, 1 1/4 inches face. Steel axle, 1 1/4 inches square, with steel braces 1 1/4 x 1/4 inches. The T-shaped handle is of 3/8-inch round steel, and is quickly attached to or detached from two eyelets fixed at each end. Weight, 182 pounds; handle weighs 11 1/2 pounds.



In 1896 we sold 120 of these trucks on one order to Matthews-Northrup Co., Buffalo, for use in their printing department.

CHANDLER & PRICE GORDON PRESS.

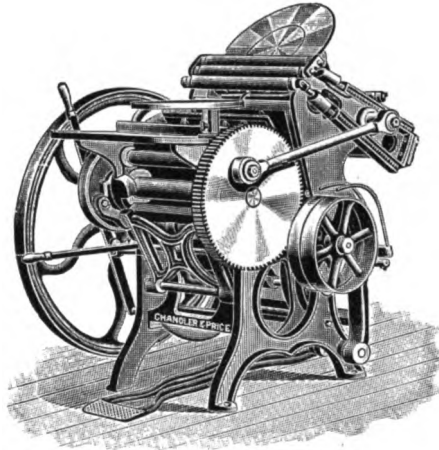

A most popular press, and over 10,000 are in use. They are built to withstand both use and abuse. Side arms and shaft are made of forged steel, without seam or weld. Cam rollers are made of hardened tool steel. Impression throw-off is positive and easy to operate. The grippers are depressible, and cannot get under the rollers. Chase clamp is safe and instantaneous.

Eighth Medium,	7	×11 inches inside chase	\$150 00
Eighth Medium,	8	×12 inches inside chase	165 00
Quarto Medium,	10	×15 inches inside chase	250 00
Half Medium,	12	×18 inches inside chase	300 00
Large Half Medium,	14	×20 inches inside chase	400 00
Half Super-Royal,	14½	×22 inches inside chase	450 00
Steam Fixtures, all sizes		15 00
Buckeye Fountain		10 00
Chandler & Price Fountain		20 00

With each press there are three chases, one brayer, two sets of roller stocks, two wrenches and one roller mould. No charge for boxing and shipping. If desired, will furnish two extra chases instead of mould.

Shipping weights: 7×11, 1000 lbs.; 8×12, 1200 lbs.; 10×15, 1800 lbs.; 12×18, 2500 lbs.; 14×20, 3000 lbs.; 14½×22, 3100 lbs.

For prices of extra chases, see "Chases."

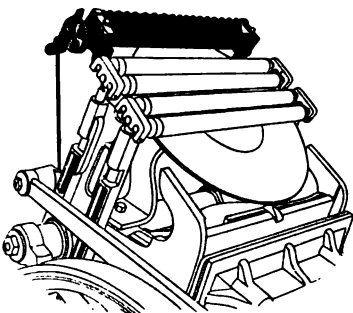

Chandler & Price Fountain.

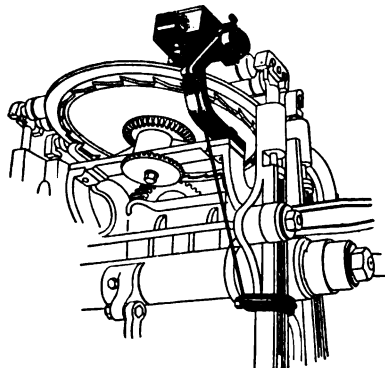

The Buckeye Fountain.

CHALLENGE GORDON PRESS.

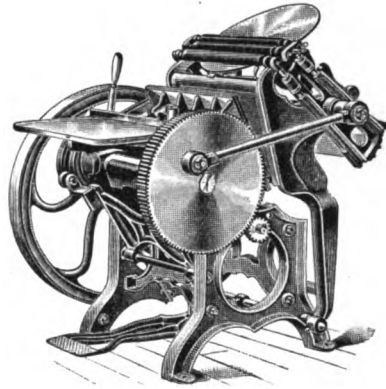

An up-to-date press, well constructed, and with all improvements found on any Gordon press.

7×11 inches inside chase . . .	\$150 00	13 × 19 inches inside chase . .	\$350 00
8×12 inches inside chase . . .	165 00	14 × 20 inches inside chase . .	400 00
9×13 inches inside chase . . .	225 00	14½ × 22 inches inside chase . .	450 00
10×15 inches inside chase . . .	250 00	Power fixtures, all sizes	15 00
12×18 inches inside chase . . .	300 00		

Challenge Pony Fountains—For 7×11, 8×12, and 9×13 presses, \$12; for 10×15 and 12×18 presses, \$13.50; for 13×19, 14×20, and 14½×22 presses, \$15.

Challenge Full-Length Fountains—For 7×11, 8×12, and 9×13 presses, \$25; for 10×15 and 12×18 presses, \$27.50; for 13×19, 14×20, and 14½×22 presses, \$30.

Three chases, wrenches, roller mould, brayer and two sets of roller stocks will be furnished with each press.

**NEW STYLE
FRANKLIN GORDON.**

The latest invention of Mr. George P. Gordon, inventor of the popular Old Style Gordon.

8×12 inches inside chase	\$225 00
9×13 inches inside chase	250 00
10×15 inches inside chase	300 00
11×17 inches inside chase	350 00
13×19 inches inside chase	400 00
Ink fountains, for all sizes	25 00
Steam fixtures, for all sizes	15 00

One roller mould, six roller stocks, three chases, one impression wrench, one gripper wrench, and one hand-roller are included with each press.

The shipping weights when closely boxed are: 8×12 press, 1100 lbs.; 9×13 press, 1150 lbs.; 10×15 press, 1600 lbs.; 11×17 press, 1700 lbs.; 13×19 press, 2100 lbs.

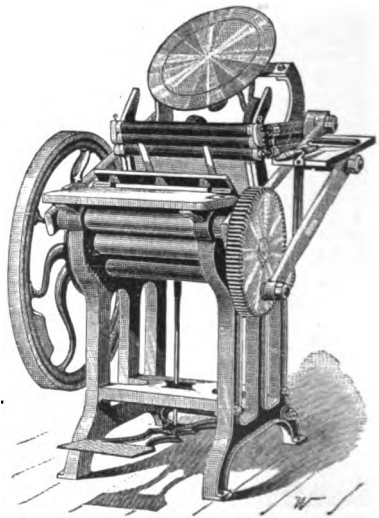

HARRIS AUTOMATIC ENVELOPE AND CARD PRESS.

Fastest Job Press. Speed from 5000 to 12,000 per Hour.

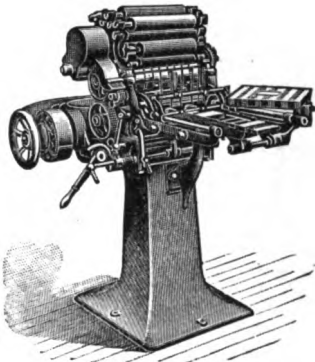

The Harris Automatic is a self-feeding and self-delivering press of recent introduction but well-established reputation. It prints cards and envelopes in one or more colors in first-class style, and will supersede all other presses on work within its capacity in offices where envelopes, cards, or tags, are printed in large quantities in runs of 3000 at a time and upward. It registers closely. It has an automatic throw-off, which causes it to cease taking impressions whenever the grippers fail to grasp the sheet, thus effectively preventing waste of stock as well as offsets. The printing is done from curved stereo. or electro. plates. Making ready is convenient and easy. It is possible to make-ready and run off 5000 envelopes in forty minutes. Distribution is abundant and effective. There is an adjust-

able ink fountain. The capacity is from the smallest envelope corner to plates not exceeding 11x13 inches. Prices, terms, circulars, etc., sent on application.

PEERLESS PRESS.

Of well-established reputation, smooth running, noiseless, easy to make-ready on, easy to feed, easy to run by treadle, with an effective throw-off, well built, exceptionally strong, and with a powerful toggle movement. The throw-off is positive and easy, and convenient to handle. The platen is sustained in the center by the toggle, and is strongest where platens are generally weakest, enabling the Peerless to do embossing and paper-box cutting and creasing, which taxes a press very severely. It is a fast press.

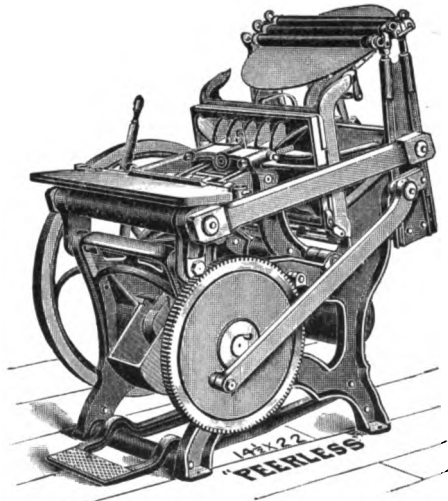

Eighth Medium	8	× 12 inches inside chase	\$225 00
Large Eighth Medium	9	× 13 inches inside chase	250 00
Quarto Medium	10	× 15 inches inside chase	300 00
Large Quarto Medium	11	× 17 inches inside chase	350 00
Half Medium	14	× 20 inches inside chase	450 00
Half Super-Royal	14½	× 22 inches inside chase	500 00
Pony Ink Fountain, all sizes			10 00
Hinged Well Ink Fountain, all sizes			25 00
Power Fixtures on Press, all sizes			15 00

Three chases, six roller stocks, one roller mould, one impression wrench, one brayer, two sets roller trucks, are furnished with each press.

Extra chases cost: For 8x12 press, \$1 50; for 9x13, \$1 50; for 10x15, \$2 00; for 11x17, \$2 00; for 14x20, \$2 75; for 14½x22, \$3 00.

GALLY UNIVERSAL PRESS.

The Gally Universal Press is made in three styles, which are described on next page.

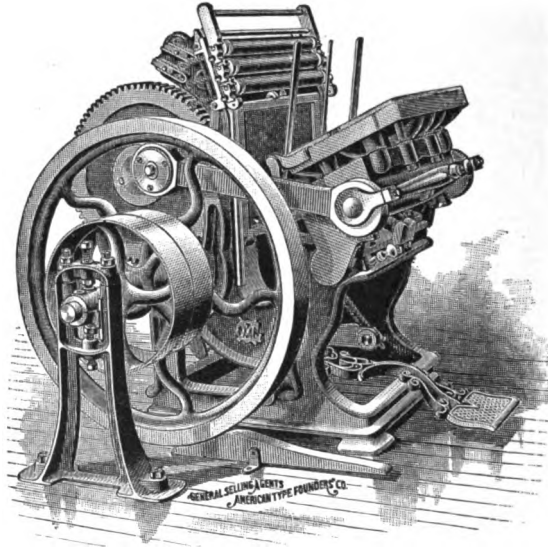

Excels all other types of platen presses because: (1) The bed and frame are cast in one piece, securing rigidity and keeping all shafts in line in spite of irregularities in floor or foundation. (2) The platen moves up squarely against the type form, giving a perfectly square impression. (3) The platen has nine supports, and is extra heavy, and is the only platen capable of sustaining the powerful impression necessary to secure the best results on large forms of cuts. (4) The impression can be thrown off instantly, the throw-off being controlled by a bar directly behind the platen. (5) The impression can be changed instantly all over the platen, varying from the imperceptible to an eighth of an inch. (6) The platen opens out widely, making it easy to feed paper into it. (7) The ink fountain is as efficient as the fountains on the highest grade cylinder presses. It is the most perfect fountain for a platen press ever made. (8) The operations of ink distribution and "inking" the form are distinct, and each performed by a separate set of rollers. In addition to the fountain ductor roller, there are four ink distributors (two of composition, two of iron) which supply two inking cylinders, from which the three form rollers receive a fresh, distributed supply of ink at each impression. On all other types of presses the form rollers have to distribute the crude ink as it leaves the fountain. (9) The form rollers can be held against the inking cylinders for distribution, while getting up color, and need not touch the type form. (10) The ink fountain can be divided by partitions for printing two or more colors at one time. (11) The weight and strength are greater than in any other platen press, as it is designed to do work that cannot be safely attempted on any other type of press.

The Gally Universal is designed for use by the best class of printers. In the hands of competent pressmen the press is the most durable, and will do first-class work in perfect register longer than any other press. We can refer purchasers to presses which have been in constant use for twenty years, doing perfect work to-day, and bidding fair to give the best results for years to come.

The recent application of continuous-motion impression cranks and a new patented platen control have increased the speed on all sizes. Speed requirements vary with the kind of work.

PRICES OF GALLY UNIVERSAL PRESSES.

Complete with ink fountain, power fixtures, combination belt-shifter and brake, f. o. b. factory.

		Style One.	Style Two.	Style Three.
Quarto Medium,	10×15 inches inside chase . . .	\$350 00		\$450 00
Half Medium,	13×19 inches inside chase . . .	450 00	\$500 00	600 00
Half Super-Royal,	14×22 inches inside chase . . .	515 00	575 00	650 00

The following small parts are included with each press: Three chases, one roller mould (for which two chases will be substituted, if preferred), six form roller stocks, four distributor roller stocks, two ductor roller stocks, twelve roller wheels (six large, six small), two iron lateral distributors, two feed tables, one small and one large wrench, one socket wrench, one chase latch wrench, and treadle fixtures. If treadle fixtures are not required, two chases will be sent in lieu of them.

Power fixtures include fixtures on the press only.

Boxing for export: Quarto Medium, \$7 00; Half Medium, \$10 00; Half Super-Royal, \$15 00, net.

DESCRIPTION OF THE THREE STYLES.

STYLE ONE.

This is the style described above.

STYLE TWO.

Differs from Style One in having a double impression latch and a steel segment in the gear at the point that takes the strain of the impression.

STYLE THREE.

This style is recommended to those who want the best press procurable for executing the finest class of cut, solid block and color printing, cold embossing and stamping. This style is also made in combinations and for special work, as described hereafter.

The style No. 3 Universal Press differs from Style No. 1 in the following particulars:

The driving shaft is extended to carry an extra outside floor support. The pulleys are intended to carry a 2½-inch belt on Quarto Medium and a 3¼-inch belt on larger sizes. The fly-wheel on Quarto Medium weighs two hundred pounds, and on the Half Medium and Half Super-Royal three hundred pounds each. The large gear-wheel has a section of best quality of steel welded into its periphery, in which are formed the impression teeth, *i. e.*, those teeth which are in engagement with the driving pinion and transmit the momentum of the fly-wheel to the cranks during the time of the "nip." The main shaft is of steel, with solid reamed bearing through the bed. The crank-pins are crucible steel, hardened and finely finished. The connecting rods are of forged machinery steel, very heavy, and bushed with phosphor-bronze where bearing on crank-pins. The bridge and platen are solid to each other—no pressure whatever being sustained by screws. Has double impression latch.

COMBINATIONS OF STYLE THREE FOR SPECIAL WORK.

COMBINATION B.

For letter-press printing and (in addition to all work that can be done on regular Style Three Press, listed above) book-cover inlaying, and cutting and creasing. This combination is fitted with a movable ½-inch steel platen plate and a movable ½-inch brass platen plate, the latter for use in cutting and creasing.

Quarto Medium,	10×15 inches inside chase, complete	\$450 00
Half Medium,	13×19 inches inside chase, complete	626 00
Half Super-Royal,	14×22 inches inside chase, complete	676 00

COMBINATION C.

For letter-press printing, hot embossing, and printing on wood not exceeding one inch in thickness (in addition to all work that can be done on Combination B). This combination is fitted with a steam blank (½-inch thick) with pipe connections, a movable ½-inch steel die plate on steam blank, a movable ½-inch steel platen plate, a movable ½-inch brass platen plate, a cast-iron platen blank, ¾-inch thick, with tympan clamps attached, and a cast-iron platen plate ½-inch thick.

In ordering Combination C, it is necessary to state the average thickness of embossing dies. It is recommended that dies should not be more than ¼-inch thick.

* Half Medium,	13×19 inches inside chase, complete	\$722 00
* Half Super-Royal,	14×22 inches inside chase, complete	784 00

Price List continued on next page.

PRICES OF GALLY UNIVERSAL PRESSES—Continued.

COMBINATION D.

For letter-press printing, printing on wood (not exceeding one inch in thickness) and cold embossing. This combination is fitted with a 3/4-inch movable platen blank and a 3/4-inch movable steel platen plate. Cutting and creasing can be done on this combination by adding a 3/4-inch brass platen plate, list prices \$10.00 to \$13.00 each.

- * Quarto Medium, 10×15 inches inside chase, complete \$474 00
- * Half Medium, 13×19 inches inside chase, complete 629 00
- * Half Super-Royal, 14×22 inches inside chase, complete 679 00

*** IMPORTANT NOTICE.**

The specifications given for preceding combinations may be varied to accommodate the requirements of purchasers. In ordering variations from above specifications be careful to state exact thickness of plates and blanks required, and fully describe the work to be done on the press ordered. Special combinations for other purposes made to order at prices proportionate to those charged for above combinations.

PRICE LIST OF ATTACHMENTS FOR GALLY UNIVERSAL PRESS.

	10×15 Press.	13×19 Press.	14×22 Press.
Ink fountain	\$20 00	\$25 00	\$25 00
Fountain partitions, each	4 00	4 00	4 00
Power fixtures on press only	10 00	10 00	10 00
Overhead fixtures, complete	25 00	30 00	30 00
Cast-iron chases	2 00	2 25	2 75
Wrought-iron chases	5 50	6 50	7 25
Roller stocks	0 60	0 65	0 75

SPECIAL FEATURES OF THE GALLY UNIVERSAL PRESS.

TWO TYPES OF PLATEN PRESSES.

The Universal Press, when invented and patented in 1869-70, differed radically both in its fundamental principles and labor-saving appliances from any other platen press in use at that time. Since then platen presses everywhere are divided into two recognized types or classes, each taking the name of the original inventor: the "Gordon" type, with its hinged or "clam-shell" movement of bed and platen, as imitated with slight variations under a great variety of names, all distributing ink by means of a disc, and the "Gally Universal" type, with its fixed bed, sliding platen, square impact of impression on the form, solid frame and cylindrical ink distribution.

IMPRESSION.

The ideal impression is given by a Washington Hand Press, and the impression given by the Gally Universal is similar, and is perfect in practice and in theory. No other type of platen press can give a perfectly square impression.

The platen is massive, and is secured to the platen bridge by four controlling screws which pass through the bridge, and is supported at the corners and in the center by five adjustable screw supports, giving nine supports in all. Thus the utmost strength and an unyielding impression is obtained.

The platen movement in relation to the bed is illustrated in Figs. 2 and 3 (sectional drawings from the inside).

Fig. 2 shows the platen open at the feeding position, supported by the rockers (R) on the slideways (s). The movement is controlled by the draw-bars, which connect with a steel shaft (A) passing through the platen bridge. As the draw-bars pull the platen toward the bed it rocks forward until the flattened toes (e) of the rockers rest on the slideways (s), as shown in Fig. 3.

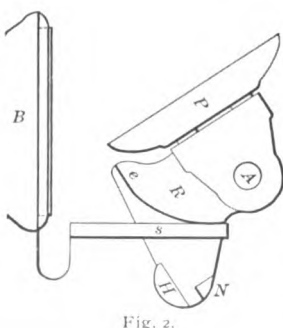

Fig. 2.

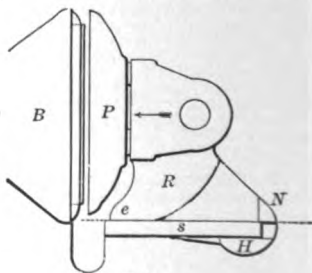

Fig. 3.

The platen is now half an inch from the type form, and exactly parallel to it, and the locking lugs (*N* and *H*) have engaged the slideways at top and bottom, preventing the platen from tipping. Thus secured, the platen slides squarely to the type form, taking a direct face impression. The platen then slides back and rocks to the feeding position again. The curve of the rockers (*R*) are struck from a point at the center of gravity of the whole moving piece, so that the movement is accomplished with a trifling expenditure of effort.

DISTRIBUTION OF INK.

The superiority of the Gally Universal Press is in no point more apparent than in the distribution and application of ink to the form. In Fig. 10 is shown the Gally Universal system of ink distribution. *C* is the main distributing cylinder, and *S* is the secondary distributing cylinder. The composition distributing rollers (*e* and *e'*) revolve on the distributing cylinders, and on top of the distributors are two metallic rollers (*v* and *v'*) with a steady lateral movement in opposite directions, constantly crossing and recrossing the lines of distribution. The ink is supplied from the fountain (*F*, Fig. 10) to the distributing cylinder (*C*), once at each impression, by the ductor roller (*H*), in an evenly spread line, immediately after the form rollers have left the cylinders to ink the form; and before the rollers have completed the rolling of the form and returned to the cylinders the applied ink is thoroughly distributed by the distributors (*e e'*), so that no undistributed ink can ever reach the form rollers or be applied to the form.

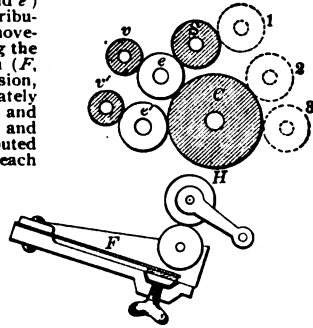

Fig. 10.

The distribution of ink is constant while the press is in motion, whether the form rollers (1, 2, 3) are in contact with cylinder or on the form. The cylinders, rollers and lateral distributors, as shown in Fig. 10, are made of different diameters on uneven measurements, so that their lines of contact are not repeated while revolving.

On presses with disc distribution the form rollers must distribute their own ink and convey it to the form, while on the Gally Universal these two functions are performed by two distinct sets of rollers. In the former case the work is necessarily imperfect; in the latter, both processes give perfect results.

INK FOUNTAIN.

The Gally Universal ink fountain is as complete as the ink fountain of any first-class cylinder press. Every part of it is under positive control. The movement of the fountain cylinder (*R*, Fig. 19) is regulated by a ratchet lever. The ink is carried from the cylinder (*R*) to the distributing cylinder *C*, Fig. 10, by a composition ductor roller. In nearly all ink fountains the regulating screws press directly against the steel blade, and in setting for a fine feed have a tendency to bind the fountain cylinder. In the Universal ink fountain (Fig. 19) *A* is a steel blade, *e* is rubber packing, and *a* is a very thin strip of steel against which the screws (*T*) are set. The rubber (*e*) furnishes an elasticity which prevents the blade from binding, while giving a perfect cut off. With this safeguard a press boy may be trusted to regulate the fountain. The fountain may be removed easily from the press to be cleansed, and is made interchangeable so that an extra fountain for colors may be put on in a few moments.

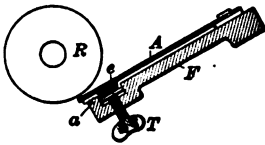
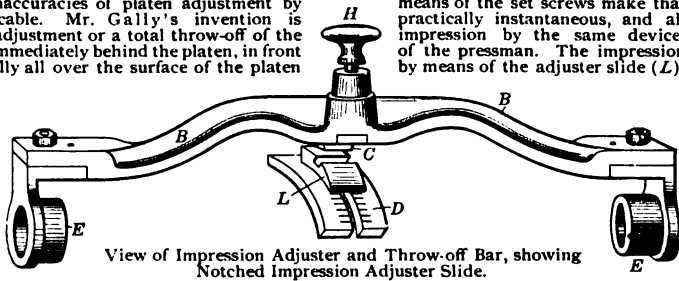

Fig. 19.

ADJUSTMENT OF IMPRESSION AND THROW-OFF.

The Gally Universal Press was the first to have a quick, easy method of adjusting the impression, and the Gally invention is still unexcelled. The theory of modern fine printing calls for a minimum of tympan packing, and to get this a fine adjustment of the platen impression is necessary. The labor means of the set screws make that practically instantaneous, and adjustment by the same device, of the pressman. The impression is regulated equally all over the surface of the platen



View of Impression Adjuster and Throw-off Bar, showing Notched Impression Adjuster Slide.

which can be moved up or down, increasing or decreasing impression from a tissue paper's thickness to 1/4 of an inch. This slide is notched, and the latch (*C*), which is the lower end of the throw-off handle (*H*), engages in this notch. When it is desired to throw off impression, the handle (*H*) is pulled, the latch (*C*) is disengaged, and the adjuster bar (*BB*) drops down, carrying the platen back and preventing it from taking an impression.

GALLY UNIVERSAL EMBOSSEING PRESS.

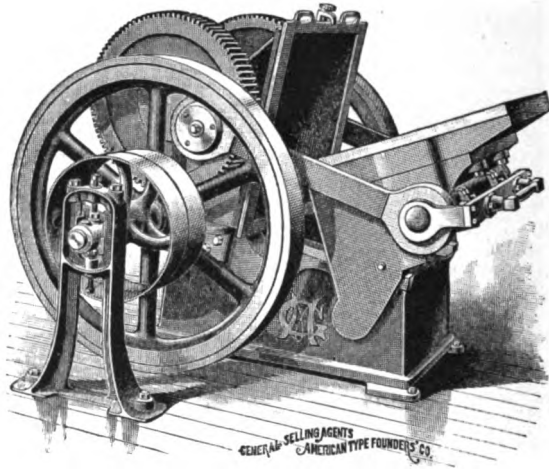

These are the largest embossing presses made, and combine strength, power, speed and facility for handling work easily in a degree unequaled by any other press. They are designed for extra heavy hot or cold process embossing, and book-cover stamping ("smashing"). The mechanical principles employed to give impression, power, and to throw-off impression, are the same as described on pages 900 and 901. Nothing better demonstrates the correctness of the mechanical principles on which Gally Universal Presses are built than their applicability to all degrees of power and strain. Every other type of platen press has its limitations—a point where it gets unwieldy and inefficient.

PRICES OF PRESS ONLY.

No. 1.	21 1/4 x 22-inch bed-plate	\$800 00
No. 2.	24 x 26-inch bed-plate	900 00

PRICES OF EXTRA ATTACHMENTS.

Steam blank, complete, with pipe connections, for No. 1 embosser, with steel die plate	\$105 00
Steam blank, complete, with pipe connections, for No. 2 embosser, with steel die plate	118 00
Steel platen plate for No. 1 embosser	19 50
Steel platen plate for No. 2 embosser	26 00
Cast-iron platen blank for No. 1 embosser	19 50
Cast-iron platen blank for No. 2 embosser	26 00

Each press is complete with power fixtures on press.
 Each press is furnished with three chases (or one cast-iron bed blank in lieu of chases, at option of purchaser), two feed tables, one wrench, one belt-shifter and one brake.
 Gross weight, boxed, of embossing presses are: No. 1, 3,400 pounds; No. 2, 4,300 pounds.
 Boxing for export: No. 1, \$10 00; No. 2, \$15 00, net.
 Prices are f. o. b. factory.

**GALLY UNIVERSAL PAPER-BOX CUTTING AND
CREASING PRESS.**

(See "Paper Box Making" at foot of this page.)

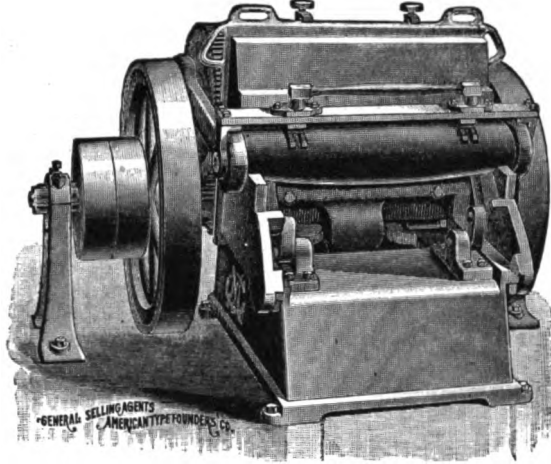

The most satisfactory presses for cutting and creasing paper boxes. Immensely strong, easy to operate, with speed limited only by the capacity of feeder. They will not stall on the heaviest impression. They are built on the same general lines as the Gally Universal Embossing Presses, and have extra steel-gibbed locks on under edge of the platen to prevent deflection of the platen under unequal strain. The platen, which has a throw-off, is set to height of type unless otherwise ordered. Both sizes are double geared.

PRICES.

With Brass Platen Plate and Power Fixtures on Press.

No. 1.	20 × 30 inches inside chase	\$700 00
No. 2.	23¼ × 31 inches inside chase	900 00

Prices are f. o. b. factory.

Each press is furnished with a ½-inch brass platen plate, three chases, two feed tables, one wrench, one belt-shifter and one brake.

Boxing for export: No. 1, \$15 00; No. 2, \$20 00, net.

FOLDING PAPER BOX MAKING.

The process of making folding paper boxes is simple. The stock used is manilla board, made specially for the purpose. A cutting and creasing press is the same as an ordinary printing press, except that it is larger, has to be stronger, and does not require an inking apparatus. The shape of a box having been decided on, a form is set up with steel cutting and brass creasing rules—the former to cut out waste margins and to make slits, and the latter to crease or score the lines on which the stock in the box must bend when set up for use. It is usual to cut and crease as many boxes at one time as can be cut out from a full-sized sheet. The box leaves the press flat. It is then folded once and glued on one edge, and delivered flat. Any printing required is done before cutting and creasing. Any good compositor will understand the process after reading above explanation and examining a folded paper box. The glueing is done by a machine of moderate cost.

THE GOLDING JOBBER.

This press can be bought with or without a number of attachments, such as an automatic brayer fountain, a duplex distributor (which is placed below the bed of the press and furnishes a fresh supply of ink to the form rollers after they have passed downward over the form), a chromatic attachment, and a counter for registering the number of actual impressions, the prices for which are given separately below.

PRICES OF PRESS ONLY.

- No. 6, 8×12 inches inside chase . \$200 00
- No. 7, 10×15 inches inside chase . 275 00
- No. 8, 12×18 inches inside chase . 350 00
- No. 9, 15×21 inches inside chase . 450 00

PRICES OF PRESS, COMPLETE

With Automatic Brayer Fountain, Duplex Distributer and Power Fixtures.

- No. 6, 8×12 inches inside chase . \$245 00
- No. 7, 10×15 inches inside chase . 335 00
- No. 8, 12×18 inches inside chase . 420 00
- No. 9, 15×21 inches inside chase . 520 00

The prices of all Golding Jobbers for letter-press printing include three machine rollers complete, extra set of roller cores, extra set of roller wheels, two chases, ink plate, hand roller, wrench, treadle and brake.

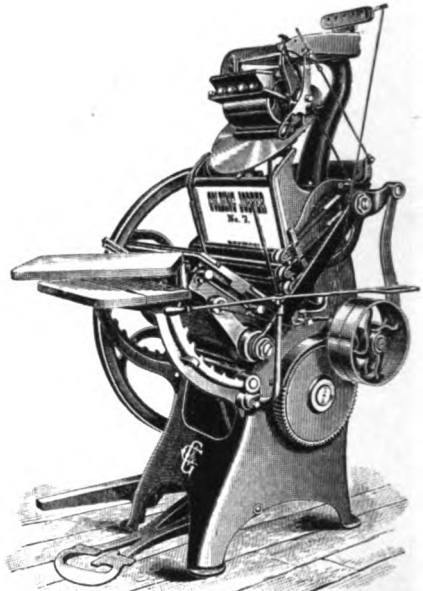

Shows style of Nos. 6, 7 and 8 Golding Jobbers.

PRICES OF ATTACHMENTS AND EXTRAS.

When not ordered complete, any of the attachments or extras wanted will be charged at the following prices:

	No. 6	No. 7	No. 8	No. 9
Fountain and automatic brayer	\$25 00	\$35 00	\$40 00	\$50 00
Duplex distributor	12 00	16 00	20 00	24 00
Chases	1 25	1 50	1 75	2 25
Counter made to attach to press (counts to 10,000)	10 00	10 00	10 00	10 00
Pearl ink fountain	9 00	9 00	9 00	. . .
Power fixtures	14 00	15 00	16 00	17 00
Boxing	4 00	5 00	6 00	8 00

GOLDING ART JOBBER.

This press is built on the same general lines as the Nos. 6, 7 and 8, illustrated above, but is heavier and stronger; has gear-wheel inside the frame; has impression adjustment at back of bed instead of at back of platen; has four form rollers and a duplex distributor (the latter placed immediately under bed, so that ink on rollers is re-distributed before the rollers return over the type form); throw-off by means of an eccentric shaft instead of by wedges; and the automatic brayer fountain covers the full length of the disc instead of half of it. This press is also supplied with the half-length automatic brayer fountain, if desired.

- No. 18 Golding Art Jobber, 12×18 inches, complete, with power fixtures \$500 00
- No. 18 Golding Art Jobber, 12×18 inches, with half-length automatic brayer fountain and power fixtures 470 00

CHROMATIC ATTACHMENT for No. 7 Jobber, including full-length fountain, \$65.00 additional to price of complete press; for No. 18 Art Jobber, having full-length fountain, \$50.00 extra.

PEARL PASSES.

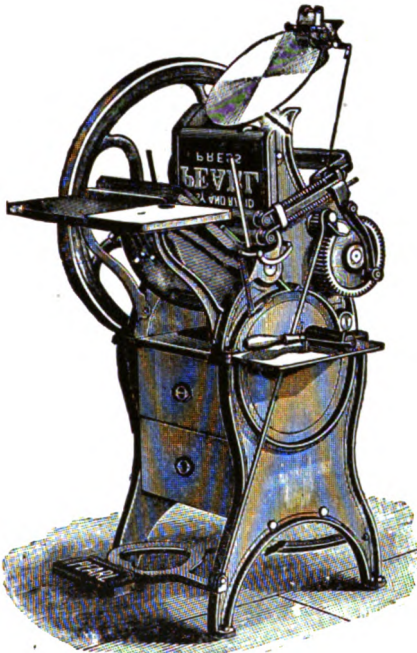

Pearl Presses, Nos. 1, 3 and 5.

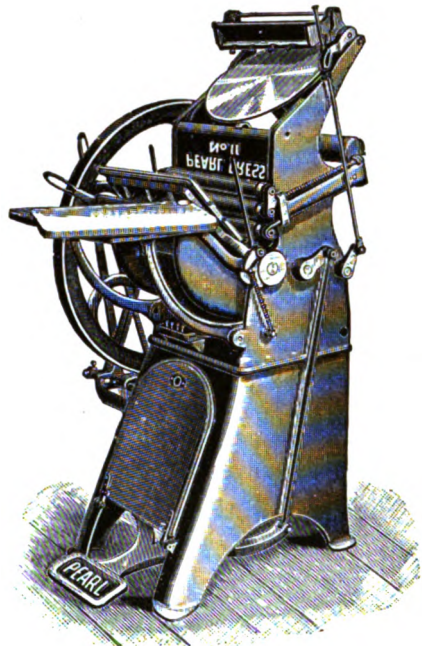

Pearl Presses, Nos. 11 and 14.

Light running presses, without side-arms, very rapid, easy to feed, and handy to make-ready on. They are practically noiseless, easy to keep in repair, and specially desirable in offices that have no power. The No. 1 has three drawers and the No. 3 two drawers in their stands.

PRICES OF PEARL PASSES.

Nos. 1, 3 and 5 have no throw-off. Nos. 1, 3 and 5 have two rollers; Nos. 11 and 14 have three rollers.

No. 1, 5× 8 inches inside chase	\$ 70 00
No. 3, 7× 11 inches inside chase	110 00
No. 5, 9× 14 inches inside chase	165 00
No. 11, 7× 11 inches inside chase	135 00
No. 14, 9× 14 inches inside chase	200 00

The prices of Nos. 11 and 14 include full-length fountain and throw-off.

POWER FIXTURES.

For No. 1	\$ 8 00
For No. 3	9 00
For Nos. 5 and 11	12 00
For No. 14	14 00

PEARL INK FOUNTAINS.

For Nos. 1, 3 and 5 Presses, each \$9 00

A full-length fountain is included in the price with Nos. 11 and 14 Pearl Presses.

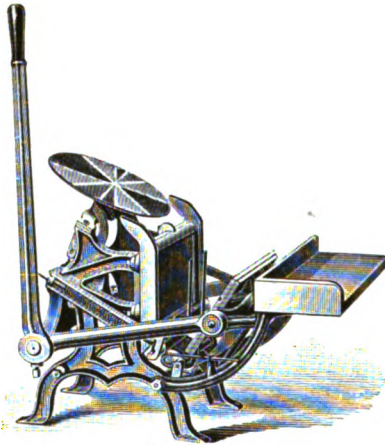

Pilot Press.

PILOT HAND LEVER PRESS.

6½ × 10 inches inside chase \$35 00
Ink fountain 10 00

One chase, one set of covered rollers, and one wrench supplied with each press.

OFFICIAL HAND LEVER PRESSES.

No. 3, 5 × 7½ inches
inside chase . . . \$25 00
No. 4, 6 × 9 inches
inside chase . . . 35 00
No. 6, 8½ × 12½ ins.
inside chase . . . 60 00

One chase, one set of covered rollers, and one wrench supplied with each press.

SECOND-HAND PRESSES.

As a rule, second-hand presses of all makes and sizes can be supplied. Special lists of these are issued at short intervals. Those in want of second-hand machinery are invited to correspond with us. Time will be saved if correspondents will state exactly what they require.

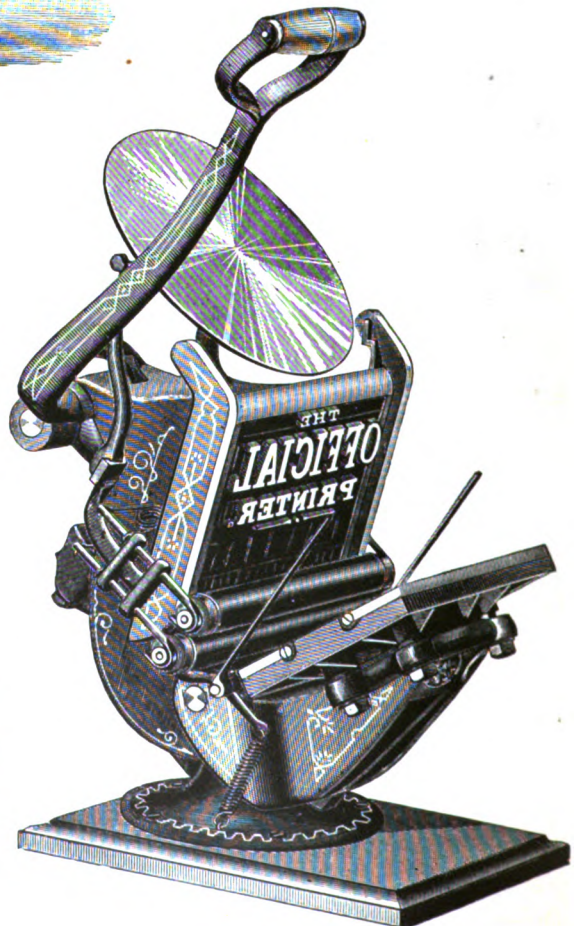

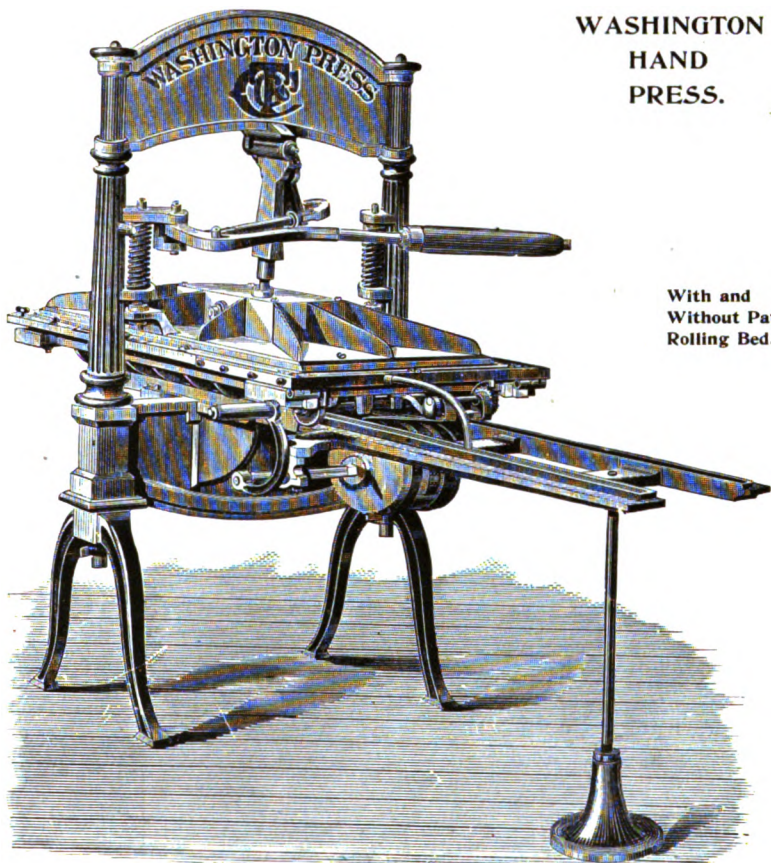

**WASHINGTON
HAND
PRESS.**

With and
Without Patent
Rolling Bed.

Washington Hand Press with Patent Rolling Bed, built solely by American Type Founders Co.

Platen.	Bed.		
14 × 18 inches . . .	17 × 21 inches . . .		\$150 00
16 × 21 inches . . .	20 × 25 inches . . .		175 00
20 × 25 inches . . .	24 × 29 inches . . .		200 00
23 × 31 inches . . .	25 ½ × 34 ½ inches, for 6-column folio . . .		200 00
23 × 35 inches . . .	26 ½ × 39 inches, for 7-column folio . . .		225 00
25 × 39 inches . . .	28 ½ × 42 inches, for 8-column folio or 5-column quarto . . .		250 00
27 × 43 inches . . .	31 ½ × 47 ½ inches, for 9-column folio . . .		275 00

WITH PATENT ROLLING BED.

The Patent Rolling Bed runs on rollers instead of sliding, and thus much exertion is spared the pressman, and the work is done quicker.

Platen.	Bed.		
23 × 35 inches . . .	26 ½ × 39 ½ inches, for 7-column folio . . .		\$250 00
25 × 39 inches . . .	28 ½ × 43 ½ inches, for 8-column folio or 5-column quarto . . .		275 00
27 × 43 inches . . .	31 ½ × 47 ½ inches, for 9-column folio . . .		300 00
29 × 43 inches . . .	33 × 48 inches, for 6-column quarto . . .		325 00

Above prices include two pairs of points, one wrench, one sheepfoot, pair of bearers, and one extra frisket.

As a rule we can supply second-hand Washington Hand Presses of all sizes on demand.

IDEAL HAND CYLINDER PRESS.

The type form on this press is stationary. The cylinder is moved over the tympan by link belts running over sprocket wheels at each end of the press, and it prints a sheet at each forward or backward movement. The cylinder is made of steel, and is held firmly to the tracks by truck-wheels which run in a groove on the under side of the tracks. The boxes which hold the cylinder at each end, and in which it revolves, are connected by a stretcher rod running above the cylinder, which prevents side friction. The impression is regulated by four screws—two on each side—which raise or depress the bearers on which the cylinder runs. An effective inking apparatus is supplied, but is extra. A number of Ideal Presses are in use, and intending purchasers may gather how satisfactory they are to the users by reading the following extracts from a great many commendatory letters received:

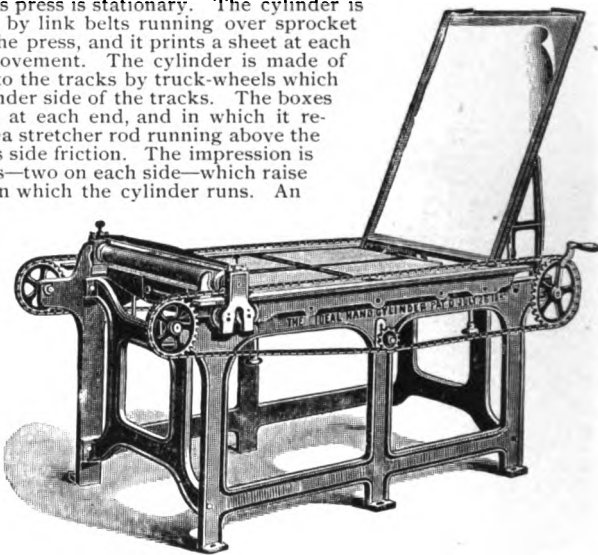

"My wife ran off 300 an hour on it the first day it was put up." *** "With it our inexperienced pressman has made the following speed: 750 impressions in 75 minutes; 475 in one hour; 100 in 11 minutes. We run a regular lick of 100 every 15 minutes, or 400 per hour." *** "We can run an edition in one-half the time and secure a better print than on our Washington." *** "The press is so simple that the veriest novice can set it up, and so light-running that a boy may operate it with ease." *** "It is far superior to my old Washington for speed and quality of work."

- No. 1, 8-column folio or 5-column quarto, size of bed, 28½ × 43 inches \$200 00
 - No. 2, 9-column folio or 6-column quarto, size of bed, 33¾ × 48½ inches 225 00
 - No. 1. Floor space, 31 × 55. Weight, 700 pounds. Shipping weight, 975 pounds.
 - No. 2. Floor space, 35 × 60. Weight, 800 pounds. Shipping weight, 1100 pounds.
- Frisket for No. 1 extra, \$6.00; for No. 2, \$6.50.

IDEAL INKING APPARATUS.

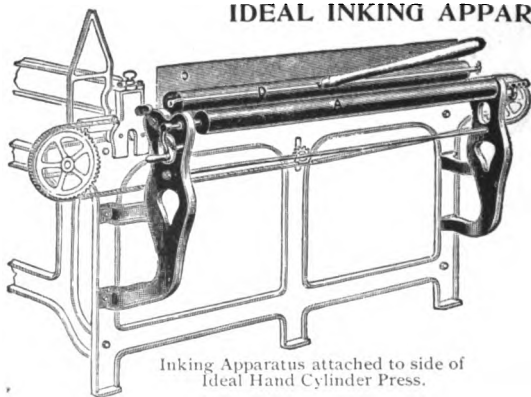

Inking Apparatus attached to side of Ideal Hand Cylinder Press.

There are two inking cylinders (A and B), one of which (A) revolves by means of the hand crank, and while revolving it automatically vibrates. The inking roller (D) rests on the inking cylinders and receives its supply of distributed ink. When the roller (D) is pushed toward the form, the automatic sheet-steel drop-leaf ink table (C) descends on the bed of the press and the roller (D) passes easily on to the type form. When the roller returns, the ink table (C) resumes its perpendicular position automatically. The Ideal Inking Apparatus is not furnished with the Ideal Press unless specially ordered.

- No. 1, for 8-column folio or 5-column quarto . . . \$30 00
- No. 2, for 9-column folio or 6-column quarto . . . 32 00

Hand Roller with Two Handles, Including Extra Core:

- No. 1. 20 inches long, for 8-column single page \$3 75
- No. 2. 22 inches long, for 9-column single page 4 25

CHALLENGE COUNTRY HAND CYLINDER PRESS.

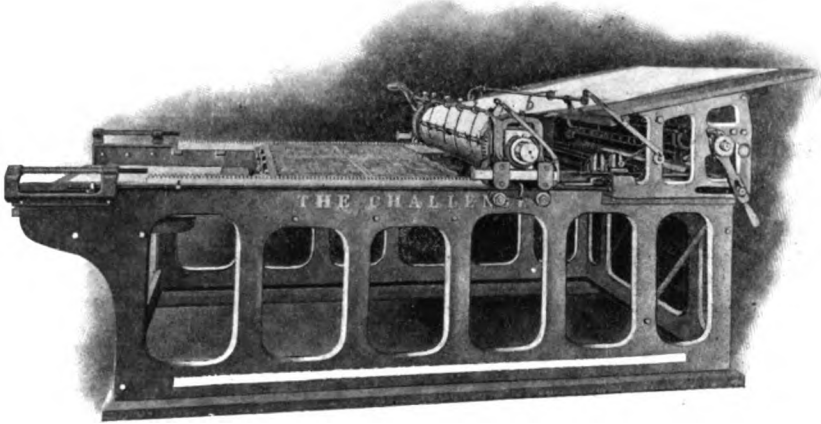

The cut shows the cylinder just as it is taking the sheet, and about to pass over the form. To run it the operator stands on the farther side, about the center of the press, takes the handle with the left-hand, swings the cylinder to make the impression, the right hand carrying it forward to deliver the printed paper and start the cylinder back to receive another sheet. The cylinder travels by means of gears over steel racks, and carries the inking apparatus with it over the stationary type form. The cylinder is lowered automatically just before taking the sheet, and raised when it reaches the delivery end so as to clear the form when returning to the feed-board.

6-column quarto : bed 33×47½ inches ; floor space, 52×106 inches ; weight, boxed, 3500 pounds. Price, f. o. b. Chicago \$500 00

ARMY PRESS.

This is the lowest-priced press on which a news paper of small circulation can be printed. The cylinder is stationary, but adjustable for impression by regulating screws at each end. The bed and form pass under the cylinder, and an impression is taken at each forward and backward movement.

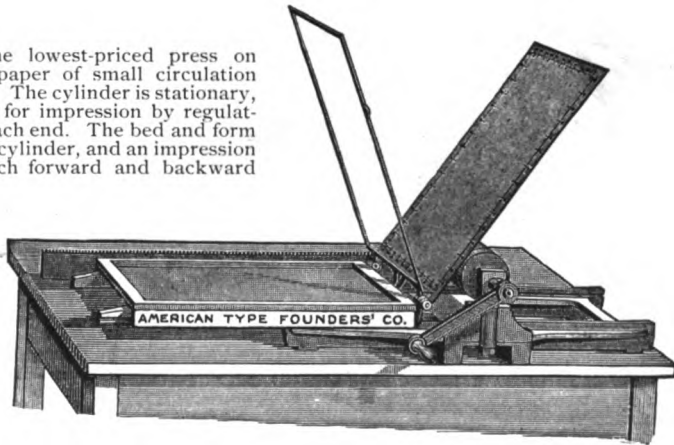

To print one page, 6-column folio, 14 × 20 inches \$ 60 00
 To print one page, 7-column folio, 16¾ × 22¾ inches 85 00
 To print one page, 8-column folio, 19¼ × 25¼ inches 120 00
 To print two pages, 5-column folio, 19¼ × 26 inches 125 00

Two chases, six patent quoins, roller frame and cast roller, oiler and wrench, go with each press.

IMPROVED COUNTRY PROUTY PRESS.

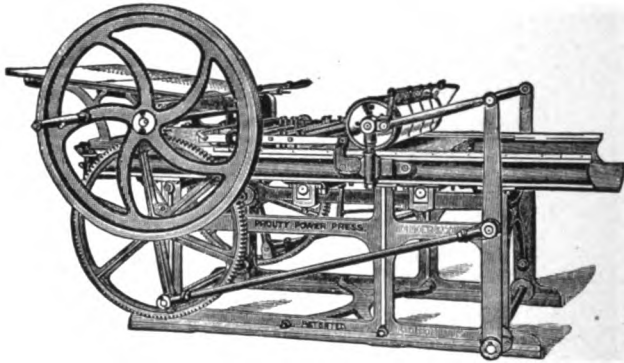

Square sides, patent square drop bed and throw-off. Self-inking. The cylinder rolls over the type form after taking the sheet from the feed-board. The rollers follow the cylinder over the type form. The cylinder is actuated by geared wheels which act on levers connecting at each end of cylinder.

	Size, inside bearers. Inches.	Weight. Pounds.	
No. 1. 7-column folio	27 × 37	3600	\$600 00
No. 2. 8-column folio	27½ × 43½	4000	700 00
No. 3. 6-column quarto	32½ × 46½	4600	800 00

The above prices include well fountain, rubber blanket, set of cast rollers, set of extra cores, and patent throw-off and impression lock. All boxed and on board cars. Steam fixtures, \$15 00 extra.

NEW LEVERLESS MONONA PRESS.

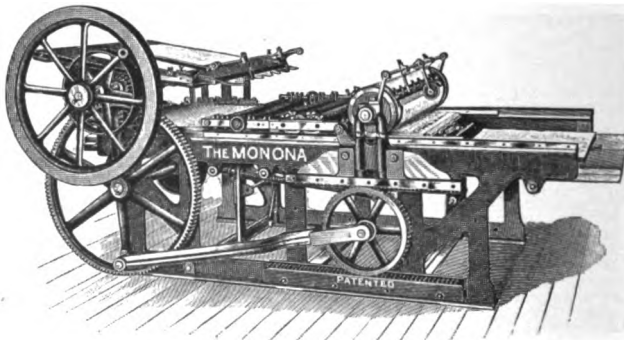

Similar in principle to Improved Country Prouty Press illustrated above, but more substantial in construction and without cylinder levers. The cylinder is held to the rails by a new double spindle cross-head. The cylinder is actuated by geared wheels running in racks.

	Newspaper Press.	Book and Job Press.
7-column folio	\$700 00	\$750 00
8-column folio	800 00	850 00
6-column quarto	900 00	950 00

Each press sold with full set cast rollers, and blanket on cylinder. No charge for boxing. Steam fixtures, extra, \$15 00.

CAMPBELL COUNTRY HAND CYLINDER PRESS.

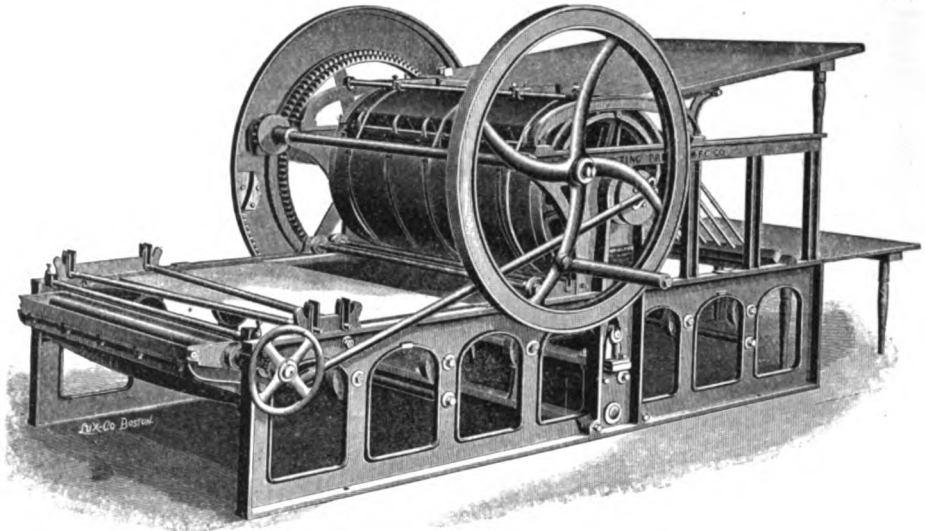

The Campbell Country Hand Cylinder forms a class by itself, and occupies, without a satisfactory rival, the entire field between the Washington hand press and the power cylinder. Thousands are in use, and it has proved a stepping-stone to fortune for a great number of publishers during the past thirty years. It is constructed on the same successful mechanical principles as are used in building the more expensive power cylinder presses, and power fixtures may be added at a small cost. The wear of type on this press is much less than on that class of presses which are constructed on the crude principles of a proof press.

No. 2. Bed, 33×48 inches. Form, 28×44 inches. Standard size for 9-column folio and 6-column quarto	\$800 00
No. 3. Bed, 30×43 inches. Form, 25×39 inches. Standard size for 8-column folio and 5-column quarto	700 00

A rubber blanket, one set composition rollers, extra set stocks, tapes, wrenches, boxing and shipping, are furnished with these presses.

Tight and loose pulleys and belt shifter for power, \$15 00 extra.

TESTIMONIALS SELECTED FROM HUNDREDS EQUALLY FAVORABLE.

J. H. Wilcox, Portsmouth, Va.: "You are mistaken as to my having purchased a Campbell Hand Cylinder Country Press in 1890. I bought one in 1886, and I take great pleasure in saying that it has proved in every way most satisfactory. One small man can turn it continually for hours with ease. It does not get out of order except through negligence, and it is very simple in its operation. This press, I believe, is about sixteen years old, if not older, and it will probably last another sixteen years, if not longer."

Theo. P. Wilson, Winchester, Mass.: "The Campbell Hand Cylinder Country Press purchased from you in August, 1889, has given the utmost satisfaction during its over two years of constant service. I have not spent a cent for repairs, and consider it as good as when first set up. The press is now run by water power, and can print 900 papers per hour. The *Star* I consider one of the cleanest printed papers in this section."

Paragraph Publishing Co., Mamaroneck, N. Y.: "We take great pleasure in saying that the Campbell Hand Cylinder Press purchased of you in September, 1890, has proved in every respect a first-class machine. Although intended to be run by hand, we have been running our press by power for the last three months at an average speed of 840 to 900 per hour. As the press has no springs, we consider this a performance with which we are pleased, and of which you have reason to be proud."

T. H. Harter, Middleburgh, Pa.: "I have been using a Campbell Press for four years, and take pleasure in recommending it to the trade. For simplicity, durability and ease on type it cannot be excelled. My issue of 1600 (6-column quarto) is turned off in two and a half hours, including all stops, and the press hasn't been out of order since I had it, with the exception of the fly-spring breaking. I would not trade it with any press on the market for a country office."

COTTRELL TRIUMPH COUNTRY PRESS.

With Patent Air Springs.

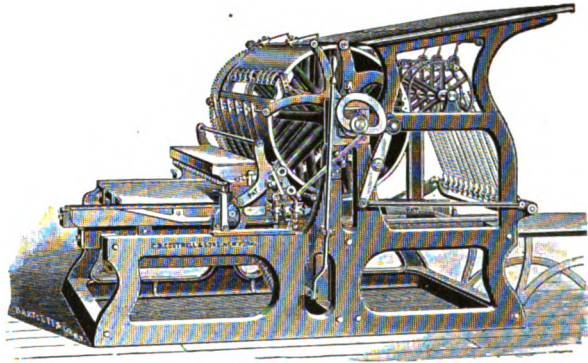

Adapted for printing newspapers, pamphlets, posters, circulars, and all classes of commercial printing. Conforms in construction, design, durability and finish to the high reputation of the manufacturers.

The press is supplied with patent air springs, the resistance of which is increased or decreased according to the speed of the press. It is well known that the faster the speed the greater strength of spring is required. The patent air spring covers these requirements. If the press is running at five hundred per hour, the spring can be easily regulated for that speed; and if running at fifteen hundred per hour, the proportionate increase of spring can be obtained, and so up to the highest speed of which this press is capable. The air spring is provided with an automatic throw-off that releases the pressure when the press is stopped, and the pressman can move the bed to and fro without compressing the spring. When the press is started, the spring is applied automatically.

The patent hinged roller-frame permits of the rollers being instantly uncovered for removal or for other purposes without unscrewing the sockets. The rollers can be taken out and put back without changing their set. The well-fountain is used, being easily regulated and cleansed, and it is set high, giving easy access to the form. The distribution is ample—two three-inch rollers covering the full form. The bed has four supports while under impression, thus securing a clear, even impression. The shoes, tracks and rollers are of hard steel. The gearing is accurately cut, which, together with the registering rack and segment, insures perfect register.

The Triumph Press is built with table, rack and cam distribution, or with the rack and cam distribution, as per illustration on this page.

The Triumph Press can be fitted to run by hand power, when so desired. Tapeless delivery furnished, when required, at an extra charge.

Sizes and List Prices with Rack and Cam Distribution.

	Size of bed inside bearers.	Size of form covered by rollers.	List Price.
No. 3	26 x 37 inches	22 x 33 inches	\$1000 00
No. 5	33 x 47 inches	28 x 43 inches	1100 00

Steam fixtures, extra, \$50 00. Tapeless delivery, extra, \$75 00. Table, rack and cam distribution, extra, \$75 00.
Price includes rubber blanket, wrenches, two sets of roller stocks, roller moulds, boxing and shipping.

COTTRELL MONARCH TWO-ROLLER PRESS.

With Two Rollers Covering Form.

**Air Springs.
Tapeless Delivery.**

**Back-Up Movement.
Hinged Roller-Frame.**

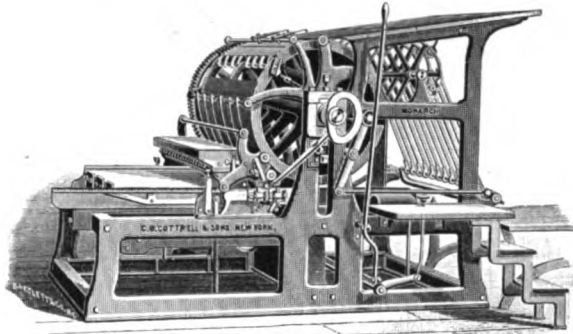

It has many advantages and improvements, including patent air springs, patent tapeless delivery, back-up movement, hinged roller-frame, and iron steps and feeder's stand, and in its manufacture quality is placed first and cost afterward.

It is a press of excellent design, of the best materials, and of high speed. By manufacturing them in large quantities, and building but two sizes, the price is put within the reach of the printer of moderate means.

It is a fast press—1600 per hour is easily possible on the larger and 2000 on the smaller size.

It has four bearings under the bed for extreme rigidity and strength, and steel tracks and steel rollers. There is a heavy flange on the ends of the cylinder as an added element of strength.

The patent air spring forms an easy cushion for the bed in passing the centers, is under perfect control, and can be readily adjusted for the different speeds. The air spring has a new automatic throw-off, so that in turning over the centers by hand the spring is not compressed.

The patent back-up movement is a great convenience and a labor-saver.

The patent hinged roller-frame permits the form rollers to be instantly uncovered for removal or other purposes without unscrewing the sockets. The rollers can be taken out and put back without changing their set.

The well fountain is used, being easily regulated and cleaned. It is set high, giving easy access to the form.

Furnished with table and rack and cam distribution at an extra charge, or only with rack and cam distribution as illustrated.

Sizes and List Prices, with Rack and Cam Distribution.

Size of bed inside of bearers.	Size of form covered by two rollers.	List Price.
No. 3, 26 x 37 inches	22 x 33 inches	\$1500 00
No. 5, 33 x 47 inches	28 x 43 inches	1800 00

Table distribution. **\$75 00** extra.

Price includes hard-packing or rubber blanket, wrenches, two sets of composition roller stocks, roller moulds, countershaft, two hangers, two four-speed cone pulleys and driving pulley, boxing and shipping.

COTTRELL PARAGON JOB AND NEWSPAPER PRESS.

With Two Rollers Covering a Full Form.

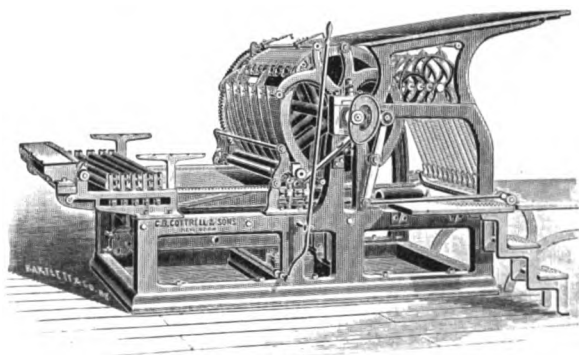

The side frames rest upon and are fastened to a substantial bed-plate, thus insuring stiffness and rigidity of construction. The side frames are changed in design, the flanges projecting inward, and are massive in appearance.

The girt is cast solid with the bed-plate, and carries a pair of substantial rollers adjustable in their box bearings. These rollers operate in connection with extra steel tracks beneath the bed, which, with the ordinary ribs, sliders and tracks, form four separate bearings directly beneath the "impression," making any spring in the bed an impossibility.

The patent air spring, as applied to the press, forms an easy cushion for the bed in passing the centers, and can be readily adjusted for the different speeds.

In connection with the air spring is an automatic throw-off, which permits of the press being turned by hand without compressing the spring. This device is entirely automatic, and does not require any attention.

These presses are supplied with the well-fountain, placed high above the bed, to admit of easy access to the form. The roller frames are hinged in such a manner as to enable the pressman to open them in an instant, leaving the form rollers free for removal. The roller bearings are made adjustable in every direction.

The sheet delivery is tapeless, and fingers of the fly are adjustable transversely to suit position of delivery wheels and nature of sheet to be delivered. The ends of the cylinder are flanged to increase its rigidity.

The Paragon Press is supplied with table, rack and cam distribution, as illustrated on this page, at an extra charge, or with rack and cam distribution.

Sizes and List Prices, with Rack and Cam Distribution.

	Size of bed inside bearers.	Size of form covered by two rollers.	List Price.
No. 5	33 x 47 inches	29 x 43 inches	\$1900 00
No. 6	33 x 50 inches	29 x 46 inches	2000 00
No. 7 } Flange Frames	34 x 52 inches	31 x 49 inches	2200 00
No. 8 }	37 x 54 inches	34 x 51 inches	2500 00

Table distribution, \$75 00 extra.

Price includes hard-packing or rubber blanket, wrenches, two sets of composition roller stocks, roller moulds, countershaft, two hangers, two four-speed cone pulleys and driving pulley, boxing and shipping.

THE CRANSTON PRESSES.

These presses have always been built on high-grade lines. The motto of the maker, painted conspicuously in the factory, "First learn to do a thing well, then learn to do it quickly," has been consistently carried out, and it can safely be affirmed that the Cranston presses are unexcelled in fine workmanship, true mechanical principles, and superior materials, all which result in durability, smoothness, and general satisfaction. The new series of 1897 have numerous up-to-date improvements, and some sizes have been changed for the better convenience of printers. The numerous users of Cranston presses will be more than pleased with the new series.

THE CRANSTON NEWSPAPER PRESS.

**Two-Roller,
With Rack and Pinion Distribution.**

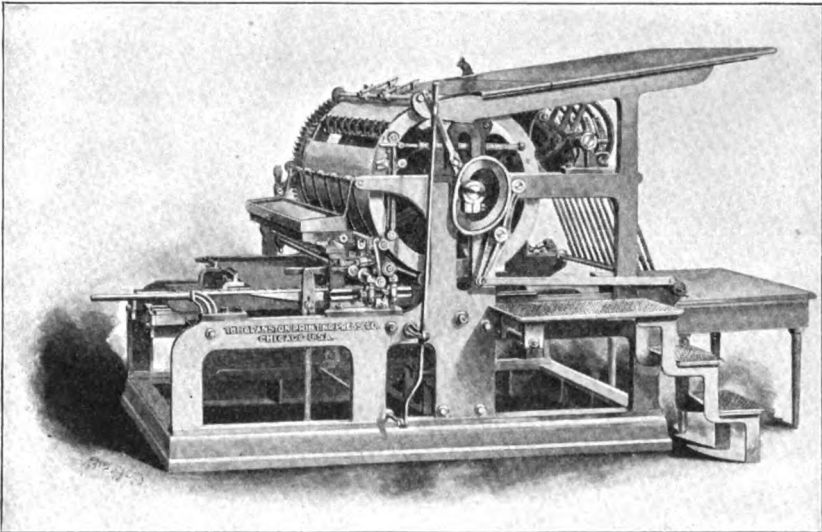

Built of the best material ; furnished at a moderate price ; put to practical tests ;—it has proved by constant use to be an economical press to buy. The runners on both track and table are steel ; the shafts, rolls, studs, shoes and wearing parts are also steel. All gears and racks are cut from the solid. The press is provided with air springs, tapeless delivery, noiseless gripper motion, continuous fly cam, adjustable feed guides. The fountain is placed high on the stand, thus giving easy access to bed of press. The form rolls are made of wrought iron pipe, and are of large size, easily placed in position and adjusted. There is a brake, a fountain cover, reel rod for blanket and tympan, and a guard for distributing rack. Distribution is controlled by cam movements.

Size.	Inside Bearers.	Matter Covered.	Length of Base.	Width of Base.	Weight Boxed.	Price.
No. 3½ . . .	33×48 . . .	28×44 . . .	7 ft. 7½ in. . . .	5 ft. 3½ in. . . .	900 lbs. . .	\$1600 00

An additional charge for table distribution.

Each press is furnished with overhead fixtures complete (except when furnished with hand power only), blanket, wrenches and one set stocks, also one extra set stocks and iron steps.

THE CRANSTON IMPROVED NEWSPAPER PRESS.

Two-Roller, with Rack and Pinion Distribution.

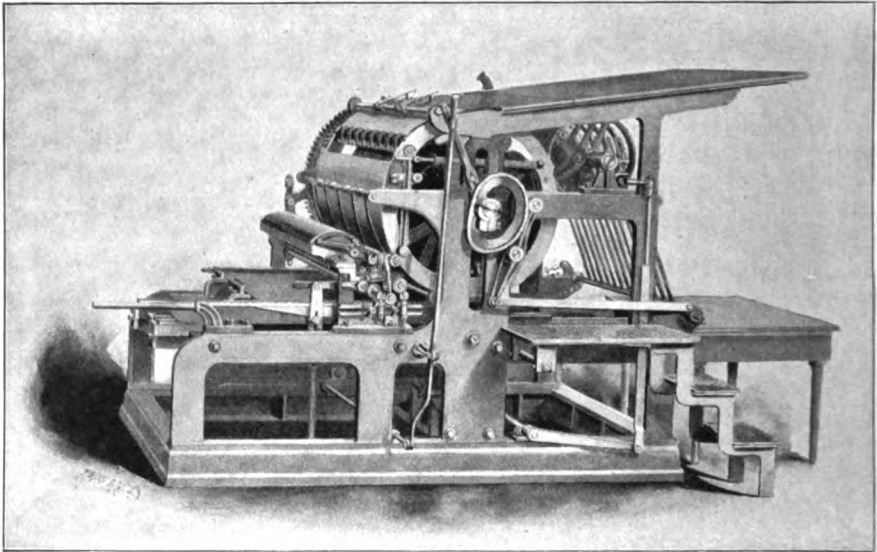

The Improved Newspaper Press has been materially changed in construction and general appearance. All racks and gears have wide faces, and are cut from the solid. The press has air springs; tapeless delivery—wheels adjustable to any size sheet; patented device for controlling motion of sliders; patent stop and reversing motion; noiseless gripper motion; continuous fly cam; feed guides that are capable of the finest adjustment; large size form rollers; long register rack and segment; deep fountain; cover for fountain; convenient arrangement for adjusting fountain roll; cylinder distribution.

Every convenient feature that the price at which it is offered will permit is put on this press, effecting a saving of time and labor for which the Cranston presses are well and favorably known.

Size.	Inside Bearers.	Matter Covered.	Length of Base.	Width of Base.	Weight Boxed.	Price.
No. 3½	33 × 48	28 × 44	7 ft. 7½ in.	5 ft. 3½ in.	9500 lbs.	\$1800 00
Table distribution extra.						

Each press is furnished with overhead fixtures complete, blanket or hard packing, wrenches, iron steps, two complete sets stocks—one set cast with composition ready for immediate use.

THE CRANSTON IMPROVED BOOK AND NEWSPAPER PRESS.

Two-Roller, with Rack and Pinion Distribution.

The Improved Book and Newspaper Press has all of the features which made the Improved Newspaper Press the best newspaper press in the market, and in addition has a separate heavy cast-iron base plate which gives additional strength and solidity to the machine, and makes it possible to run it at a higher rate of speed without jar or injury to the press. It is especially designed for fine book, newspaper and general job printing. For accuracy of register and convenience of making ready, it is unexcelled. The workmanship and wearing qualities are unsurpassed.

Size.	Inside Bearers.	Matter Covered.	Length of Base.	Width of Base.	Weight Boxed.	Price.
No. 3½	33 × 48	28 × 44	7 ft. 7½ in.	5 ft. 3½ in.	10,000 lbs.	\$2200 00
Table distribution, extra 100 00						

Each press is furnished with overhead fixtures complete, blanket or hard packing, wrenches, iron steps, two complete sets stocks—one set cast with composition ready for immediate use.

THE CRANSTON PATENT IMPROVED TWO-ROLLER PRINTING PRESS.

For Fine Book, Commercial and Newspaper Printing.

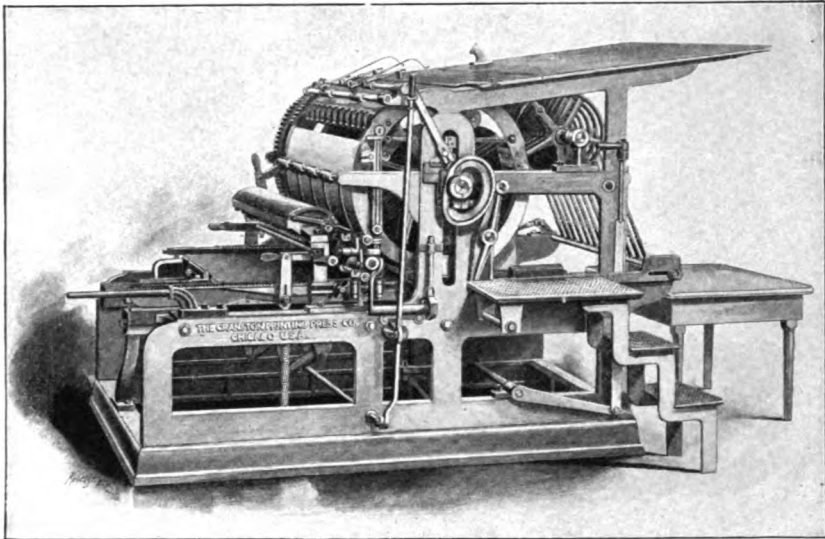

This press is carefully made in every detail. The stock and finish are unexcelled. The tracks are wide, and provided with steel rolls and runners. The wearing parts—shafts, knuckles, shoes, studs—are of steel. The gears and racks are cut from the solid, and have wide faces. The press has air springs; patent silent slider motion, which insures uniform travel of the sliders with the table; patent stop and reversing motion; improved feed guides; patent adjustable side-guide leaf on feed table, which can be set for the greatest precision of register.

The fly is operated by a silent motion, the cam having a continuous surface.

The fountain basin is deep, and will carry a large supply of ink. It is placed high on the stands, and easy access is thus given to the bed of the press.

The Cranston combines the essential features: great strength, unyielding impression, fine distribution, exact register, with convenience in adjustments and make-ready. It is operated with light power, and cannot but give satisfaction both in quantity and quality of work produced.

Size.	Inside Bearers.	Matter Covered.	Length of Base.	Width of Base.	Weight Boxed.	Price.
*No. 0	18 · 25	13 · 21	5 ft. 4 in.	3 ft. 3¼ in.	4,500	—
*No. 1	21 · 28	16 · 24	5 ft. 8¾ in.	3 ft. 8¾ in.	5,500	—
*No. 1½	21 · 36	16 · 32	5 ft. 8¾ in.	4 ft. 4½ in.	6,500	—
*No. 1A	24 · 30	19 · 26	6 ft. 2½ in.	3 ft. 10½ in.	6,500	—
No. 2	25 · 36	22 · 32	6 ft. 5½ in.	4 ft. 6 in.	7,500	—
No. 2A	25 · 38	22 · 34	6 ft. 8¾ in.	4 ft. 7¾ in.	8,500	—
No. 2½	29 · 43	24 · 39	7 ft. 4½ in.	5 ft. —	10,000	—
No. 3	32 · 46	27 · 42	7 ft. 9¾ in.	5 ft. 4½ in.	10,500	—
No. 3½	33 · 48	27 · 44	7 ft. 9¾ in.	5 ft. 5 in.	11,000	—
No. 4	34 · 50	29 · 46	8 ft. 4 in.	5 ft. 9¾ in.	13,000	—
No. 5	36 · 52	31 · 48	8 ft. 8½ in.	5 ft. 9½ in.	13,500	—
No. 5½	38 · 54	33 · 50	9 ft. —	5 ft. 11½ in.	14,000	—

* Commercial Series.

Each press is furnished with overhead fixtures complete, blanket and hard packing, wrenches, iron steps, and two complete sets stocks.

THE CRANSTON-VICTOR TWO-REVOLUTION PRESS. Two-Roller.

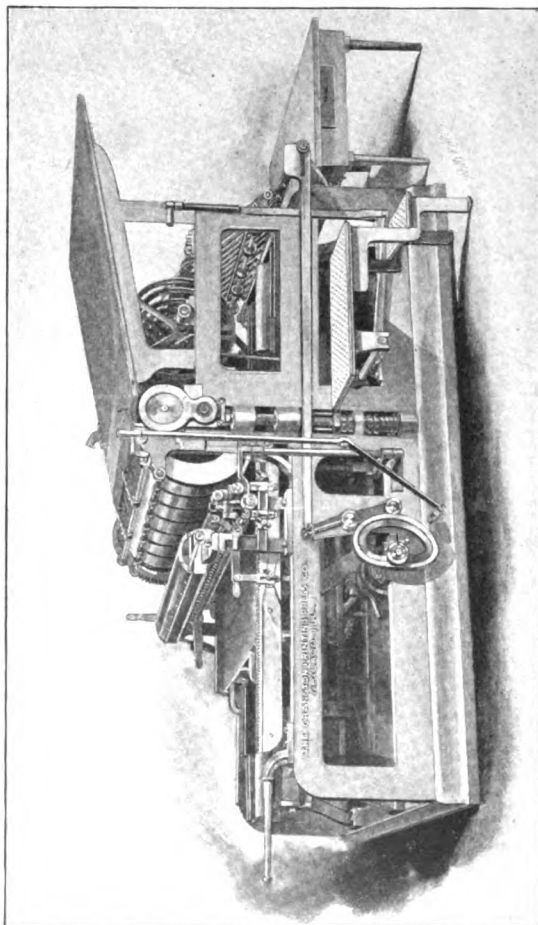

The track has wide runners, laid with steel. The table has three supports—two in the track, one on a center bearing placed on the girt—thus giving three continuous bearings through the line of impression without interference of a third track. Cylinder and lifting shafts, rolls, shoes, knuckles, are of steel. The smaller parts are built with a view to the greatest possible wear.

The mechanism for lifting the cylinder is simple, effective, and controlled by cam movements. No strain and no wear. Steel bearings.

The press has air springs; patent device for controlling motion of sliders; all gears and racks have wide faces, and are cut from the solid; distribution unailing; large size form rollers, with bearings convenient and secure, easily placed in position and as easily removed; fly cam with continuous surface; deep fountain basin; arrangement for adjusting fountain roll; cover for fountain; adjustable bearers; hard-wood feed table; patent improved feed

guides and side-guide leaf on feed table; patent stop and reversing motion; automatic leaf-lifting device for preventing the tongues or guides from catching and tearing the tympan while reversing press; arrangement for throwing reel wheels on or off while making ready. The movements are all conveniently and easily adjusted, and positive in their action.

The speed of this press is all that can be obtained from any press of corresponding size and style.

Size.	Inside Bearers.	Matter Covered.	Length of Base.	Width of Base.	Weight, Boxed.	Price.
No. 4	34 × 50 inches	30 × 46 inches	8 feet 6 inches	5 feet 7½ inches	14,500 lbs.	—
No. 5½	38 × 54 inches	34 × 50 inches	9 feet 6 inches	5 feet 11½ inches	16,000 lbs.	—
No. 6	42 × 66 inches	37 × 56 inches	10 feet	6 feet 3 inches	17,500 lbs.	—

Each press is furnished with overhead fixtures complete, blanket or hard packing, wrenches, iron steps, two complete sets stocks—one set cast with composition ready for immediate use.

THE CRANSTON-VICTOR COMMERCIAL PRESS.

Two-Revolution, with Four Rollers.

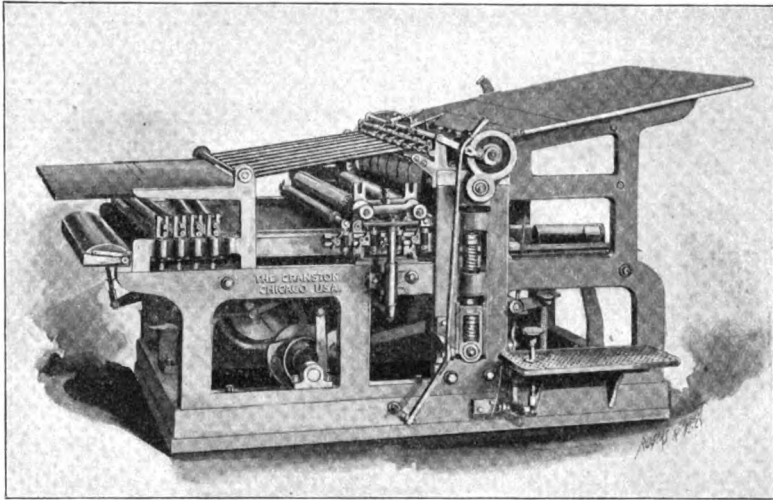

Various methods of engraving having been developed, and their utility practically demonstrated, the demand has been created for a press that will bring out delicate lines of half-tone, process, etched, photo-engraved plates, and work of this description, giving that clear and distinct impression without which the best results are not attainable from such plates. The new Victor Two-Revolution Four-Roller Commercial Press is especially designed for this class of work. Possessing as it does the patented features of our larger sizes, it is, like them, solidly constructed, giving an *unyielding impression* and an *ample inking surface*. Its size is convenient and sufficiently large to meet all demands for work of this class, while the speed provides for rapid production. Many features are embodied in this press for convenience in make-ready, etc. The distribution is a complete system, by means of which every particle of inking surface is *evenly and thoroughly* covered. The movements are easily adjusted and positive in their action. The cam has a continuous surface, and the sheets are laid lightly on the table without smut or off-set. Adjustable fly-fingers. The height of the press is such that it can be fed from the floor, and it is built with special reference to convenience in working about it. Its register is *faultless*. This press is the result of careful study, and embodies suggestions from practical printers regarding the requirements for printing this special work. The very satisfactory results obtained from those in use prove conclusively that the Victor will meet all requirements made upon it.

The speed is equal to all reasonable demands for fine printing.

Size.	Inside Bearers.	Matter Covered.	Length of Base.	Width of Base.	Weight Boxed.	Price.
No. 2A . . .	25×38 in. . .	22×34 in. . .	6 ft. 5¼ in. . .	4 ft. 5¼ in. . .	750 lbs. . .	_____

Each press is furnished with overhead fixtures complete, blanket or hard packing, wrenches, two complete sets stocks.

A WISE PURCHASE.

The No. 2A Cranston-Victor Press is a money-maker. Fine job printing, from small circulars to any size within its capacity, can be done at high speed and with the finest results. In a printing establishment doing general work of all grades this press will prove exceedingly useful and profitable. Its construction and features are such that making ready can be done quickly. It takes in a great range of work which cannot be so profitably printed on a larger press.

THE CRANSTON-VICTOR TWO-REVOLUTION PRESS.

Four-Roller.

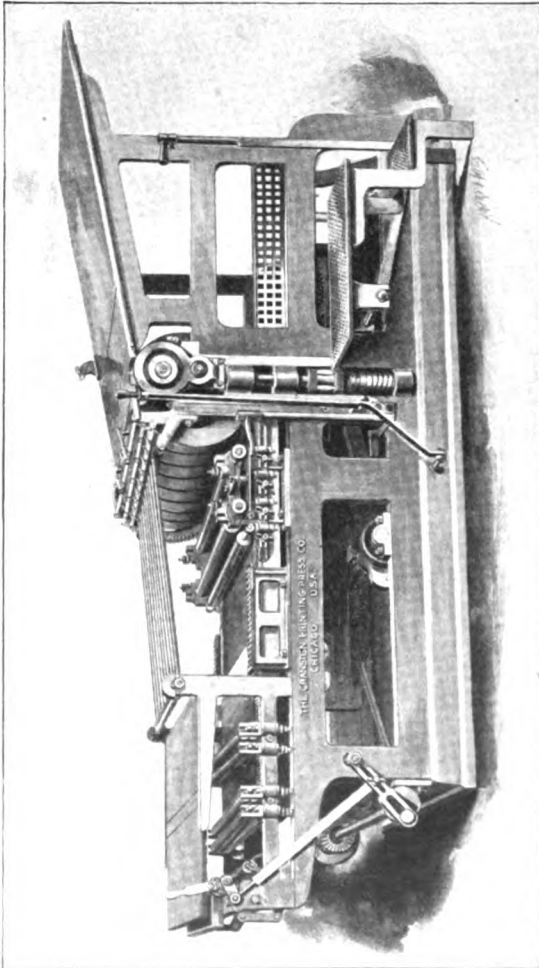

The entire frame of the press is solid and compact. The tracks on both the table and runners are wide, laid with steel, and the rolls traversing on them are of the same material accurately gauged to size. The lifting mechanism for the cylinder is a direct cam motion, plain in construction, smooth running, operated with light power, requiring no weight. The shafts, cams, knuckles, studs, rolls, shoes, and all wearing parts, are of steel, and built with view of greatest possible resistance to wear. The shoes are securely fastened and doweled to the rack hangers. The cylinder has heavy flanges. The impression surface is strongly braced and supported. The press has hard-wood feed table; fly cam with continuous surface. Ample provision is made securing distribution and register. This is a press that can be easily handled, with movements plain and direct in action, adjustments readily and conveniently made, resulting in the greatest economy of time and labor.

This press is provided with a trip, which may be thrown on or off at any point of the stroke of bed. The reciprocating motion of the table is controlled by air springs which are simple and effective, having a plain valve which is in itself direct acting without any complicated attachments. The sheets are delivered to the fly by the tape-delivery on all our presses, the adjustments are made with thumb nuts. The sliders are attached to the table by our patent slider motion, and uniformity in travel is thereby insured. The patent feed guides and adjustable side-guide leaf on feed table can be adjusted with the utmost precision without leaving the feeder's platform. Reel wheels are readily thrown on or off while making ready. The patent stop and reversing motion enables the feeder to stop the press instantly at any desired point, and run it backward, thereby effecting economy of time and labor, as he has absolute control of the press without leaving his position. The automatic leaf-lifting device prevents the tongues or guides from catching or tearing the tympan while reversing press.

less delivery. The down-delivery attachment gives a positive and unailing delivery of sheets on the fly table. As far as practicable on all our presses, the adjustments are made with thumb nuts. The sliders are attached to the table by our patent slider motion, and uniformity in travel is thereby insured. The patent feed guides and adjustable side-guide leaf on feed table can be adjusted with the utmost precision without leaving the feeder's platform. Reel wheels are readily thrown on or off while making ready. The patent stop and reversing motion enables the feeder to stop the press instantly at any desired point, and run it backward, thereby effecting economy of time and labor, as he has absolute control of the press without leaving his position. The automatic leaf-lifting device prevents the tongues or guides from catching or tearing the tympan while reversing press.

Size.	Inside Bearers.	Matter Covered.	Length of Base.	Width of Base.	Weight Boxed.	Price.
No. 4	34 - 50 inches	29 - 46 inches	9 feet 6 1/4 inches	5 feet 7 1/2 inches	17,500 lbs.	
No. 5 1/2	38 - 54 inches	34 - 50 inches	9 feet 6 1/4 inches	5 feet 11 1/2 inches	18,500 lbs.	
No. 6	42 - 60 inches	37 - 56 inches	10 feet	6 feet 3 inches	19,500 lbs.	

Each press is furnished with overhead fixtures complete, blanket or hard packing, wrenches, iron steps, two complete sets stocks—one set cast with composition ready for immediate use.

COMBINATION PAPER JOGGER.

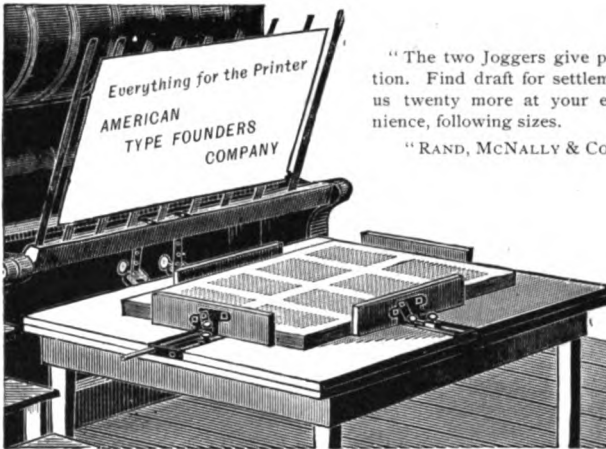

"The two Joggers give perfect satisfaction. Find draft for settlement, and send us twenty more at your earliest convenience, following sizes.
 "RAND, McNALLY & Co., Chicago."

Made with wings, to be instantly removed if desired. No projecting rod on front side to tear clothes. This of itself is worth the price of a Jogger. Patent attachable wings for small Joggers, by which letter-heads, etc., can be evened up.

24×36 inches, or less	\$15 00
36×48 inches, or less	18 00
Larger than 36×48 inches	20 00

OVERHEAD POWER FIXTURES.

Consisting of countershaft, two adjustable hangers with oil cups, two cone pulleys, and driving pulley for main shaft.

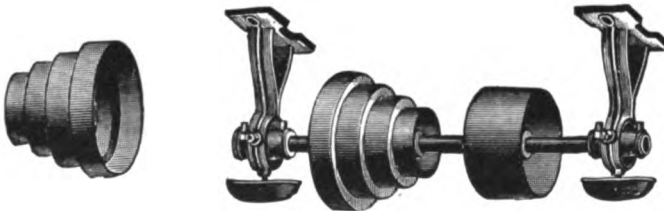

LIGHT FIXTURES FOR EIGHTH MEDIUM PRESSES AND SMALLER.

No. 1. 3 speed, 6 to 9 inches, belt 1 1/2 inches	\$15 00
No. 2. 4 speed, 7 to 10 inches, belt 1 3/4 inches	18 00

HEAVY FIXTURES.

No. 3. 3 speed, Eighth Medium	\$20 00
No. 4. 4 speed, Eighth Medium	22 50
No. 5. 3 speed, Quarto Medium	22 50
No. 6. 4 speed, Quarto Medium	25 00
No. 7. 3 speed, Half Medium	27 50
No. 8. 4 speed, Half Medium	30 00

Shafting, Hangers, Pulleys and Collars furnished to order at the lowest prices.

TRIBUNE NEWSPAPER FOLDER.

All Iron Frame.
Working Parts Steel and Iron.
All Movements Positive.
No Sprocket Chains.
No Lost Motion.

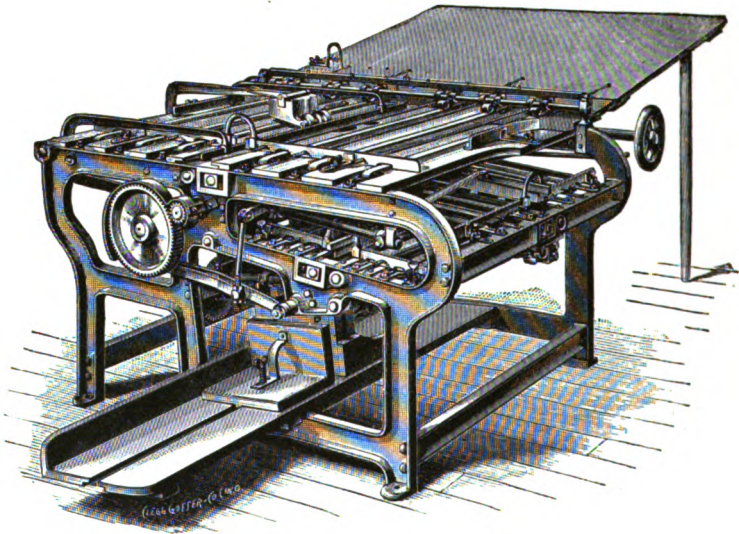

This is a folder of the highest grade of construction and efficiency, without a superior for its purpose on the market, and sold at such moderate net prices as to make so-called "cheap" folders highly expensive in comparison—durability and reliability considered. It has no makeshift devices. It folds on the same principle as the high-grade book machines. The simplest folder made.

Made in one size only, 36×48 inches, which takes in any size sheet, whether folio or quarto, from 22×32 to 36×48 inches.

Paster and trimmer can be furnished at time of purchase or added afterward.

Made with three- and four-fold deliveries. Three-fold work is delivered in a receiving box, while four-fold work is delivered in a packer, as shown in illustration.

In the hands of a competent operator it will fold ordinary sixteen- and thirty-two-page work.

Weight about 900 pounds. Power required, about one-tenth of one horse power. Speed, 300 folio or quarto sheets per hour.

LIST PRICES.

For hand feed	\$400 00
Paster and trimmer (no extra charge for this when insetting or covering attachment is ordered)	25 00
Fixtures for attaching to press, net	50 00 extra.

**TRIBUNE NEWSPAPER FOLDER.
LIST PRICES—Continued.**

- Inserting Attachment**, inserts a two-page or four-page sheet or supplement between the fourth and fifth pages of a publication, folding either ten or twelve pages and pasting and trimming the entire publication; net \$100 00 extra.
- Covering Attachment**, outsets two pages upon eight pages, making a ten-page publication; or outsets a four-page cover or supplement upon eight pages, making a twelve-page publication. It pastes and trims. Net 100 00 extra.

The net price of this thoroughly reliable and durable Folder is very little more than asked for inferior affairs which in the end will prove to be most expensive and least satisfactory. This Folder is made to do perfect work for many years.

UNIQUE IRON-FRAME FOLDER.

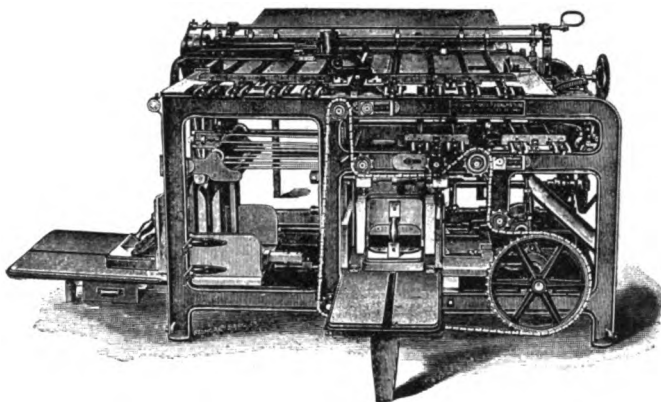

Built by the maker of the Bennett Economical Folder, shown on following page, to overcome the objections to wood-frame folders.

For hand-feed or attachable to any cylinder press, front or back delivery.

- To fold sheet 32×44 inches, three- and four-fold, with Paster and Trimmer for eight-page work \$300 00
- To fold sheet 36×50 inches, three- and four-fold, with Paster and Trimmer for eight-page work 300 00
- Folio Inserting Attachment 60 00
- Quarto Inserting Attachment 100 00
- Folio and Quarto Inserting Attachment, combined 125 00
- Quarto Covering Attachment 100 00
- Fifth or Post-Office Fold 75 00
- Hand Feed and Attachable in one machine 50 00
- Attachments for Front-Delivery Press 25 00

Floor space of 32 × 44-inch folder is 40 × 56 inches; of 36 × 50-inch folder, 46 × 62 inches.

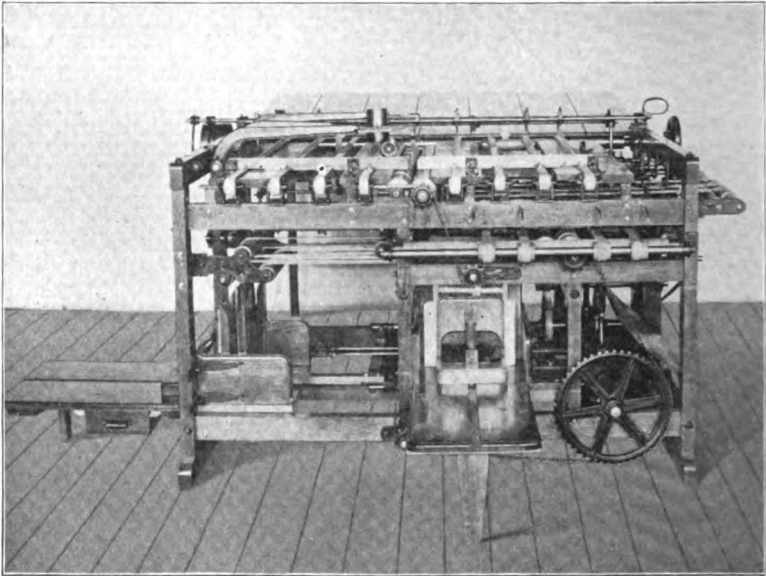
BENNETT ECONOMICAL FOLDER.

Has a strong, wooden frame, with working parts of iron. Delivers at third and fourth folds, and can be changed without stopping machine. Has pasting and trimming attachment for eight (8) page work. Built in hand-feed, or attachable to any cylinder press, front or back delivery. All journals are of tool steel, with journal boxes three diameters long, hung in self-adjusting pivot hangers, making it possible to remove any fold roll, driving or rock shaft in a few moments and replace in line, and there is not a gear on the machine but can be reached conveniently and removed easily. All adjustments are made by screw, each tape tightened independently, and drop of fold blades can be regulated by the "turnbuckle" adjustment to one-hundredth of an inch. There are side guides to insure accuracy in folding, whether a sheet comes from a press or feed-board.

No extra charge for press fixtures in attachable machines, except for front-delivery press.

LIST PRICES.

32×44 (6-Column Quarto), or 36×50 (7-Column Quarto), including Paster and Trimmer	\$240 00
Folio Supplement Attachment, with Paster	50 00
Quarto Supplement Attachment, with Paster	85 00
Folio and Quarto Supplement Attachment, combined	125 00
Cover Attachment for eight pages	100 00
Fifth or Post-office Fold	50 00
Hand Feed and Attachable in one machine	50 00
Attachments for Front-Delivery Press	25 00

THE BENNETT COUNTRY QUARTO FOLDER.

This machine is exactly the same as the Economical Folder, except that, instead of regular packing boxes at the third or fourth fold, it has a packing box at the fourth fold and a drop box at the third fold.

6 or 7-Column Quarto, including Paster and Trimmer	\$200 00
Hand feed or attachable to press.	

EMMERICH BRONZING MACHINE.

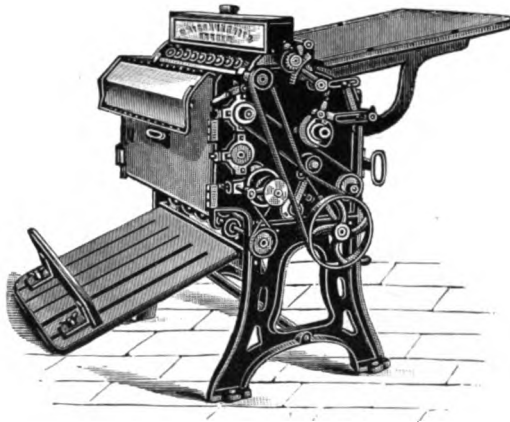

Over one thousand of these excellent machines are in use, and all give satisfactory results. They apply the bronze, polish and remove the superfluous powder, and deliver the sheet, bronzed side up, at a speed of two thousand on the smaller sizes. They are self-adjusting for all thicknesses of paper. They are made to be belted to a main shaft, and are equipped with belt shifter and tight and loose pulleys.

No.	Maximum Capacity.	Floor Space.	Weight Pounds.	Speed of Driving Pulley.	Diameter Driving Pulley.	Price f. o. b. factory.
1	9×15	24×30	320	330	6 inches	\$300 00
2	14×25	30×37	390	360	6 inches	375 00
3	16×30	44×50	600	110	10 inches	475 00
4	20×35	48×54	750	105	10 inches	550 00
5	25×40	54×58	900	90	10 inches	650 00
6	28×44	57×60	1050	140	13 inches	750 00
7	34×50	62×65	1225	140	13 inches	850 00
8	36×54	65×70	1350	140	13 inches	925 00

EMMERICH CARD BRONZING MACHINE.

Specially constructed for bronzing heavy stock that will not conform to a cylinder, such as photograph mounts, thick cards, etc. Both sides of cards are dusted at one operation. Forty photograph mounts per minute is the speed.

No.	Maximum Capacity.	Floor Space.	Weight Pounds.	Speed of Driving Pulley.	Diameter Driving Pulley.	
1	10 inches	24×34	350	200	8 inches	—
2	14 inches	28×37	420	200	8 inches	—
3	20 inches	34×40	525	175	10 inches	—
4	24 inches	38×45	650	175	12 inches	—

Prices will be quoted upon receipt of sample or description of work to be done.

For Prices of Bronzes and Hand Bronzing Devices, see page No. 3.

FOR STOCK ROOM AND BINDERY.

PEERLESS GEM PAPER CUTTERS.

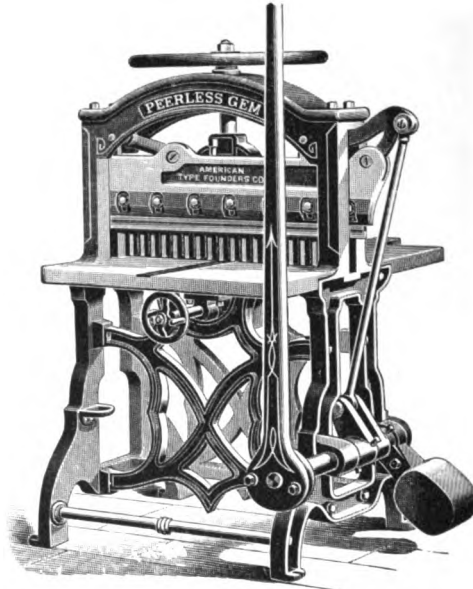

This illustrates the 30- and 32-inch Peerless Gem Paper Cutter, except that the balance weight is now hung inside the frame as shown in cuts of 23-inch size on next page.

Superior in every detail and in the leverage, cutting with greater ease to operator, and returning from cut with the least possible exertion, owing to their perfect balance. The frame is stronger, heavier and better braced; the knife thicker and deeper, insuring a truer cut and longer life; the lever is adjustable; the balance weight is now hung inside the frame, thus saving floor room. There are split back gauges, side gauges, and a front enameled measuring gauge. Unexcelled in construction, materials used, and finish.

Compare details of construction given below with those on other cutters.

23-inch, cuts 23 1/4 inches	\$100 00
25-inch, cuts 25 1/4 inches	125 00
30-inch, cuts 30 1/4 inches	175 00
32-inch, cuts 32 1/4 inches	200 00

DETAILS OF CONSTRUCTION.

	Weight, Unboxed.	Thickness of Knife Bar.	Thickness of Knife.	Depth of Knife.	Diameter Lever Shaft.	Diameter Steel Lever Connection Shaft.
30-inch	1340 lbs.	1 3/4 in.	1/2 in.	5 in.	2 in.	1 1/2 in.
32-inch	1425 lbs.	1 3/4 in.	1/2 in.	5 in.	2 in.	1 1/2 in.

25-INCH PEERLESS GEM CUTTER.

Excels all other cutters of its size in weight, ease of cut, strength, durability and finish. It is built on the same design as the Peerless Gem in all points, except that the lever is fixed on the shaft instead of being adjustable. The weight is 825 pounds, unboxed; has $4\frac{1}{2} \times \frac{3}{8}$ -inch knife; $1\frac{1}{4}$ -inch knife bar. The best money's worth ever offered in a 25-inch paper cutter.

The leverage both while cutting and returning is perfect, reducing the exertion of cutting to a minimum.

The balance weight is hung inside the frame to save floor space.



Style of 25-inch Peerless Gem Cutter.

25-inch, cuts $25\frac{1}{4}$ inches **\$125 00**

23-INCH PEERLESS GEM CUTTER.

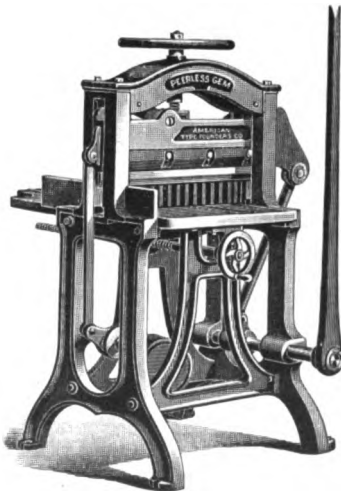

Style of 23-inch Peerless Gem Cutter.

No other cutter of this size, or about this size, equals the new 23-inch cutter. It weighs 725 pounds, unboxed; has $4\frac{1}{2} \times \frac{3}{8}$ -inch knife, and $1\frac{1}{4}$ -inch knife bar. Built on the Peerless-Gem principle, it has leverage of maximum power and easy return, and all the features of the 25-inch Peerless Gem Cutter. It is not possible to build a better cutter for the money asked.

The balance weight is hung inside the frame, thus saving floor space and removing an annoying obstruction.

23-inch, cuts $23\frac{1}{4}$ inches **\$100 00**

UTILITY PAPER CUTTER.

A thoroughly well-built cutter, without a superior of its size. Has side and back gauges, and a patent reversible clamp which cuts very narrow strips without marking the paper.

	Without Stand.	With Iron Stand.
Cuts and squares 16 inches	\$50 00	\$57 00
Cuts and squares 18 inches	60 00	67 00

EXTRA KNIVES.

16-inch	\$4 50
18-inch	6 00

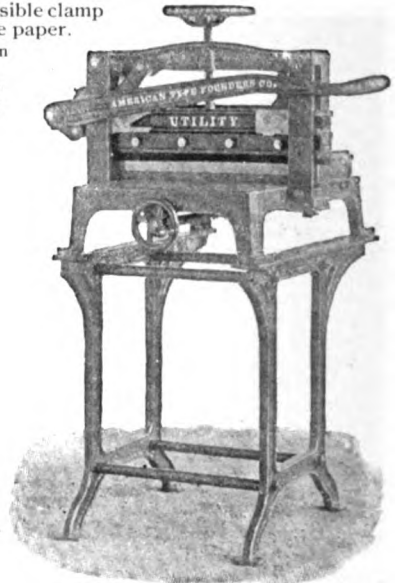

Utility Paper Cutter with Iron Stand.

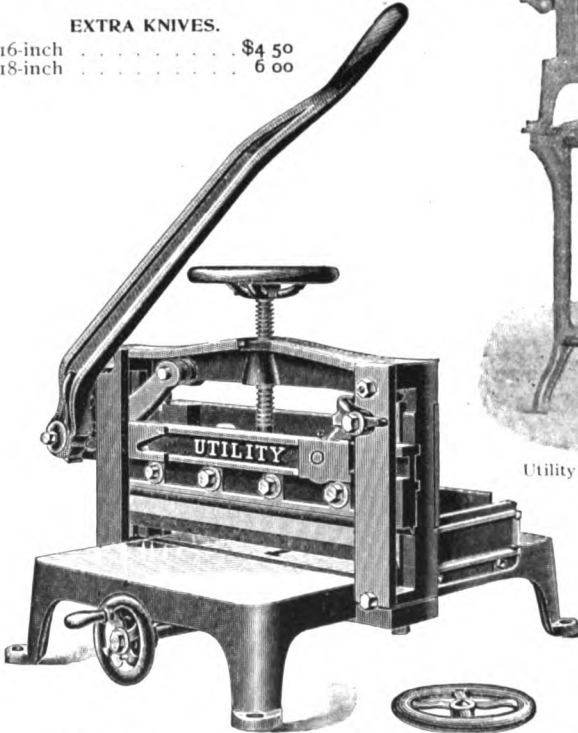

WITH IRON STAND.

Iron stands are made for each size, and are recommended where bench room should be saved.

CLIPPER PAPER CUTTER.

Designed for cutting small work, such as labels, circulars, etc. Has a patent reversible clamp, which cuts very narrow strips and leaves no marks on the paper. The lever is pulled forward to cut. Quality of construction is A1.

Cuts and squares 12 inches	\$40 00
--------------------------------------	---------

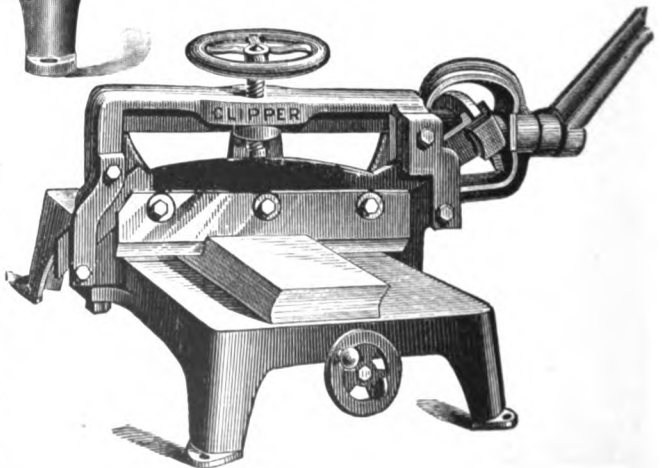

CHANDLER & PRICE PAPER CUTTER.

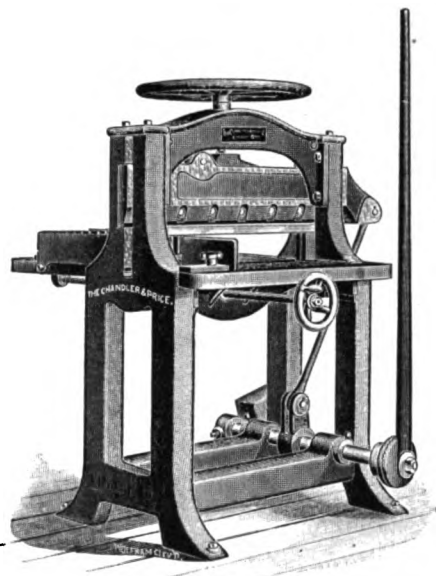

It is built from new designs by scientific methods. It has ample metal, properly distributed to withstand strains. The back gauge and clamp interlock, clamping as narrow as one-half inch. The fingers of the clamp have a broad surface, to avoid creasing the stock. All gauges are accurately squared with the knife. The back gauge extends to within one inch of the side gauge, and is divided and adjustable for book trimming or squaring small work. All parts are strictly interchangeable, and accurately fitting replacements may be ordered by number.

Made by one of the most reliable builders of printing machinery in the world.

23-inch	\$100 00
26-inch	130 00
30-inch	175 00

CHALLENGE LEVER PAPER CUTTER.

Has set screws and gibs in the frames for taking up wear of knife-bar.

The 25-inch cutter is provided with both front and back stationary side gauges, which are cast on the side frame, and are accurately squared to knife and back gauge. The 30-inch and 32-inch cutters have, in addition to these, an extra side gauge in front, adjustable to either side; also a split back gauge, useful in trimming pamphlets. They are provided with the interlocking back gauge and clamp, for cutting narrow widths, without extra cost.

25-inch	\$135 00
30-inch	200 00
32-inch	225 00

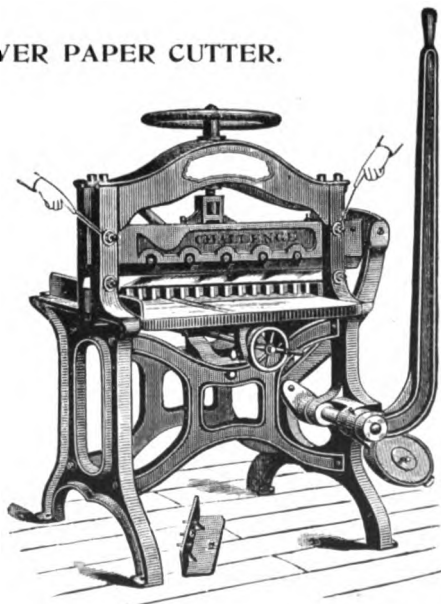

RELIANCE LEVER PAPER CUTTER.

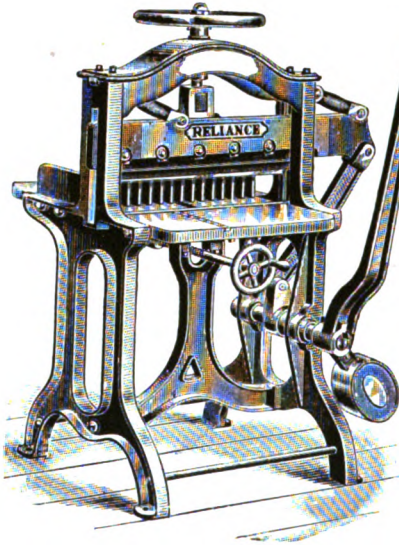

23-inch	\$90 00
25-inch	110 00
28-inch	135 00

ADVANCE LEVER PAPER CUTTER.

Its special feature is the arrangement for taking up wear in the slideway in which knife-bar moves, by means of steel gibs controlled by set screws.

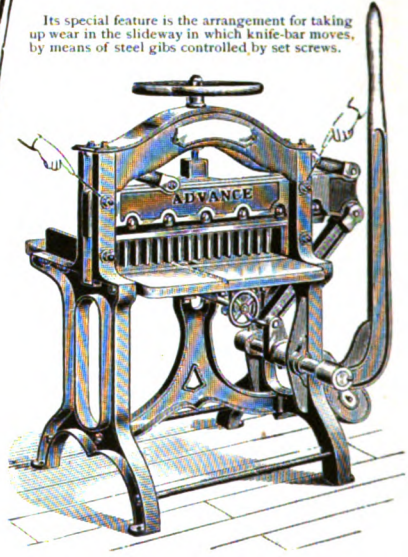

22 1/2 inch	\$ 90 00
25-inch	110 00
30-inch	165 00
33-inch	200 00

CHALLENGE PONY LEVER PAPER CUTTER.

Used in conjunction with larger cutters, small cutters such as these and the cutters shown on page 930 often double the cutting capacity of an office at a small additional plant expense.

The especial advantage of the 19-inch cutter is that it cuts the usual sizes of flat papers—cap, demy, folio, double cap, medium, and royal.

Prices include interlocking back gauge and clamp, permitting stock to be gauged within one-half inch of knife.

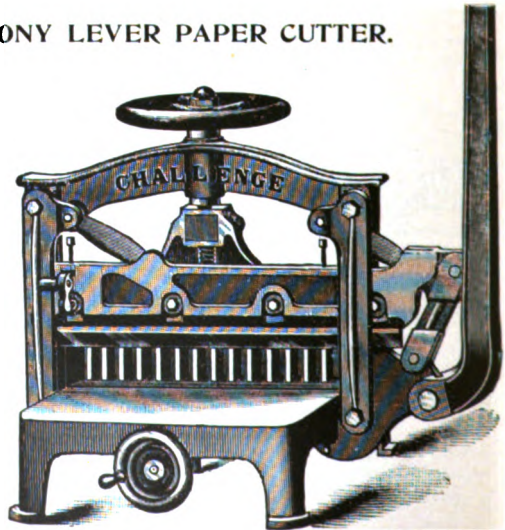

16-inch	\$50 00
19-inch	65 00

ADVANCE POWER CUTTER.

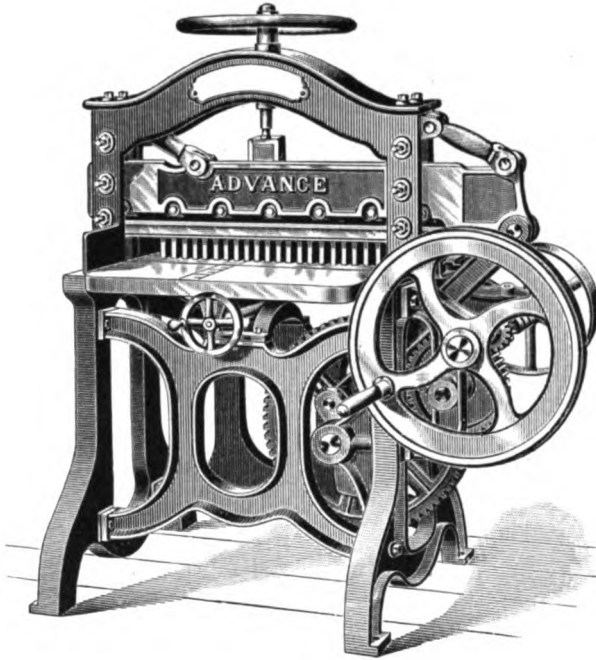

This is the lowest-priced Power Paper Cutter on the market, and can be recommended to buyers with whom low price is a prime consideration.

The Advance Power Cutter is fitted for hand or steam, is solidly built, the frame is firmly stayed by two substantial cross-braces, upon which is bolted the arch that supports the center of the bed, making it perfectly rigid and firm under pressure of clamp or knife.

It is fitted with the interlocking back gauge and clamp, by which paper may be cut to within half an inch of the knife.

It has brass figured rules in bed, back and front.

The throw-off is automatic and stops the knife instantly; it may be thrown off at any point, thus obviating possible waste of paper through error.

The knife has a dip-cut, which will be duly appreciated by all requiring a power paper cutter.

The slideways in which the knife bar moves is faced with steel gibs secured and adjusted by means of three set-screws on each side, so that any wear in the slideways may be taken up quite easily.

This is a very convenient style of cutter, as it will be found to be an effective and easily operated hand-power cutter at times when other power is not available.

30-inch, squares 30 inches	\$300 00
33-inch, squares 33 inches	350 00

PEERLESS POWER PAPER CUTTER.

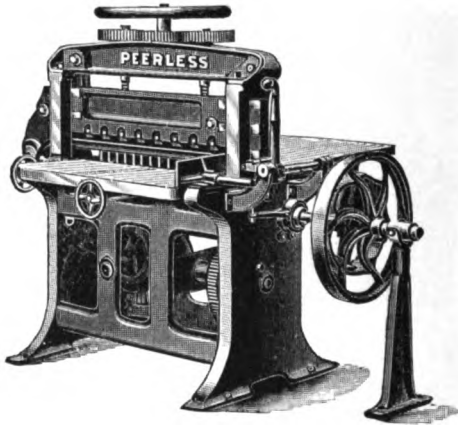

A powerful, compact, well-built cutter. The clamp is operated by two worm screws, which give it great firmness. Has interlocking back gauges and clamp, side gauges and measuring gauge. All movements are positive; all adjustments easy and rapid.

Cuts 36 inches square	\$650 00
Cuts 40 inches square	800 00

CHALLENGE POWER PAPER CUTTER.

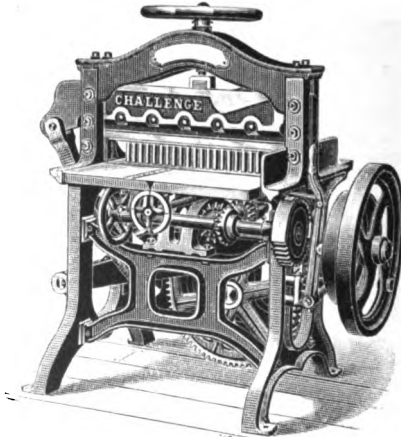

This cutter is provided with side gauges, back and front; an extra reversible side gauge for front table; split back gauge; interlocking back gauge and clamp, for cutting narrow widths; brass figured rules in bed, back and front. The slideways on which the knife bar moves are faced with gibs controlled by set screws, so that all wear in the slideways may be taken up.

30-inch, squares 30 inches	\$400 00	36-inch, squares 36 inches	\$650 00
32-inch, squares 32 inches	450 00	40-inch, squares 40 inches	750 00

SHERIDAN'S IDEAL CUTTER.

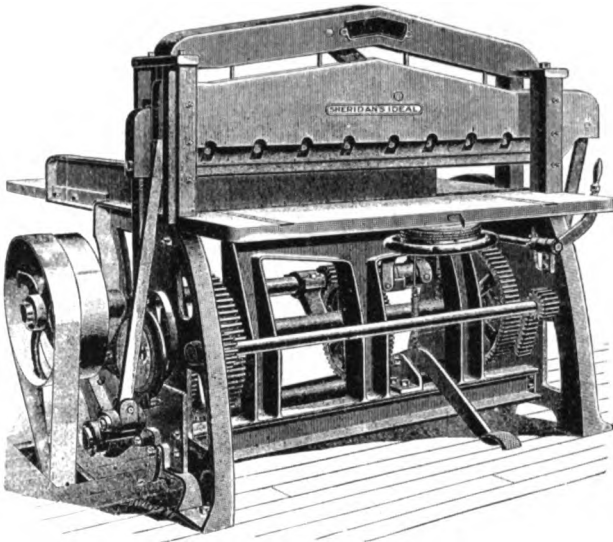

This cutter embodies the result of sixty years of labor and experience. Has all the desirable features of the well-known "Auto." Cutter, with the advantage that both clamp and knife are drawn down from both ends with no reverse motion of gear, thus securing an absolutely noiseless machine, with a positive and very powerful automatic clamp motion. All gears are cut and all shafts of steel.

Size. Ins.	Weight. Pounds.	Floor Space.	Pulleys. Inches.	Speed.	Price.	Boxing.
36 . . .	3600 . . .	6 ft. × 5 ft. 8 in. . . .	16 × 3½	300	\$ 700 00	\$10 00
40 . . .	4800 . . .	6 ft. 6 in. × 6 ft. . . .	16 × 3½	300	850 00	12 00
45 . . .	5100 . . .	7 ft. × 6 ft. 6 in. . . .	18 × 4	300	1000 00	15 00
50 . . .	7200 . . .	7 ft. 6 in. × 7 ft. . . .	18 × 4	275	1300 00	17 00
55 . . .	7550 . . .	8 ft. × 7 ft. . . .	18 × 4	275	1450 00	22 00
60 . . .	8050 . . .	8 ft. 6 in. × 7 ft. 6 in. . . .	20 × 4	275	1650 00	24 00
65 . . .	9000 . . .	9 ft. × 8 ft. . . .	20 × 4	275	1850 00	27 00
70 . . .	9400 . . .	9 ft. 5 in. × 8 ft. 6 in. . . .	20 × 4	275	2100 00	30 00

THE SHERIDAN POWER CUTTER.

Hand Clamp.

Size.	Price.	Boxing.
33 inches	\$ 550 00	\$ 9 00
36 inches	650 00	10 00
39 inches	725 00	12 00
43 inches	800 00	13 00
46 inches	900 00	15 00
48 inches	1000 00	17 00
53 inches	1200 00	20 00
56 inches	1400 00	22 00
63 inches	1800 00	25 00

FEISTER-BROWN SELF-CLAMPING PAPER CUTTER.

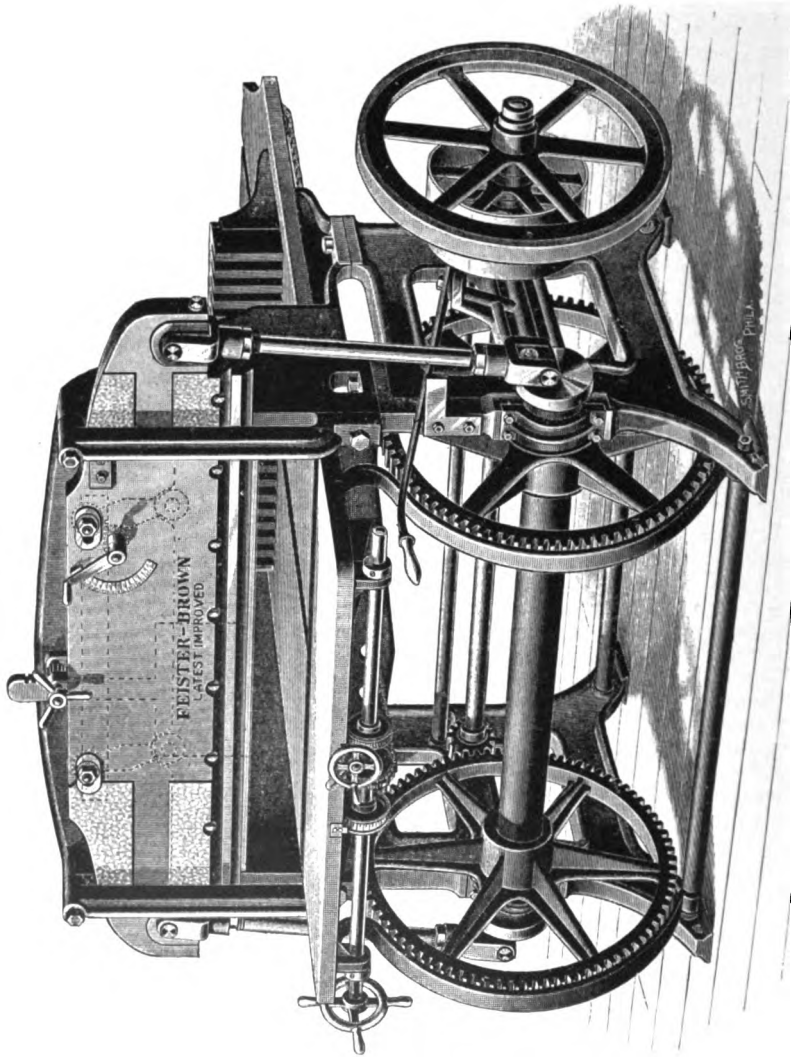

FEISTER-BROWN SELF-CLAMPING PAPER CUTTER.

See illustration on opposite page.

The automatic clamp on this cutter is so constructed that it can be made, by the turn of a lever, to clamp hard or easy, as the nature of the work may require. This clamp is actuated by a patent automatic parallel link motion that has only three working parts, which cannot get out of order. It will hold one sheet or five inches of paper with equal security. It is provided with an advance gauge which can be brought down to the work at will, in advance of the knife, and returned to its highest position whether the knife is moved or not.

The knife bar is actuated by a very strong shaft, fitted with cranks at both ends. These cranks have adjustable connecting rods attached to universal bearings on both ends of the knife bar and on the cranks (no awkward ball joints).

Motion is imparted to the crank shaft by twin gears and forged steel pinions, all placed inside of the machine frame, with the result that all strain of clamping and cutting is equally distributed over the whole machine frame (no oblique or twisting strains on the machine).

The machine is driven by one of the most complete friction clutches ever applied to a machine, which contains the fewest possible parts to be used to obtain the most durable and best results, and the machine can be run from twenty-five to thirty cuts per minute with ease and safety.

The whole upper portion of the machine frame, including table, side gauge, girder and top cross stay or arch, are cast in one solid, massive, rigid piece of iron. Not a bolt is used, therefore none can work loose, besides the machine has the advantage of being much truer and stronger than when bolted together in the old way.

The back gauge is made in two parts for printers' use and in three parts for book-binders' use, so that heads, tails and fronts of books can be trimmed without moving or changing it.

It is fitted with quick traverse movement, as well as hand-screw movement for "fine precision adjustment."

A measuring band, in convenient sight of the operator, indicates the sizes to be cut, both in front of the knife as well as between the back gauge and knife.

The back gauge is fitted with patent finger sections that slide so close on the table that the thinnest tissue cannot get under it. They also enter recesses in the clamp, so that the last of the stock can be cut up close to the knife. By this method there are no awkward grooves planed in the table to displace the under sheets, as used on some makes of machines.

This machine is a model of simplicity in construction. It contains but eight main moving parts. There is nothing about it to get out of order.

This cutter is the joint invention of Samuel Brown (inventor of the Brown & Carver Paper Cutter) and H. P. Feister (inventor of the Feister Perfecting Press and other well-known machines), and is the fruit of their very lengthy experience in constructing paper cutters.

LIST PRICES F. O. B. FACTORY.

Size.	Diameter and Width of Face of Driving Pulley.	Revolutions per Minute of Driving Pulley.	Floor Space.	Weight when Boxed.	Price.
35 inches	18×3 inches	275	6 × 5½ feet	3800 lbs. . . .	\$600 00
39 inches	18×3 inches	275	6½ × 6 feet	4300 lbs. . . .	725 00
45 inches	18×3 inches	275	7 × 6½ feet	4800 lbs. . . .	910 00
51 inches	22×4 inches	220	7½ × 7 feet	5700 lbs. . . .	1225 00
59 inches	22×4 inches	220	8 × 7½ feet	6100 lbs. . . .	1550 00
66 inches	22×4 inches	220	8½ × 8 feet	6800 lbs. . . .	1850 00

CUTTING STICKS.

	1/2 Inch Square.	3/4 to 1 1/2 Inch Square.	Round for Acme.
30-inch and under, per dozen	\$0 75	\$1 50	\$2 50
34-inch and under, per dozen	0 80	1 60	2 50
38-inch and under, per dozen	0 85	1 70	2 75
44-inch and under, per dozen	0 95	1 85	3 00
48-inch and under, per dozen	1 00	1 95	3 50
54-inch and under, per dozen	1 10	2 10	4 00

CUTTING STRIPS.

For Hamilton's Patent Cutting Stick, described below.

Under 38 inches, per dozen, net	\$0 25
38 inches and not exceeding 54 inches, per dozen, net	0 40
54 inches and longer, per dozen, net	0 50

HAMILTON PATENT CUTTING STICK

Consists of a main body piece (A), made to fit the groove of your paper cutter. The body piece has a groove or recess in it, which holds a small strip (B) one-quarter of an inch square. This removable strip is the cutting surface, and is held in place by a steel clamp (C), which is drawn up by the bolts (D). The cutting strips, being square, can be used on four sides, thus giving the same amount of service as the large-size sticks heretofore used.

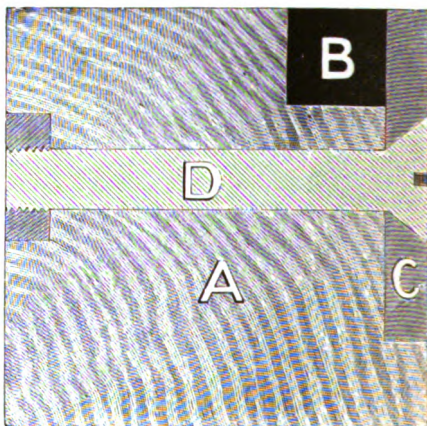

SEE THAT B ?

- A** is the body piece made to fit groove in cutter.
- B** is the cutting strip on which knife strikes. It is one-fourth inch square, and is just as effective as if it was one and one-quarter inch square, also cheaper, and always fits.
- C** is the steel clamp which holds the cutting strip and prevents warping.
- D** is the screw which grips the clamp to the body piece.

ADVANTAGES.

1. The steel strip or clamp (C), running the extreme length of the main body piece, and firmly screwed thereto, effectively prevents springing and warping, which cannot be prevented on ordinary cutting sticks.
2. There is no wear on the body piece, and as it is fitted exactly to the groove of your cutter your troubles from ill-fitting sticks (necessitating packing, etc.) cease.
3. The cutting strips are all made to a uniform standard and are interchangeable, and thus there is an absolute certainty of them fitting.

HOW TO ORDER.

1. Give size square the main body piece is to be. Be particular on this point, and see that groove in cutter is accurately measured. 2. Give length of stick. 3. State how far from front edge of stick the knife strikes. 4. State whether knife cuts from right to left or left to right. In ordering cutting strips give the exact length required. All strips are cut to a standard uniform gauge, and are sure to fit.

Main body piece, under 38 inches long, net	\$5 00
Main body piece, 38 inches to 54 inches long, net	6 00
Main body piece, 55 inches long and over, net	7 00
Cutting strips, under 38 inches long, per dozen, net	0 25
Cutting strips, 38 inches to 54 inches long, per dozen, net	0 40
Cutting strips, 55 inches and longer, per dozen, net	0 50

AUTOMATIC KNIFE GRINDERS.

Knife grinders have become a necessity in large printing offices, as well as in offices remote from grinding establishments, as in the latter the saving not alone of the cost of grinding, but of expressage, delays, and extra knives will very soon pay for the cost of a knife grinder.

Two styles are made. In the light pattern, as illustrated on this page, the slide or knife holder is moved by hand against the emery wheel, which is turned by power.

The weight of the 32-inch size is 550 pounds, boxed. The tight and loose pulleys are six inches in diameter, and should run at 1100 revolutions per minute.

The grinder is adjustable for flat or concave grinding. The emery wheels are eight inches in diameter, with three and one-half inch face, and can be used up almost entirely. Extra wheels cost \$4.00 each, net.

In ordering light or heavy pattern grinders it is necessary to send accurate description of knives to be ground. Knife holders are made to suit any knife without extra charge.

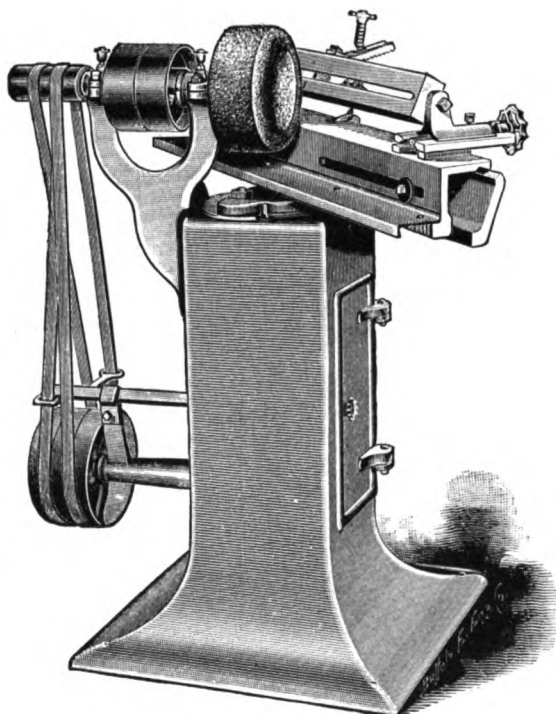

Style of Light Pattern Grinder.

NET PRICES OF LIGHT PATTERN (STYLE B) GRINDERS.

	Complete		Complete
Grinds knives up to 26 inches . . .	\$ 75 00	Grinds knives up to 54 inches . . .	\$130 00
Grinds knives up to 32 inches . . .	85 00	Grinds knives up to 60 inches . . .	140 00
Grinds knives up to 44 inches . . .	105 00	Attachments for water, extra . . .	10 00

HEAVY PATTERN AUTOMATIC KNIFE GRINDER.

In this style the knife holder is moved by power, and reverses automatically. The knife holder can be set at different angles from the emery wheel, which has a flat face with the corners rounded off. If the bed is set at a right angle to the emery-wheel spindle, the knife moves back and forth against the face and is ground a flat bevel; if it is set at any other angle the rounded corner will do the grinding and the bevel will be concave. This feature will be appreciated by those who prefer a flat, stout edge for rough work, and a thin, concave edge for fine work. The emery wheels are twelve inches in diameter with four-inch face, and can be used up almost entirely. Extra wheels cost \$7.00 each, net. The tight and loose pulleys are eight inches in diameter, and should run at 800 revolutions per minute. Weight of the 108-inch grinder is 1800 pounds. A perfect water attachment is supplied, the water being delivered in any desired quantity on the bevel of knife by means of a brass centrifugal pump.

NET PRICES OF HEAVY PATTERN (STYLE A) GRINDERS.

	Complete		Complete
Grinds knives up to 54 inches . . .	\$200 00	Grinds knives up to 90 inches . . .	\$280 00
Grinds knives up to 60 inches . . .	215 00	Grinds knives up to 96 inches . . .	310 00
Grinds knives up to 76 inches . . .	235 00	Grinds knives up to 108 inches . . .	350 00
Grinds knives up to 84 inches . . .	260 00		

BOSTON CARD CUTTERS.

With Accurate Gauges.



No. 24. With 24 1/2-inch blade.

These cutters have iron frames and polished hard-wood tables. The Nos. 12 and 24 sizes have accurate front, side and back gauges. The front gauge is operated by racks and pinions which hold the gauge securely at each end, and move it exactly parallel with the knife. No clamp is required, as the knives have a drawing cut, which keeps the sheet straight.

The No. 12 size will cut any length of sheet in two or more cuts, as the standard that holds the knife bar is on its inner side in line with the cutting edge, as shown in the cut. The No. 8 size has a reversible gauge, which may be used either at front or back.

- No. 8, with 8 1/2-inch blade \$ 8 50
- No. 12, with 12 1/2-inch blade 12 00
- No. 24, with 24 1/2-inch blade 20 00

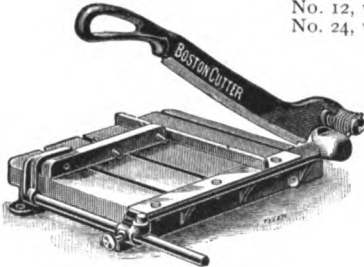

No. 8. With 8 1/2-inch blade.



No. 12. With 12 1/2-inch blade.

SUCCESS CARD CUTTER.

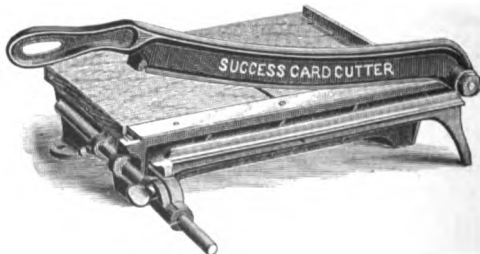

A well-made, reliable cutter, with movable side and front gauges. 12-inch knife. \$10 00

MONITOR TABLE SHEARS.

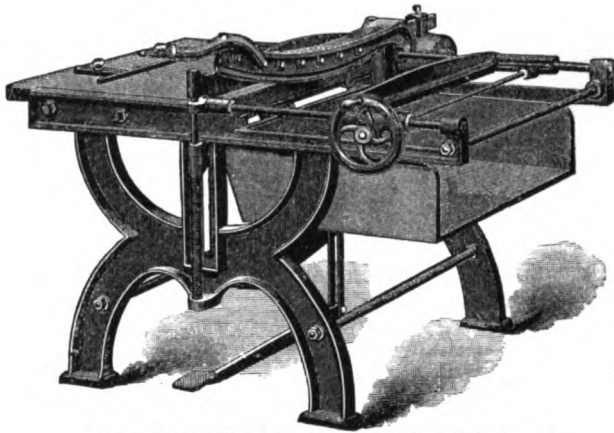

Style of 34-inch Extra Heavy Monitor Table Shears.

Two styles are made : No. 1, 32-inch, for general use, and No. 2, 34-inch, extra heavy, for work that demands greater power. The knife, gauges and method of operation are the same on each style. The knife-bar head is adjustable laterally and vertically, and another adjustment at the head enables the knife bar to be swung either way, so as to secure its perfect alignment with the bed, and insure a perfect shear cut. The screws holding the knife-bar head are $1\frac{3}{8}$ inches in diameter, and are turned at an angle of 55 degrees, which prevents the knife bar from springing. The clamp is parallel, and descends upon the whole length of sheet at once when the foot is placed on the clamping treadle. The gauge is operated by a hand wheel attached to a geared pinion and rack. The rack is of steel. One revolution of the hand wheel moves gauge four inches. The table is scored both ways, and is provided with side and end adjustable gauges.

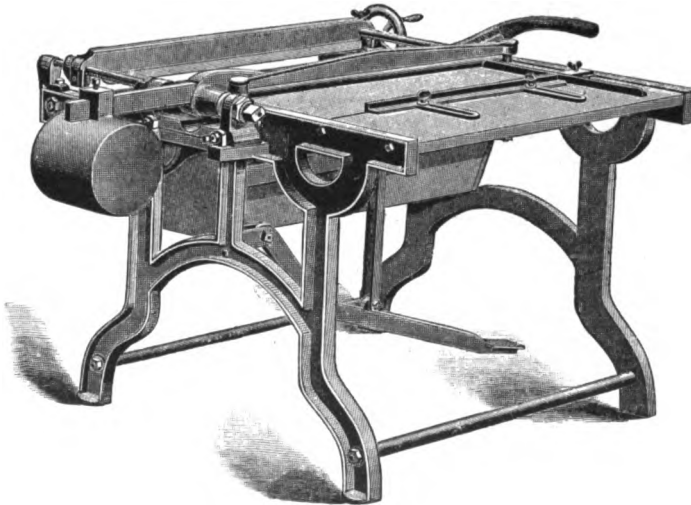

Style of 32-inch Monitor Table Shears.

No. 1, all iron, 32 inches	\$110 00
No. 2, all iron, 34 inches, extra heavy	150 00

BATES AUTOMATIC NUMBERING MACHINES.

These very superior machines operate consecutively, duplicate and repeat, and the changes are made instantaneously by simply moving the pointer on the dial. The figures are cut in steel, and print perfectly. The movement of the figures is entirely automatic from 1 to the full numerical capacity of machine. The figures receive ink automatically from a thick felt pad. The mechanism, materials and finish are unsurpassed. All parts are interchangeable, and the operation is noiseless. Weighs about 16 ounces. Styles of figures follow:

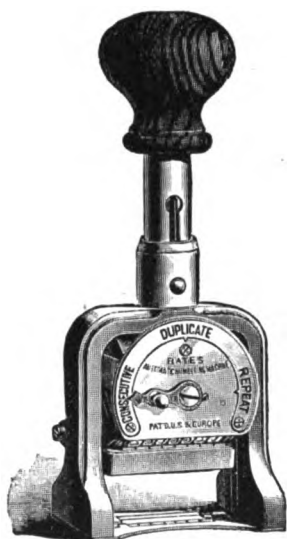

Bates Machine, one-half actual size.

- A 12345
- E 12345
- Q 12345
- F 12345

Styles E and Q are kept in stock and A and F are furnished to order at short notice.

4 wheels, numbering to	9,999	\$12 00
5 wheels, numbering to	99,999	14 00
6 wheels, numbering to	999,999	16 00
7 wheels, numbering to	9,999,999	18 00

Prices include ink and pad.

PARAGON NUMBERING MACHINE.

A machine of a cheaper grade, but accomplishing the same work as the Bates, the chief difference in method of construction being in the dial-changer. In this machine the changes are made by inserting a pin in the holes opposite the indicators.

4 wheels, numbering to	9,999	\$ 8 00
5 wheels, numbering to	99,999	9 00
6 wheels, numbering to	999,999	10 00
7 wheels, numbering to	9,999,999	12 00

Each machine in wood box, with bottle of ink.

In ordering state style of figures required. Paragon Machines with Gothic figures can be supplied at same prices.

- R 1234567890
- s 1234567890
- T 1234567890
- w 1234567890



MONITOR PAGING AND NUMBERING MACHINE.

For Treadle or Steam Power.

STYLES OF FIGURES.

There are 27 styles of figures made for this machine. We have space to show only the styles most in use.

E
576348

I
4825

K
3574

Q
258643

O
324510

W
253760

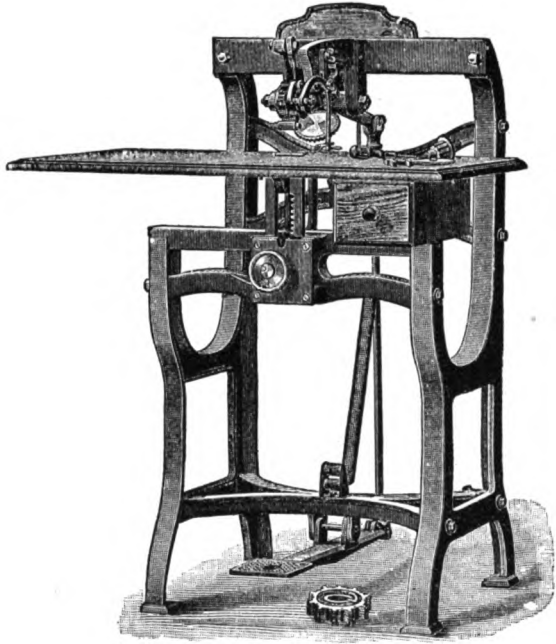

A reliable, well-constructed machine, with steel numbering heads, which by changing a single hand screw will number consecutively or alternately from 2 to 4 to 6, and so on, or from 1 to 3 to 5, and so on, or by the use of a repeating wheel fastened by a single hand screw will repeat a number any desired number of times. The table is adjustable up and down. The foot-power machines are made with journal boxes, so that power fixtures may be added at any time.

	For Power and Treadle.	For Treadle.
With one four-roll steel figure-head	\$225 00	\$175 00
With one six-roll steel figure-head	235 00	185 00
With one four-roll and one six-roll steel figure-head	285 00	235 00

Prices for machines for power include countershaft and hangers. If these are not required, the prices of power machines will be \$30 00 additional to prices of treadle machines.

STEEL PAGING AND NUMBERING FIGURE-HEADS.

Four-roll, to number 10,000	\$50 00
Five-roll, to number 100,000	60 00
Six-roll, to number 1,000,000	70 00
Extra repeater	3 00

Prices of numbering heads include one repeater. Styles of figures sent on application.



Acme Staple Binder No. 6. For treadle, with flat and saddle tables.

Price, \$40.00

PRICES OF ACME TREADLE STAPLE BINDERS.

No. 6 Acme Wire Staple Binder, capacity $\frac{1}{4}$ -inch and under, on all kinds of paper, for round or flat wire, with table and treadle complete	\$40 00
No. 4 Acme Wire Staple Binder, capacity $\frac{1}{4}$ -inch and under, on ordinary printing paper, for round fine wire only, with table and treadle complete	27 00

For Prices of Staples, see next page.

No. 6 ACME TREADLE STAPLE BINDER.

**The Only Staple Binders
Which Will Not Clog.**

The No. 6 Acme Wire Staple Binder does a greater range of work, and does better work, than any other staple binder. At one stroke of the treadle it drives, clinches and releases the staple, each operation being independent, though continuous. It holds two hundred and fifty staples at a charge, and round or flat and fine or coarse staples may be used. Staples are fed automatically to driver by positive pressure on both legs, and clogging is prevented by a device which effectually prevents more than one staple getting under the driver at a time. The clinch is perfect on any thickness. There is ample room for putting in and taking out work, as the driver arm lifts more than an inch above the table after each clinch. There is a long space under the arm for calendar work. The treadle has a positive movement. Every machine is furnished with a strong iron stand. Will bind to a thickness of $\frac{1}{4}$ inch through any kind of paper, and is furnished with both flat and saddle-back tables, with gauges on the flat bed. For hard or coated papers, when the work is heavy, flat wire staples are used.

No. 4 ACME TREADLE STAPLE BINDER.

**The Only Staple Binders
Which Will Not Clog.**

The No. 4 Acme is very similar in appearance to the No. 6, and will stitch the same thickness on ordinary paper, but it uses only round fine staples, which cannot be used successfully on coated or filled paper unless such work is light. This machine is specially adapted for stapling the average run of pamphlets, calendars, sample work, etc. It does both flat and saddle-back work. It has the device for prevention of clogging, and the clinching is done by the pressure of the blade while driving the staple. Holds two hundred and fifty staples at a charge.

**UTILITY OF THESE
MACHINES.**

The addition of one of the Acme Treadle Staple Binders to the plant of small or moderate-sized printing offices, in towns in which there are no binderies, will make it easy and profitable to bind pamphlets, receipt books and other work. In towns where there are binderies they enable printers to save time, save handling of stock, and to avoid losses and damage in transit. All the staple binding machines in use were invented by one man, and the Acmes are the latest and most efficient. Like all such machines there is a certain knack to be acquired in order to handle them to the best advantage. Operators should read directions (which accompany the machines) very carefully.

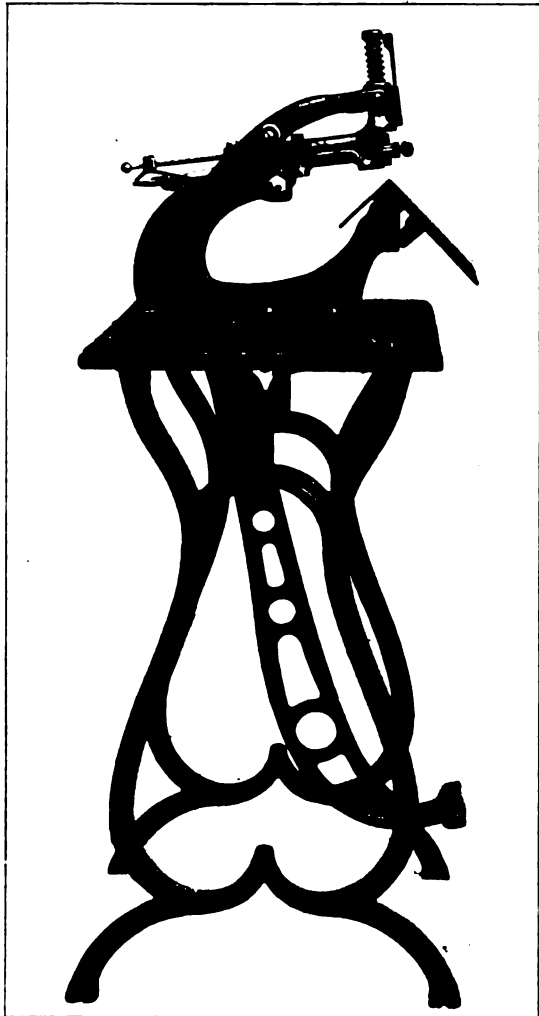

Acme Staple Binder No. 4.

Price, \$27.00

STAPLES FOR ACME BINDERS.

For Acme Binder No. 6: No. 21, 1/4-inch, round; No. 22, 5/16-inch, round; No. 23, 1/2-inch, flat; No. 24, 5/16-inch, flat—per box of 5000 of one size \$1 25
 For No. 4: No. 21, 1/4-inch, round, and No. 22, 5/16-inch, round—per box of 5000 of one size 1 25

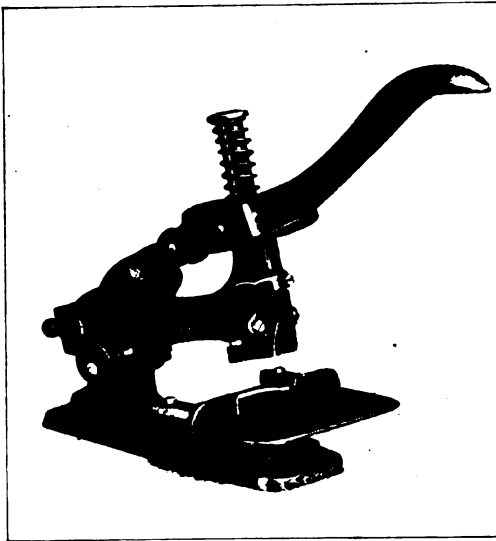

ACME STAPLE BINDER

No. 1.

The most satisfactory low-priced staple binder made. *It will not clog*, as only one staple can get under the driver at one time. The frame swings on a pivot, and lifts high enough to give ample room for putting in and taking out the work—an advantage not obtainable on other low-priced staple binders. It holds one hundred staples at a charge. Binds $\frac{1}{4}$ -inch and under. The staple is fed automatically under the driver, which descends and drives it through the paper, the pressure clinching the staple tight on the under side. Uses flat staples only.

Price \$5 00
Staples: No. 23A, $\frac{1}{4}$ -inch, flat; No. 24A, $\frac{3}{16}$ -inch, flat—per box of 5000 of one size . . . 1 25

SURE SHOT STAPLE BINDER

No. 1.

The most reliable binder for office use. Holds one hundred staples at a charge. Works on the same principle as the Acme No. 1, described above, but has no lever. Binds from two to fifty sheets.



Price \$3 00
Staples: No. 23A, $\frac{1}{4}$ -inch; No. 24A, $\frac{3}{16}$ -inch—per box of 5000 of one size 1 25

**BREECH LOADER
STAPLE BINDER.**

This is a handy machine for office use. Can be put to a great variety of uses. Binds paper or pamphlets from two to fifty sheets with wire staples; holds one hundred staples at a charge; feeds them out automatically; inserts them into the work, and clinches them on the under side.

Price \$3 00
Staples: C, $\frac{3}{16}$ -inch; D, $\frac{1}{4}$ -inch; E, $\frac{5}{16}$ -inch—per box of 1000 0 50

Only one size of staples in a box.

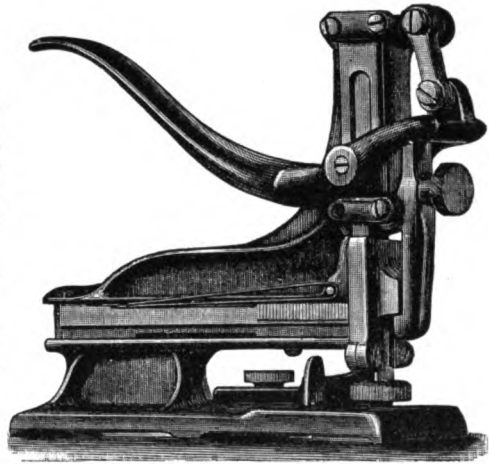

**HERCULES
WIRE STAPLE
BINDER.**

For Hand or Treadle.

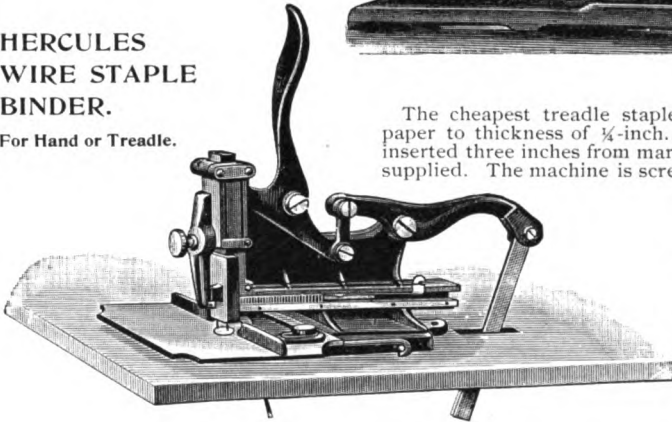

The cheapest treadle staple binder. Binds paper to thickness of $\frac{1}{4}$ -inch. Staples can be inserted three inches from margin. No table is supplied. The machine is screwed on a bench, and the treadle is screwed to the floor, connecting by means of a rod and spring.

Sold also for hand power only. Only one size of staples in a box.

Price, with treadle \$10 00
Staples: F, $\frac{3}{16}$ -in.; G, $\frac{1}{4}$ -in.; H, $\frac{5}{16}$ -in.; K, $\frac{3}{8}$ -in.—per box of 5000 of one size 1 25

OTHER STAPLE BINDERS.

No. 9 Staple Binder binds paper $\frac{1}{4}$ -inch thick, complete with table and treadle . . . \$36 00
No. 8 Saddle Back Staple Binder takes $\frac{3}{16}$ -inch staples only; designed for saddle-back work, but will take flat work by adding flat table; with saddle back only, \$30 00; with flat and saddle-back tables 31 50
Lightning Staple Binder No. 1 staples through $\frac{1}{4}$ -inch paper; No. 2 staples through $\frac{3}{16}$ -inch paper; each complete with treadle 24 00

WIRE STAPLES.

The prices for staples for the wire staple binders illustrated on this and preceding pages are given under the description of each binder. The following are the prices of staples for the binders not illustrated:

For No. 9 Staple Binder: Staples No. 1 $\frac{1}{2}$, $\frac{3}{16}$ -inch long; No. 2, $\frac{1}{4}$ -inch long; No. 3, $\frac{5}{16}$ -inch long—per box of 5000 of one size \$1 25
For No. 8 Saddle Back Staple Binder: Staples No. 1, $\frac{3}{16}$ -inch long—per box of 5000 1 25
For Lightning Staple Binder No. 1: Staples No. 7, $\frac{3}{16}$ -inch long; No. 8, $\frac{1}{4}$ -inch long; No. 9, $\frac{5}{16}$ -inch long—per box of 5000 of one size 1 25
For Lightning Staple Binder No. 2: Staples No. 10, $\frac{3}{8}$ -inch long; No. 11, $\frac{1}{2}$ -inch long; No. 12, $\frac{1}{2}$ -inch long—per box of 5000 of one size 1 25

MONITOR AUTOMATIC WIRE STITCHERS.

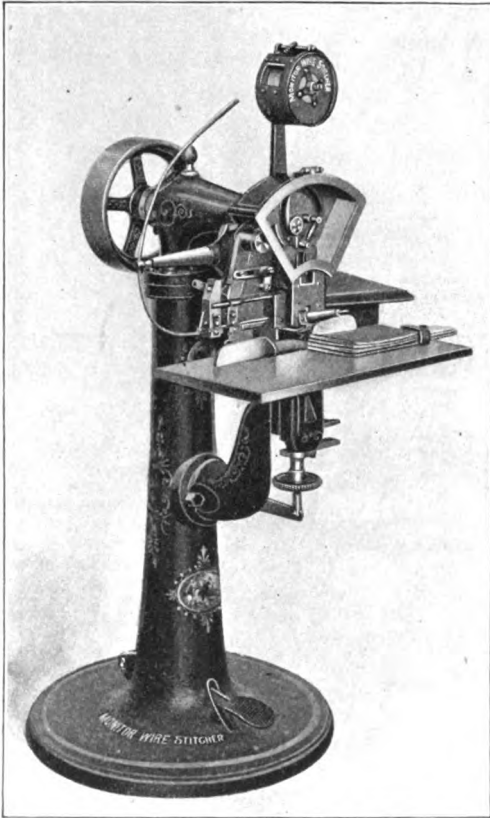

Style of No. 0, 1, 1½ and 2½ Monitor Wire Stitchers.

These very efficient stitchers do a range of work from two sheets to work 1¾-inch thick.

ADJUSTMENTS.

There are only two adjustments: 1. The quantity of paper to be stitched is put in the thickness gauge, and the hand wheel at left of gauge is turned until the jaws clamp the paper tight. 2. Turn the hand wheel at right of machine to obtain proper length of staple, then turn the thumb-screw on the feed lever at the left to the same point on the scale.

TWO STYLES MADE.

These stitchers are made with both roll-feed and straight-feed. The straight-feed machines have the advantage of lower price, but the roll-feed give the use of a greater range of thicknesses of wire, as explained below. On the roll-feed machines the wire passes through metal rollers which hold it firmly and smooth out all twists and bends in the wire. The roll-feed apparatus is automatic, and the lengths of staples can be changed without taking off any parts of the machine. We recommend the roll-feed machines, except on the No. 0 size.

SPECIAL MACHINES.

The No. 2½ is made specially for stitching calendars, and has a long reach back and a long drop, so that the stitch can be made 10 inches from edge of the work. The drop is 16 inches. The No. 0, if specially ordered, can be supplied with an Automatic Clamp, which compresses the paper about to be stitched before the wire touches it. This is a valuable attachment where the paper is soft and spongy. It saves the operator the trouble of pressing the paper down with his hands, and very greatly increases the output of the machines.

THICKNESS OF WIRE USED AND LENGTH OF STAPLES.

Straight-feed Machines.—No. 0 makes a staple 1¼-inch wide and uses No. 19 - 21½ flat wire only. No. 3 makes a staple ½-inch wide and uses Nos. 25 and 27 round wire, unless specially ordered for flat wire, when it uses No. 20 - 25 flat wire and No. 25 round wire only. Nos. 1, 1½ and 2 machines make staples ½-inch wide, and use No. 20 - 25 flat and No. 25 round wire.

MONITOR AUTOMATIC WIRE STITCHERS.

(Continued.)

Roll-feed Machines.—Nos. 1, 1½ and 2 make staples ½-inch wide and use round wire from Nos. 25 to 30 inclusive, and No. 20×25 flat wire. Nos. 2½, 3 and 4 make staples ¼-inch wide and use round wire only, Nos. 25 to 30 inclusive.

See Price List of Wire on page 951.

PRICES AND CAPACITIES OF MONITOR AUTOMATIC WIRE STITCHERS.

	Straight-feed.	Roll-feed.
No. 4, complete, capacity 2 sheets to ½-inch		\$100 00
No. 3, complete, capacity 2 sheets to ¼-inch	\$150 00	165 00
No. 2½, complete, for calendars, capacity 2 sheets to ¼-inch (stitches 10 inches from edge of work)		175 00
No. 2, complete, capacity 2 sheets to ⅜-inch	200 00	200 00
No. 1½, complete, capacity 2 sheets to ½-inch	300 00	300 00
No. 1, complete, capacity 2 sheets to ¾-inch	400 00	450 00
No. 0, complete, capacity ¼-inch to 1⅜-inch	550 00
No. 0, complete with Automatic Clamp, capacity ¼-inch to 1⅜-inch	600 00

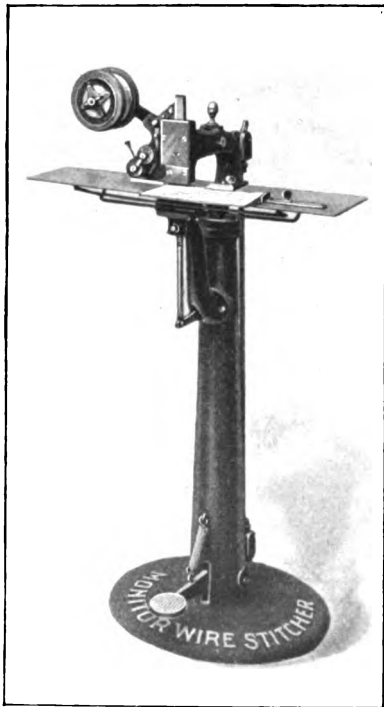

Style of No. 4 Monitor Wire Stitching Machine.

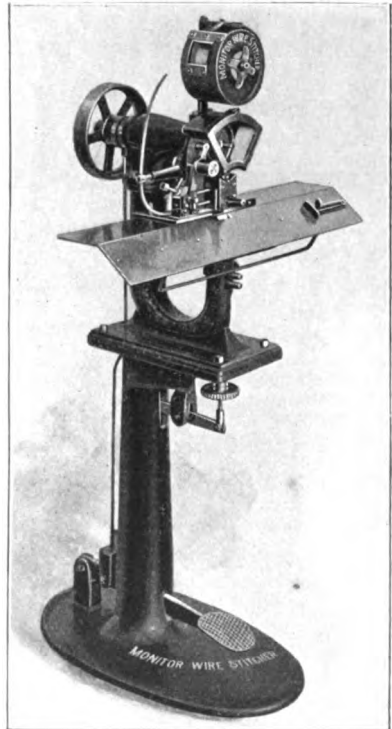

Style of Nos. 2 and 3 Monitor Wire Stitching Machines.

PERFECTION WIRE STITCHERS.

Perfection Stitchers, as shown on this and following page, have for a number of years given invariable satisfaction with a minimum of trouble. They are exceedingly well made and strong. The adjustment from one length of staple to another is accomplished by changing a pin from one hole on dial plate to another.

These stitchers take wire from spools, and make staples from round or flat wire of any desired length within the capacity of each machine.

PERFECTION "G" WIRE STITCHER.

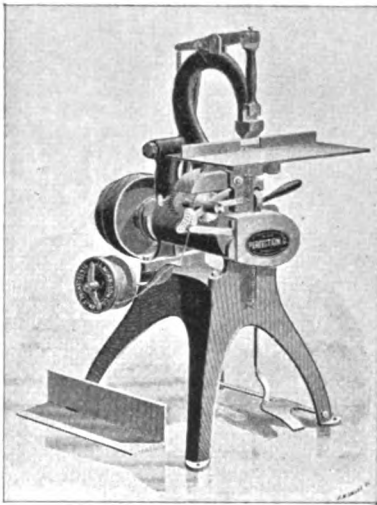

Power or Treadle.

Capacity, two sheets to almost $\frac{3}{4}$ -inch. Large trough and flat table. Uses 20 to 28 gauge wire.

For steam power \$250 00
 For treadle and power combined 265 00
 For treadle only 260 00

No. 7 NEW PERFECTION WIRE STITCHER.

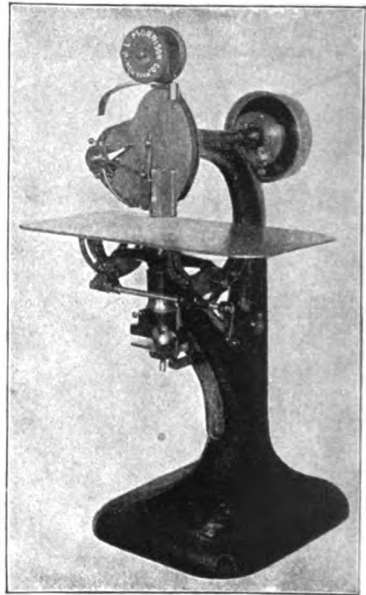

This machine has all modern improvements. It sets automatically for all thicknesses of work. The patent table is changeable from flat to saddle, or *vice versa*, without removal. There is an extra length of space between clinchers and

frame to accommodate large calendars and extra large publications. Constructed expressly to stitch heavy work with light wire, without change of parts, although heavy wire can be used if desired. Has the roller-feed device in its latest improved form, and patent supporting and clinching devices which are unexcelled.

Will stitch from one sheet to $\frac{1}{4}$ -inch, and will run wire as fine as No. 25, and also flat wire, 21 - 25, without changing any parts.

Price, complete \$300 00

For Prices of Wire, see page 951.

PERFECTION "A" WIRE STITCHER.

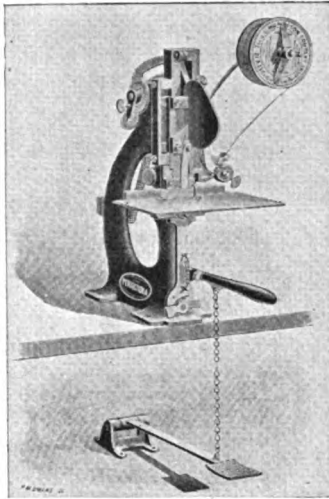

Hand or Foot Power.

It is adapted for work varying from two sheets to one-fifth inch in thickness. May be used with flat table or saddle, with wire of from 23 to 30 gauge. The saddle is extra long.

Perfection "A" Wire Stitcher, for hand or foot power \$90 00

PERFECTION "C" WIRE STITCHER.

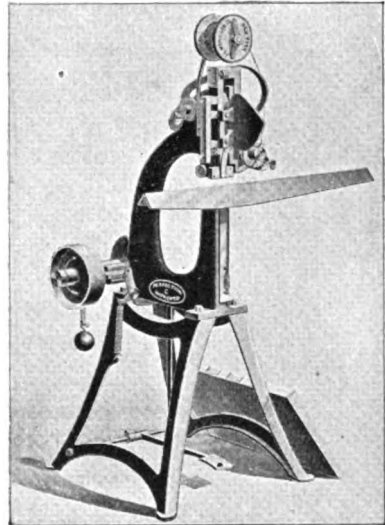

For Steam Power Only.

Specially adapted for pamphlet binding, stitching calendars, and all work up to one-fifth inch. Extra long saddle and flat table. Takes 23 to 30 gauge wire.

Perfection "C" Wire Stitcher, for steam power only \$150 00

PRICE LIST OF BOOKBINDERS' WIRE ON SPOOLS.

Discount on Quantities. Prices Subject to Change Without Notice.

The success of every wire stitching machine depends largely upon the quality of the wire used. This wire is the best made.

A spool holds five pounds of wire. A case contains 20 spools (100 lbs.). Spools are 10 cents extra each, and are returnable less transportation charges. Do not return spools without previously sending us notice, as such notice may enable us to save you some expense.

Gauges of Wire.		100-Pound Lots.	500-Pound Lots.	1000-Pound Lots.
Round:	Nos. 18 and 19	\$0 10	\$0 09	\$0 08½
	Nos. 20, 21, 22	0 11	0 10	0 09
	Nos. 23, 24, 25, or 30 s.	0 12½	0 11	0 10
	Nos. 26, 27, 28	0 15	0 14	0 12½
	No. 30	0 18	0 17	0 16
Flat:	Nos. 19×21, 19×21½, or 10 s.	0 16	0 15
	Nos. 20×23 and 20×25	0 17	0 16
	Nos. 21×25 or 60 s.	0 18	0 17
	Nos. 24×29	0 19	0 18

* * * No. 25 wire is sold in single spools at 25 cents per lb. Wires Nos. 10 s, 30 s, and 60 s, are for Thompson machines only.

BOOKBINDERS' WIRE ON SPOOLS.

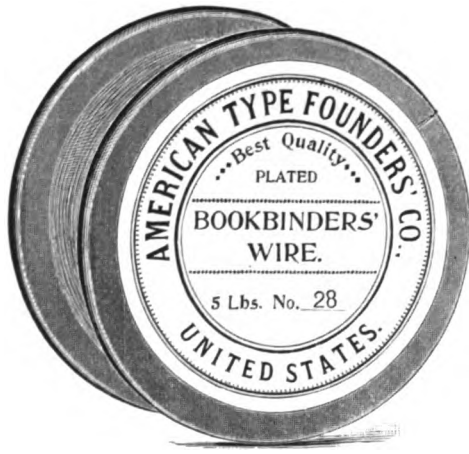

The wire we carry in stock is the very best procurable, and it will be sold at prices as favorable as any prices obtainable elsewhere for the same grade of quality.

There is no economy in poor wire, as the trouble it occasions much more than offsets any saving in the first cost.

The standard list prices are printed on page 951. These are by no means as low as the net prices we quote to regular users. The prices of wire are subject to frequent changes on account of the fluctuations in the cost of metals.

The table below will save users of wire a great deal of time, and enable them to estimate accurately the cost of wire in each job and the amount necessary to order.

WIRE STAPLE TABLE: SHOWING NUMBER OF STAPLES TO ONE POUND OF WIRE.

To ascertain the number of staples to one pound of wire, measure *full length* of wire in staple, go to first column on left of table and pass down same until you reach the size that corresponds with staple measured; pass along to right until you reach size of wire used, shown by top row of figures. Example: If your staple measures 1 1/4 inches, and the size of wire is No. 28, there are 11,940 staples to one pound, as shown in table.

Length of Wire in Staple.	18	19	20	21	22	23	24	25	26	27	28	29	30
1/2 inch	4104	5394	7408	8856	11594	14544	17142	22640	28236	31578	35820	40678	47088
3/8 inch	3283	4315	5926	7084	9275	11635	13713	18112	22588	25262	28666	32542	37646
5/8 inch	2736	3596	4938	5904	7729	9696	11428	15093	18824	21052	23880	27118	31372
7/8 inch	2345	3082	4233	5060	6625	8310	9795	12937	16134	18044	20468	23244	26890
1 inch	2052	2697	3704	4428	5797	7272	8571	11320	14118	15780	17910	20339	23520
1 1/8 inch	1824	2397	3292	3936	5152	6464	7618	10062	12549	14034	15920	18079	20914
1 1/4 inch	1641	2157	2963	3542	4637	5817	6856	9056	11204	12631	14328	16271	18823
1 3/8 inch	1492	1961	2693	3220	4216	5288	6233	8232	10267	11482	13025	14792	17112
1 1/2 inch	1368	1798	2460	2952	3864	4848	5714	7546	9412	10526	11940	13559	15686
1 3/4 inch	1262	1650	2279	2724	3567	4475	5274	6966	8688	9716	11021	12516	14479
1 7/8 inch	1172	1541	2116	2530	3312	4155	4897	6468	8067	9022	10234	11622	13445
1 3/4 inch	1094	1438	1975	2391	3091	3878	4571	6037	7529	8420	9552	10847	12458
2 inch	1026	1348	1852	2214	2848	3636	4285	5660	7059	7894	8955	10169	11764
2 1/8 inch	965	1269	1743	2083	2728	3422	4033	5327	6643	7430	8428	9571	11072
2 1/4 inch	912	1198	1646	1968	2576	3232	3800	5031	6274	7017	7960	9039	10457
2 3/8 inch	864	1135	1559	1864	2440	3061	3608	4766	5944	6648	7541	8563	9906
2 1/2 inch	820	1078	1481	1771	2318	2908	3428	4528	5647	6315	7164	8135	9411
2 5/8 inch	781	1027	1411	1686	2208	2770	3295	4312	5378	6014	6822	7748	8963
2 3/4 inch	746	980	1346	1610	2108	2644	3116	4116	5133	5741	6512	7396	8556
2 7/8 inch	713	938	1288	1540	2016	2529	2981	3937	4910	5491	6229	7064	8184
3 inch	684	899	1234	1476	1932	2424	2857	3773	4706	5263	5970	6779	7843
3 1/8 inch	656	863	1185	1416	1855	2327	2742	3622	4517	5052	5731	6508	7529
3 1/4 inch	631	829	1139	1362	1783	2237	2637	3483	4344	4858	5510	6228	7239
3 3/8 inch	608	790	1097	1312	1717	2154	2539	3354	4183	4678	5306	6065	6971
3 1/2 inch	586	770	1058	1265	1656	2077	2448	3234	4033	4511	5117	5811	6722
No. of ft. in 1 lb.	171	224 1/2	308 1/2	369	483 1/2	606	714 1/2	943 1/2	1176 1/2	1315 1/2	1492 1/2	1664 1/2	1960 1/2

Table copyrighted by C. D. Blackhall, 1893. Published by permission.

TENNIS BOOK-SEWING MACHINE.

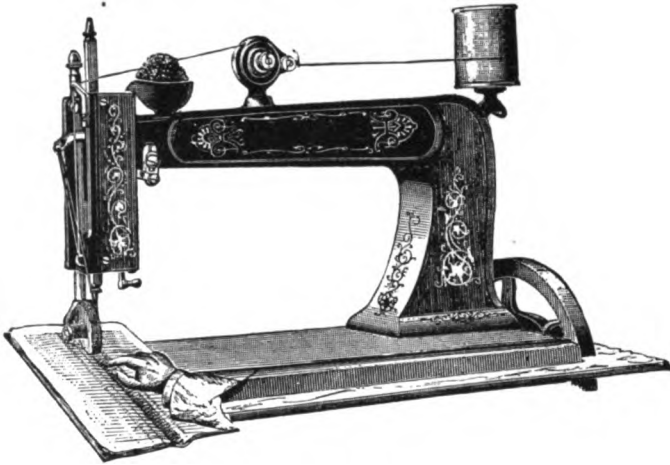

Designed for stitching blank books of every kind, and pamphlets and books not exceeding a thickness of three-eighths inch. Will sew through back or center, making stitches one-inch, half-inch, or quarter-inch long. Books sewed by this method are durable, and open perfectly. Sample work sent to us will be stitched and returned.

This machine is in use in almost every prominent blank-book factory in the United States.

In ordering steam power it is necessary to state diameter of shaft from which belt will be run to machine.

Shows Long Stitch.



Shows Short Stitch.



Shows Medium Stitch.

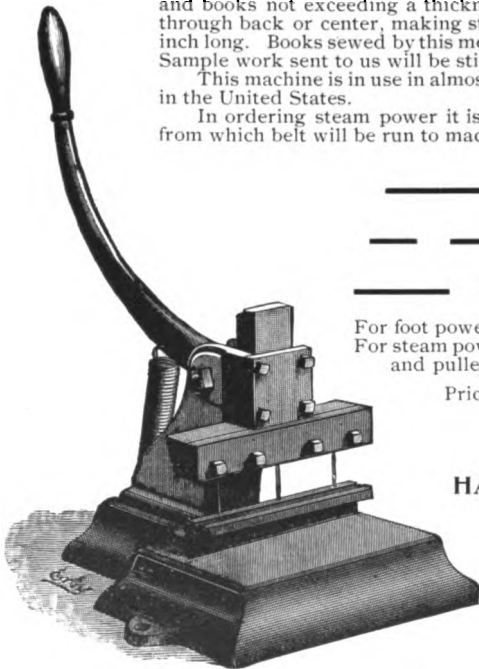

For foot power, with stand and table \$60 00

For steam power, with variable speed, stand
and pulleys, complete 70 00

Prices are strictly net f. o. b. factory.

HAND STABBING MACHINE.

For stabbing pamphlets, receipt books, etc., by hand or foot power. Built of iron, and made to fasten to a bench or table. The position of the needles can be easily and quickly changed, as they move laterally in a slot, and are held by set screws.

For hand power \$25 00
 For foot power 50 00
 Needles, per dozen 3 00

MONITOR COMBINATION PUNCHING AND ROUND-CORNER AND INDEXING MACHINE.

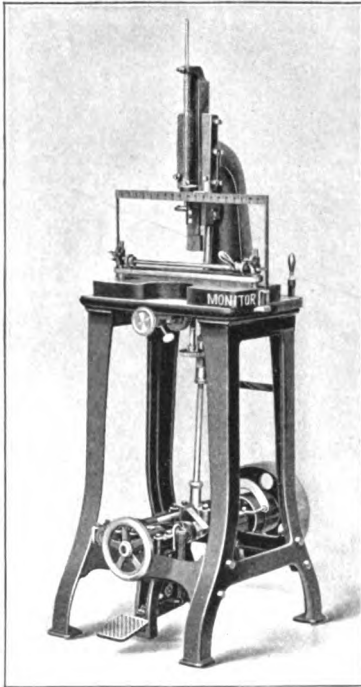

Complete, for Power, \$180.00.



Complete, for Foot Power, \$120.00.

A very desirable machine. By foot, it cuts easily through card or paper 1½ inch thick; by power, 3 inches. The table, besides having adjustable guides and a full-length clamp to hold the work during the cut, is movable from right to left, or *vice versa*, by means of a rack and gear operated by the hand wheel in front. A graduated scale and index above the table enables the operator to work quickly and with accuracy. The knives, Nos. 1, 2 and 3 (illustrated), or three of one No., are furnished with each complete machine.

By removing sliding table and index scale, and substituting a punch or round-corner cutter for the index knife, this machine is easily changed into a punching machine or round-corner cutting machine. In ordering punches and dies be guided by following diagram, and order by number or initial on diagram.

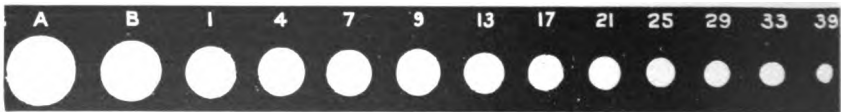
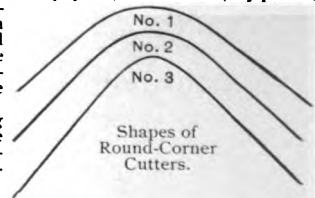

- For foot power, complete with sliding table and index scale, one index knife,
one punch and die, and three round-corner knives; weight, crated, 435 lbs. **\$120 00**
- For power, complete with same attachments as above; weight, crated, 550 lbs. **180 00**
- Foot Power Indexing Machine, with round or square knife **100 00**
- Extra punch and die, per set **2 50**
- Extra round-corner knives, each **1 50**
- Extra index knives, each **2 50**

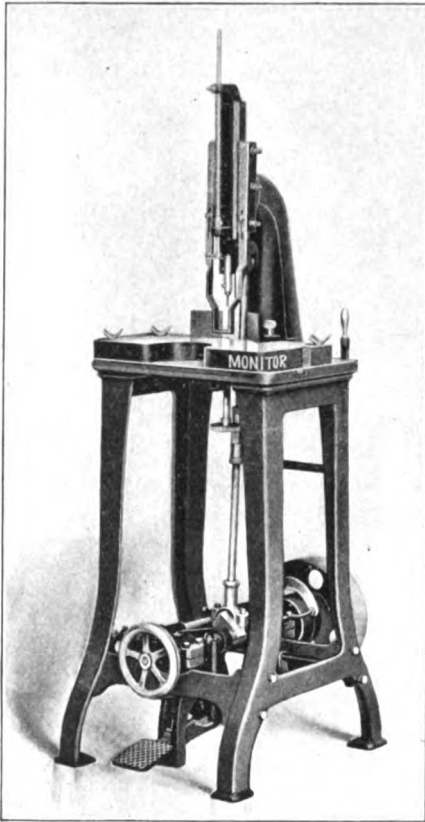

For Power.

MONITOR JOB BACKER.

This has ample strength and is accurately fitted. It is extra heavy and reinforced at the corners. The boxes are phosphor bronze, and the screw and jaw are of steel.

- No. 1 takes 17-inch book \$70 00
 - No. 1 takes 21-inch book 75 00
 - No. 2 takes 24-inch book, extra heavy . . 85 00
 - No. 3 takes 29-inch book, extra heavy . . 95 00
- Boxing extra.

SPECIAL NOTICE.— We are prepared to quote favorable prices for all kinds of bookbinders' machinery, new or second-hand. In writing for quotations time will be saved if the requirements of customers are very specifically stated.

MONITOR PUNCHING AND ROUND-CORNER CUTTING MACHINES.

Furnished for power or foot power. With foot power will cut easily through card or paper 1½ inches thick, and with power through card or paper 3 inches thick. The cutter block is furnished of either wood or composition metal which does not injure the knives, and is so set as to be readily adjusted or removed. The head is rigid, and there is no spring or deflection in the punch or cut.

Order punches by the initials and numbers on the diagram printed on opposite page.

Each machine ordered for round-corner cutting is furnished with one each of the three knives illustrated on opposite page, or three knives of any one size, if desired.

- Foot Power Round-Corner Machine, with three knives (shapes of knives illustrated on page 954) \$75 00
- Foot Power Punching Machine, with one punch and die 75 00
- Power Round-Corner or Punching Machine, heavier pattern, with extras as above, each 135 00
- Round-corner knives, each 1 50
- Punch and die, per set 2 50



THE PETIT FOOT-POWER EYELETTING MACHINE.

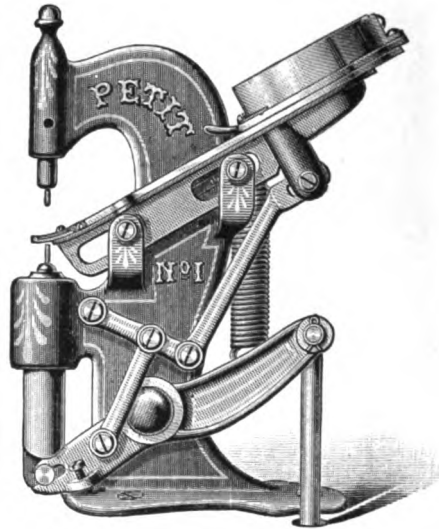

This is not recommended for the general work of printing offices and binderies, but is perfectly adapted to special work requiring eyelets not exceeding $\frac{3}{16}$ -inch inside, known as No. 1 "C. Z." It will take the smallest eyelet, $\frac{1}{16}$ -inch inside, known as "D. E." It is a perfect feeding machine, 12 inches high, 9 inches deep, weighs only 17 pounds, and is very easy to operate.

No. 1. The Petit, with one Roadway	\$30 00
Extra Roadways, each	12 00

EYELETS.

The largest eyelet used is "No. 3 Calendar," smallest is "D. E.," $\frac{1}{16}$ -inch inside. The eyelets in most common use are "No. 3 Calendar" and "No. 2 Skirt" (as illustrated). The prices of eyelets in large quantities vary from time to time, and special quotations will be given when required.

Smallest quantity sold 10,000 in one box, except No. 3 Calendar, which are put up in boxes of 5000. They are also packed in bulk cases containing 250,000 of any size.

No. 3 Calendar Eyelets, per box of 5000	\$3 75
No. 2 Skirt Eyelets, per box of 10,000	4 50

Special quotations for larger quantities.

Sizes of Eyelets.

The cuts show exact sizes of each eyelet when set in the material eye-letted.

The heavy figures under cuts indicate the size of punch and die to be used with eye-lets.

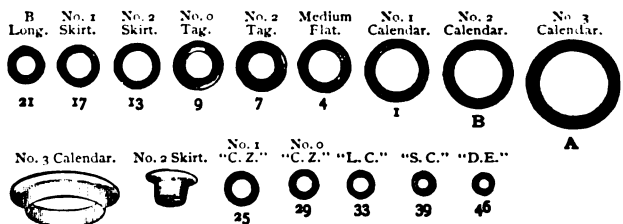

SELF-FEED FOOT POWER EYELETTING MACHINES.

With Removable Roadways.

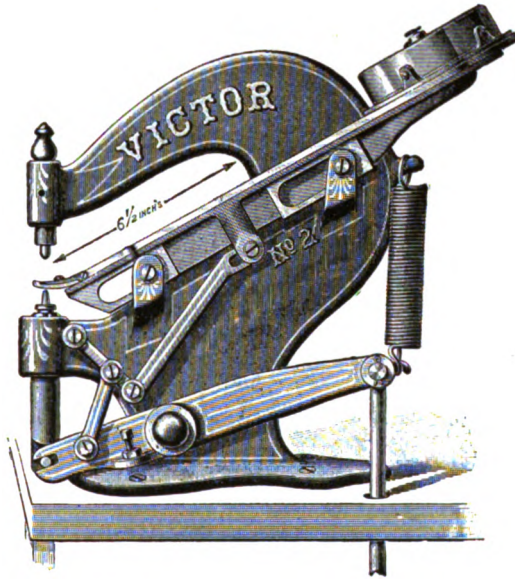

THE VICTOR.

Has a reach from eyelet set to back of arm of 6½ inches, and will set an eyelet in the centre of a square 13 × 13 inches. Will set eyelets in paper, metal, leather, cloth, etc.

The eyelet roadway or feed channel is made to feed but one size eyelet; if other size eyelets are used on machine, an extra roadway is necessary. When ordering machine, specify by name the eyelet for which machine is to be fitted. If extra roadways are wanted, be particular to state the size of eyelet to be used. It takes only a few moments to change one roadway for another on machine.

The Victor is easy to operate, weighs 30 pounds, is 14 inches high, 15 inches deep, and is a perfect working machine and very durable.

No. 2. The Victor, with one roadway	\$40 00
Extra roadways, each	14 00
Power attachments, extra	40 00

In ordering, send samples of eyelets to be used, as the roadway will feed only one size of eyelet. An extra roadway is required for each size of eyelet.

THE ROYAL.

Differs from the No. 2 Victor in the reach only, which is 9 inches, setting eyelets in a square 18 × 18 inches.

It weighs 45 pounds, is 15 inches high, 16 inches deep, and is a perfect working and very durable machine.

No. 3. The Royal, with one roadway	\$45 00
Extra roadways, each	16 00
Power attachments, extra	40 00

In ordering, send sample of eyelet to be used, as the roadway will feed only one size of eyelet. An extra roadway is required for each size of eyelet.

No. 4 PUNCHING AND HAND EYELETTING MACHINE.

Nos.

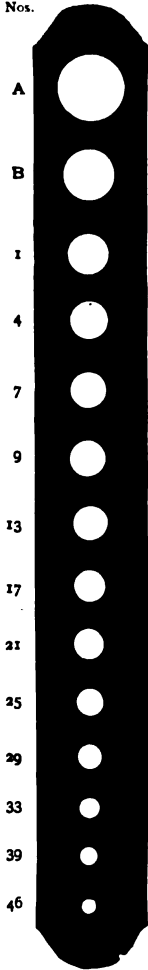

Can be used for Eyeletting by Hand by Substituting Punches for Eyelet Sets.

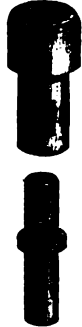

Punch and Die.

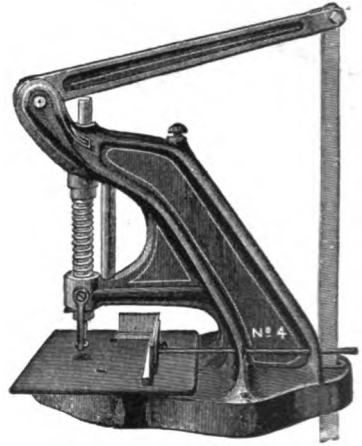

This is the proper machine to use with eyeletting machines shown on following pages. Except on cloth, good work cannot be done unless the hole is punched out *clean* before eyeletting. The No. 4 Machine will do work up to $\frac{3}{8}$ -inch diameter (No. 3 Calendar Eyelet) and has a reach of 6½ inches back of plunger, and an adjustable gauge for all kinds of work.

By removing the punch and die and substituting an eyelet set, this machine may be used for eyeletting by hand feed, and will do perfect work.

No. 4 Punching Machine, with Treadle, and one Punch and Die	\$20 00
Extra Punch and Die, per pair	2 50
Eyelet Set, per pair	2 50

COMBINED EYELET PUNCH AND SET.

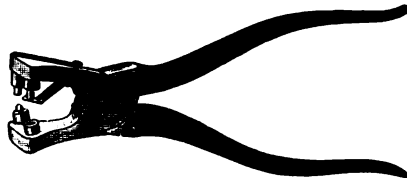

An indispensable tool in the printing office. Punches the hole and sets the eyelet. Takes only one size of eyelet (No. 2 Skirt).

Price, complete	\$2 25
Eyelets, per box of 1000	0 50

Sizes of punches and dies correspond with eyelets made. Order by number.

BOOKBINDERS' LETTERING PALLET.

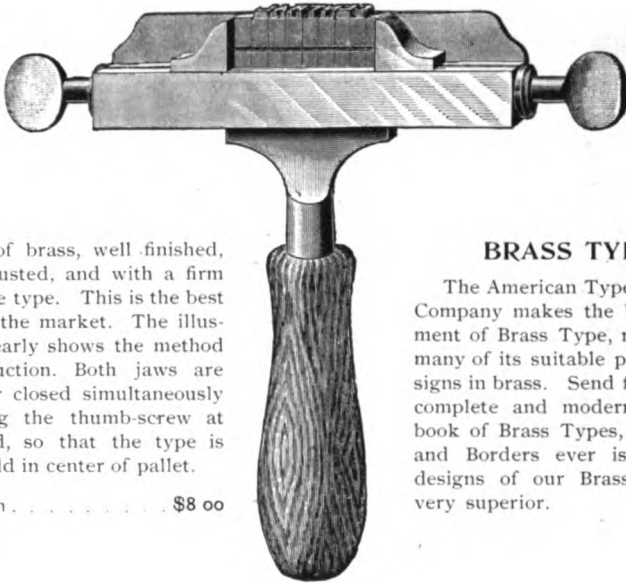

Made of brass, well finished, easily adjusted, and with a firm grip on the type. This is the best Pallet on the market. The illustration clearly shows the method of construction. Both jaws are opened or closed simultaneously by turning the thumb-screw at either end, so that the type is always held in center of pallet.

Price, each \$8 00

BRASS TYPE.

The American Type Founders' Company makes the best assortment of Brass Type, reproducing many of its suitable patented designs in brass. Send for the most complete and modern specimen book of Brass Types, Ornaments and Borders ever issued. The designs of our Brass Type are very superior.

METAL TYPE FOR BOOKBINDERS.

The Copper Alloy Type made by the American Type Founders' Company is of extra hardness, and better suited for bookbinding purposes than type made of ordinary type metal. All the type shown in the specimen books of the American Type Founders' Company is made of its famous Copper Alloy Metal.

BOOKBINDERS' CABINETS.

Made of hard wood, cherry finish, with bronzed pulls on each case. The cases are made in exactly the same style as printers' cases. These cabinets occupy a space of 20x20 inches, and may be put on or under a bench. "A place for everything and everything in its place" is a rule bookbinders should live up to, and these cabinets enable them to do so.



Cabinets with 6 cases \$ 8 00
 Cabinets with 10 cases 12 00
 Cabinets with 15 cases 16 50

BOOKBINDERS' CASE.

Half Cap Case, 16x16 1/4 inches, without bronze pull, each \$0 60



Case used in Bookbinders' Cabinet.

HAND EMBOSsing PRESS.

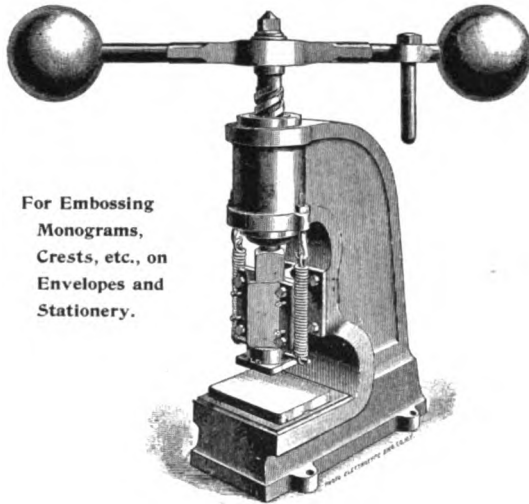

For Embossing
Monograms,
Crests, etc., on
Envelopes and
Stationery.

Embossed work on envelopes, note paper, menus, and other fine stationery, is the most stylish form of printing. The process is simple. Dies cost from \$1.00 to \$5.00, according to elaboration of design. Dies are made of steel. The counter is usually made of bristol board, thin rubber cloth and thin paper, and is fastened to bed-plate with glue or gum arabic. The inks are made from dry colors, mixed with white damar varnish. The ink is smeared over the die, and the face of the die is cleaned of ink, and polished by rubbing on paper. Bronzed effects are obtained by embossing with varnish instead of ink, and dusting on the bronze; superfluous bronze is taken off by dusting with a brush. Any printer can do this work, and thus add a lucrative department to the business.

This press is the best made, and is used by all the leading houses.

Large Press, with one Die-Box and Counter	\$75 00
Small Press, with one Die-Box and Counter	60 00
Extra Die-Boxes, each	4 00
Extra Counters, each	3 00

Weight of large press is 335 lbs.; of small press, 190 lbs. Boxing, \$1.50 net.

Those who have use for one press are advised to purchase the large size, as the other will only take small dies. Largest die taken on large press, 5 · 4 inches; on small press, 4 · 3 inches.

FAST GOLD LEAF LETTERING AND STAMPING PRESSES.

Made in two styles. No. 1, illustrated here, is the best press of its kind for small stamping or embossing. Size of platen, 12 · 12 inches; size of head, 11 · 11 inches. The wheel at top carries the screw that raises or lowers the head, and the set screw at front binds it firmly. Can be supplied with 19½ or 26 inches between uprights.

Three stamp-holders, varying sizes; one large chase, one large and one small plate for electros and brass work, one atmospheric gas heater, set of band holders, and assortment of steel fillers for chase, go with each machine.

The No. 2 press, for gas, gasoline or steam, is especially recommended for printing badges. In this press the bed does not slide, and the platen is raised or lowered by screws set in the side frames. Size of head, 12 · 12 inches; size of platen, 13½ · 13½ inches. Takes work 14 inches wide and any length.

The head will allow a change of six inches in thickness. One type-holder with chase, two plates for electros, one set of fillers, and an atmospheric gas heater go with each machine.

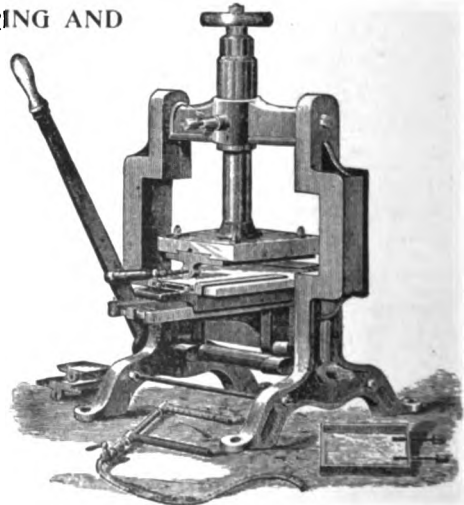

No. 1 Stamping and Embossing Press, for Steam, Gas or Gasoline.

No. 1, complete, as described . . . \$150 00 | No. 2, complete, as described . . . \$75 00

Catalogue of Embossing Dies sent on receipt of 25 cents.

CARVER & SWIFT POWER STAMPING PRESS.

Prints and Embosses at One Impression.

The die is held in a double-jawed chuck on bed of press; immediately over the bed in its vertical position is a counter-block, driven up and down by connection with a powerful toggle. The counter is made in the same way as on the hand-stamping press, described on opposite page. The ink fountain is at rear of press, having a continuously revolving roller which serves to keep the ink "alive." An oscillating arm carries the distributor, which supplies ink to the die on its backward and forward motion. As the die travels forward, it passes under the wiping plate, around which a web of manilla wiping paper is carried. The contact with the wiping paper removes all ink from the surface of the die, leaving it only in the engraved parts. The bed travels to a vertical position, where it is automatically locked and held for the impression. The sheets are fed to gauge pins as on a job press, and thus at one feeding beautiful results are produced.

Perfect register is insured for burnishing bronzed work by the fact that the machine is provided with an automatic lock, which holds the bed in position while the impression is made.

Any properly engraved die from one line, or monogram, up to commercial dies measuring three and a half inches by eight inches, can be stamped.

The speed is a matter most generally determined by the operator, and while a general average would be about nine thousand impressions per day, the machine has a record of seventeen thousand in less than eleven hours.

The machine weighs about four thousand pounds and occupies a floor space of three feet nine inches by four feet six inches, exclusive of projecting feed boards.

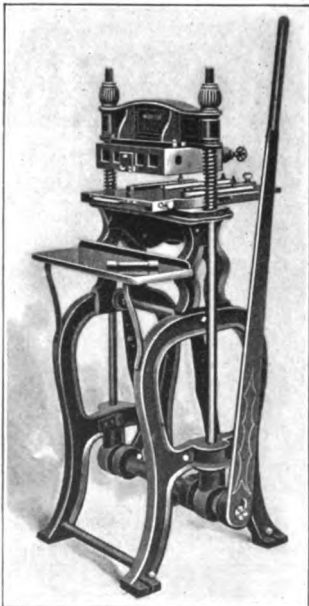
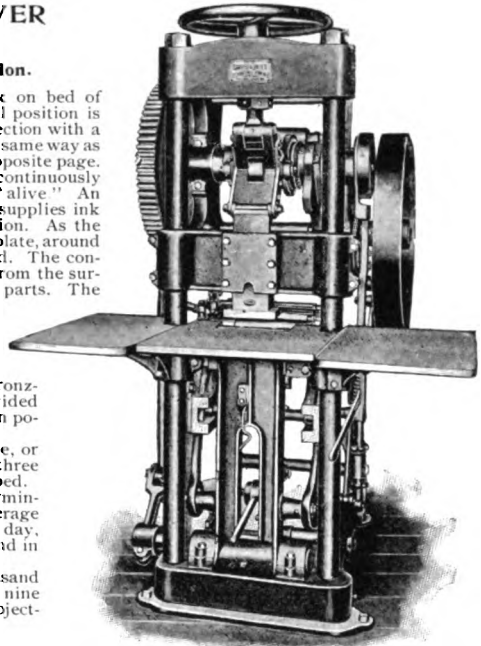

Monitor Lever Embosser No. 2.

Stamping press, complete, with counter-shaft and hangers with friction clutch, wide-face pulley, and three-step cone pulley, three-step cone pulley for main shaft, two large and two small ink fountains, three counterblocks, one set each of plush and composition rollers, f. o. b. factory \$1650 00

MONITOR LEVER EMBOSSE No. 2.

With Steam or Gas Head.

Size of head, 9x13 inches. Size between uprights, 17½ inches. Can be used for all ordinary work in a bindery. Powerful leverage; working parts of best steel.

No. 2 Monitor Lever Embosser; size of head, 9x13 inches \$175 00

OTHER EMBOSHING PRESSES.

Particulars on Application.

No. 1 Monitor Foot Power Embossing Press; size of head, 7x11 inches \$110 00
 No. 3 Monitor Power Embossing Press; size of head, 11x15 inches 450 00
 No. 5 Monitor Power Embossing and Smashing Press; size of head, 18x21 inches 900 00

FRANKLIN HAND PERFORATOR.

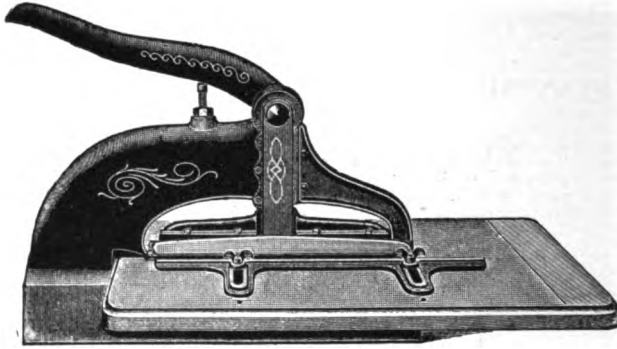

Perforates ten inches, and is provided with gauges on both sides, so that the sheets may be turned and fed in again, making a continuous perforated line of twenty inches. The pins make round holes, like the perforations on a sheet of postage stamps. Fifteen holes to an inch.

Hand Perforator, 10 inches \$25 00

STIMPSON LEVER AND TREADLE ROUND-HOLE PERFORATOR.

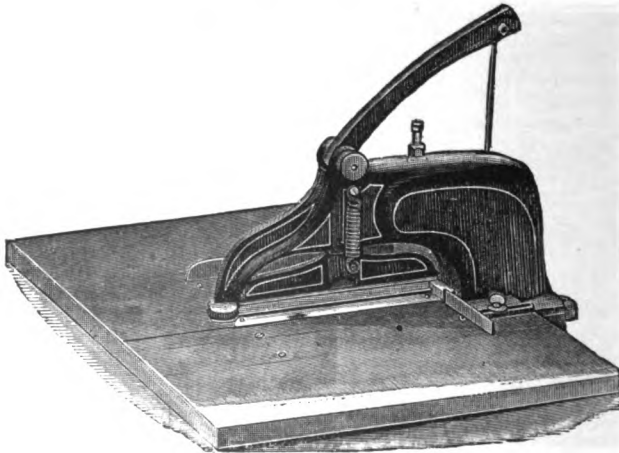

In every respect a perfect and superior machine, in keeping with the reputation of the makers, and well worth the price asked.

Perforates 10 inches with treadle \$40 00

TREADLE PERFORATORS.

We list on this page two grades, each of which accomplishes the same work, the difference in prices indicating differences in workmanship and durability.

STANDARD GRADE TREADLE PERFORATOR.



Round-hole perforators, with removable pins, with accurate gauges, and the best procurable at the price, meeting the requirements of the average binding and printing office.

Standard Grade, perforates 20 inches, with treadle	\$ 75 00
Standard Grade, perforates 24 inches, with treadle	100 00
Standard Grade, perforates 28 inches, with treadle	125 00
Standard Grade, perforates 24 inches, for power	150 00
Standard Grade, perforates 28 inches, for power	175 00

GEM TREADLE PERFORATOR.

Gem, perforates 15 inches	\$40 00
Gem, perforates 20 inches	50 00
Gem, perforates 24 inches	60 00
Gem, perforates 28 inches	70 00



STIMPSON ROUND-HOLE PERFORATING MACHINES.

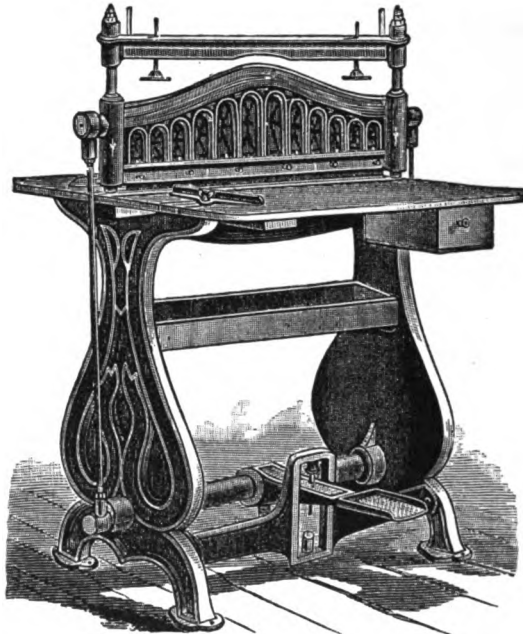

This illustrates the 25, 30 and 36-inch Stimpson Perforators.

This is conceded to be the best line of perforators made in the world. Nothing has been neglected in the way of good material, good workmanship and accurate adjustments, and consequently they do the best work, and wear longer than any other perforators. For those who keep a perforator in constant use an investment in one of these perforators will prove the most profitable, and will be found to keep up a perfect standard of work for many years. Power may be applied to any size.

These perforators are made to make two sizes of perforations—No. 60 gauge (15 holes to an inch), and No. 65 gauge (18 holes to an inch). The No. 65 gauge is the most satisfactory for checks, bonds, drafts, stubs and labels.



No. 65 Gauge.



No. 60 Gauge.

	No. 60 Gauge.	No. 65 Gauge.
20-inch machine, on substantial box-frame iron pedestal . . .	\$150 00	\$160 00
25-inch machine, as per illustration	225 00	240 00
30-inch machine	300 00	325 00
36-inch machine	400 00	435 00

POWER ATTACHMENT for any of these machines, **\$125 00 extra.**

PEERLESS ROTARY PERFORATOR.

For Power.

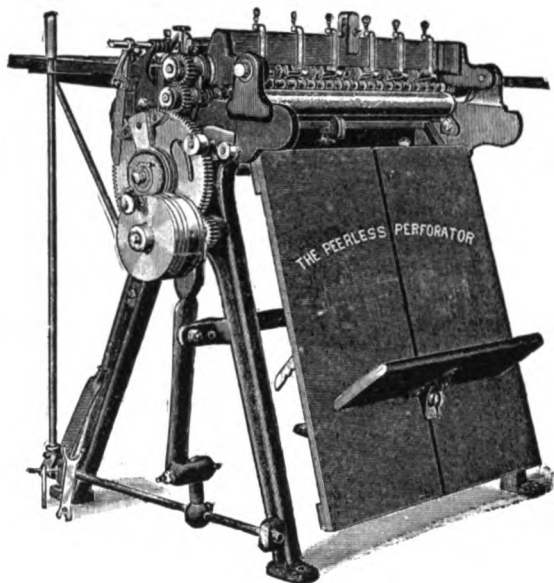

A thoroughly-tested, successful rotary power perforator, cutting six or less separate lines of perforations at a time, and provided with adjustable striking cams for skipping the perforations any distance, from the usual lengths of stubs to very short spaces. When the skip is as short as half an inch special fitting must be done, at a small extra expense. Accurate gauges, easily changed, are provided. The sheets deliver themselves after perforation into a lay-box, taking up very little room, and stacking the sheets regularly. Sheets are fed to machine as into a ruling machine.

Not the least remarkable feature is the form of the perforations, which are *cut out* of the paper cleanly, without any trace of burr, in oblong holes instead of the usual round holes. The machine will perforate a single sheet of manifold paper (without the usual aid of a thicker sheet) or heaviest manilla paper.

The oblong perforations are the distinctive feature of this machine. There is no displacement or swell of the paper along the perforated lines, and the clean cut of every hole, the absence of all burr, and the ease with which the paper separates through the perforations, commend the machine to all who aim to do the best grade of work.

This perforator is in use in a majority of the first-class manufacturing stationers and printing houses, and is built thoroughly well. All parts are interchangeable.

Price, with six pairs of cutters and one scoring cutter and die, f. o. b. Chicago,
net \$350 00

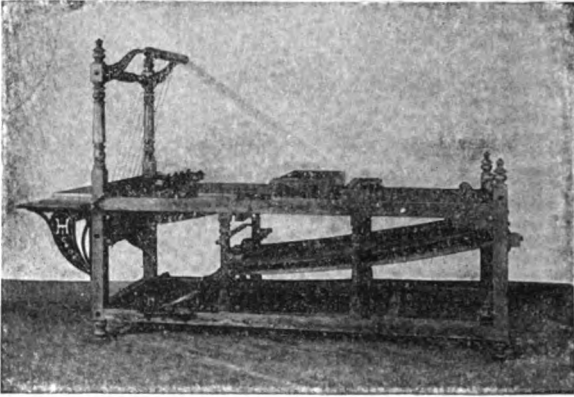
STYLE 2-B HICKOK HAND STRIKER RULING MACHINE.

Designed for small shops, where ruling is not done very rapidly, and where, therefore, the ink has time to dry (though the carrier is short) after the paper has passed under the pens and before it drops into the receiving box at feeder's feet. So far as material and workmanship are concerned, there is nothing better made than Style 2-B. The difference between it and the higher-priced rulers is simply in the number of parts used. Striking is accomplished on this machine exactly as it is on the Style 1-A ruling machine. Paper drops into receiving box.

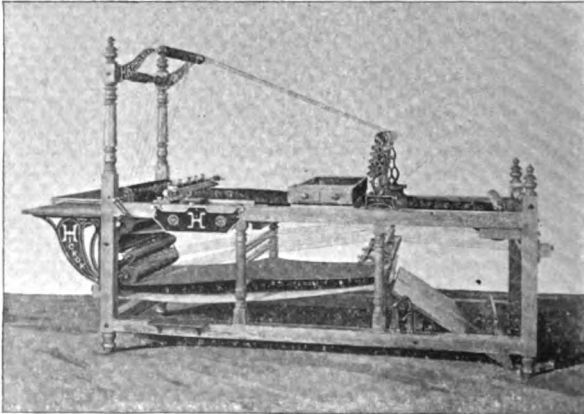
STYLE 1-A HICKOK HAND STRIKER RULING MACHINE.

STYLE 1-A Ruling Machine is for use in shops where there is considerable faint or cross ruling, thus economizing the time of automatic strikers used in the same shop. It may also be used in small-sized binderies, where there is not sufficient work for an automatic striker machine. The operator turns the hand crank with the left hand, thus operating the machine by hand, while with the right hand the pen-beam is tilted up and down, doing hand striking. Power may be applied, and steam attachments are furnished to order at an extra charge. Style 1-A is as perfectly built in every part as the most expensive automatic striker ruling machine. The difference in construction is simply leaving off the striker parts and some other necessary pieces required on an automatic striker machine.

For prices, see next page.

STYLE 1 SINGLE BEAM AUTOMATIC STRIKER RULING MACHINE.

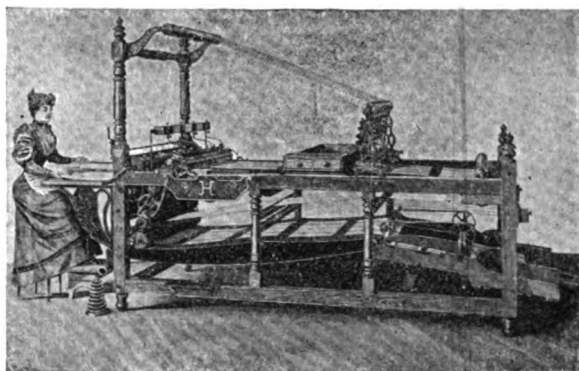

STYLE 1 is used for faint or cross-lining when the striker is not operated, and also for down ruling from cross or head lines when the automatic striker is used for the purpose of leaving unrulled head spaces by automatically raising the pens from the paper and allowing them again to descend upon the paper, the pens beginning to rule immediately upon touching the paper at a cross head line, and again being automatically raised from the paper and lowered upon the paper again successively at distances prearranged by the positions of the cams, which are adjusted by the operator, who sets them in the circular-revolving cam-head. This machine is for use on all classes of job ruling.

The illustration shows the combined lay-boy and receiver—a device for receiving the paper (after it is ruled) in the lower portion of the machine. Gears are used in setting the striker—friction devices being avoided because gears are more positive in the correct delivery of both speed and power.

PRICES OF RULING MACHINES.

2-B, with new Monitor standards, patent beam, patent pen rest, two 32-inch and two 26½-inch clamps, arranged to deliver paper in receiving box at feeder's end of machine (steam fixtures not included—\$15 extra, if required) \$190 00

WIDTHS	{	Between Rails:	38 inches.	42 inches.	44 inches.	48 inches.	54 inches.
		Cloth Width:	32 inches.	36 inches.	38 inches.	42 inches.	48 inches.

STYLE 1-A, with Improved Receiving Box	\$235 00	\$275 00	\$285 00	\$305 00	\$335 00
With Lay-boy and Receiver	252 00	297 00	307 00	327 00	357 00
STYLE 1, with Receiving Box	410 00	450 00	460 00	480 00	510 00
With Lay-boy and Receiver	427 00	472 00	482 00	502 00	532 00

RULING PENS ON POINT SYSTEM.

Made to adjust with point system of type bodies of the American Type Founders' Co. Length of bars, 4¼ inches; six bars in a set. The number of pens on a bar can be calculated by any one familiar with point system of type bodies. Faint-line pens sold only in sets.

Faint-Line Pens, in bars (combs), from 7 point to 36 point, each pen	\$0 01 ½
Regular Down-Line Pens (Striker Pens), singles, and No. 9 double, each pen	0 02
Regular Down-Line Pens, triples, each pen	0 02 ½
Extra Long Down-Line Pens (Shanghai), singles, doubles, and triples, each pen	0 03
Extension Pens, soldered on brass, singles, doubles, and triples, each pen	0 03 ¾
Extension Pens, soldered on tin, singles, doubles, and triples, each pen	0 02 ½

STANDING PRESSES.

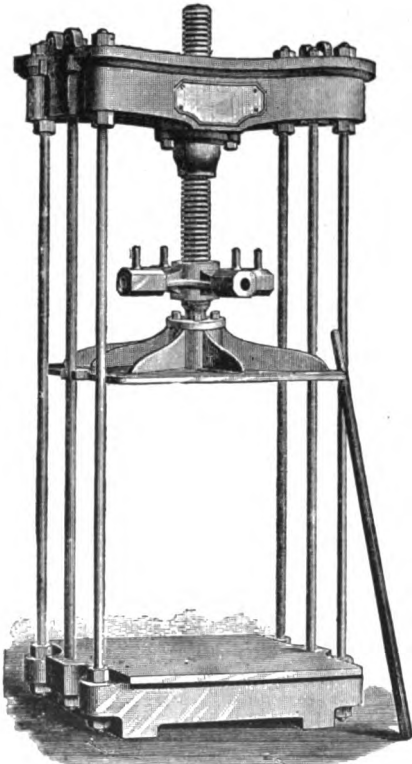

Illustrates Standing Presses Nos. 5 and 6, operated with spider and lever.

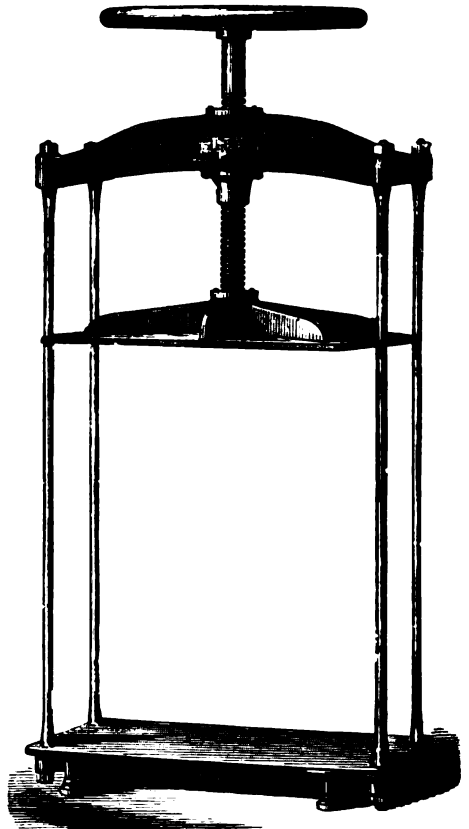

Illustrates Standing Presses, Nos. 2, 3 and 4, with hand wheel at top. No. 3 is also furnished with spider and lever.

These presses are very strong throughout—in top, base and platen.

No. 2 has four rods, and opens seven inches between bed and platen.

No. 3 has four rods, and opens thirty-seven inches.

No. 4 has four rods, and opens thirty-seven inches.

The Nos. 5 and 6 sizes have six wrought iron rods $1\frac{1}{4}$ inches in diameter. The boxes for main screw are phosphor bronze. The No. 5 opens forty-six inches, and No. 6 opens forty-eight inches. The screw is of $3\frac{1}{4}$ -inch steel, and is made all in one piece.

No. 2.—Size 10 × 16, operated by hand wheel at top, as shown in cut	\$25 00
No. 3.—Size 16 × 24, operated by a spider and lever	60 00
No. 4.—Size 16 × 24, operated by hand wheel at top	50 00
No. 5.—Size 20 × 28½, operated by a spider and lever, as shown in cut	110 00
No. 6.—Size 21 × 29, operated by a spider and lever	130 00

Boxing extra.

BRASS-BOUND PRESS BOARDS.

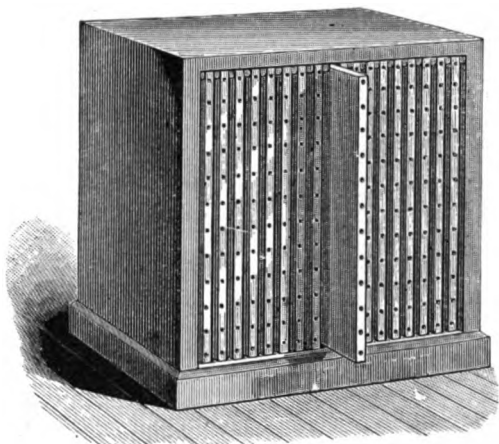

Made of seasoned, kiln-dried cherry, bound with hard brass, with folded corners.
 16×24 inches, each \$2 75 Case to hold 18 boards \$5 00
 Other sizes made to order. Special quotations given on large orders.

BOOKBINDERS' PRESS BOARDS.

Made from seasoned cherry, with cleated ends, and all guaranteed first-class, at the following prices, each :

6×10½ inches \$0 20	12×16 inches \$0 60	22×28 inches \$1 30
8×10½ inches 0 25	12×18 inches 0 70	24×30 inches 1 35
8×12 inches 0 30	13×20 inches 0 75	24×32 inches 1 45
10×13 inches 0 35	15×20 inches 0 80	26×40 inches 2 80
11×14 inches 0 45	16×24 inches 0 95	30×36 inches 3 25
10×16 inches 0 55	20×24 inches 1 05	36×44 inches 4 50

Other sizes made to order at proportionate prices. Special quotations given on large orders.

END-WOOD CUTTING BOARDS.

Made of end-wood, kiln-dried maple, any size desired. Each piece is grooved on all sides, and spliced and glued to the adjoining pieces, the result being the most durable and perfect cutting board which can be made.

Price, per square inch, face measure \$0 02½

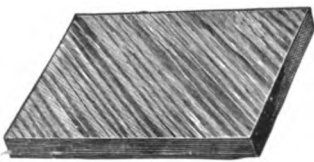
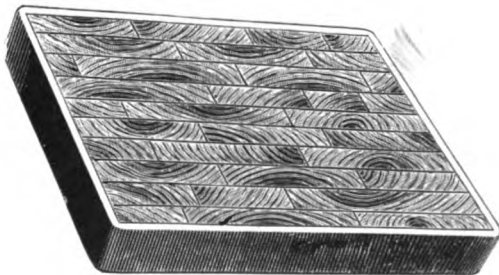

DIAGONAL GRAIN CUTTING BOARDS.

Made of kiln-dried maple. The diagonal grain blocks are the best procurable for this purpose.

8×12 Board, diagonal grain, per pair	\$1 75
8×12 Board, straight grain, per pair	1 20
Larger sizes, straight grain, per square foot	0 90
Larger sizes, diagonal grain, per square foot	1 25

UNION TABLETING APPARATUS.

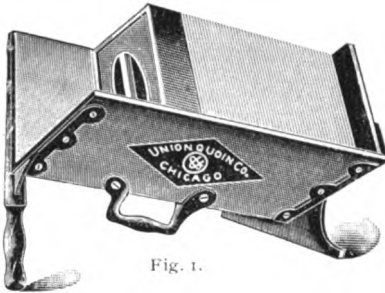

Fig. 1.

In this apparatus paper is held for padding without the use of screws or clamps. The trough (Fig. 1) is V-shaped, and is held at an angle which holds the paper snugly against the sides and the iron base-plate, which forms the bottom of the trough when it is tilted up. The paper in the trough is held under pressure by a heavy iron weight or brick; the trough is tilted up, and is lifted away, leaving the iron base-plate, paper and iron brick as in Fig. 2. The advantage this method has over the

tablet presses using clamps is that, by buying extra base-plates and iron bricks, an unlimited number of piles of paper may be put up without waiting for the drying of the cement; thus the capacity of this apparatus surpasses that of other apparatus used for a like purpose, and is equally as well adapted for use in both large and small establishments.

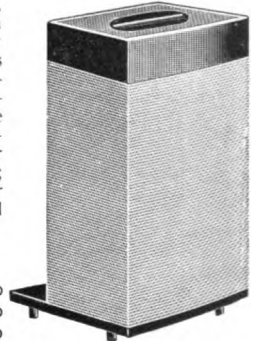
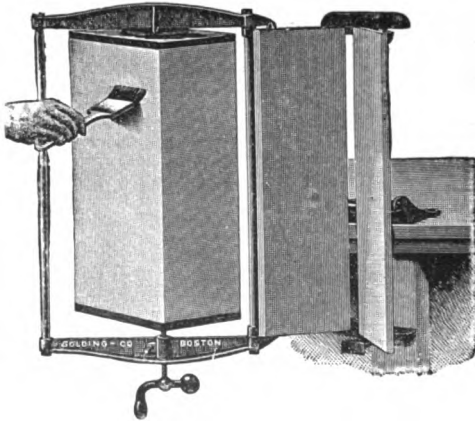

Fig. 2.

- Complete, with trough, base-plate and hollow iron brick, size 8½×8½×18 inches; capacity, 6000 sheets . . . \$7 50
- Extra iron bricks, hollow, each 2 00
- Extra iron bricks, solid, each 3 00
- Extra iron base-plates, each 0 75



No. 2 Golding Tablet Press filled with paper and cement being applied, in a perpendicular position.

**GOLDING
TABLET PRESS.**

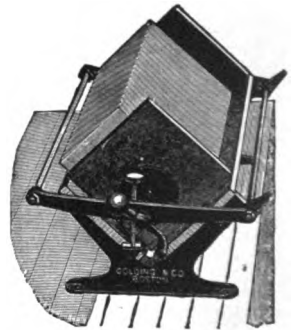

No. 1 Tablet Press on bench, filled with paper.

The paper is put in the V-shaped trough between boards, and, after sufficient pressure has been applied by the screw in the end of a hinged clamping frame, the latter is swung over, exposing the underside of the paper for cementing. Pads from 2×2 inches up to full capacity of the press may be blocked. The No. 2 press has a hinged bracket by which it is screwed to a bench, and which permits the paper to be held in a perpendicular position after clamping.

- No. 1, will hold 2000 sheets, any size up to 6×12 inches \$6 00
- No. 2, will hold 5000 sheets, any size up to 8×16 inches 12 00

BINGHAM & RUNGE LIQUID PADDING GLUE.

Made in Red, Purple, Green and Colorless.

The Bingham & Runge Padding Glue was the first put on the market, and it has always maintained its reputation. The best materials are used in its composition, and on this account it does not get rancid. A quart will cement about 100,000 sheets of note size.

Half-Pints	\$0 35	Quarts	\$1 00
Pints	0 60	Gallons	3 75

LIQUID CEMENT BRUSH.

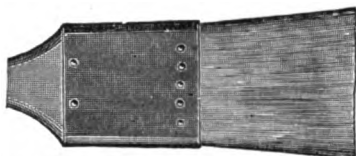

Made of French bristles, flat and double thick.

1 inch	\$0 30	2 inch	\$0 55
1½ inch	0 40	3½ inch	0 75



BINGHAM & RUNGE HERCULES ELASTIC PADDING GLUE.

An elastic, tough, quick-drying preparation, which is applied hot after melting in an ordinary glue pot, and, while entailing more labor, gives better results than the liquid glue. Does not adhere to the edges of sheets as they are removed from the pad, thus preventing tearing of pages in invoice and letter copying books. The color is bright red. Put up in pails, with directions for use on each.

5 pounds in pails . . . \$1 50 : 10 pounds in pails . . . \$3 00



PAPER COUNTER.

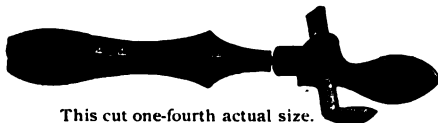

This cut one-fourth actual size.

To make ready for use in pad work, count out number of sheets wanted by hand, on top of which place the plate, then draw the stab up firmly against the paper. The screw in handle holds the stab in place. To operate, place plate on top of lot to be counted and push stab into paper, bearing down at same time.

Price \$0 75

GLUE POT.



1 quart, each \$0 90
2 quarts, each 1 20

TABLET KNIFE.



Made specially for separating pads; extra thin and strong.

Price \$0 50

FOR MAILING DEPARTMENT.

THE HORTON MAILER.

Patented
May 11, 1894.



This is the best label-pasting mailer. It is quicker and more exact, because all its movements are positive. It is so simple that it can be worked rapidly and efficiently by the inexpert, while experts have addressed with it at the rate of 170 per minute. It is operated, as illustrated, by one hand, leaving the other entirely free to manipulate the papers or wrappers.

It guides and thoroughly pastes the slip, scrapes off all surplus paste, and sticks the label cleanly and firmly. The knives are thin and adjustable, with two cutting surfaces, and can be easily sharpened. The arrangements for adjusting knives with each other and regulating tension of knives are very exact.

It is very strongly made, and is the most durable of mailers.

A TESTIMONIAL OF 1897.

The Ladies' Home Journal, Philadelphia; circulation, 690,000: "We have placed it in the hands of four of our experienced mailers, each having been given sufficient time to get acquainted with it, so that we might have more than one opinion. They were all satisfied that the machine is an improvement on any they have used. The Horton Mailer cuts and pastes the slip on the *Journal* or wrapper more thoroughly than the machines we have been using. . . . We do not believe it has an equal on the market to-day."

A TESTIMONIAL OF 1898.

April 21, 1898:—"We printed 850,000 copies of the April number, and it is nearly exhausted already. We are now using your Mailer exclusively, and, although our operators were very much averse to the change at first, we don't think they could be induced to go back to the machines they were using previously. We have yet to hear of a single complaint of any kind, either in its construction of use. **We save the cost of a machine in knife sharpening alone in four months.**"
MAILING BUREAU, THE CURTIS PUBLISHING CO. (*Ladies' Home Journal*.)

TROUBLE VANQUISHED.

AMERICAN TYPE FOUNDERS' CO.:—"We wish to say that for convenience, speed and accuracy the "Horton Mailer" has no equal. We are delighted with it. While we had innumerable complaints before that papers did not reach their destination (owing, as we claim, to the defects in the old mailer) we are now untroubled in that regard, and we enjoy a feast like the peace of the mirrored lake bounded on all sides by the high mountains of the Adirondacks. The "Horton Mailer" is all right.
STANDARD PUBLISHING CO., Watertown, N. Y.

Price, with extra knives, paste strainer, screw driver and oiler, net \$20 00

The exact size is 12 inches long by 3 inches wide by 5 inches high, and the weight is $2\frac{3}{4}$ pounds.

THE ACME MAILER.

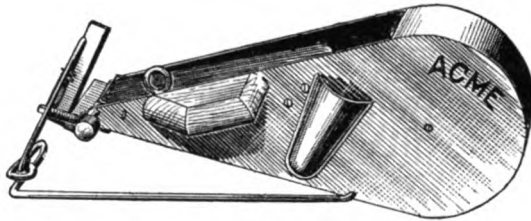

A good low-priced mailer, of which a great many are in use. It is built on the same lines as most of highest-priced mailers.
 Price, net \$15 00

RUKENBROD MAILER.

**New Style.
 All Metal.
 With Bell Attachment.**



This mailer prints direct on the paper or envelope, clearly, and as rapidly as paper can be put under the platen. It is the best mailer of its class. Each address is brought under the platen automatically, and bell quads may be used which will ring an alarm bell when the papers for any town are all addressed, whereupon the next town wrapper address is printed. Each mailer is provided with two platens, one for two-line address and one for three- and four-line addresses. No other mailer of its class will print a four-line address.
 All-metal mailer (as per illustration), net \$12 50

RUKENBROD MAILING GALLEY.



Wood rim, zinc bottom \$0 60
 Wood rim, brass bottom 0 85
 Galley reglet, per hundred 0 30
 Bell quadrats, per hundred 1 00

MUSTANG MAILER.

This mailer prints directly on the paper or envelope. The platen and its frame moves automatically, printing one address at a time. It will print three-line (8 Point) addresses.

The Mustang Mailer occupies a space of 37 inches in length and 4½ inches in width, and is made wholly of iron without springs or complications of any kind. Speed is regulated solely by the speed of operator in passing the papers to and from the mailer. The mail list is made up in galleys ten ems Pica wide on the inside.

Each galley holds seventy-five addresses. The weight of the machine is fifteen pounds, and of the galleys one pound.

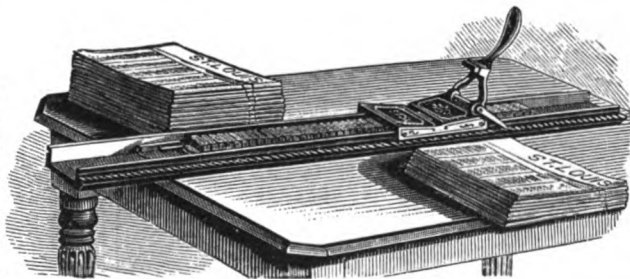

Price \$10 00

MUSTANG MAILING GALLEY.



Zinc bottom \$0 50
 Brass bottom 0 75

McFATRICH MAILING MACHINE.

Operated by treadle, leaving both hands free to handle the publication. Prints directly on the publication or the wrapper from type on galleys. The galley holding the addresses is moved one address at a time automatically. Speed from 2000 to 3000 per hour.

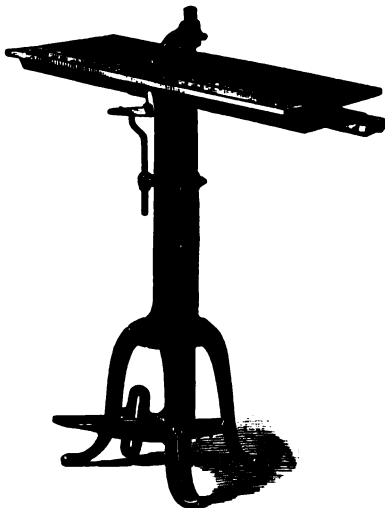

Machine for address 10 Picas wide . . .	\$25 00
Machine for address 14 Picas wide . . .	40 00
Galleys, 10 Picas wide, 29 inches long, each . . .	0 80
Galleys, 14 Picas wide, 30 inches long, each . . .	1 00
Wood Reglet, 10 point, per 100, 10 Picas .	0 25
Wood Reglet, 10 point, per 100, 14 Picas .	0 35
Metal Slugs, 10 point, per 100, 10 Picas .	1 00
Metal Slugs, 10 point, per 100, 14 Picas .	1 40
Bell Slugs, zinc, 10 point, per dozen, 10 Picas . . .	0 50
Bell Slugs, zinc, 10 point, per dozen, 14 Picas . . .	0 75

ECONOMY WRAPPER PASTER.

Patent applied for.

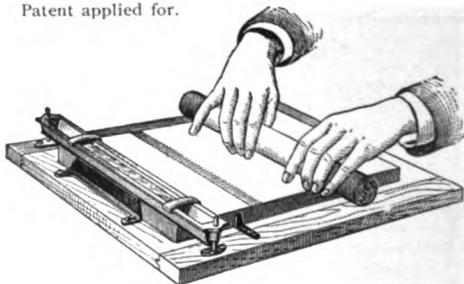

The paste fountain has a perforated bottom through which the paste reaches the top sheet of a pile, which may contain four hundred sheets. As the top sheet is drawn off, the next is pasted automatically and instantly, and so on. Wrappers are pasted as fast they can be drawn from the pile.

It saves all the time of "laying out" and applying paste with a brush, fifty per cent. in paste, and a great deal of space, as three or four hundred wrappers occupy no more table room than one, and you can wrap on top of the pile, as indicated in the cut.

A SAMPLE EXPERIENCE—A REMARKABLE SAVING.

CHICAGO GREAT WESTERN RAILWAY—PRINTING OFFICE.
CHARLES A. STICKNEY, SUPERINTENDENT PRINTING.

American Type Founders' Company:

ST. PAUL, MINN., April 20, 1897.

DEAR SIRS—In answer to your letter of April 13 about the "Economy Wrapper Paster": We have just finished wrapping an edition of fifteen thousand tariffs, 12x18 inches—28 pages. These tariffs were being wrapped at the rate of 250 per hour with a brush, while with the aid of your paster this was increased to 300 per hour. In every way I think it far ahead of a brush.

Yours truly,

CHARLES A. STICKNEY.

No. 10. For width of 10 inches or less, each . . .	\$4 00
No. 14. For width of 14 inches or less, each . . .	4 50
No. 16. For width of 16 inches or less, each . . .	5 00

MISCELLANEOUS SUPPLIES.

BOOKS FOR PRINTERS.

- THE AMERICAN PRINTER:** A Manual of Typography. By Thomas MacKellar, Ph.D. 12mo. 400 pp., cloth **\$2 00**
- THE HARMONIZER:** Showing a great variety of harmonious effects produced by printing colored ink on colored paper. By J. F. Earhart. Size, 5×7½ inches. 248 pages, cloth **3 50**
- HINTS ON IMPOSITION.** By L. B. Williams. Leather, 90 pp. **1 00**
- MANUAL OF PRINTING.** Vest-pocket size. 88 pp., leather **0 50**
- THE COLOR PRINTER:** Contains 625 different forms, and 1,625,000 impressions. An invaluable book. By J. F. Earhart. Size, 8¼×10½ inches. 227 pp., cloth . **10 00**
- PRESS WORK:** A Manual for Pressmen. By Wm. J. Kelly. Cloth, 99 pp. . . . **1 50**
- INLAND PRINTER ACCOUNT BOOK:** A New and Correct System of Keeping Accounts in Printing Offices. Size, 10½×14½ inches, flat opening, leather back and corners, cloth sides. Price, 400 pp., for 2000 jobs, **\$5 00**; 200 pp., for 1000 jobs **3 50**
- THE INLAND PRINTER:** A Monthly Magazine. Size, 9×12 inches. From 90 to 110 pp. per issue. Per copy, **20 cents**; per year **2 00**
- EMBOSSING MADE EASY:** Instructions for Embossing by cheap processes . . . **1 00**
- AMERICAN DICTIONARY OF PRINTING AND BOOKMAKING.** Size, 8½×11 inches. 592 pp., half morocco **12 00**
- NEWSPAPERDOM:** A Weekly Journal for Printers and Publishers. Per year . . **1 00**
- WHITE'S MULTI-COLOR CHARTS:** Show seventy-three different specimens of paper, each leaf printed in six colors. Size, 6×12 inches **1 00**
- CAMPBIE'S VEST-POCKET ESTIMATE BOOK.** 52 pages. Each, 50 cents; per dozen **5 00**

ENGRAVERS' TOOLS.



Six tools, sharpened for use, with handles, in box **\$2 50**

ENGRAVERS' WOOD.

Prepared to order, in the best manner. Prices are net. The minimum charge for Box-wood or Maple is twenty-five cents.

- Boxwood, per square inch **2 to 5 cents.**
 Maple, per square inch **1½ cents.**
 Soft-wood Poster Tint Blocks, 27¼×39¼ inches **\$1 25 each.**
 Soft-wood Poster Tint Blocks, per square foot **0 25**

REDUCING GLASS.



For ascertaining how far an engraving or drawing may be reduced with safety, and for ascertaining the effect which will be given by reductions of all kinds. In round metal frames with handle, three inches in diameter, each . . . **\$1 50**

MAGNIFYING GLASS.



Every careful printer needs a magnifying glass. This glass is three inches in diameter, in a strong metal frame, with handle, each **\$1 65**

THE SURGUY NEW HOT AIR STEREOTYPING APPARATUS.

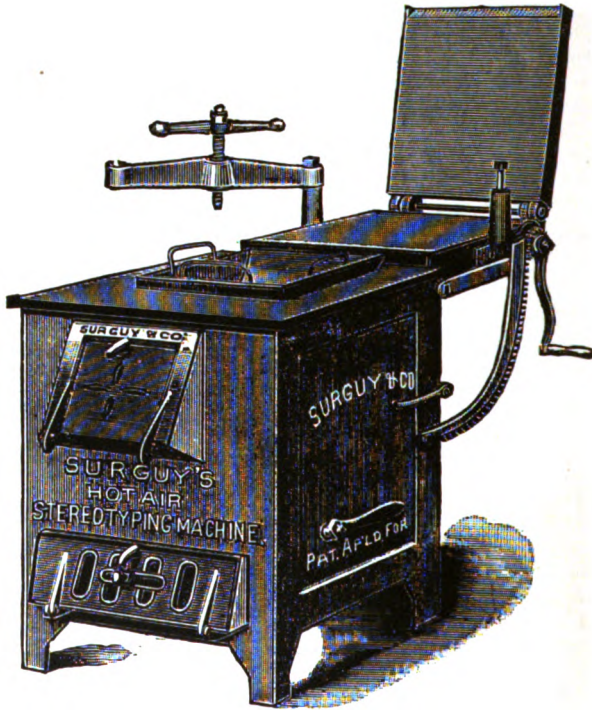

The furnace and casting box are combined. One fire of coal, wood or gas will melt metal and dry matrix simultaneously or separately if preferred, as metal pot is detachable. Each apparatus will make thin or type-high plates.

The 8½ x 14-inch apparatus will stereotype a form of 7½ x 10 inches. It is too small to use with wood or coal, and is fitted with a gasoline attachment, or gas may be used. The 12 x 20-inch apparatus will stereotype a form of 10 x 18 inches. The 18 x 26-inch apparatus will stereotype a form of 16 x 24 inches, taking in a standard six-column page of a newspaper.

PRICE OF APPARATUS AND OUTFIT.

	Size 8½ x 14 Inches.	Size 12 x 20 Inches.	Size 18 x 26 Inches.
Combined furnace and casting box	\$33 00	\$45 00	\$85 00
Iron bars, spacings and cores for type-high casts	10 00	13 00	15 00
Iron shoot-board and plane	9 00	12 00	15 00
Iron miter box and metal saw	8 00	10 00	12 00
Beating brush	3 00	3 00	3 00
Steel gauges for thin plates, small tools, blankets, brushes, prepared matrix paper, directions, etc.	7 00	7 00	10 00
Prices, when ordered complete	\$65 00	\$90 00	\$140 00

PREPARED MATRIX PAPER.

Size, 12 x 19 inches, per dozen, by express	\$0 50
Size, 19 x 24 inches, per dozen, by express	1 00

HOKE CROWN ENGRAVING PLATES.

(PATENTED.)

A Crown Engraving Plate consists of a thin, dark, steel plate, covered with a soft, white composition. By means of special tools, used after the manner of pens, the drawing is made by cutting through the composition to the dark surface of the steel plate, which shows the drawing as it will appear when printed. No apprenticeship is needed. Anyone able to draw can do the work. Speed is gained by practice. Three or four tools and a scraping brass is all that is required for ordinary work. After the drawing is finished, a stereotype cast is made from it and the cut is ready for the press. The quickness and cheapness of the process are apparent. Any stereotype foundry can cast the plates, but for those who desire to do their own casting we have special simple and cheap stereotyping outfits suited to every line of work.

This process is suitable for rapid newspaper illustration. A cut may be got ready inside of thirty minutes.

PRICE LIST AND TELEGRAPH CODE.

The telegraphic code will be found convenient when plates are wanted in a hurry.

Size.	Net Price.	Tel. Code.	Size.	Net Price.	Tel. Code.
3 × 4 ins.	per doz. \$ 4 50	—	10 × 12 ins.	each, \$3 25	Hart.
3½ × 5 ins.	per doz. 6 50	Breton.	10 × 18 ins.	each, 4 25	Inness.
4 × 6 ins.	per doz. 9 00	Church.	12 × 16 ins.	each, 4 75	Johnson.
5 × 6 ins.	per doz. 11 00	Dore.	12 × 20 ins.	each, 5 75	Kelly.
5 × 8 ins.	per doz. 15 00	Errett.	16 × 16 ins.	each, 6 25	Leslie.
6 × 10 ins.	per doz. 21 60	Frost.	16 × 20 ins.	each, 7 75	Max.
8 × 10 ins.	each, 2 50	Gaul.	18 × 20 ins.	each, 8 25	—

A credit of 15 per cent. allowed for used base plates returned in good order, freight prepaid.

HOKE STEREOTYPE CASTING BOXES.

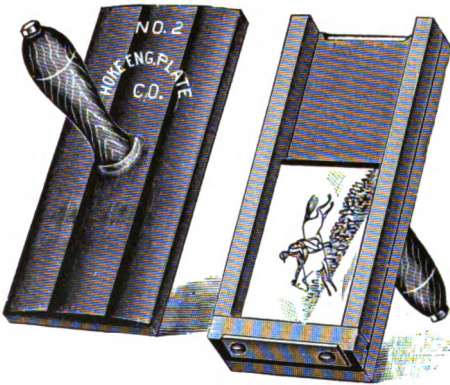

Fig. 1.

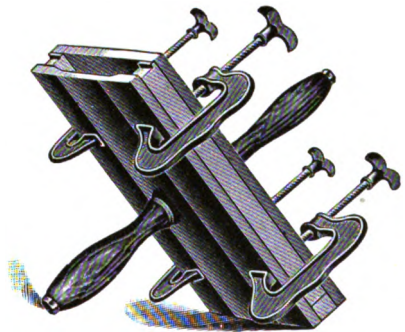

Fig. 2.

Figure 1 shows No. 2 Casting Box, with a 5 × 8 inch engraving plate laid in and the gauge bars adjusted to it, preparatory to putting on the top. Figure 2 shows the same, with the parts clamped together and ready to receive the molten metal.

- No. 2 Casting Box, 5 × 8 inches, complete, for casting thin or type high \$16 50 net.
- No. 3 Casting Box, 8 × 10 inches, complete, for casting thin or type high 22 00 net.

APPLIANCES FOR ENGRAVING ON THE CROWN ENGRAVING PLATES.

- Hoke Engraving Tools, set of four, with scraping brass \$ 2 00 net.
- Hoke Engraving Tools, each 0 50 net.
- Tracing Needles, for transferring drawing upon the composition of plate, each 0 15 net.
- Circle Former, for describing circles of all diameters, each 0 75 net.
- Plategraph, for tracing from drawing or print, reducing or enlarging the work 12 50 net.

AIR TOOLS FOR REMOVING DUST FROM PLATES.

- Bulb Blower, operated by hand \$ 1 00 net.
- Foot Blower, operated by treadle, with stand and pump 20 00 net.
- Foot Blower, without stand 15 00 net.

HAMILTON NEWSPAPER FILE.

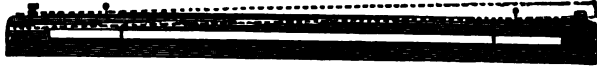

Made of cherry, finished in oil, with brass fastenings and polished steel thumb-screws. The method of opening and closing this file is novel and simple. The clasp end of file has a flat-headed thumb-screw (see cut), which is passed through a slot, and by giving the screw a quarter turn the file is securely locked. When the head is turned parallel with the file it opens instantly.

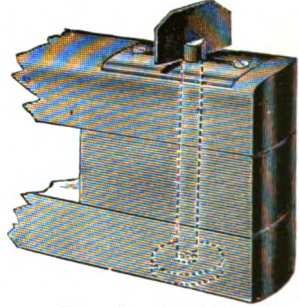

Fastening, closed.

Price, each \$1 25

The following sizes are made:

- To hold sheet 20 in. long.
- To hold sheet 22 in. long.
- To hold sheet 24 in. long.
- To hold sheet 26 in. long.
- To hold sheet 28 in. long.
- To hold sheet 30 in. long.
- To hold sheet 34 in. long.
- Other sizes to order.

PANELED BACKING FOR ELECTROTYPES.

The Only Backing that Will Not Warp Under any Circumstances.

These paneled blocks are made in two-foot lengths, and put up in any width desired. They usually are ordered with half-inch variations. This is the only perfect backing for large cuts. Sold in lots of fifty feet.

Price per square foot . . . \$0 20

Special prices for large lots or regular supply. *Made to order only.*

BACKING FOR ELECTROTYPES.

Made from selected, well-seasoned stock, and kiln dried. This is supplied to any height desired, planed perfectly smooth and flat on both sides, uniform in thickness, and free from knots or waste. It is put up in boxes, each containing 100 feet, cut in 2-foot lengths, assorted widths, 2⁵/₃₂-inch high, for use without replaning, and 7³/₈-inch high for replaning with Daniels Planer before use, but can be supplied to order to other thicknesses if required. The use of this backing results in saving of space and absence of waste.

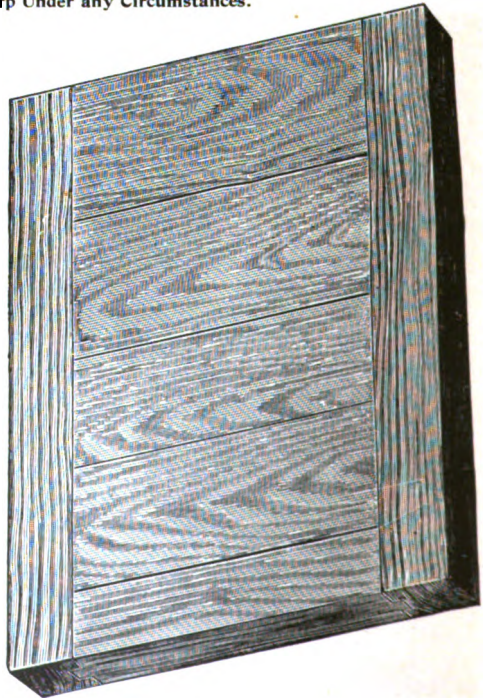

Birch, per square foot, in boxes of 100 feet \$0 10

SOLID-FACE TINT BLOCKS.

Most useful for the rapid setting up of tint forms. These blocks have a perfect, smooth surface, and print solidly.

1 Pica wide, per foot	\$0 10	10 Picas wide, per foot	\$0 48
2 Picas wide, per foot	0 12	12 Picas wide, per foot	0 50
3 Picas wide, per foot	0 15	15 Picas wide, per foot	0 66
4 Picas wide, per foot	0 20	18 Picas wide, per foot	0 75
5 Picas wide, per foot	0 22	20 Picas wide, per foot	0 80
6 Picas wide, per foot	0 24	24 Picas wide, per foot	0 85
8 Picas wide, per foot	0 36		

Prices are net.

Larger pieces squared up, any size desired, at 1 cent per square inch.

LABOR-SAVING TINT BLOCKS.

These consist of strips of engravers' maple, with polished face, cut to even Picas and Nonpareils in width. A font consists of two pieces each 1, 1½, 2, 2½, 3, 3½, 4, 5, 6 and 8 ems Pica wide, all eight inches long. All the printer has to do to make a tint is to set his panel to even Picas, select a tint strip of same width, and cut it the desired length.

Price, per font, net \$1 00

MAPLE BLOCKS.

The following are standard sizes, and are kept in stock at factory. Other sizes made to order for 1½ cents per square inch. Minimum charge, 25 cents. Prices are net.

10 × 10 inches	\$1 00	15 × 15 inches	\$2 25
10 × 12 inches	1 20	16 × 18 inches	2 88
12 × 12 inches	1 44	12 × 24 inches	2 88
12½ × 12½ inches	1 50	18 × 18 inches	3 24
14 × 14 inches	1 96	15 × 30 inches	4 50

WOOD CIRCLES.

Made any size, mortised, with square or round bodies, as preferred. Prices are net.

1- to 2-inch diameter, inside, each	\$0 40
2- to 4-inch diameter, inside, each	0 75
4- to 6-inch diameter, inside, each	1 00
6- to 8-inch diameter, inside, each	1 25
8- to 10-inch diameter, inside, each	1 75

EVERYTHING FOR THE PRINTER

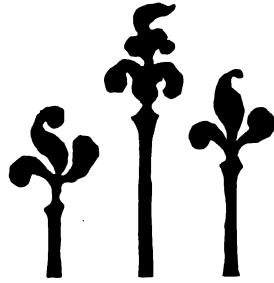

EVERYTHING made—Everything shown in any Price-List—Everything that may be made in the future—for use in the Printing Office can be purchased direct from any of the **BRANCH HOUSES** of the

AMERICAN TYPE FOUNDERS CO.

YOUR orders are solicited. All orders will be filled in accordance with the expressed preferences of customers. Our aim is to satisfy you as fully with Printing Material as we do with Type.

**BRANCHES
COVERING THE
CONTINENT**

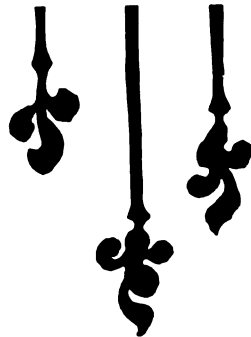

USEFUL INFORMATION FOR PRINTERS

HOW TO ESTIMATE.

To ascertain the quantity of body type required for a publication, find the number of square inches and divide the same by four, and the quotient will be the approximate weight of type required; but, as it is impossible to set the cases entirely clear, it is necessary to add 25 per cent. to the weight of large fonts, and 33 1/3 per cent. to small fonts, to allow for dead letter.

TABLE FOR NEWSPAPER ESTIMATES.

Showing the number of ems of the different sizes of newspaper type in a line, the number of lines necessary to make 1000 ems, and the length in inches; the number of ems in the regular lengths of columns, and number of leads required. There are 66 13-em 2-point leads in one pound.

ESTIMATED ON WIDTH OF STANDARD COLUMN, 13 EMS PICA.	6 1/2 POINT	6 POINT	7 POINT	8 POINT	9 POINT	10 POINT
Number ems in line	28 3/4	26	22 1/4	19 1/2	17 1/2	15 1/2
Number lines in 1000 ems	35 1/2	38 1/2	45	51 1/2	57 1/2	64 1/2
Number inches in 1000 ems	2 3/8	3 1/4	4 3/8	5 3/8	7 1/4	9
4-Column Folio or Quarto } number ems {	5040	4325	3175	2465	1950	1610
5-Column Folio or Quarto } in column {	6505	5615	4115	3200	2525	2085
6-Column Folio or Quarto }	7180	6160	4515	3510	2770	2290
7-Column Folio or Quarto }	7900	6785	4970	3865	3050	2520
8-Column Folio, number ems in column	8630	7410	5440	4220	3330	2755
9-Column Folio, number ems in column	9310	8030	5885	4575	3615	2970
2 Point leads in 1000 ems of leaded matter	26	29	35	41	47	54
2 Point leads in column, 4-column paper	132	124	110	99	90	82
2 Point leads in column, 5-column paper	170	160	142	128	116	107
2 Point leads in column, 6-column paper	190	178	158	142	129	119
2 Point leads in column, 7-column paper	209	196	174	157	142	131
2 Point leads in column, 8-column paper	221	207	184	166	151	138
2 Point leads in column, 9-column paper	266	250	222	200	182	167
Weight of 2-Point leads in 1000 ems of leaded matter	6 oz.	7 oz.	8 1/2 oz.	10 oz.	11 1/2 oz.	13 oz.
Weight of 2-Point leads needed to lead 1000 ems of solid matter	8 1/2 oz.	9 1/2 oz.	11 oz.	12 1/2 oz.	14 oz.	16 oz.

RELATIVE PROPORTION OF TYPE BODIES.

Table showing the number of ems of different bodies contained in 1000 ems space of any given body. Also the weight and space occupied by 1000 ems of any body. Also the number of ems of any body, and the number of inches, in one pound.

1000 EMS OF	3 1/2 POINT	4 1/2 POINT	5 POINT	5 1/2 POINT	6 POINT	7 POINT	8 POINT	9 POINT	10 POINT	11 POINT	12 POINT	WEIGHT	SQ. INCHES
3 1/2 Point		605	490	405	341	250	192	151	122	101	85	10 oz.	2.36
4 1/2 Point	1653		810	670	563	413	316	250	203	167	141	1 1/4 lbs.	3.91
5 Point	2041	1235		827	695	510	391	309	250	207	174	1 1/2 lbs.	4.82
5 1/2 Point	2469	1493	1210		840	617	473	373	303	250	210	1 3/4 lbs.	5.83
6 Point	2940	1780	1440	1192		735	563	445	360	297	250	1 3/4 lbs.	6.94
7 Point	4000	2420	1960	1620	1364		766	604	490	405	340	2 1/4 lbs.	9.44
8 Point	5224	3160	2560	2116	1780	1306		790	640	529	445	3 1/4 lbs.	12.35
9 Point	6612	4000	3240	2680	2252	1653	1266		810	670	564	4 1/4 lbs.	15.62
10 Point	8164	4940	4000	3308	2780	2041	1563	1236		828	696	5 lbs.	19.29
11 Point	9876	5972	4840	4000	3360	2469	1891	1492	1210		840	6 1/4 lbs.	23.30
12 Point	11756	7112	5760	4760	4000	2939	2250	1778	1440	1190		7 1/4 lbs.	27.77
Ems in one lb.	1600	960	790	650	550	400	300	240	200	160	140		3.75
Ems in square inch	422 2/3	256	207 1/2	171 1/2	144	105 1/2	81	64	51 1/2	42 2/3	36	4 1/4 oz.	

NUMBER OF EMS IN ONE POUND OF TYPE.

Two by two inches (four square inches) solid type weighs approximately one pound :

5 Point	EM8	7 Point	EM8	10 Point	EM8
5½ Point	829	8 Point	423	11 Point	207
6 Point	685	9 Point	324	12 Point	171
	576		256		144

NUMBER OF EMS IN SQUARE INCHES OF TYPE.

[Copyrighted by D. Ramaley.]

8Q. IN.	6 PT.	7 PT.	8 PT.	9 PT.	10 PT.	11 PT.	12 PT.	8Q. IN.	6 PT.	7 PT.	8 PT.	9 PT.	10 PT.	11 PT.	12 PT.
1 . . .	144	106	81	64	52	43	36	29 . . .	4176	3074	2349	1856	1508	1249	1044
2 . . .	288	212	162	128	104	86	72	30 . . .	4320	3180	2430	1920	1560	1292	1080
3 . . .	432	318	243	192	156	129	108	31 . . .	4464	3286	2511	1984	1612	1335	1116
4 . . .	576	424	324	256	208	172	144	32 . . .	4608	3392	2592	2048	1664	1378	1152
5 . . .	720	530	405	320	260	215	180	33 . . .	4752	3498	2673	2112	1716	1421	1188
6 . . .	864	636	486	384	312	258	216	34 . . .	4896	3604	2754	2176	1768	1464	1224
7 . . .	1008	742	567	448	364	301	252	35 . . .	5040	3710	2835	2240	1820	1507	1260
8 . . .	1152	848	648	512	416	348	288	36 . . .	5184	3816	2916	2304	1872	1550	1296
9 . . .	1296	954	729	576	468	387	324	37 . . .	5328	3922	2997	2368	1924	1593	1332
10 . . .	1440	1060	810	640	520	430	360	38 . . .	5472	4028	3078	2432	1976	1636	1368
11 . . .	1584	1166	891	704	572	473	396	39 . . .	5616	4134	3159	2496	2028	1679	1404
12 . . .	1728	1272	972	768	624	516	432	40 . . .	5760	4240	3240	2560	2080	1722	1440
13 . . .	1872	1378	1053	832	676	559	468	41 . . .	5904	4346	3321	2624	2132	1765	1476
14 . . .	2016	1484	1134	896	728	602	504	42 . . .	6048	4452	3402	2688	2184	1808	1512
15 . . .	2160	1590	1215	960	780	645	540	43 . . .	6192	4558	3483	2752	2236	1851	1548
16 . . .	2304	1696	1296	1024	832	688	576	44 . . .	6336	4664	3564	2816	2288	1894	1584
17 . . .	2448	1802	1377	1088	884	733	612	45 . . .	6480	4770	3645	2880	2340	1937	1620
18 . . .	2592	1908	1458	1152	936	776	648	46 . . .	6624	4876	3726	2944	2392	1980	1656
19 . . .	2736	2014	1539	1216	988	819	684	47 . . .	6768	4982	3807	3008	2444	2023	1696
20 . . .	2880	2120	1620	1280	1040	862	720	48 . . .	6912	5088	3888	3072	2496	2066	1728
21 . . .	3024	2226	1701	1344	1092	905	756	49 . . .	7056	5194	3969	3136	2548	2109	1764
22 . . .	3168	2332	1782	1408	1144	948	792	50 . . .	7200	5300	4050	3200	2600	2152	1800
23 . . .	3312	2438	1863	1472	1196	991	828	60 . . .	8640	6360	4860	3840	3120	2580	2160
24 . . .	3456	2544	1944	1536	1248	1034	864	70 . . .	10080	7420	5670	4480	3640	3010	2520
25 . . .	3600	2650	2025	1600	1300	1077	900	80 . . .	11520	8480	6480	5120	4160	3440	2880
26 . . .	3744	2756	2106	1664	1352	1120	936	90 . . .	12960	9540	7290	5760	4680	3870	3240
27 . . .	3888	2862	2187	1728	1404	1163	972	100 . .	14400	10600	8100	6400	5200	4300	3600
28 . . .	4032	2968	2268	1792	1456	1206	1108								

NUMBER OF LEADS TO THE POUND.

Table showing the approximate number of 2-point and 3-point leads contained in a pound. For 1-point leads, multiply the 2-point columns by 2. For 1½-point leads, multiply the 3-point columns by 2. For 6-point slugs, divide 3-point columns by 2.

EM8 LONG	2 POINT	3 POINT	EM8 LONG	2 POINT	3 POINT	EM8 LONG	2 POINT	3 POINT	EM8 LONG	2 POINT	3 POINT
3	288	192	15	57	38	27	31	21	39	22	15
4	216	144	16	54	36	28	30	20	40	21	14
5	168	112	17	51	34	29	30	20	41	21	14
6	144	96	18	48	32	30	29	19	42	20	14
7	123	82	19	45	30	31	28	19	43	20	13
8	108	72	20	42	28	32	27	18	44	19	13
9	96	64	21	40	27	33	26	17	45	19	13
10	84	56	22	39	26	34	25	17	46	18	12
11	78	52	23	37	25	35	24	16	47	18	12
12	72	48	24	36	24	36	24	16	48	18	12
13	66	44	25	34	23	37	23	15	49	17	11
14	61	41	26	33	22	38	22	15	50	17	11

ROMAN NUMERALS.

I—1	VI—6	XI—11	XVI—16	XXX—30	LXXX—80	CCC—300	DCCC—800
II—2	VII—7	XII—12	XVII—17	XLI—40	XC—90	CCCC—400	DCCCC—900
III—3	VIII—8	XIII—13	XVIII—18	L—50	C—100	D—500	M—1000
IV—4	IX—9	XIV—14	XIX—19	LX—60	CL—150	DC—600	
V—5	X—10	XV—15	XX—20	LXX—70	CC—200	DCC—700	

APPROXIMATE NUMBER OF WORDS IN A SQUARE INCH.

In calculating the number of pages a manuscript will occupy, these figures may be used:

	WORDS TO SQ. IN.		WORDS TO SQ. IN.
22 Point	4	9 Point, leaded	21
18 Point, solid	7	8 Point, solid	32
14 Point, solid	11	8 Point, leaded	23
12 Point, solid	14	7 Point, solid	38
12 Point, leaded	11	7 Point, leaded	27
11 Point, solid	17	6 Point, solid	47
11 Point, leaded	14	6 Point, leaded	34
10 Point, solid	21	5 Point, solid	69
10 Point, leaded	16	5 Point, leaded	50
9 Point, solid	28		

" Leaded," as here used, means an opening of lines with 2-point leads.

USEFUL IN ORDERING SORTS.

The following table shows what each box in the type case will hold :

a c d i s m n h o u t r	boxes, each hold	2 pounds.
f b l v g y p w	boxes, each hold	15 ounces.
k j z x q and all figures	boxes, each hold	6 ounces.
e	box holds	3 pounds.
Caps and Small Caps	boxes, each hold	5 ounces.

TO PRINT CONSECUTIVE NUMBERS.

Orders to print consecutive numbers are received more or less frequently by every printing office, large or small. In the average office, to print the numbers 1 to 200 consecutively would be quite a task, and when undertaken in the ordinary way, with the facilities usually at hand, the cost is so high that the customer usually concludes to get along with something else than printed numbers, and what might be a profitable job is lost to the office.

A	B	C	D	E	F	G	H	I	K	L
1	11	21	31	41	51	61	71	81	91	01
2	22	32	42	52	62	72	82	92	02	12
3	33	43	53	63	73	83	93	03	13	23
4	44	54	64	74	84	94	04	14	24	34
5	55	65	75	85	95	05	15	25	35	45
6	66	76	86	96	06	16	26	36	46	56
7	77	87	97	07	17	27	37	47	57	67
8	88	98	08	18	28	38	48	58	68	78
9	99	09	19	29	39	49	59	69	79	89
0	00	10	20	30	40	50	60	70	80	90

Suppose an order for two hundred reserved seat numbers from 1 to 200, six copies of each. It is not necessary to set up more than the units 1 to 0. These figures are to be set up, properly spaced, one above the other, as shown in column A of the table annexed.

One hundred and twenty impressions are taken on strips of cardboard cut to the required width. This done, gives the required number of units. Change the gauge pins in a manner to print the same form beside the printed figures to form the tens, as shown in column B of the table. Take twelve impressions of this form on twelve of the already printed strips. The next step is to change the form by taking the top figure (1) and place it at the bottom of the column, so the next impression on a strip of the first form will read as shown in column C of the table. We print again twelve strips of the first form. This change of the top figures, 2, 3, 4, 5, 6, 7, 8, 9 and 0, respectively, is repeated eight more times, shown in the table as columns D, E, F, G, H, I, K and L. From each change twelve impressions on the printed slips containing the first form must be made. This will finish the tens, and by changing the form to ten figure 1s and again moving the pins to the left for the space-width of the type, and printing six strips of each the former changes from B to L, gives the hundreds, or a continuous run of numbers from 1 to 199 in an edition of six copies. To obtain number 200, print upon the six strips left a figure 2 to head the 00 of column B. In assorting the numbers it will be found that each six copies of the heavy type cannot be used, but this small loss in stock is compensated many times by the advantage derived from the method.

PROOFREADER'S MARKS.

- X Change bad letter.
- ⌞ Push down space.
- 9 Turn.
- 8 Take out (*delete*).
- ^ Left out; insert.
- * Insert space.
- v Even spacing.
- ⌒ Less space.
- ⊂ Close up entirely.
- ⊙ Period.
- / Comma.
- ⊙ Colon.
- ;/ Semicolon.
- ∨ Apostrophe.
- ∨ Quotation.
- / Hyphen.
- ≡ Straighten lines.
- Move over.
- Em-quad space.
- /- One-em dash.
- /- Two-em dash.
- ¶ Paragraph.
- No ¶ No paragraph.
- w. f. Wrong font.
- . . . Let it stand.
- stet. Let it stand.
- tr. Transpose.
- Caps Capital letters.
- s. c. Small caps.
- l. c. Lower case or small letters.
- Ital. Italics.
- Rom. Roman.

TABLE SHOWING THE AMOUNT OF PAPER REQUIRED

for any job of from 50 to 5000 copies. No allowance is made for waste.

NO. OF COPIES REQUIRED.	2		3		4		6		8		9		12		16		18		20		24		32		
	TO THE SHEET	QUIRES SHEETS	TO THE SHEET	QUIRES SHEETS	TO THE SHEET	QUIRES SHEETS	TO THE SHEET	QUIRES SHEETS	TO THE SHEET	QUIRES SHEETS	TO THE SHEET	QUIRES SHEETS	TO THE SHEET	QUIRES SHEETS	TO THE SHEET	QUIRES SHEETS	TO THE SHEET	QUIRES SHEETS	TO THE SHEET	QUIRES SHEETS	TO THE SHEET	QUIRES SHEETS	TO THE SHEET	QUIRES SHEETS	
50	1-1		0-17		0-13		0-9		0-7		0-6		0-5		0-4		0-4		0-3		0-3		0-03		0-2
100	2-2		1-10		1-1		0-17		0-13		0-12		0-9		0-7		0-7		0-6		0-5		0-05		0-4
200	4-4		2-19		2-2		1-10		1-1		0-23		0-17		0-14		0-13		0-12		0-10		0-09		0-7
250	5-5		3-12		2-15		1-18		1-8		1-4		0-21		0-17		0-16		0-14		0-13		0-11		0-9
300	6-6		4-4		3-2		2-2		1-14		1-10		1-1		0-20		0-19		0-17		0-15		0-13		0-10
400	8-8		5-14		4-4		2-19		2-2		1-21		1-10		1-3		1-1		0-23		0-20		0-17		0-13
500	10-10		6-23		5-5		3-12		2-15		2-8		1-18		1-10		1-8		1-4		1-1		0-21		0-16
600	12-12		8-8		6-6		4-4		3-3		2-19		2-2		1-16		1-14		1-10		1-6		1-1		0-19
700	14-14		9-18		7-7		4-21		3-16		3-6		2-11		1-23		1-20		1-15		1-11		1-6		0-22
750	15-15		10-10		7-20		5-5		3-22		3-12		2-15		2-2		1-23		1-18		1-14		1-8		1-0
800	16-16		11-3		8-8		5-14		4-4		3-17		2-19		2-6		2-2		1-21		1-16		1-10		1-1
900	18-18		12-12		9-9		6-6		4-17		4-4		3-3		2-12		2-9		2-2		1-21		1-14		1-5
1000	20-20		13-22		10-10		6-23		5-5		4-16		3-12		2-19		2-15		2-8		2-2		1-18		1-8
1250	26-1		17-9		13-1		8-17		6-13		5-19		4-9		3-12		3-7		2-22		2-15		2-5		1-16
1500	31-6		20-20		15-15		10-10		7-20		6-23		4-9		4-5		3-22		3-12		3-3		2-15		1-23
1750	36-11		24-8		18-6		12-4		9-3		8-3		6-2		4-22		4-14		4-2		3-16		3-1		2-8
2000	41-16		27-10		20-20		13-22		10-10		9-7		6-23		5-14		5-5		4-16		4-4		3-12		2-15
2500	52-2		31-18		26-1		17-10		13-1		11-15		8-17		7-0		6-13		5-20		5-5		4-9		3-7
3000	62-12		44-16		31-6		20-20		15-15		13-22		10-10		8-8		7-20		6-23		6-6		5-5		3-22
4000	83-8		55-14		41-16		27-19		20-20		18-13		13-22		11-3		10-10		9-7		8-8		6-23		5-5
5000	104-4		69-11		52-2		34-18		26-1		23-4		17-9		13-22		13-1		11-14		10-10		8-17		6-13

DIRECTIONS FOR SECURING COPYRIGHTS

Under the Revised Acts of Congress, including the Provisions for Foreign Copyright, by Act of March 3, 1891.

1. A *printed copy* of the title of the book, map or chart, dramatic or musical composition, engraving, cut, print, photograph or chromo. or a *description* of the painting, drawing, statue, statuary or model or design for a work of the fine arts, for which copyright is desired, must be delivered to the Librarian of Congress or deposited in the mail, within the United States, *prepaid*, addressed "LIBRARIAN OF CONGRESS, WASHINGTON, D. C." This must be done on or before day of publication in this or any foreign country.

The *printed title* required may be a copy of the title page of such publications as have title pages. *In other cases the title must be printed expressly for copyright entry*, with name of claimant of copyright. The style of type is immaterial, and the print of a typewriter will be accepted. But a separate title is required for each entry, and *each* title must be printed on paper as large as commercial note. The title of a *periodical* must include the date and number; and each number of the periodical requires a separate entry of copyright.

Copyright fees.

2. The legal fee for *recording* each copyright claim is 50 cents, and for a *copy* of this record (or certificate of copyright under seal of the office) an additional fee of 50 cents is required, making \$1 if certificate is wanted, which will be mailed as soon as reached in the records.

For publications which are the production of persons not citizens or residents of the United States, the fee for recording title is \$1, and 50 cents additional for a copy of the record. Certificates covering more than one entry in one certificate are not issued.

Two copies required.

3. Not later than the day of publication in this country or abroad, two complete copies of the best edition of each book or other article must be delivered, or deposited in the mail within the United States, addressed "LIBRARIAN OF CONGRESS, WASHINGTON, D. C.," to perfect the copyright.

The freight or postage must be prepaid, or the publications inclosed in parcels covered by printed Penalty Labels, furnished by the Librarian, in which case they will come FREE by mail (*not express*), without limit of weight, according to rulings of the Post Office Department. Books must be printed from type set or plates made in the United States; photographs from negatives made in the United States; chromos and lithographs from drawings on stone or transfers therefrom made in the United States.

Free by mail.**To be American made.****Penalty.**

Without the deposit of copies above required the copyright is void, and a penalty of \$25 is incurred. No copy is required to be deposited elsewhere.

New editions.

The law requires one copy of each new edition, wherein any substantial changes are made, to be deposited with the Librarian of Congress.

Notice of copyright to be given by imprint.

4. No copyright is valid unless notice is given by inserting in every copy published, on the title page or the page following, if it be a book; or if a map, chart, musical composition, print, cut, engraving, photograph, painting, drawing, chromo, statue, statuary or model or design intended to be perfected as a work of the fine arts, by inscribing upon some portion thereof, or on the substance on which the same is mounted, the following words, viz.: "*Entered according to Act of Congress, in the year—, by—, in the office of the Librarian of Congress, at Washington,*" or, at the option of the person entering the copyright, the words: "*Copyright, 18—, by—.*"

Claimant's name to be printed.**Penalty for false claim.**

The law imposes a penalty of \$100 upon any person who has not obtained copyright who shall insert the notice "*Entered according to Act of Congress,*" or "*Copyright,*" etc., or words of the same import, in or upon any book or other article.

Translations and dramas.

5. The copyright law secures to authors and their assigns the exclusive right to translate or to dramatize any of their works; no notice or record is required to enforce this right.

Duration of copyright.

6. The original term of copyright runs for twenty-eight years. *Within six months before* the end of that time, the author or designer, or his widow or children, may secure a renewal for the further term of fourteen years, making forty-two years in all. Applications for renewal must be accompanied by a printed title and fee, and by explicit statement of ownership in the case of the author, or of relationship in the

Renewals.

case of his heirs, and must state definitely the date and place of entry of the original copyright. Within two months from date of renewal the record thereof must be advertised in an American newspaper for four weeks.

- Time of publication.** 7. The time of publication is not limited by any law or regulation, but the courts have held that it should take place within a reasonable time. A copyright may be secured for a projected as well as for a completed work; but the law provides for no *caveat* or notice of interference—only for actual entry of title.
- Assignments.** 8. Copyrights are assignable by any instrument of writing. Such assignment, to be valid, is to be recorded in the office of the Librarian of Congress within sixty days from execution. The fee for this record and certificate is \$1, and for a certified copy of any record of assignment \$1.
- Copies or duplicate certificates.** 9. A copy of the record (or duplicate certificate) of any copyright entry will be furnished, under seal of the office, at the rate of 50 cents each.
- Serials or separate publications.** 10. In the case of books published in more than one volume, or of periodicals published in numbers, or of engravings, photographs or other articles published with variations, a copyright must be entered for each volume or part of a book, or number of a periodical, or variety, as to style, title or inscription, of any other article. To *complete* the copyright on a book published serially in a periodical, two copies of each serial part, as well as of the complete work (if published separately), should be deposited.
- Copyright for works of art.** 11. To secure copyright for a painting, statue or model or design intended to be perfected as a work of the fine arts, a definite title and description must accompany the application for copyright, and a mounted photograph of the same, as large as "cabinet size," mailed to the Librarian of Congress not later than the day of publication of the work or design.
- Fine arts.** The fine arts, for copyright purposes, include only painting and sculpture, and articles of merely ornamental and decorative art should be sent to the Patent Office, as subjects for design patents.
- No labels or names copyrighted.** 12. Copyrights cannot be granted upon trade-marks, nor upon names of companies, libraries or articles, nor upon an idea or device, nor upon prints or labels intended to be used for any article of manufacture. If protection for such names or labels is desired, application must be made to the Patent Office, where they are registered, if admitted, at a fee of \$6 for labels and \$25 for trade-marks.
- Foreign or international copyright.** 13. The provisions as to copyright entry in the United States by foreign authors, etc., by Act of Congress approved March 3, 1891 (which took effect July 1, 1891), are the same as the foregoing, except as to productions of persons not citizens or residents, which must cover return postages, and are \$1 for entry, or \$1.50 for entry and certificate of entry (equivalent to 4s. 5d. or 6s. 7d.). All publications must be delivered to the Librarian at Washington free of charge. The free penalty-labels cannot be used outside of the United States.
- Fees.**
- The right of citizens or subjects of a foreign nation to copyright in the United States extends by Presidential proclamations to Great Britain, France, Belgium, Switzerland, Germany, Italy, Denmark and Portugal.
- Full name of proprietor required.** 14. Every applicant for a copyright should state distinctly the full name and residence of the claimant, and whether the right is claimed as author, designer or proprietor. No affidavit or witness to the application is required.

METRIC SYSTEM OF WEIGHTS AND MEASURES.

In use in all European countries except Great Britain and Russia. In use in Mexico and South America.

The Meter, unit of length, is nearly the ten-millionth part of a quadrant of a meridian, of the distance between equator and pole. The International Standard Meter is, practically, nothing else but a length defined by the distance between two lines on a platinum-iridium bar at 0° Centigrade, deposited at the International Bureau of Weights and Measures, Paris, France.

The Liter, unit of capacity, is derived from the weight of one kilogram pure water at greatest density, a cube whose edge is one-tenth of a meter, and, therefore, the one-thousandth part of a metric ton.

The Gram, unit of weight, is a cube of pure water at greatest density, whose edge is one-hundredth of a meter, and, therefore, the one-thousandth part of a kilogram, and the one-millionth part of a metric ton.

One silver dollar weighs 25 grams, 1 dime = 2½ grams, 1 five-cent nickel = 5 grams.

THE METRIC SYSTEM SIMPLIFIED.

The following tables of the metric system of weights and measures have been simplified as much as possible by Mr. John Wilkes, of Nashville, Tenn., by omitting such denominations as are not in practical, everyday use in the countries where the system is used exclusively.

TABLES OF THE SYSTEM.

LENGTH.—The denominations in practical use are millimeters (mm.), centimeters (cm.), meters (m.), and kilometers (km.).

10 mm. = 1 cm.; 100 cm. = 1 m.; 1000 m. = 1 km.
A decimeter is 10 cm.

WEIGHT.—The denominations in use are grams (g.), kilos* (kg.), and tons (metric tons).
1000 g. = 1 kg.; 1000 kg. = 1 metric ton.

CAPACITY.—The denominations in use are cubic centimeters (c.c.), and liters (l.).
1000 c.c. = 1 l.

A hectoliter is 100 l. (seldom used).

Relation of capacity and weight to length: A cubic decimeter is a liter, and a liter of water weighs a kilo.

APPROXIMATE EQUIVALENTS.

A meter is about a yard; a kilo is about 2 lbs.; a liter is about a quart; a centimeter is about ½ inch; a metric ton is about the same as a ton; a kilometer is about ½ mile; a cubic centimeter is about a thimbleful; a nickle weighs about 5 grams.

* Contraction for kilogram.

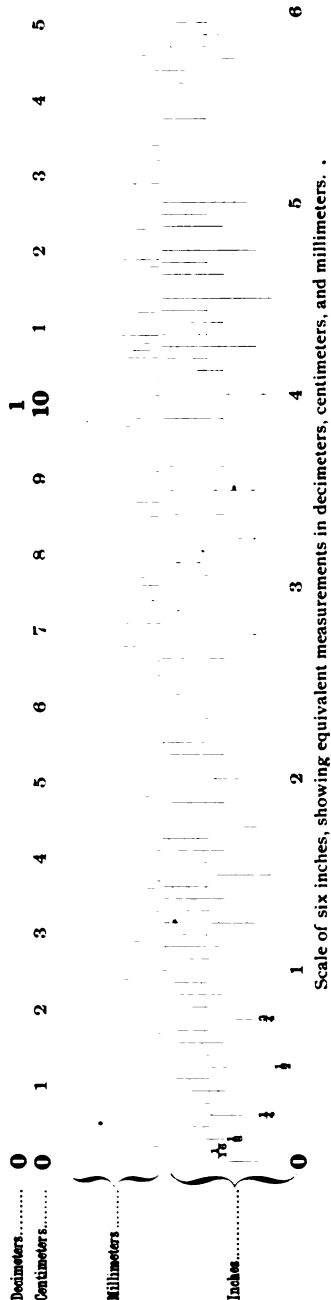

IMPOSITION OF FORMS.

HINTS ON IMPOSITION: A Hand-book for Printers. By T. B. Williams. Leather, 90 pp., \$1.00. For sale at all Branches of the American Type Founders' Company, and recommended to all who desire the fullest information concerning the imposition of forms.

The make-up should learn to use the measuring rule or tape measure and dividers. They are more convenient to measure with than paper, and their use is regarded as evidence of knowledge of the imposition of book forms. The dividers will enable the make-up to verify his measurements quickly. Printers' dividers cost 85 cents.

Ascertain what furniture will be required for the margins of a book form before placing it upon the stone. Time will be saved, and the work will have the appearance of order and neatness.

After a book form is imposed, tighten the quoins, and ascertain by means of a straight-edge or square if the pages are of equal length and the head lines or bottom folios are exactly in line. The folios are usually the guides for hand-folding and should receive great attention, otherwise the binder will not secure good register. For the same reason, folios should all be set exactly in the middle of the width of the page.

After a book form has been locked up, it should be tested for squareness with a square. Forms are liable to get twisted or bowed in locking up, especially if the chase is weak. This defect can usually be remedied by loosening the quoins on one side and tightening them on the opposite side.

MARGINS.

The proper allowances for head and back margins are matters of judgment and preference to a great degree.

The head and foot margins of a *trimmed* book are usually of equal proportions, but, as the binder will almost invariably find it necessary to cut off more paper from the foot than from the head, the make-up must make sufficient allowance for this extra trim.

When the pages have running heads one-third or less shorter than the width of the page, one-half of the space occupied by the running head should be thrown into the head margin, because the white around the running head is to be considered as part of the head margin. If a folio only is used over a page, the head margin is to be calculated from the top line of the page.

The make-up must know whether a book is to be wire-stitched through the back or sewed through the fold. If wire-stitched through the back, an extra allowance *additional* to the back margin required must be made a little in excess of the space used by the wire. This space varies according to thickness of the book, but is rarely less than three-sixteenths of an inch on *each side* of the back margin, or three-eighths of an inch in the back gutters.

In forms of 32 pages or more it is advisable, where it is possible, to impose the pages so that the sheet may be cut and folded in signatures of half the number of pages, especially when the paper is heavy; but if the form is imposed to fold as one complete signature then it is advisable to deduct enough from the back margin of the inner sections to equal the extra space taken up by the fold of the outside sections.

In imposing forms of 12 or 24 pages, great care must be taken to get the foot and head margins of the inset to be folded in exactly right, and the head and foot margins in such forms should be as evenly divided as possible. More accurate register is obtained when the inset is cut off and folded separately.

TESTING MARGINS.

After the proper head and back margins have been decided on, and the pages arranged to conform to them, the form should be tested to ascertain if the foot and front margins are correct. The method is illustrated in the accompanying diagram of a section of a 16-page form. Fold a sheet to quarter of the size of the untrimmed paper to be used. The distance from the foot of page 16 to the foot of page 10 must agree with the length of the quarter sheet (as indicated by the dotted line), and the distance from the back edge of page 7 to the back edge of page 11 must correspond with the width of the quarter sheet. This test can be made just as well by using a measuring rule or tape, in which case, if the quarter sheet were twelve inches wide by eighteen inches long, the distance from the front edge of page 12 to the front edge of page 8 must be exactly twelve inches, and the distance from the foot of page 7 to the foot of page 1 must be exactly eighteen inches.

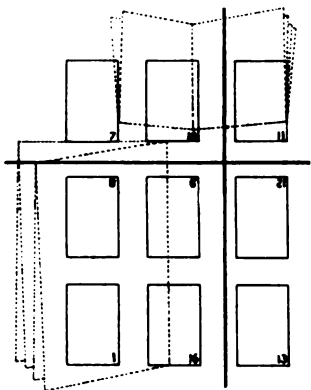

GRIPPER MARGINS.

As applied to book forms, the space between the type and the outer edge of the chase at the gripper side is the gripper margin. A gauge showing the gripper margin of each press should be obtained from the pressman. When the paper is placed in its correct position on the type form, the distance between the edge of the paper and the edge of chase should be at least half an inch less than the gripper margin, to permit the pressman to move his form into a suitable place. To make a proper allowance for gripper margin, it is often necessary to place more furniture in the foot margins on the side of the long cross-bar next the gripper than on the other side. The lowest folio of a form should be placed next the gripper edge.

CORRECT IMPOSITION OF LENGTHWISE CUTS AND TABLES.

The correct rule is that lengthwise tables and cuts shall always read from the foot of page. When a lengthwise cut or table is on one page and the explanatory or descriptive matter on the opposite page, then the cut or table should, if possible, be placed on the page with the even folio.

TESTS OF CORRECT IMPOSITION.

As a general rule, except where for convenience in folding, certain forms are imposed from the center, the lowest (first) folio of a form is placed on the lower left-hand corner. All odd folios are always at the left-hand of the make-up, as viewed from the foot.

The odd and even folios of pages which are side by side in a correctly imposed regular form will, when added together, form a total of one more than the number of pages in a signature. The first and last pages of a signature are always placed side by side—as, for instance, in a 16-page form, where folios 1 and 16 equal seventeen.

PRESS POINTS.

These are used in forms that are imposed for books, the sections of which are folded by machines. In 16-page forms these points are usually placed exactly 15 inches apart—7½ inches each way from the center of the first fold. The sheets are fed into the folding machine by the point holes to insure register, and the points should be placed exactly in accordance with the instructions of the bookbinder.

EIGHTS, IN TWO FORMS.

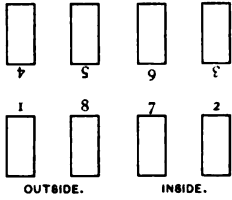

EIGHTS, WORK AND TURN.

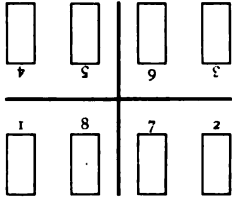

TWELVE, WITHOUT CUTTING.

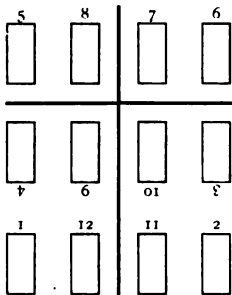

SIXTEEN, WORK AND TURN.

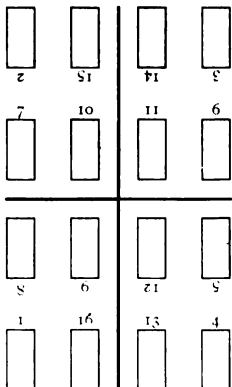

THIRTY-TWO PAGES, IN TWO FORMS.

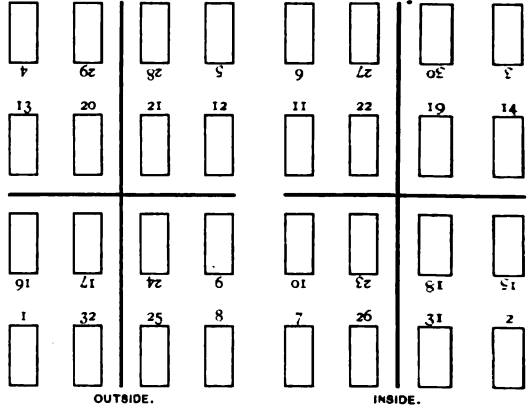

TWENTY-FOUR PAGES, IN TWO FORMS.

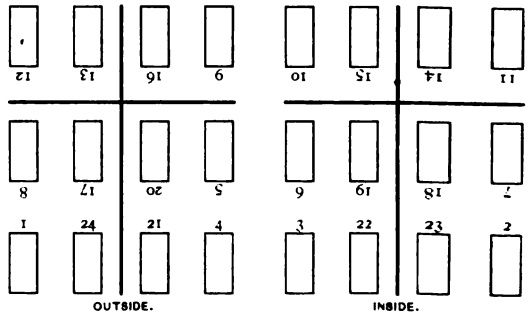

SIXTEEN PAGES, IN TWO FORMS.

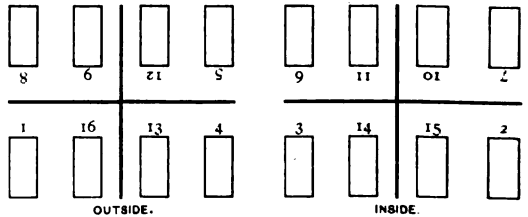

BROAD EIGHTS, IN TWO FORMS.

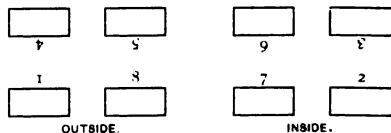

SIXTEEN PAGES, DEEP WAY.

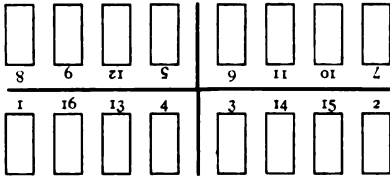

TWELVE PAGES, BROAD WAY.

In this form pages 3, 4, 9 and 10 are folded in. May frequently be used to advantage on booklets and catalogues.

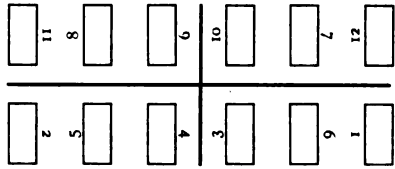

SIXTEEN PAGES, DEEP WAY.

For booklets. Paper should be trimmed before printing.

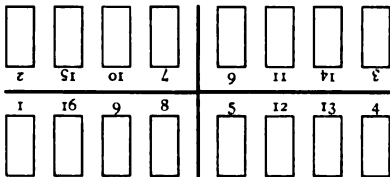

TWELVE PAGES, DEEP WAY.

This method is convenient only for deep pages, such as an odd-sized booklet, and the same size of paper used on the two regular forms for twelve pages may be used. Paper should be trimmed.

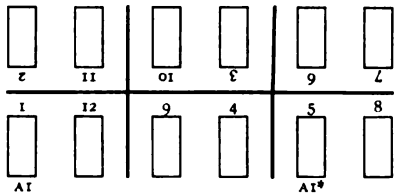

SIXTEEN PAGES, BROAD WAY, IN TWO FORMS.

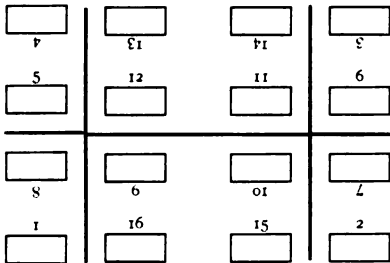

TWELVE PAGES, WITH OFF-CUT.

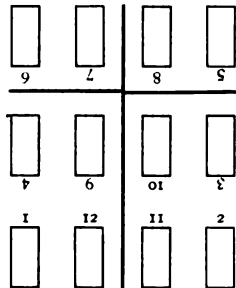

EIGHTEEN PAGES.

When the first side is worked off, transpose pages 11 and 8 in place of 7 and 12, and 7 and 12 in place of 11 and 8.

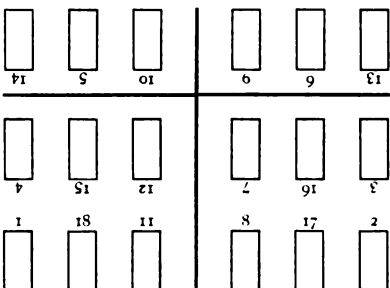

EIGHTEEN PAGES, WITHOUT TRANSPOSITION.

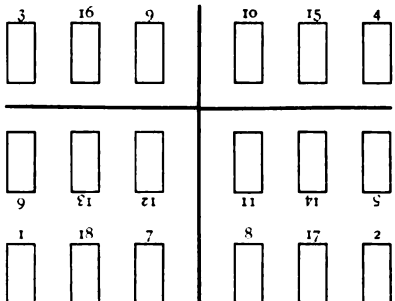

IMPOSITION OF FOLDERS.

The margins of folders are usually equal all around each page, and consequently accuracy in make-up and imposition is necessary. When the sheet is to be backed, turn it the broad way, toward the folio 2. Before printing, paper should be trimmed.

SIXTEEN-PAGE FOLDER.

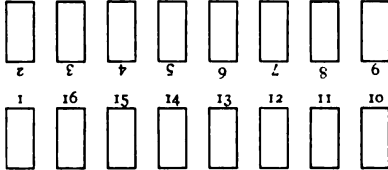

TWELVE-PAGE FOLDER.

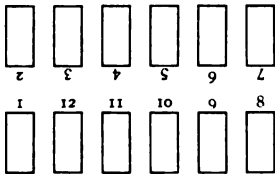

SIX-PAGE FOLDER.

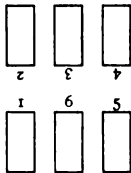

EIGHT-PAGE FOLDER.

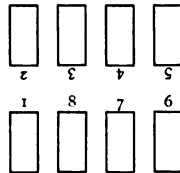

FORMS IMPOSED FROM THE CENTER.

This method of imposition is preferable in forms containing title page, copyright notice and other introductory pages with very little matter in them, as it brings the full pages outside, where they serve as bearers and often prevent slurring.

SIXTEEN PAGES, IMPOSED FROM CENTER.

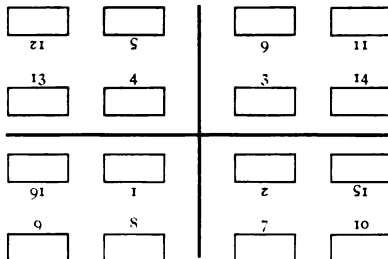

EIGHT PAGES, IMPOSED FROM CENTER.

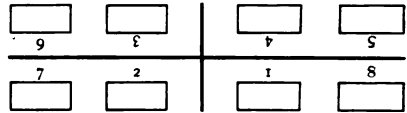

TWENTY-FOUR PAGES, IMPOSED FROM THE CENTER, IN TWO FORMS.

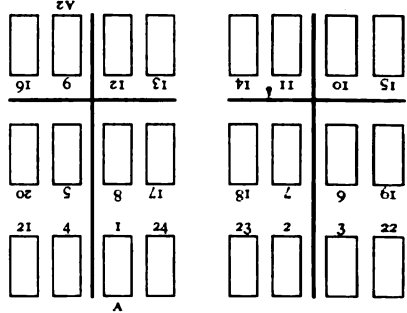

SIXTEEN PAGES, IMPOSED FROM CENTER.

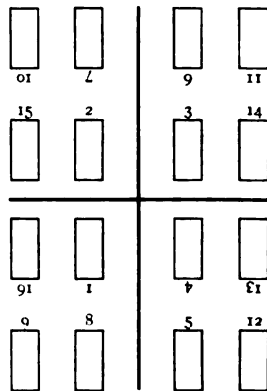

TWELVE PAGES, IMPOSED FROM CENTER.

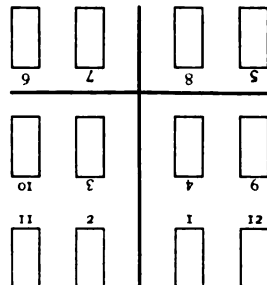

TWENTY PAGES.

Printed on double demy or double royal. This method makes a square page, suitable for booklets, where oddity is looked for.

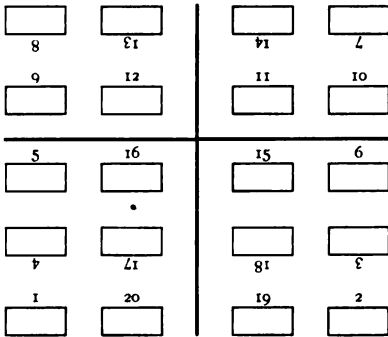

TWENTY-FOUR PAGES, DEEP WAY.

A very satisfactory form, in common use for pamphlets. Careful division of the margins is necessary, the pressman allotting the exact margin to the edge of the sheet to be folded in. Points placed as shown will assist the binder, and should be removed before backing the sheet.

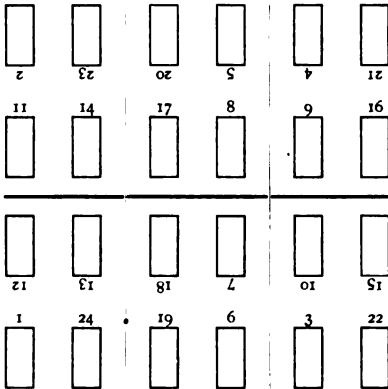

TWENTY-FOUR PAGES, WITHOUT INSET.

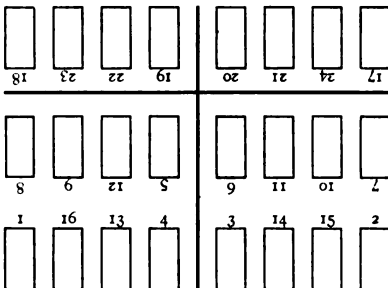

EIGHTEEN PAGES, TWO OF WHICH ARE BLANK.

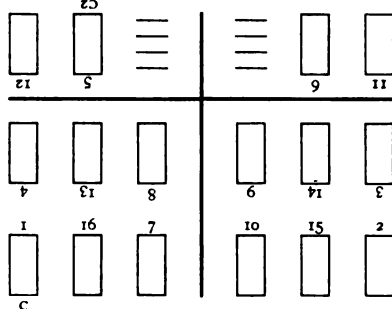

When the first side is worked off, transpose pages 7 and 10 in place of 9 and 8, and pages 9 and 8 in place of 7 and 10.

TWENTY-FOUR PAGES, WITHOUT CUTTING.

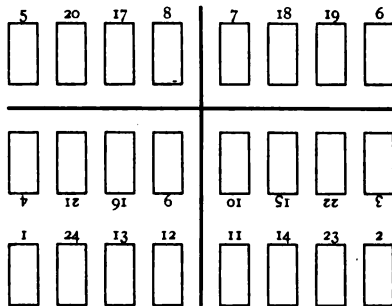

TWENTY-FOUR PAGES, BROAD WAY

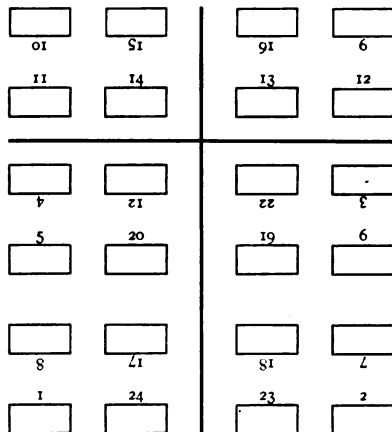

THIRTY-TWO PAGES, WITH TWO SIGNATURES.

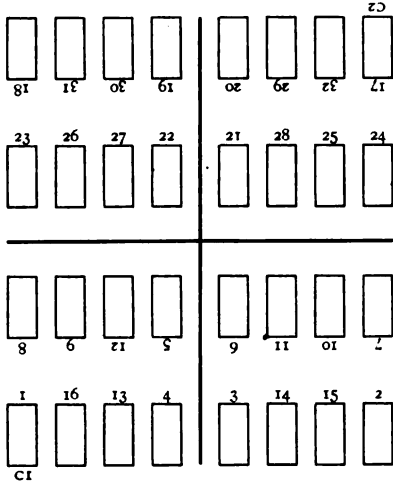

THIRTY-TWO PAGES, BROAD WAY

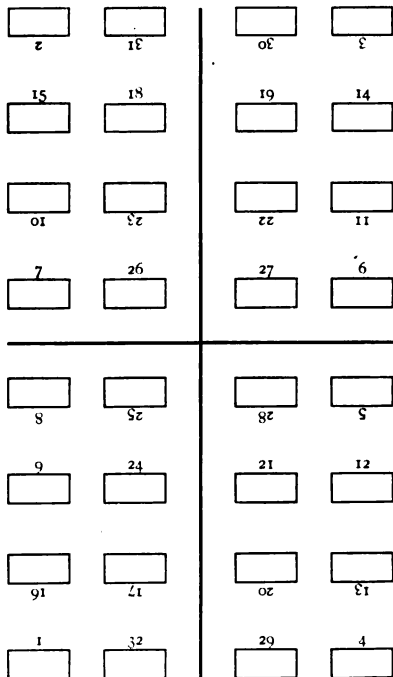

THIRTY-SIX PAGES.

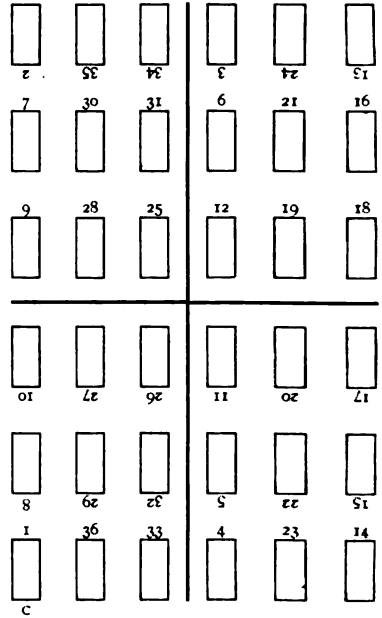

THIRTY-SIX PAGES, WITHOUT CUTTING.

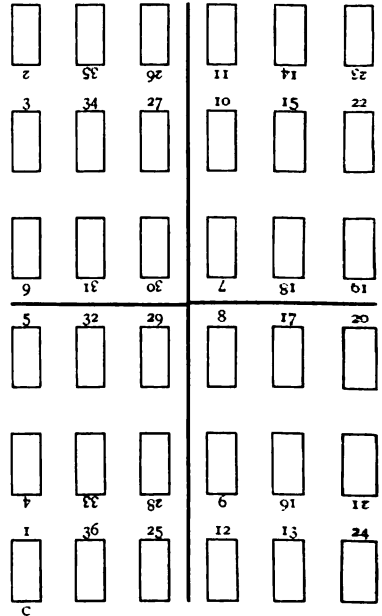

FORTY PAGES, WITH TWO SIGNATURES.

The larger signature folds same as a 32-page form. The smaller signature is an inset.

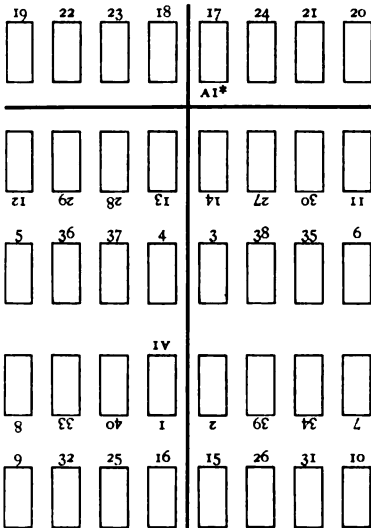

FORTY PAGES, ONE SIGNATURE.

The paper must be trimmed at ends before printing. A point should be placed where shown, about $\frac{1}{8}$ -inch from the fold, encroaching on main section of form—the pressman to deduct this space from the edge of sheet, which is folded toward the form. The division of margin must be accurate, especially at head and foot of pages.

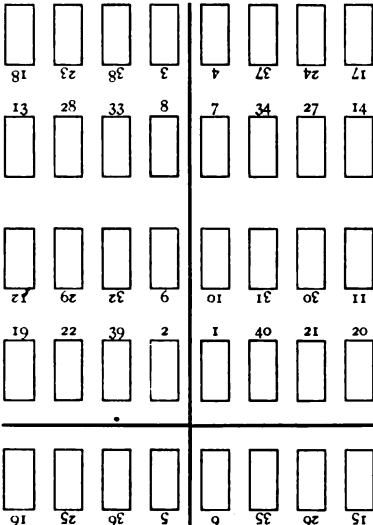

FORTY PAGES, WITH TWO SIGNATURES.

In this form there is an outset of pages, 1, 2, 3, 4, 37, 38, 39, 40, instead of an inset.

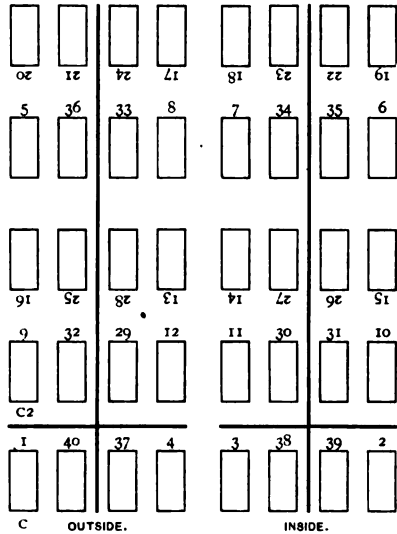

OUTSIDE.

INSIDE.

FORTY-EIGHT PAGES, WITH TWO SIGNATURES.

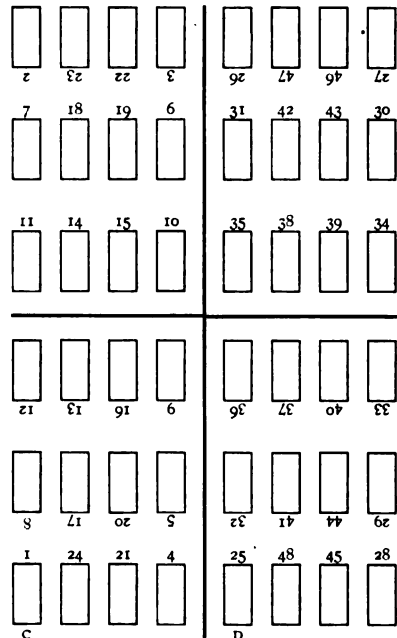

PRICE LIST OF PRINTING AND BINDING: A GUIDE FOR CHARGING.

Compiled by DAVID RAMALEY, St. Paul, Minn.

Copyrighted by David Ramaley, 1896.

The object of this publication is to unify prices, and to form a basis for agreements among printers in figuring on competitive work. The prices given are supposed to be fifty per cent. above the actual labor and material cost of the work, with ordinary conditions. The variable factor of general expense is only figured in the labor expense, because the paper or other stock used has a special expense of cutting and counting and handling equal to the proportion of general expense charge. *Twenty per cent. off from these prices will not leave twenty per cent. profit in all cases*, because sharp competition has forced down the prices of many kinds of commercial printing. A discount of twenty per cent. from the prices, in a general way, is supposed to leave twenty per cent. profit, but the factor of general expense must be considered.

INDEX TO RAMALEY'S PRICE LIST.

	PAGE		PAGE
Abstracts of title	1002	Delegate or nomination tickets	1003
Advertising matter	998, 1002	Deposit books, bankers	1017
Advertising programmes	1002	Deposit tickets	1015
Alterations	998	Drafts	1015
Announcements, printed or engraved	1008, 1009	Dodgers, hand bills and programmes	1003
Ball and dance programmes	1009	Engraved cards, invitations	1008
Bank printing	1015-1017	Envelopes, sizes of	1001
Basis for figuring value of paper	1000	Envelopes, tag, clasp, and stamped	1013, 1014
Beer, milk or restaurant tickets	1012	Guard or plat books	1022
Bill heads and monthly statements	1010	Hand bills or cheap circulars	1003
Bills of fare	1012	Hotel registers	1014
Binding, blank books	1022	Invitations, social and wedding	1008
Binding, books, magazines and newspapers	1024	Letter heads	1011
Binding, job work	1023	Note heads and memorandums	1012
Binding, pamphlets	1023	Numbering and perforating	1022
Blank books with stubs	1020, 1021	Paper, value of	1000
Blank books	1017-1020	Paper, sizes of	1001
Blanks, ruled and printed	1016	Perforating and numbering	1022
Blotting pads	1009	Postal cards and stamped envelopes	1014
Bonds and coupons	1016	Posters and show bills	1003, 1009
Booklets	1002	Presswork	999
Briefs and paper books	1003	Programmes, dance and entertainment	1009
Bronze work	999	Restaurant bills-of-fare	1012
By-laws, Constitutions, &c.	1002	Ruling on blank forms	1022
Card scale	1006, 1007	Shipping tags	1014
Cards, business	1006-1008	Sizes of flat writing paper	1001
Cards, large or show	1009	Sizes of ruled paper	1001
Checks in book	1015	Sizes of untrimmed leaf	1001
Circulars, half note	1005	Stamped envelopes	1014
Circulars, folded letter (1 to 4 pages)	1005	Standing type	998
Circulars, folded note (1 to 4 pages)	1004	Statements, monthly	1010, 1011
Circulars, half-letter or quarter-folio	1004	Tags	1014
Commission sales accounts	1022	Time work	998
Composition	998, 999	Value of paper	1000
Constitutions	1002	Visiting and wedding cards	1008
Debit and credit slips	1015	Wedding stationery	1008

SAFE BASIS ON WHICH TO DO A PROFITABLE BUSINESS.

[Adapted from the Code of Ethics of the United Typothetae of America.]

The expense of doing business, such as the wear and tear of material, interest on money invested, bad debts, rents, taxes, insurance, book-keeping, and all other items of expense, should be ever before our eyes, and we should never forget that these must be as surely levied on each particular job as its labor costs.

Always have the courage to ask for a fair remuneration for any work offered, resting assured that it will be more profitable to be without a job than to secure one in which there is a temptation to resort to questionable methods in order to avoid a financial loss in its execution.

A master printer should always contend that he is entitled, when asked for an estimate, to know the names of all who are to be requested to bid on the work. He should also insist upon his right, if he desires it, to know all the prices offered for the work and to whom and at what price it was awarded.

A master printer should not make estimates for work that he cannot do. It is always unsafe and often unjust to give prices upon a class of work upon which the cost is not positively known and has to be guessed at.

Estimates calling for detailed specifications of separate value of the paper, composition, electrotyping, presswork, ruling, binding, etc., should always be refused.

EXPLANATORY.

The prices under the several divisions of each list, such as "100," "250," "1000," include all regular charges for labor and material to the customer unless otherwise stated, and when there is a variable factor in such prices the amount estimated for such variable factor is quoted, so that the printer can readily adjust the price in accordance with the conditions governing the work. For instance, on page 1002, in Advertising Programmes, the variable factor is composition. The price for 100 4-page Advertising Programmes on 22x32 quarto print paper is \$18.25, on the basis of 8-point composition, in which amount is included a charge of \$17.20, for composition at \$4.30 per page. Now, if composition should be based on 10 Point, deduct the difference in cost, and if on 6 Point, add the difference. In other instances the variable factor is the cost of paper.

We figure composition at 70c. per 1000 in all work, including locking up or making up, and at 60c. per hour for time work.

Paper is included in these prices at an average advance of 50 per cent. on cost, unless otherwise stated; but this includes storage, handling, wastage and cutting—items that are never paid for if the printer only adds 10 or 15 per cent. to cost of paper.

COMPOSITION.

To be figured at 70c. per 1000 ems, and time work 60c. an hour.

Alterations to be figured separately from composition, and charged at the hour rate.

Open Advertising Matter on newspapers or programmes to be measured as 8 Point.

Standing Type, 1c. per square inch per month.

COMPOSITION VALUES ON MISCELLANEOUS FORMS.

	4 TO SHEET CAP 33 SQ. IN.	4 TO SHEET FOLIO 60 SQ. IN.	4 TO SHEET ROYAL 70 SQ. IN.
Open blanks	\$0.75	\$1.00	\$1.25
Open blanks and down rules	1.20	2.00	2.50
Labels, open	1.20	2.15	2.50
Six Point	3.30	5.80	7.00
Eight Point	1.85	3.30	4.00
Ten Point	1.20	2.15	2.50
Twelve Point	.85	1.50	1.75

COMPOSITION VALUES—Continued.

	8 TO SHEET CAP 15 8Q. IN.	8 TO SHEET FOLIO 25 8Q. IN.	8 TO SHEET ROYAL 32 8Q. IN.
Open blanks	\$.60	\$.75	\$1.00
Open blanks and down rules	1.00	1.50	1.80
Labels, open	1.00	1.50	1.80
Six Point	1.50	2.50	3.20
Eight Point	1.00	1.50	1.80
Ten Point	.70	1.00	1.20
Twelve Point	.50	.75	.85

	12 TO SHEET CAP 10 8Q. IN.	12 TO SHEET FOLIO 20 8Q. IN.	12 TO SHEET ROYAL 26 8Q. IN.
Open blanks	\$.50	\$.75	\$.75
Open blanks and down rules	.75	1.20	1.50
Labels	.75	1.20	1.50
Six Point	1.00	2.00	2.50
Eight Point	.75	1.20	1.50
Ten Point	.50	.75	1.00
Twelve Point	.50	.60	.70

	16 TO SHEET CAP 12 8Q. IN.	16 TO SHEET FOLIO 18 8Q. IN.	16 TO SHEET ROYAL 22 8Q. IN.
Open blanks	\$.50	\$.75	\$.75
Open blanks and down rules	.75	1.00	1.25
Labels	.75	1.00	1.25
Six Point	1.30	1.60	2.25
Eight Point	.75	1.00	1.25
Ten Point	.50	.65	.85
Twelve Point	.50	.60	.70

Compare figures with time; estimates to include lock-up.

PRESSWORK.

The value of presswork is a difficult problem, because there are so many different grades of work. The prices in the following tables represent the value of good work. Since the introduction of plated papers and half-tone work rates may not be large enough for the best service, but on the average of work in an office the figures ought to be considered as fair and reasonable.

Flat papers,	100	250	500	1000	ADDED 100
Double medium	\$1.75	\$2.10	\$2.60	\$3.50	\$0.18
Double cap	1.50	1.75	2.10	2.85	.13
Folio post	1.00	1.30	1.60	2.35	.13
Fiat cap	1.00	1.30	1.60	2.35	.13
Half folio	1.00	1.30	1.60	2.35	.13
Half cap	.75	.90	1.15	1.65	.08
Quarter folio, long form	1.00	1.30	1.60	2.35	.13
Quarter folio, regular	.75	.90	1.15	1.65	.08
Quarter cap	.75	.90	1.15	1.65	.08
Smaller sizes	.60	.75	.90	1.30	.06

Print and cheap book.

38 x 50	2.00	2.50	3.00	4.50	.28
36 x 48	2.00	2.50	3.00	4.25	.26
32 x 44	2.00	2.50	3.00	4.00	.24
28 x 42	2.00	2.50	3.00	3.50	.22
25 x 38	1.75	2.25	2.75	3.00	.18
22 x 32	1.75	2.25	2.75	3.00	.15
Medium and folios	1.00	1.30	1.60	2.35	.13
Half folio and caps	1.00	1.30	1.60	2.35	.10
Half cap and quarter folios	.75	.90	1.15	1.65	.08

Bookwork.

38 x 50	2.50	3.00	3.75	5.00	.30
36 x 48	2.50	3.00	3.75	4.75	.28
32 x 44	2.50	3.00	3.50	4.50	.25
28 x 42	2.50	3.00	3.50	4.00	.23
25 x 38	2.00	2.50	3.00	3.50	.20
22 x 32	2.00	2.40	2.75	3.25	.17
19 x 25	1.50	2.00	2.50	3.00	.14

Half-tone work on highly-finished or plated papers add 25 per cent. to bookwork scale.

Bronze work, double presswork.

BASIS FOR FIGURING VALUE OF PAPER.

The basis for figuring the value of paper will be 50 per cent. on the cost price. This price is to include the proportionate cost of general expense and handling in every way—the opening, cutting, and repacking and waste.

Unless there is a special determination by the customer as to the quality of papers, figures will be based on grades of book and writing papers as follows:

Print paper, 2½c., to be figured at	4½	Tub sized, 11c., to be figured at	18
Colored print, 4c., to be figured at	6	Water marked, 13c., to be figured at	20
Common book, 4c., to be figured at	6	Linen, 14c., to be figured at	21
S. & C. book, 4½c., to be figured at	7	Fine linen, 16c., to be figured at	24
S. & S. C. book, 5c., to be figured at	7½	Superfine linen, 18c., to be figured at	27
Plated book, 8c., to be figured at	12	Pure linen, 21c., to be figured at	30
Manilla, 4½c., to be figured at	6½	Crane's linens, 24c., to be figured at	35
Engine sized, 7c., to be figured at	11		

PRINTERS' VALUE OF 1000 SHEETS PAPER OF THE WEIGHT DESIGNATED AT TOP OF COLUMN.

The basis for figuring the value of paper is 50 per cent. on the cost price.

	12-LB.	14-LB.	16-LB.	18-LB.	20-LB.	22-LB.
Costing \$0.02 per lb.	\$0.75	\$0.87	\$1.00	\$1.13	\$1.25	\$1.38
Costing .02½ per lb.94	1.09	1.25	1.41	1.57	1.73
Costing .03 per lb.	1.13	1.32	1.50	1.69	1.88	2.07
Costing .03½ per lb.	1.32	1.54	1.75	1.97	2.19	2.42
Costing .04 per lb.	1.50	1.75	2.00	2.25	2.50	2.75
Costing .05 per lb.	1.88	2.18	2.50	2.82	3.13	3.45
Costing .05½ per lb.	2.06	2.41	2.75	3.10	3.44	3.78
Costing .06 per lb.	2.25	2.63	3.00	3.38	3.75	4.13
Costing .06½ per lb.	2.44	2.85	3.25	3.66	4.07	4.47
Costing .07 per lb.	2.63	3.07	3.50	3.94	4.38	4.81
Costing .07½ per lb.	2.81	3.27	3.75	4.22	4.69	5.18
Costing .08 per lb.	3.00	3.50	4.00	4.50	5.00	5.50
Costing .08½ per lb.	3.19	3.72	4.25	4.78	5.31	5.84
Costing .09 per lb.	3.38	3.94	4.50	5.06	5.63	6.19
Costing .09½ per lb.	3.56	4.15	4.75	5.34	5.94	6.53
Costing .10 per lb.	3.75	4.35	5.00	5.63	6.25	6.90
Costing .10½ per lb.	3.94	4.60	5.25	5.90	6.57	7.22
Costing .11 per lb.	4.12	4.81	5.50	6.19	6.88	7.56
Costing .11½ per lb.	4.32	5.04	5.75	6.48	7.20	7.92
Costing .12 per lb.	4.50	5.25	6.00	6.75	7.50	8.25
Costing .12½ per lb.	4.68	5.46	6.25	7.02	7.80	8.58
Costing .13 per lb.	4.88	5.70	6.50	7.32	8.13	8.94
Costing .14 per lb.	5.25	6.13	7.00	7.88	8.75	9.62
Costing .15 per lb.	5.62	6.53	7.50	8.44	9.38	10.35
Costing .16 per lb.	6.00	7.00	8.00	9.00	10.00	11.00
Costing .17 per lb.	6.38	7.44	8.50	9.56	10.62	11.68
Costing .18 per lb.	6.75	7.88	9.00	10.12	11.25	12.38
Costing .19 per lb.	7.12	8.30	9.50	10.68	11.88	13.06
Costing .20 per lb.	7.50	8.70	10.00	11.25	12.50	13.30
Costing .21 per lb.	7.88	9.20	10.50	11.80	13.14	14.44
Costing .22 per lb.	8.24	9.62	11.00	12.38	13.75	15.12
Costing .23 per lb.	8.64	10.08	11.50	12.96	14.40	15.84
Costing .24 per lb.	9.00	10.50	12.00	13.50	15.00	16.50
Costing .25 per lb.	9.36	10.92	12.50	14.04	15.60	17.16

For other weights combine or divide the figures.

American linen and similar grades: 14-lb., \$9.80; 16-lb., \$11.20; 18-lb., \$12.60; 20-lb. \$14.00.

Crane Bros'. all linen and similar goods, 500 sheets to ream: 16-lb., \$11.20; 20-lb., \$14.00; 24-lb., \$16.80.

Japanese linen and similar goods, 480 sheets to ream: 20-lb., \$14.00; 24-lb., \$17.30; 28-lb., \$18.80.

Ledger papers, per 100 sheets (Weston or Brown).

- Demy, 28-lb., \$2.15; 30-lb., \$2.40.
- Medium, 36-lb., \$3.00; 40-lb., \$3.50.
- Double cap, 36-lb., \$2.50; 40-lb., \$2.80.
- Royal, 44-lb., \$3.70. Super royal, 54-lb., \$5.00.
- Double demy, 56-lb., \$4.25.
- Double medium, 72-lb., \$6.00; 80-lb., \$7.00.

SIZES OF FLAT WRITING PAPER.

Flat Letter	10 × 16	Double Demy, narrow	16 × 42
Flat Packet or Packet Post	12 × 19	Double Demy, broad	21 × 32
Flat Foolscap or Small Cap	13 × 16	Elephant	23 × 28
Flat Cap	14 × 17	Medium	18 × 23
Crown or Crown Cap	15 × 19	Imperial	23 × 31
Double Letter	16 × 20	Double Medium, narrow	18 × 46
Demy	16 × 21	Double Medium, broad	23 × 36
Folio Post or Folio	17 × 22	Double Royal	24 × 38
Double Folio	22 × 34	Double Elephant	27 × 40
Double Cap	17 × 28	Columbier	23 × 34
Small Double Cap	16 × 26	Atlas	26 × 33
Royal, Double Packet or Packet Folio	19 × 24	Antiquarian	31 × 53
Super Royal	20 × 28	Cardboard	22 × 28

SIZES OF RULED PAPER.

	INCHES.	SHEET.		INCHES.	SHEET.
Commercial Note Heads	5½ × 8½	½ Folio	Bill Heads—Thirds, 1500 to		
Hotel Note Heads	5½ × 11	¼ Folio	Ream	8½ × 9½	¼ D. Cap
Packet Note Heads	5½ × 9	½ Medium	Bill Heads—Halves, 1000 to		
Royal Packet Note Heads	6 × 9½	½ Royal	Ream	8½ × 14	¼ Cap
Demy Letter Heads	8 × 10½	¼ Demy	Regular Statements	5½ × 8½	¼ Folio
Folio Letter Heads	8½ × 11	¼ Folio	Hotel Statements	5½ × 11	¼ Folio
Memorandum Heads	5½ × 8½	¼ Folio	Head and Tail Statements	5½ × 8½	¼ Folio
Bill Heads—Sixes, 3000 to			Gem Statements	3½ × 5½	
Ream	8½ × 4¾	¼ Cap	Infant Statements	4½ × 5½	
Bill Heads—Quarters, 2000			Square Statements	5½ × 5½	
to Ream	8½ × 7	¼ Cap	Yankee Statements	3½ × 8½	

REGULAR ENVELOPE SIZES.

BANK.					PAMPHLET.	
No. 6	4½ × 6½	No. 9	3½ × 8½		No. 2	6½ × 10
" 7	4½ × 7½	" 10	4½ × 9½		" 3	6½ × 10½
" 8	5 × 7½	" 11	4½ × 10¾			
		" 12	4½ × 11			
		" 14	5 × 11½			
BARONIAL.					PAY.	
No. 4	3½ × 4½				No. 2	2½ × 4½
" 5	4½ × 5½					
		COIN.			PHOTOGRAPH.	
		OPEN END.			OPEN END.	
COMMERCIAL.		No. 3	2½ × 4½		Cabinet	4½ × 7½
No. 3	2½ × 4½	" 5	2½ × 5½		Wide Imperial Cabinet	5½ × 7½
" 4	2½ × 5½	" 7	3½ × 5½			
" 5	3½ × 5½				PORTFOLIO.	
" 6	3½ × 6	No. 1	1½ × 2½		No. 1	5½ × 8½
" 6½	3½ × 6½	" 2	2½ × 3½		" 2	6½ × 8½
" 7	3½ × 6½	" 3	2½ × 3½		" 3	6½ × 9½

SIZES OF THE UNTRIMMED LEAF.

Folio	12 × 19	inches
Quarto, 4to	9½ × 12	"
Imperial 8vo or 8° (octavo)	8½ × 11½	"
Super Royal 8vo or 8° (octavo)	7 × 11	"
Royal 8vo or 8° (octavo)	6½ × 10	"
Medium 8vo or 8° (octavo)	6 × 9½	"
Demy 8vo or 8° (octavo)	5½ × 8½	"
Medium 12mo or 12° (duodecimo)	5½ × 7½	"
Medium 16mo or 16° (sexdecimo)	4½ × 6½	"
Cap 8vo or 8° (octavo)	4½ × 7	"
Medium 18mo or 18° (octodecimo)	4 × 6½	"
Super Royal 32mo (tricesimo secundo)	3½ × 5½	"

ADVERTISING PROGRAMMES.

Composition on advertising programmes is properly rated as 8 Point, and if the programme itself is set in 6 Point an extra charge should be made of \$1.00.

Folding not included in following figures.

Four Pages—Quarter sheet of 22 x 32.

	PRINT PAPER.	BOOK PAPER.
100 copies, 13 ems. 3 columns to page, composition, per page, \$4.30	\$18.25	\$18.30
Added 100 copies26	.31
Added 1,000 copies	2.50	3.00

Four Pages—Quarter sheet of 24 x 36.

100 copies, 15 ems. 3 columns to page, composition, per page, \$5.60	23.50	23.60
Added 100 copies27	.32
Added 1,000 copies	2.60	3.10

Four Pages—Quarter sheet of 25 x 38.

100 copies, 16 ems. 3 columns to page, composition, per page, \$6.10	25.55	25.55
Added 100 copies35	.35
Added 1,000 copies	3.40	3.40

Four Pages—Quarter sheet of 26 x 40.

100 copies, 13 ems. 4 columns to page, composition, per page, \$7.50	31.20	..
Added 100 copies29	..
Added 1,000 copies	2.75	..

Four Pages—Quarter sheet of 28 x 42.

100 copies, 13 ems. 4 columns to page, composition, per page, \$8.10	33.60	33.70
Added 100 copies30	.38
Added 1,000 copies	2.80	3.70

Half the size, at two-thirds the rate.

Advertising matter on newspapers or programmes to be measured as 8 Point.

Alterations to be figured separately from composition and charged at the hour rate of 60 cents.

BY-LAWS, CONSTITUTIONS AND SMALL BOOKLETS.

Size of printed page, 3½ x 5½ inches, trimmed, 32 to sheet of 22 x 32 40-lb. book paper and 50-lb. cover paper.

	8 POINT TYPE.	7 POINT TYPE.	6 POINT TYPE.
8 pages (15 x 27 ems) and cover	\$ 7.75	\$ 9.40	\$11.65
Added 100 copies55	.55	.55
500 copies	9.95	11.60	13.85
1000 copies	12.70	14.35	16.60
Added 1000 copies	5.50	5.50	5.50
16 pages (15 x 27 ems) and cover	13.00	16.30	20.80
Added 100 copies75	.75	.75
500 copies	16.00	19.30	23.80
1000 copies	19.75	23.05	27.55
Added 1000 copies	7.50	7.50	7.50
24 pages (15 x 27 ems) and cover	19.30	24.25	31.00
Added 100 copies	1.05	1.05	1.05
32 pages (15 x 27 ems) and cover	25.00	31.60	41.00
Added 100 copies	1.30	1.30	1.30

ABSTRACTS OF TITLE.

Printed on half sheet of 16-lb. flat cap, usually set in 10 Point type, hanging indention, one full page, with backing :

100 copies (composition, \$4.00)	\$5.30
Additional 100 copies40
Additional pages, 100 copies	4.05
Added 100 copies40

Printed on ruled paper, separating descriptions, add \$1.00 for each page to above prices.

Cover and backing, add \$2.00.

BRIEFS AND PAPER BOOKS.

\$1.00 per printed page, net, for all under 100 pages; over 100 pages, 90 cents per page, net.

DODGERS, HAND-BILLS, PROGRAMMES, ETC.

ON PRINT AND BOOK PAPER.

On 3-cent paper. (24 × 36 inches, 30-lb.)

	100	250	500	1000	ADDED 1000
3 to a sheet, paper \$0.90 per thousand	\$4.50	\$5.00	\$5.50	\$6.75	\$2.40
4 to a sheet, paper .68 per thousand	4.00	4.50	5.00	6.00	2.10
6 to a sheet, paper .45 per thousand	3.25	3.65	4.10	4.90	1.80
8 to a sheet, paper .34 per thousand	2.45	2.75	3.15	3.80	1.40
10 to a sheet, paper .27 per thousand	2.25	2.60	2.85	3.50	1.30
12 to a sheet, paper .23 per thousand	1.90	2.20	2.50	3.10	1.20
16 to a sheet, paper .17 per thousand	1.75	1.95	2.15	2.60	.90
24 to a sheet, paper .12 per thousand	1.20	1.40	1.55	2.00	.70

On 4-cent paper (24 × 36 inches, 40-lb.)

	100	250	500	1000	ADDED 1000
3 to a sheet, paper \$1.60 per thousand	4.60	5.20	5.85	7.00	3.10
4 to a sheet, paper 1.20 per thousand	4.10	4.60	5.55	6.45	2.60
6 to a sheet, paper .80 per thousand	3.35	3.70	4.20	5.35	2.15
8 to a sheet, paper .60 per thousand	2.55	2.80	3.25	4.10	1.70
10 to a sheet, paper .48 per thousand	2.35	2.65	2.95	3.70	1.50
12 to a sheet, paper .40 per thousand	2.00	2.25	2.55	3.25	1.40
16 to a sheet, paper .30 per thousand	1.80	2.00	2.24	2.75	1.05
24 to a sheet, paper .20 per thousand	1.30	1.40	1.60	2.00	.80

The 4c. paper will represent the value of colored prints.

Blue or green ink will add for the first 100 copies \$1.00, and for subsequent 100s, in sizes above sixes, 10c. per 100. On sixes and eights, subsequent 100s at 5c.

Bright red ink will add for the first 100 copies \$1.25, and for subsequent 100s, in sizes above sixes, 20c. per 100. On sixes and eights, subsequent 100s at 10c.

POSTERS AND SHOW-BILLS.

Using 40-lb. paper, 28 × 42 inches, costing 4c., the value of 100 sheets being 50c.

Whole sheet.

	100	250	500	1000	ADDED 1000
Black ink	\$5.10	\$6.50	\$ 8.75	\$13.00	\$0.90
Red or blue ink	6.10	7.75	11.50	16.00	1.10
In two colors	7.80	9.90	13.40	20.40	1.40

Half sheet.

	100	250	500	1000	ADDED 1000
Black ink	4.30	5.05	6.30	8.80	.50
Red or blue ink	5.30	6.20	7.70	10.70	.60
In two colors	7.00	8.35	10.60	15.00	.90

Third sheet.

	100	250	500	1000	ADDED 1000
Black ink	3.70	4.25	5.10	6.85	.35
Red or blue ink	4.70	5.30	6.30	8.30	.40
In two colors	6.20	7.25	8.80	12.00	.65

Quarter sheet.

	100	250	500	1000	ADDED 1000
Black ink	3.15	3.60	4.35	5.85	.30
Red or blue ink	4.15	4.70	5.55	7.30	.35
In two colors	5.50	6.35	7.75	10.50	.55

The most effective plain posters are printed on yellow paper, the value of paper being 80c. per 100 full sheets.

On 24 × 36 paper the difference is so slight, except in large quantities, that the same price should prevail. In 1000 orders a discount of 10 per cent. may be made.

DELEGATE OR NOMINATION TICKETS.

For conventions in separate lots of 500.

500	1000	1500	2000	ADDED 1000
\$1.25	\$1.50	\$2.00	\$2.25	\$1.00

HALF-LETTER OR QUARTER-FOLIO CIRCULARS.

No form rated at less than \$1.00. The figures in this table are based on 10 Point and \$2.00 for composition. The value of a full page of 12 Point is \$1.50; 10 Point, \$2.00; 8 Point, \$3.00; 6 Point, \$4.00. The difference should be added or deducted from the gross figures.

20-lb. stock.

	100	250	500	1000	ADDED 100
8-cent paper, \$1.20 per thousand	\$2.85	\$3.20	\$3.75	\$4.85	\$0.20
10-cent paper, 1.50 per thousand	2.90	3.30	3.90	5.15	.23
12-cent paper, 1.80 per thousand	2.95	3.35	4.05	5.45	.26
14-cent paper, 2.10 per thousand	2.95	3.40	4.20	5.75	.29
16-cent paper, 2.40 per thousand	3.00	3.50	4.35	6.05	.32
18-cent paper, 2.70 per thousand	3.05	3.55	4.50	6.35	.35
20-cent paper, 3.00 per thousand	3.05	3.65	4.65	6.65	.38

24-lb. stock will add for paper for each 1000 copies—on 8c. paper 25c., 10c. paper 31c., 12c. paper 37c., 14c. paper 44c., 16c. paper 50c., 18c. paper 56c., 20c. paper 62c.

Printing front and back, different forms, add for composition and 5c. per 100 additional for presswork.

Figure on 10c. paper and 20-lb. stock, unless requested otherwise.

FOLDED NOTE CIRCULARS.

Using quarter sheet demy or folio. The figures are based on 10 Point and \$1.00 for each page of composition. The value of a full page of 12 Point is 75c.; 8 Point, \$1.50; 6 Point, \$2.00. The difference should be added or deducted from the gross figures.

One page, folded, 20-lb. stock.

	100	250	500	1000	ADDED 100
8-cent paper, \$1.20 per thousand	\$2.00	\$2.30	\$2.85	\$4.00	\$0.20
10-cent paper, 1.50 per thousand	2.05	2.40	3.00	4.30	.23
12-cent paper, 1.80 per thousand	2.10	2.45	3.15	4.60	.26
14-cent paper, 2.10 per thousand	2.15	2.50	3.30	4.90	.29
16-cent paper, 2.40 per thousand	2.20	2.60	3.45	5.20	.32
18-cent paper, 2.70 per thousand	2.25	2.65	3.60	5.50	.35
20-cent paper, 3.00 per thousand	2.30	2.70	3.75	5.80	.38

Two pages, folded, 20-lb. stock.

8-cent paper	2.00	3.30	3.85	5.00	.25
10-cent paper	3.05	3.40	4.00	5.30	.28
12-cent paper	3.10	3.45	4.15	5.60	.31
14-cent paper	3.15	3.50	4.30	5.90	.34
16-cent paper	3.20	3.60	4.45	6.20	.37
18-cent paper	3.25	3.65	4.60	6.50	.40
20-cent paper	3.30	3.70	4.75	6.80	.43

Three pages, folded, 20-lb. stock.

8-cent paper	4.00	4.30	4.85	6.00	.25
10-cent paper	4.05	4.40	5.00	6.30	.28
12-cent paper	4.10	4.45	5.15	6.60	.31
14-cent paper	4.15	4.50	5.30	6.90	.34
16-cent paper	4.20	4.60	5.45	7.20	.37
18-cent paper	4.25	4.65	5.60	7.50	.40
20-cent paper	4.30	4.70	5.75	7.70	.43

Four pages, folded, 20-lb. stock.

8-cent paper	5.00	5.30	5.85	7.00	.25
10-cent paper	5.05	5.40	6.00	7.30	.28
12-cent paper	5.10	5.45	6.15	7.60	.31
14-cent paper	5.15	5.50	6.30	7.90	.34
16-cent paper	5.20	5.60	6.45	8.20	.37
18-cent paper	5.25	5.65	6.60	8.50	.40
20-cent paper	5.30	5.70	7.75	8.80	.43

For difference in weight of stock, see half-letter or quarter-folio circulars.

The above figures include folding one fold.

Figure on 10c. paper and 20-lb. stock, unless requested otherwise.

HALF NOTE OR EIGHTH FOLIO CIRCULARS.

No form rated less than 50c. for composition. The figures in this table are based on 10 Point and \$1.00 for composition. The value of a full page of 12 Point is 75c.; 10 Point, \$1.00; 8 Point, \$1.50; 6 Point, \$2.00. The difference should be added or deducted from the gross figures.

20-lb. stock.

	100	250	500	1000	ADDED 100
8-cent paper, \$0.60 per thousand	\$1.65	\$1.90	\$2.20	\$2.90	\$0.12
10-cent paper, .75 per thousand	1.70	2.00	2.30	3.05	.14
12-cent paper, .90 per thousand	1.70	2.05	2.35	3.20	.15
14-cent paper, 1.05 per thousand	1.70	2.10	2.45	3.35	.16
16-cent paper, 1.20 per thousand	1.75	2.10	2.50	3.50	.18
18-cent paper, 1.35 per thousand	1.80	2.10	2.60	3.65	.19
20-cent paper, 1.50 per thousand	1.85	2.15	2.70	3.80	.21

Printing front and back, add for composition only.

24-lb. stock will add for paper for each 1000 copies—on 8c. paper 12c., 10c. paper 15c., 12c. paper 19c., 14c. paper 21c., 16c. paper 25c., 18c. paper 28c., 20c. paper 31c.

FOLDED LETTER CIRCULARS.

Using half sheet demy or folio. The figures are based on 10 Point and \$2.00 for each page of composition. The value of a full page of 12 Point is \$1.50; 8 Point, \$3.00; 6 Point, \$4.00. The difference should be added or deducted from the gross figures.

One page, folded, 20-lb. stock.

	100	250	500	1000	ADDED 100
8-cent paper, \$2.40 per thousand	\$3.25	\$3.90	\$4.80	\$6.75	\$0.37
10-cent paper, 3.00 per thousand	3.30	4.05	5.10	7.35	.43
12-cent paper, 3.60 per thousand	3.35	4.20	5.40	7.95	.49
14-cent paper, 4.20 per thousand	3.40	4.35	5.70	8.55	.55
16-cent paper, 4.80 per thousand	3.45	4.50	6.00	9.15	.61
18-cent paper, 5.40 per thousand	3.50	4.65	6.30	9.75	.67
20-cent paper, 6.00 per thousand	3.55	4.80	6.60	10.35	.73

Two pages, folded, 20-lb. stock.

8-cent paper	5.25	5.90	6.80	8.75	.37
10-cent paper	5.30	6.05	7.10	9.35	.43
12-cent paper	5.35	6.20	7.40	9.95	.49
14-cent paper	5.40	6.35	7.70	10.55	.55
16-cent paper	5.45	6.50	8.00	11.15	.61
18-cent paper	5.50	6.65	8.30	11.75	.67
20-cent paper	5.55	6.80	8.60	12.35	.73

Three pages, folded, 20-lb. stock.

8-cent paper	7.25	7.90	8.80	10.75	.37
10-cent paper	7.30	8.05	9.10	11.35	.43
12-cent paper	7.35	8.20	9.40	11.95	.49
14-cent paper	7.40	8.35	9.70	12.55	.55
16-cent paper	7.45	8.50	10.00	13.15	.61
18-cent paper	7.50	8.65	10.30	13.75	.67
20-cent paper	7.55	8.80	10.60	14.35	.73

Four pages, folded, 20-lb. stock.

8-cent paper	9.25	9.90	10.80	12.75	.37
10-cent paper	9.30	10.05	11.10	13.35	.43
12-cent paper	9.35	10.20	11.40	13.95	.49
14-cent paper	9.40	10.35	11.70	14.55	.55
16-cent paper	9.45	10.50	12.00	15.15	.61
18-cent paper	9.50	10.65	12.30	15.75	.67
20-cent paper	9.55	10.80	12.60	16.35	.73

The above figures include folding one fold.

24-lb. stock will add for paper for each 1000 copies—on 8c. paper 50c., 10c. paper 62c., 12c. paper 75c., 14c. paper 88c., 16c. paper \$1.00, 18c. paper \$1.12, 20c. paper \$1.25.

Figure on 10c. paper and 20-lb. stock, unless requested otherwise.

CARD SCALE.

This is the scale referred to in the Price List of Business Cards on opposite page. The scale is based on 22 x 28 inch cardboard.

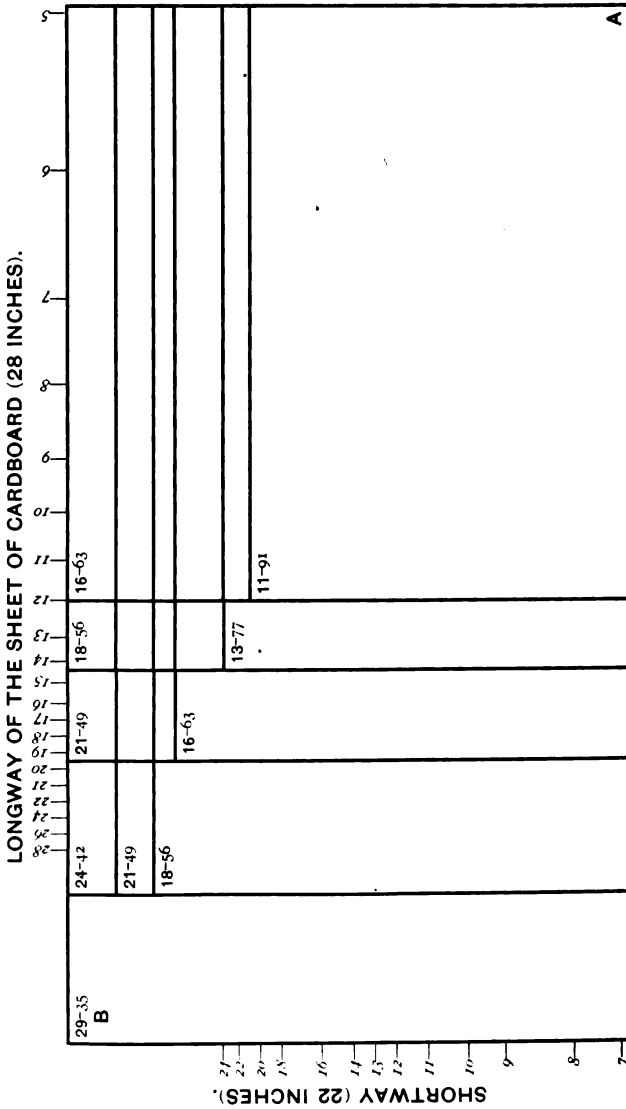

EXPLANATION.—The first figures in Gothic in the upper left-hand corner of each size indicate the number of sheets required for 1000 cards of that size. The figures in Roman, after the dash, indicate the number of cards that can be cut from one sheet of cardboard, *measuring from the lower right-hand corner of the scale (A).*
 The Italic figures outside the scale indicate the number of cuts to a sheet for any size of card not exceeding the size of scale, measuring from the upper left-hand corner (B); and the number of cards procurable from a sheet may be ascertained by multiplying the shortwise and longwise numbers. Example: If a card measures from B longwise to 8 and from B shortwise to 8, the number of cards procurable from one full-sized sheet of 22 x 28 inch card will be 64.

CARD SCALE.

The card scale on opposite page agrees approximately with the card scales issued by various dealers in cardboard. There is no standard scale. Printers should procure the card scale of the dealers who supply them with cards. The "Convenient Card Scale and Table of Prices," compiled by Mr. C. F. Pedrick and copyrighted and issued to the trade by Irwin N. Megargee & Co., dealers in cards, 12 S. Sixth St., Philadelphia, will save printers a great deal of time and insure accuracy in estimating. This valuable scale shows at a glance: (1) Cost per 1000 cards of any size after being cut from any kind or quality of board, ranging in list price from \$1.00 to \$15.00 per 100 sheets, 22 x 28 inches; (2) Which way of the sheet a card of any size will cut to the best advantage; (3) Number of sheets of 22 x 28 inches cardboard required to cut 1000 cards of any size. This scale is printed on a large sheet of bond paper in two colors, and applicants for it should inclose ten cents in postage stamps.

BUSINESS CARDS.

The sizes and figures given for business cards such as 11-91, 50c. stand for 11 full sheets each cutting 91 cards, and the value, including cutting of 1000 of such cards, is 50 cents. On the general rule that all the prices given in these tables have a margin of profit the stock figures represent an addition to the cost of 50 per cent.

Costing \$1.60 for 100 full sheets.

	100	250	500	1000	ADDED 100
11-91, \$0.50 per thousand	\$1.00	\$1.20	\$1.50	\$2.00	\$0.11
13-77, .56 per thousand	1.05	1.25	1.60	2.25	.12
16-63, .63 per thousand	1.15	1.40	1.70	2.30	.13
18-56, .68 per thousand	1.20	1.45	1.80	2.50	.14
21-49, .75 per thousand	1.25	1.50	1.85	2.55	.15
24-42, .82 per thousand	1.30	1.60	1.95	2.70	.15
29-35, .95 per thousand	1.40	1.65	2.10	2.85	.16

Costing \$2.00 for 100 full sheets.

	100	250	500	1000	ADDED 100
11-91, \$0.58 per thousand	1.00	1.20	1.50	2.10	0.12
13-77, .64 per thousand	1.05	1.25	1.60	2.25	.13
16-63, .75 per thousand	1.15	1.40	1.75	2.45	.14
18-56, .79 per thousand	1.20	1.45	1.85	2.55	.15
21-49, .88 per thousand	1.25	1.60	1.95	2.70	.16
24-42, .97 per thousand	1.30	1.65	2.00	2.80	.16
29-35, 1.12 per thousand	1.40	1.70	2.20	3.10	.18

Costing \$3.00 for 100 full sheets.

	100	250	500	1000	ADDED 100
11-91, \$0.75 per thousand	1.15	1.35	1.55	2.25	0.14
13-77, .83 per thousand	1.30	1.55	1.70	2.45	.15
16-63, .97 per thousand	1.45	1.70	1.90	2.75	.16
18-56, 1.01 per thousand	1.45	1.75	1.95	2.85	.17
21-49, 1.25 per thousand	1.45	1.80	2.00	2.95	.18
24-42, 1.33 per thousand	1.75	2.05	2.35	3.35	.20
29-35, 1.55 per thousand	1.75	2.10	2.45	3.60	.22

Costing \$4.00 for 100 full sheets.

	100	250	500	1000	ADDED 100
11-91, \$0.91 per thousand	1.20	1.45	1.85	2.65	0.15
13-77, 1.03 per thousand	1.30	1.55	2.00	2.90	.16
16-63, 1.21 per thousand	1.50	1.80	2.30	3.30	.18
18-56, 1.33 per thousand	1.50	1.85	2.35	3.40	.19
21-49, 1.51 per thousand	1.50	1.95	2.40	3.55	.21
24-42, 1.69 per thousand	1.75	2.10	2.60	3.80	.22
29-35, 1.99 per thousand	1.80	2.20	2.90	4.25	.24

Round-corner cards will add 50c. for each 1000, added to the foregoing figures.

For cheap entertainment cards use \$2.00 scale. For business cards use the \$4.00 scale, unless specially requested for another grade.

In colored ink, add 50c. to the gross price for any number under 1000, and 10c. for added 1000. For two forms, two colors, add \$1.00 to the gross price; presswork scale for second form.

Cards, backed with another form on cheap grades, add \$1.00, and print both sides at once. On grades on this page make separate presswork and charge 50c. and presswork scale to gross price.

BUSINESS CARDS—Continued.

(See Card Scale on page 1006.)

The finer grades of business cards should be rated somewhat higher than common grades, on account of the extra care in composition and presswork.

Costing \$5.00 per 100 full sheets.

	100	250	500	1000	ADDED 100
11—91, \$1.02 per thousand	\$1.30	\$1.60	\$1.80	\$2.70	\$0.16
13—77, 1.17 per thousand	1.30	1.65	2.10	3.10	.18
16—63, 1.39 per thousand	1.50	1.70	2.35	3.45	.20
18—56, 1.54 per thousand	1.50	1.85	2.40	3.55	.21
21—49, 1.76 per thousand	1.55	1.95	2.60	3.90	.24
24—42, 1.98 per thousand	1.80	2.20	3.00	4.40	.26
29—35, 2.75 per thousand	1.85	2.35	3.10	4.70	.29

Costing \$6.00 per 100 full sheets.

	100	250	500	1000	ADDED 100
11—91, \$1.24 per thousand	1.30	1.60	2.00	2.90	.15
13—77, 1.42 per thousand	1.35	1.70	2.25	3.35	.21
16—63, 1.69 per thousand	1.50	1.80	2.45	3.65	.23
18—56, 1.87 per thousand	1.55	1.90	2.60	3.90	.25
21—49, 2.14 per thousand	1.55	2.00	2.70	4.15	.27
24—42, 2.41 per thousand	1.85	2.25	3.15	4.75	.30
29—35, 2.86 per thousand	1.90	2.45	3.35	5.15	.35

Costing \$7.00 per 100 full sheets.

	100	250	500	1000	ADDED 100
11—91, \$1.40 per thousand	1.35	1.85	2.10	3.15	.20
13—77, 1.61 per thousand	1.40	1.90	2.30	3.50	.22
16—63, 1.93 per thousand	1.55	2.00	2.65	4.00	.25
18—56, 2.14 per thousand	1.60	2.10	2.70	4.15	.27
21—49, 2.41 per thousand	1.65	2.20	2.90	4.50	.30
24—42, 2.77 per thousand	1.90	2.30	3.25	5.00	.34
29—35, 3.29 per thousand	2.00	2.50	3.50	5.50	.39

Costing \$8.00 per 100 full sheets.

	100	250	500	1000	ADDED 100
11—91, \$1.57 per thousand	1.35	1.90	2.20	3.30	.22
13—77, 1.81 per thousand	1.45	1.95	2.40	3.70	.24
16—63, 2.17 per thousand	1.60	2.10	2.75	4.25	.28
18—56, 2.41 per thousand	1.65	2.20	2.85	4.45	.30
21—49, 2.77 per thousand	1.70	2.30	3.10	4.70	.34
24—42, 3.13 per thousand	1.95	2.40	3.45	5.25	.37
29—35, 3.73 per thousand	2.10	2.60	3.70	5.75	.43

Above prices to govern professional cards.

In colored ink, add 50c. to the gross price for any number under 1000, and 10c. for added 1000. For two forms, two colors, add \$1.00 to the gross price; presswork scale for second form.

Cards backed with another form on cheap grades, add \$1.00, and print both sides at once. On grades on this page make separate presswork and charge 50c. and presswork scale on gross price.

ANNOUNCEMENT AND WEDDING INVITATIONS.

Full note, 80-lb., satin wove, with inside and outside envelopes, fine script type.

25 copies, stock \$0.60	\$2.50	100 copies, stock \$2.40	\$5.50
50 copies, stock 1.20	3.50	Added 100 copies	4.00
75 copies, stock 1.80	4.50		

VISITING AND WEDDING CARDS.

50 cards and printing	\$1.00	200 cards and printing	\$1.50
100 cards and printing	1.25		

ENGRAVED INVITATIONS AND CARD PLATES.

25 invitations on full note	\$ 9.00	50 cards and plate (name only)	\$1.75
50 invitations on full note	10.00	100 cards and plate (name only)	2.00
75 invitations on full note	11.00	Address or additional lines, each50
100 invitations on full note	12.00	100 cards from plate	1.25
Additional 100	6.00	Additional 10080

ANNOUNCEMENT CARDS—BARONIAL.

Size 25—3½ × 4¾ inches—	100	250	500	1000	ADDED 100
5-cent stock, \$0.20 per hundred	\$1.75	\$2.00	\$2.65	\$4.00	\$0.26
6-cent stock, .23 per hundred	1.85	2.15	2.90	4.55	.31
7-cent stock, .26 per hundred	1.95	2.20	3.10	4.95	.35
8-cent stock, .30 per hundred	2.00	2.25	3.15	5.05	.36

Size 36—4 × 5 inches—	100	250	500	1000	ADDED 100
5-cent stock, \$0.30 per hundred	1.90	2.25	3.15	5.05	.36
6-cent stock, .35 per hundred	2.00	2.35	3.40	5.55	.41
7-cent stock, .40 per hundred	2.10	2.50	3.65	6.05	.46
8-cent stock, .45 per hundred	2.20	2.60	3.90	6.55	.51

Baronial envelopes, without printing, No. 4, for size 25, cream or white, \$1.60 per 1000; and No. 5, for size 36, at \$2.00 per 1000. Linen XX, No. 4, \$1.80 per 1000, and No. 5, \$2.10 per 1000.

BALL AND DANCE PROGRAMMES.

Size 3½ × 4¾, when folded, cuts 16 to a sheet of card stock.

Value of Completed Work (Four Pages).

ITEMS.	50	100	200	300
Card stock	\$0.25	\$0.50	\$1.00	\$1.50
Composition	2.40	2.40	2.40	2.40
Presswork and scoring	1.15	1.35	1.60	1.90
Totals	\$3.80	\$4.25	\$5.00	\$5.80
Tassels and stringing60	1.00	1.75	2.50
Pencils75	1.50	3.00	4.00
Totals	\$5.15	\$6.75	\$9.75	\$12.30

Colored ink will add \$1.00 to any of these prices. In two colors, add \$2.00 to above values.

If you use fancy programmes, increase the price, adding the list value of the programme to be used; the card stock charged for being equal to the expense of inserts and any additional forms of presswork on the programme.

LARGE CARDS OR POSTER ANNOUNCEMENTS.

The card stock in the following prices represents a cost value of \$2.50 per 100 full sheets.

BLACK INK.

Card Board 22 × 28—	100	250	500	1000	ADDED 100
Eighth sheet, stock \$0.45 per hundred	\$2.95	\$3.75	\$ 5.10	\$ 7.85	\$0.55
Quarter sheet, stock .90 per hundred	3.90	5.40	7.90	12.90	1.00
Third sheet, stock 1.20 per hundred	5.20	7.30	10.80	17.80	1.40
Half sheet, stock 1.75 per hundred	6.25	9.25	14.25	24.25	2.00
Whole sheet, stock 3.50 per hundred	9.50	15.10	24.50	43.25	3.75

If in colored ink, add for first 100, \$1.00, and 5 cents for added 100 up to quarter sheets, and 10 cents for sizes over quarter sheets.

TWO COLORS OF INK.

	100	250	500	1000	ADDED 100
Eighth sheet	\$4.50	\$ 5.70	\$ 7.70	\$11.70	\$0.80
Quarter sheet	5.50	7.35	10.50	16.75	1.25
Third sheet	7.00	9.60	14.00	22.75	1.75
Half sheet	8.00	12.50	21.90	33.65	2.35
Whole sheet	12.00	18.30	28.80	49.80	4.20

BLOTTING PADS.

	12s	16s	20s
60-lb. stock at \$0.10 per lb., 1,000	4 × 9½	4¾ × 6	3¾ × 6
Added 1,000	\$3.95	\$3.55	\$3.30
80-lb. stock at \$0.10 per lb., 1,000	2.35	1.95	1.70
Added 1,000	4.45	3.90	3.60
Enamelled blotter, 1,000	2.85	2.30	2.00
Added 1,000	5.90	5.00	4.50
	4.30	3.45	2.90

In colored ink add \$2.00 for any number under 5000. Over 5000, add for colored ink 40c. per 1000.

BILL HEADS.

The usual sizes of stock-ruled bill heads are 6s, 4s, 3s and 2s of flat cap. The prices given are for ruled papers, costing the printer the prices named, at the rate per pound. If special ruling is required, the full expense of ruling must be added to the figures, because the grade of paper used would represent the value without ruling.

8-cent paper.

	100	250	500	1000	ADDED 100
14-lb., 6s, \$0.56 per thousand	\$1.55	\$1.75	\$2.05	\$2.65	\$0.12
14-lb., 4s, .84 per thousand	1.60	1.80	2.15	2.95	.15
14-lb., 3s, 1.12 per thousand	1.70	1.90	2.35	3.20	.18
14-lb., 2s, 1.68 per thousand	1.75	2.00	2.65	3.80	.24

10-cent paper.

14-lb., 6s, \$0.70 per thousand	1.55	1.80	2.10	2.80	.14
14-lb., 4s, 1.05 per thousand	1.60	1.85	2.30	3.15	.17
14-lb., 3s, 1.40 per thousand	1.65	1.95	2.45	3.50	.21
14-lb., 2s, 2.10 per thousand	1.70	2.10	2.80	4.20	.28
16-lb., 6s, .80 per thousand	1.60	1.80	2.15	2.90	.15
16-lb., 4s, 1.20 per thousand	1.65	1.90	2.35	3.30	.19
16-lb., 3s, 1.60 per thousand	1.70	2.00	2.55	3.70	.23
16-lb., 2s, 2.40 per thousand	1.75	2.20	2.95	4.50	.31

12-cent paper.

14-lb., 6s, \$0.84 per thousand	1.60	1.80	2.15	2.95	.15
14-lb., 4s, 1.26 per thousand	1.65	1.90	2.40	3.35	.20
14-lb., 3s, 1.68 per thousand	1.70	2.00	2.60	3.80	.24
14-lb., 2s, 2.52 per thousand	1.75	2.25	3.00	4.60	.32
16-lb., 6s, .96 per thousand	1.60	1.85	2.25	3.05	.17
16-lb., 4s, 1.44 per thousand	1.65	1.95	2.45	3.55	.21
16-lb., 3s, 1.92 per thousand	1.70	2.10	2.70	4.00	.26
16-lb., 2s, 2.88 per thousand	1.80	2.30	3.20	5.00	.36

14-cent paper.

14-lb., 6s, \$1.00 per thousand	1.60	1.85	2.25	3.10	.17
14-lb., 4s, 1.47 per thousand	1.65	1.95	2.50	3.55	.22
14-lb., 3s, 1.95 per thousand	1.70	2.10	2.75	4.05	.27
14-lb., 2s, 2.94 per thousand	1.80	2.35	3.20	5.05	.36
16-lb., 6s, 1.13 per thousand	1.60	1.90	2.30	3.20	.18
16-lb., 4s, 1.68 per thousand	1.65	2.00	2.60	3.80	.24
16-lb., 3s, 2.25 per thousand	1.75	2.15	2.90	4.35	.30
16-lb., 2s, 3.36 per thousand	1.85	2.45	3.45	5.45	.41

Assorted 1000s, use the 1000 price for each size, cutting off the right-hand figure, giving the price per 100.

Give the figures for 12c. ruled stock and 14-lb. weight, unless specially requested for other grades.

MONTHLY STATEMENTS.

Stock-ruled statements are generally made from 20-lb. or 24-lb. folio, and have various designations. The regular size, 8s of folio, is $5\frac{1}{2} \times 8\frac{1}{2}$ inches; square statements, 12s of folio, $5\frac{3}{4} \times 5\frac{1}{2}$ inches; yankee statements, 12s of folio, $3\frac{1}{2} \times 8\frac{1}{2}$ inches; infant statements, 16s of folio, $4\frac{1}{4} \times 5\frac{1}{2}$ inches; and gem statements, 18s of folio, $3\frac{1}{2} \times 5\frac{3}{4}$ inches.

10-cent paper, 20-lb. stock.

	100	250	500	1000	ADDED 100
8s, regular, \$0.75 per thousand	\$1.25	\$1.70	\$2.00	\$2.75	\$0.14
12s, square or yankee, .80 per thousand	1.25	1.60	1.85	2.50	.11
16s, infant, .85 per thousand	1.25	1.50	1.80	2.40	.10
18s, gem, .84 per thousand	1.25	1.50	1.80	2.38	.09

10-cent paper, 24-lb. stock.

8s, regular \$0.90 per thousand	1.30	1.70	2.05	2.90	.15
12s, square or yankee, .90 per thousand	1.30	1.60	1.90	2.60	.12
16s, infant, .95 per thousand	1.30	1.55	1.85	2.45	.11
18s, gem, .90 per thousand	1.30	1.55	1.80	2.40	.10

MONTHLY STATEMENTS—Continued.

12-cent paper, 20-lb. stock.		100	250	500	1000	ADDED 100
8s, regular,	\$0.90 per thousand	\$1.30	\$1.70	\$2.05	\$2.90	\$0.15
12s, square or yankee,	.60 per thousand	1.30	1.60	1.90	2.60	.12
16s, infant,	.50 per thousand	1.30	1.55	1.85	2.45	.11
18s, gem,	.40 per thousand	1.30	1.55	1.80	2.40	.10

12-cent paper, 24-lb. stock.		100	250	500	1000	ADDED 100
8s, regular,	\$1.08 per thousand	1.35	1.75	2.15	3.10	.17
12s, square or yankee,	.72 per thousand	1.35	1.65	1.95	2.70	.13
16s, infant,	.54 per thousand	1.35	1.60	1.90	2.55	.12
18s, gem,	.48 per thousand	1.35	1.60	1.85	2.50	.11

14-cent paper, 20-lb. stock.		100	250	500	1000	ADDED 100
8s, regular,	\$1.05 per thousand	1.35	1.75	2.15	3.10	.17
12s, square or yankee,	.70 per thousand	1.35	1.65	1.95	2.70	.13
16s, infant,	.53 per thousand	1.35	1.60	1.90	2.55	.11
18s, gem,	.47 per thousand	1.35	1.60	1.85	2.50	.11

14-cent paper, 24-lb. stock.		100	250	500	1000	ADDED 100
8s, regular,	\$1.26 per thousand	1.40	1.80	2.25	3.25	.19
12s, square or yankee,	.84 per thousand	1.40	1.65	2.00	2.85	.15
16s, infant,	.63 per thousand	1.40	1.60	1.95	2.65	.12
18s, gem,	.56 per thousand	1.40	1.60	1.90	2.55	.12

Use 12c. paper and 20-lb. stock, unless specially requested to furnish some other grade.

LETTER HEADS.

Usually printed on quarter-sheet folio, the grades of paper differing very materially; but, with the designation of cost values of the stock, the figures cover all the grades from a cheap writing to a first-class linen paper. The prices are maximum, and may be adjusted by a uniform discount. One-third off prices given here will bring most jobs to about the cost value:

8-cent paper.		100	250	500	1000	ADDED 100
8-lb. stock,	\$0.96 per thousand	\$1.25	\$1.85	\$2.25	\$3.05	\$0.17
10-lb. stock,	1.20 per thousand	1.25	1.90	2.35	3.30	.19
12-lb. stock,	1.44 per thousand	1.50	1.95	2.45	3.55	.21

10-cent paper.		100	250	500	1000	ADDED 100
8-lb. stock,	\$1.20 per thousand	1.50	1.90	2.35	3.30	.19
10-lb. stock,	1.50 per thousand	1.50	2.00	2.50	3.60	.22
12-lb. stock,	1.80 per thousand	1.50	2.05	2.65	3.90	.25

12-cent paper.		100	250	500	1000	ADDED 100
8-lb. stock,	\$1.44 per thousand	1.50	1.95	2.45	3.55	.22
10-lb. stock,	1.80 per thousand	1.50	2.05	2.65	3.90	.25
12-lb. stock,	2.16 per thousand	1.50	2.15	2.85	4.15	.29

14-cent paper.		100	250	500	1000	ADDED 100
8-lb. stock,	\$1.68 per thousand	1.50	2.00	2.60	3.80	.24
10-lb. stock,	2.10 per thousand	1.50	2.10	2.80	4.20	.28
12-lb. stock,	2.52 per thousand	1.50	2.25	3.00	4.60	.32

16-cent paper.		100	250	500	1000	ADDED 100
8-lb. stock,	\$1.92 per thousand	1.50	2.10	2.70	4.00	.26
10-lb. stock,	2.40 per thousand	1.50	2.20	2.95	4.50	.31
12-lb. stock,	2.88 per thousand	1.50	2.30	3.20	5.00	.36

18-cent paper.		100	250	500	1000	ADDED 100
8-lb. stock,	\$2.16 per thousand	1.50	2.15	2.85	4.25	.29
10-lb. stock,	2.70 per thousand	1.50	2.30	3.10	4.80	.34
12-lb. stock,	3.24 per thousand	1.50	2.40	3.35	5.35	.39

20-cent paper,		100	250	500	1000	ADDED 100
8-lb. stock,	\$2.40 per thousand	1.50	2.20	2.95	4.50	.31
10-lb. stock,	3.00 per thousand	1.50	2.35	3.25	5.10	.37
12-lb. stock,	3.60 per thousand	1.50	2.50	3.55	5.70	.43

Figure on 12c. paper and 10-lb. stock, unless otherwise requested.

NOTE AND MEMORANDUM HEADINGS.

This class of work is usually printed on 8s of folio, either the broad or narrow way. The different values of paper represent the cost to the printer. One-third off the prices given here will bring most jobs to about the cost value :

	100	250	500	1000	ADDED 100
8-cent paper.					
4-lb. stock, \$0.48 per thousand	\$1.25	\$1.75	\$2.00	\$2.60	\$0.12
5-lb. stock, .60 per thousand	1.25	1.75	2.05	2.70	.13
10-cent paper.					
4-lb. stock, \$0.60 per thousand	1.50	1.75	2.05	2.70	.13
5-lb. stock, .75 per thousand	1.50	1.80	2.15	2.85	.15
6-lb. stock, .90 per thousand	1.50	1.85	2.20	3.00	.16
7-lb. stock, 1.05 per thousand	1.50	1.90	2.30	3.15	.17
12-cent paper.					
4-lb. stock, \$0.72 per thousand	1.50	1.80	2.10	2.80	.14
5-lb. stock, .90 per thousand	1.50	1.85	2.20	3.00	.16
6-lb. stock, 1.08 per thousand	1.50	1.90	2.30	3.20	.18
7-lb. stock, 1.26 per thousand	1.50	1.90	2.40	3.35	.20
14-cent paper.					
4-lb. stock, \$0.84 per thousand	1.50	1.80	2.25	2.95	.15
5-lb. stock, 1.05 per thousand	1.50	1.90	2.30	3.15	.18
6-lb. stock, 1.26 per thousand	1.50	1.90	2.40	3.35	.20
7-lb. stock, 1.47 per thousand	1.50	2.00	2.50	3.55	.22
16-cent paper.					
4-lb. stock, \$0.96 per thousand	1.50	1.85	2.25	3.15	.17
5-lb. stock, 1.20 per thousand	1.50	1.90	2.35	3.30	.19
6-lb. stock, 1.44 per thousand	1.50	1.95	2.45	3.55	.22
7-lb. stock, 1.68 per thousand	1.50	2.05	2.60	3.80	.24
18-cent paper.					
4-lb. stock, \$1.08 per thousand	1.50	1.90	2.30	3.20	.18
5-lb. stock, 1.35 per thousand	1.50	1.95	2.45	3.45	.21
6-lb. stock, 1.62 per thousand	1.50	2.00	2.55	3.70	.23
7-lb. stock, 1.89 per thousand	1.50	2.10	2.70	4.00	.26
20-cent paper.					
4-lb. stock, \$1.20 per thousand	1.50	1.90	2.35	3.30	.19
5-lb. stock, 1.50 per thousand	1.50	1.95	2.50	3.60	.22
6-lb. stock, 1.80 per thousand	1.50	2.00	2.65	3.90	.25
7-lb. stock, 2.10 per thousand	1.50	2.15	2.80	4.20	.28

Figure on 12c. paper and 5-lb. stock, unless otherwise requested.

BEER OR MILK TICKETS.

On heavy, tough check, 100 for \$1.00; 500 for \$1.50; 1000 for \$2.00; change of price or quantity in same order, 20c. for each change.

RESTAURANT AND HOTEL BILLS OF FARE.

- Breakfast or supper, 8s of 24-lb. folio post, at 12c.
 500 copies, \$3.30; 1,000 copies, \$4.50. Added 1,000 copies, \$1.90.
 Dinner bills, same general style, printed on two sides.
 500 copies, \$4.95; 1,000 copies, \$6.00. Added 1,000 copies, \$2.50.
 Dinner bills, 4 pages, quarter-sheet folio with wine list.
 500 copies, \$7.50; 1,000 copies, \$9.15. Added 1,000 copies, \$3.60.
 Skeleton bills to be filled in daily.
 125 of thin card per 1,000, \$5.65. Added 1,000, \$3.30.
 Restaurant bills on 6s of flat cap.
 500 copies, \$3.00; 1,000 copies, \$4.00. Added 1,000 copies, \$1.80.

ENVELOPES.

In this list of prices there is one-third added to the general net cost price.

No. 6 Size.		100	250	500	1000	ADDED 100
60-lb. No. 1 rag,	\$1.60 per thousand	\$1.00	\$1.35	\$1.90	\$3.10	\$0.22
50-lb. No. 1 rag,	1.47 per thousand	1.00	1.35	1.85	2.95	.21
60-lb. No. 2 rag,	1.35 per thousand	1.00	1.30	1.80	2.85	.20
50-lb. No. 2 rag,	1.27 per thousand	1.00	1.25	1.75	2.75	.19
60-lb. No. 1 wood,	1.13 per thousand	1.00	1.25	1.65	2.65	.17
50-lb. No. 1 wood,	1.00 per thousand	1.00	1.20	1.60	2.50	.16
50-lb. manilla,	.87 per thousand	1.00	1.20	1.55	2.35	.15
36-lb. manilla, white,	1.00 per thousand	1.00	1.20	1.60	2.50	.16
36-lb. manilla,	.73 per thousand	1.00	1.15	1.45	2.25	.13

No. 6 1/2 Size.		100	250	500	1000	ADDED 100
60-lb. No. 1 rag,	1.80 per thousand	1.00	1.40	2.00	3.30	.24
50-lb. No. 1 rag,	1.53 per thousand	1.00	1.40	1.90	3.00	.21
60-lb. No. 2 rag,	1.53 per thousand	1.00	1.40	1.90	3.00	.21
50-lb. No. 2 rag,	1.33 per thousand	1.00	1.30	1.80	2.90	.20
60-lb. No. 1 wood,	1.27 per thousand	1.00	1.30	1.75	2.80	.19
50-lb. No. 1 wood,	1.07 per thousand	1.00	1.25	1.65	2.60	.17
50-lb. manilla,	1.00 per thousand	1.00	1.25	1.60	2.50	.16
36-lb. manilla, white,	1.07 per thousand	1.00	1.25	1.65	2.60	.17
36-lb. manilla,	.80 per thousand	1.00	1.20	1.50	2.30	.14

No. 10 Size.		100	250	500	1000	ADDED 100
60-lb. No. 1 rag,	2.87 per thousand	1.25	1.70	2.55	4.40	.37
50-lb. No. 1 rag,	2.47 per thousand	1.25	1.65	2.40	3.95	.33
60-lb. No. 2 rag,	2.53 per thousand	1.25	1.65	2.40	4.00	.33
50-lb. No. 2 rag,	2.20 per thousand	1.25	1.55	2.25	3.75	.30
50-lb. manilla,	1.53 per thousand	1.25	1.40	1.90	3.00	.23
36-lb. manilla,	1.27 per thousand	1.00	1.30	1.75	2.80	.21

No. 11 Size.		100	250	500	1000	ADDED 100
60-lb. No. 1 rag,	3.45 per thousand	1.30	1.85	2.85	5.00	.45
50-lb. No. 1 rag,	3.00 per thousand	1.30	1.70	2.65	4.45	.40

No. 12 Size.		100	250	500	1000	ADDED 100
60-lb. No. 1 rag,	4.05 per thousand	1.40	2.00	3.15	5.60	.50
50-lb. No. 1 rag,	3.40 per thousand	1.40	1.90	2.90	4.95	.44

FOR PRINTING ONLY—STOCK FURNISHED.

500	\$1.25	5,000	\$4.95	10,000	\$ 8.75
1,000	1.75	6,000	5.75	15,000	11.75
2,000	2.55	7,000	6.50	20,000	14.75
3,000	3.35	8,000	7.25	25,000	17.75
4,000	4.15	9,000	8.00		

Figure on 50-lb. No. 2 rag for ordinary business, unless otherwise requested. Colored envelopes on same grade.

DENNISON TAG ENVELOPE.

FOR SENDING BILLS WITH PACKAGE.

No. 17 P., 6 x 3 1/2, not printed, per thousand	\$3.25	No. 18 P., 7 1/2 x 3 3/8, not printed, per thousand	\$4.20
Printed, per thousand	4.50	Printed, per thousand	5.50

DENNISON CLASP ENVELOPE.

OPEN-END XXXX WEIGHT.

Size, 3 3/8 x 6 inches, per thousand	\$4.50	Size, 5 1/2 x 8 inches, per thousand	\$5.75
Size, 4 x 6 inches, per thousand	4.75	Size, 5 1/2 x 8 1/2 inches, per thousand	6.00
Size, 3 7/8 x 7 1/2 inches, per thousand	5.75	Size, 6 x 9 inches, per thousand	6.25
Size, 4 5/8 x 6 3/4 inches, per thousand	5.00	Size, 6 1/2 x 9 1/2 inches, per thousand	6.75
Size, 4 7/8 x 7 1/2 inches, per thousand	5.00	Size, 6 1/2 x 10 inches, per thousand	7.50
Size, 5 x 7 1/2 inches, per thousand	5.50	Size, 7 x 10 1/2 inches, per thousand	8.00

Printing, add \$1.50 per 1000.

POSTAL CARDS AND STAMPED ENVELOPES.

The customer should supply postal cards and stamped envelopes. When the stock is furnished by office the prices should be net.

Postal Cards, printed on one side.	STOCK FURNISHED	STOCK
	BY OFFICE.	FURNISHED
	NET FIGURES.	BY CUSTOMER.
100 cards	\$2.00	\$1.00
200 cards	3.20	1.10
300 cards	4.40	1.20
400 cards	5.50	1.35
500 cards	6.60	1.50
1,000 cards	12.50	2.00
Additional 1,000	11.50	1.00

Printing on two sides, add the last column of figures for the second run.

Stamped Envelopes, 2-cent postage, white, commercial size.

100 envelopes, \$21.80 per thousand	3.40	1.00
200 envelopes, 21.80 per thousand	5.80	1.10
300 envelopes, 21.80 per thousand	8.00	1.20
400 envelopes, 21.80 per thousand	10.40	1.35
500 envelopes, 21.80 per thousand	12.80	1.50
1,000 envelopes, 21.80 per thousand	24.45	2.00
Additional 1,000	23.80	1.00

One-cent postage, manilla, commercial size.

100 envelopes, \$11.08 per thousand	2.00	1.00
200 envelopes, 11.08 per thousand	3.40	1.10
300 envelopes, 11.08 per thousand	4.80	1.20
400 envelopes, 11.08 per thousand	6.20	1.35
500 envelopes, 11.08 per thousand	7.50	1.50
1,000 envelopes, 11.08 per thousand	14.00	2.00
Additional 1,000	12.60	1.00

One-cent postage, white, commercial size, add 8c. per 100 extra to manilla prices for stock furnished by office.

SHIPPING TAGS.

The following are list prices on Dennison tags, without printing:

SIZE.	N. Y. G.	DEN. E.	STAND- ARD P.	SIZE.	N. Y. G.	DEN. E.	STAND- ARD P.
1	\$0.25	\$0.40	\$0.90	5	\$0.50	\$0.85	\$1.60
230	.50	1.00	660	1.00	1.90
335	.60	1.20	770	1.15	2.30
440	.70	1.40	880	1.30	2.75

COLORED AND LINEN TAGS.

SIZE.	NOVELTY COL.	PAT. COL.	LINEN.	SIZE.	NOVELTY COL.	PAT. COL.	LINEN.
1	\$0.75	\$1.25	\$3.00	5	\$1.60	\$2.75	\$6.25
260	1.50	3.75	6	1.90	3.00	7.25
3	1.10	2.00	4.50	7	2.20	3.50	8.50
4	1.30	2.25	5.25	8	2.50	3.75	10.00

Add for printing to any one kind for 1000, \$1.50; for additional 1000s to 4000, 60c. per 1000; 5000 to 10,000, at 60c. per 1000; over 10,000, at 50c. per 1000. Discounts to be figured from the whole amount.

HOTEL REGISTERS.

Interleaved with blotting paper without advertisements.

	DEMY OR MEDIUM.
Books of 300 pages without blotters	\$9.50
Add for blotters	2.00
Total for one book	\$11.50
Added books in same order	7.80

PRINTED DRAFTS AND INDIVIDUAL CHECKS, BOUND.

Five forms to a half sheet of folio or royal, one book	500 FORMS. \$7.90	1000 FORMS. \$10.10
Additional books in same order	3.30	5.50

These are for numbered and perforated forms.

In books two or three deep, add 50c. for additional binding on each 1000 forms.

The names of drawers inserted where there is more than one order; charge, 50c. extra for each set of names. Names of drawers in red or other color, \$1.00 extra.

CUSTOMERS' CHECKS IN SMALL BOOKS.

Check Bound Books.—	20 BOOKS OF 50.	10 BOOKS OF 100.	2 BOOKS OF 500.
Total for 1,000 checks	\$ 5.70	\$ 5.30	\$ 4.90
Additional 1,000s	3.70	3.30	2.90
In lots of 5,000, setting two forms	15.60	14.10	13.00
In lots of 10,000, setting full form	27.00	25.00	25.00
In additional lots of 10,000	23.00	21.00	21.00

Twelve checks to one sheet of folio, reduce 15c. per 1000 checks, the paper (24-lb. folio) amounting to 75c.; all other charges the same.

BANK OR COUNTER CHECKS.

WITHOUT STUBS, LOOSE OR IN BLOCKS. SMALL, 2 3/4 x 7 1/4 INCHES, 18S FOLIO (STOCK, 40C.).

1,000 \$ 2.00	2,000 \$ 3.00	3,000 \$ 4.00
5,000 6.00	10,000 10.00	20,000 19.00
30,000 25.00	40,000 30.00	50,000 35.00

Large, 3 1/2 x 8 1/2 inches, 8s cap (stock, 50c.).

1,000 \$ 2.50	2,000 \$ 3.65	3,000 \$ 4.95
5,000 7.00	10,000 12.00	20,000 20.00
30,000 27.00	40,000 34.00	50,000 40.00

These prices are for loose checks, or simply glued in bulk at the top. If in blocks of 50, add 30c. per 1000 for the first 1000 and 20c. for subsequent 1000s.

Colored inks will add \$1.00 to the order.

DEBIT AND CREDIT SLIPS.

2 3/4 x 4 1/2, 32s folio (stock, 15c.).

1,000 \$ 1.25	2,000 \$ 1.70	3,000 \$ 2.00
5,000 3.00	10,000 5.00	20,000 9.00
30,000 13.00	40,000 17.00	50,000 21.00

3 5/8 x 4 1/2, 24s folio (stock, 20c.).

1,000 \$ 1.25	2,000 \$ 1.50	3,000 \$ 2.20
5,000 3.25	10,000 5.50	20,000 10.00
30,000 14.50	40,000 19.00	50,000 23.00

DEPOSIT TICKETS.

3 1/2 x 5 1/2, 20s of 20-lb. folio post at 8c. (paper 25c.).

1,000 \$ 1.50	2,000 \$ 2.00	3,000 \$ 2.50
5,000 3.50	10,000 6.00	20,000 11.00
30,000 16.00	40,000 21.00	50,000 25.00

4 1/2 x 7, 8s of 12-lb. cap at 8c. (paper 38c.).

1,000 \$ 1.50	2,000 \$ 2.30	3,000 \$ 3.15
5,000 4.25	10,000 7.50	20,000 14.00
30,000 20.00	40,000 26.00	50,000 31.00

CERTIFICATES OF DEPOSIT.

PRINTED TWO ON A LEAF OF FOLDED HALF ROYAL.

Printed two forms on a leaf, using bond paper	500 FORMS. \$7.35	1000 FORMS. \$10.00
Additional books in same order	3.60	7.00

NOTICES OF NOTES AND ACCEPTANCES.

3½ × 5½, 20s of 20-lb. folio post (paper 30c.).

1,000	\$ 1.50	2,000	\$ 2.40	3,000	\$ 3.30
5,000	4.20	10,000	8.00	20,000	15.00
30,000	21.00	40,000	26.00	50,000	30.00

BONDS AND COUPONS.

Township, school district, village and city bonds.	25	50	100
	COPIES.	COPIES.	COPIES.
Bond with 10 coupons	\$ 8.75	\$ 8.95	\$ 9.40
Additional 100 copies, \$2.40.			
Full sheet cap bond with 20 coupons	14.00	15.00	16.00
Additional 100 copies, \$3.30.			

RULED AND PRINTED BLANKS.

Double Cap (32-lb. paper, \$1.20 per hundred ; ruling, \$2.50).

One form on a sheet, one side	100	ADDED
	COPIES.	100.
Same, backed with one fold	\$7.10	\$1.50
Backed with same form	9.10	1.05
Two forms on a sheet, one side	7.35	1.00
Three forms on a sheet, one side	7.35	1.05
Four forms on a sheet, one side, setting two	7.55	1.05
	9.30	1.80

Side lines of figures, etc., adjusted to ruled lines, will add \$2.00 to first 100 copies.

Folio Post (24-lb. paper, 90c. per hundred ; ruling, \$2.50).

One form on a sheet	6.00	1.25
Same, backed with one fold	8.25	1.30
Backed with same form	6.30	1.60
Two forms on a sheet, one side	6.25	1.50
Three forms on a sheet	6.50	1.70
Four forms on a sheet	7.65	1.50

Side lines of figures, etc., adjusted to ruled lines, will add \$2.00 to first 100 copies.

Cap (16-lb. paper, 60c. per hundred ; ruling, \$2.00).

One form on a sheet	4.70	.80
Same, backed with one fold	6.35	.90
Backed with same form	4.90	1.05
Two forms on a sheet, one side, setting two	5.80	.90
Three forms on a sheet, setting three	7.00	1.00
Four forms on a sheet	6.10	1.15

Half-Sheet Folio (24-lb. paper, 45c. per hundred ; ruling, \$1.50).

One form on a sheet, one side	4.45	.75
Same, backed, with one fold	6.20	.90
Backed with same form	4.70	.90
Two forms on a sheet, one side, setting two	5.65	.75
Three forms on a sheet, one side, setting three	6.65	.75
Four forms on a sheet, one side, setting four	7.65	.75

Side lines of figures adjusted to ruled lines will add \$1.50 to first 100 copies.

Half-Sheet of Cap (16-lb. paper, 30c. per hundred ; ruling, \$1.00).

One form on a sheet	4.10	.55
Same, backed, with one fold	5.85	.65
Backed with same form	4.30	.65
Two forms on a sheet, one side, setting two	5.50	.60
Three forms on a sheet, setting three	6.50	.60
Four forms on a sheet, setting four	7.50	.60

Quarter-Sheet Folio (24-lb. paper, 23c. per hundred).

One form on a sheet	3.95	.50
Backed, with one fold	5.50	.40
Backed with same form	4.15	.60

Quarter-Sheet Cap (16-lb. paper, 15c. per hundred ; ruling, \$1.00).

One form on a sheet, one side	3.75	.40
Same, backed, with one fold	5.50	.40
Backed with same form	3.95	.50

Eighth Sheet of Folio (24-lb. paper, 12c. per hundred).

One form on a sheet, one side	3.45	.30
Backed, one fold	4.80	.35
Same form on both sides	3.60	.35

Blanks without ruling, omit prices for ruling as given above.

BANKERS' DEPOSIT BOOKS.

With printing on cover and on second and third pages inside.

	FIRST 100	ADDED 100
Press or tag-board covers, 3¾ × 5½ inches.		
6 leaves	\$3.50	\$2.00
12 leaves	4.50	3.00
24 leaves	5.50	4.00
Press or tag-board covers, 4¾ × 6¾ inches.		
12 leaves	5.00	3.40
24 leaves	6.00	4.50
Leather covers, 3¾ × 5½ inches.		
24 leaves	10.00	8.00
Leather covers, 4¾ × 6¾ inches.		
24 leaves	14.00	9.00
Leather covers, 3¾ × 7¾ inches.		
24 leaves	14.00	9.00

Interleaved books—the large sizes will be \$3.00 extra for each 100 books.

BLANK BOOKS.

In handling blank books, printers should abandon the quire figuring of 80 pages, and substitute 100 pages.

Half binding may be either tight or loose smooth back, with paper or cloth sides and leather corners, usually colored leather.

Three-quarter binding is first-class in every respect as to stock, usually russia back and corners, finished with raised cords or hubs and cloth sides.

Full end and band binding and extra russia ends and bands, full gilt back, are well-known to the trade and need not be described. The figures here submitted are for the best of their class as to binding.

FLAT CAP. 18-LB. WESTON OR BROWN.

Books of 400 pages—5 quires.	HALF BINDING.	THREE- QUARTER.	FULL E. & B.	EXTRA RUSSIA.
Ledgers, journals and blank books—paper, \$1.25; ruling, \$2.00	\$5.20	\$5.90	\$8.20	\$9.70
Added books in same order	3.50	4.20	6.50	8.00
Added 100 pages50	.50	.50	.50
Books with printed headings—ruling, \$2.50; composition, \$2.00; presswork, \$1.30	9.00	9.70	12.00	13.50
Added books in same order	3.90	4.60	6.90	8.40
Added 100 pages60	.60	.60	.60
Books with full-page printing; border ruling, \$1.50; composition, \$3.00; presswork, \$1.50	9.35	10.05	12.35	13.85
Added books in same order	3.80	4.50	6.80	8.30
Added 100 pages65	.65	.65	.65

If two pages are printed full, add \$1.50 to each book.

Omitting border on full-page printed books will take off \$1.50 from first book and 20c. from additional books.

For less number of pages, use the same figures as for additional 100 pages.

20-lb. best ledger will add 10c. for each 100 pages.

Index in front, add \$1.25 to each book, including paper. Index through, add \$2.00 to each book. Canvas cover, add \$1.00.

Printed numbered lines down one page, add \$1.00 to first book; and if on both pages, add \$2.00 for first book.

Patent back, \$1.25 extra.

All additions to be added to gross figures.

DEMY. 28-LB. WESTON OR BROWN.**Books of 400 pages—5 quires.**

	HALF BINDING.	THREE- QUARTER.	FULL E. & B.	EXTRA RUSSIA.
Ledgers, journals and blank books—paper, \$2.15; ruling, \$1.85	\$6.15	\$8.05	\$9.45	\$10.90
Added books in same order	4.40	6.30	7.70	9.15
Added 100 pages	.80	.80	.80	.80
Books with printed headings—ruling, \$2.50; composition, presswork, 1.30	10.10	12.00	13.40	14.85
Added books in same order	5.00	6.90	8.30	9.75
Added 100 pages	.90	.90	.90	.90
Books with full-page printing—border ruling, \$1.50; composition, 4.00; presswork, \$1.50	11.15	13.05	14.45	15.90
Added books in same order	5.00	6.90	8.30	9.75
Added 100 pages	.90	.90	.90	.90

If two pages are printed full, add \$1.50 to each book.

Omitting border on full-page printed books will take off \$1.50 from first book and 40c. from additional books.

For less number of pages, use the same figures as for additional 100 pages.

30-lb. best ledger will add 10c. for each 100 pages.

Index in front, add \$1.50 to each book, including paper. Index through, add \$2.00 to each book. Canvas cover, add \$1.25. Patent back, \$1.50 extra.

Printed numbered lines down one page, add \$1.50 to first book; and if on both pages, add \$2.50 for first book.

All additions to be added to gross figures.

MEDIUM. 36-LB. WESTON OR BROWN.**Books of 400 pages—5 quires.**

	HALF BINDING.	THREE- QUARTER.	FULL E. & B.	EXTRA RUSSIA.
Ledgers, journals and blank books—paper, \$3.00; ruling, \$2.75	\$8.25	\$10.35	\$11.85	\$12.45
Added books in same order	5.85	7.85	9.35	10.95
Added 100 pages	1.15	1.15	1.15	1.15
Books with printed headings—ruling, \$2.75; composition, \$3.00; presswork, \$1.75	12.90	15.00	16.50	18.10
Added books in same order	6.55	8.65	10.15	11.55
Added 100 pages	1.25	1.25	1.25	1.25
Books with full-page printing—border, \$1.75; composition, \$5.00; presswork, \$2.00	13.40	15.50	17.00	18.60
Added books in same order	6.55	8.65	10.15	11.55
Added 100 pages	1.25	1.25	1.25	1.25

If two pages are printed full, add \$2.00 to each book.

Omitting border on full-page printed books will take off \$1.75 from first book and 40c. from additional books.

For less number of pages, use the same figures as for additional 100 pages.

40-lb. best ledger will add 20c. for each 100 pages.

Index in front, add \$1.50 to each book, including paper. Index through, add \$2.00 to each book. Canvas cover, add \$1.50. Patent backs, \$2.00 extra.

Printed numbered lines down one page, add \$2.00 to first book; and if on both pages, add \$3.00 for first book.

All additions to be added to gross figures.

DOUBLE CAP. 36-LB. WESTON OR BROWN.**Books of 400 pages—5 quires.**

	HALF BINDING.	THREE- QUARTER.	FULL E. & B.	EXTRA RUSSIA.
Ledgers, journals and blank books—paper, \$2.50; ruling, \$2.75	\$8.00	\$10.20	\$11.70	\$13.45
Added books in same order	6.10	8.30	9.80	12.05
Added 100 pages	1.05	1.05	1.05	1.05
Books with printed headings—ruling, \$2.75; composition, \$4.00; presswork, \$1.75	13.65	14.85	17.35	19.60
Added books in same order	6.70	8.90	10.40	12.65
Added 100 pages	1.15	1.15	1.15	1.15
Books with full-page printing—ruling, \$2.00; composition, \$6.00; presswork, \$2.00	14.90	17.10	18.60	20.55
Added books in same order	6.90	9.10	10.60	12.85
Added 100 pages	1.20	1.20	1.20	1.20

If two pages are printed full, add \$2.00 to each book.

Omitting border on full-page printed books will take off \$2.00 from first book and 40c. from additional books.

For less number of pages, use the same figures as for additional 100 pages.

40-lb. best ledger will add 15c. for each 100 pages.

Index in front, add \$1.50 to each book, including paper. Index through, add \$2.00 to each book. Canvas cover, add \$2.00. Patent back, \$2.00 extra.

Printed numbered lines down one page, add \$2.00 to first book; and if on both pages, add \$3.00 for first book.

All additions to be added to gross figures.

ROYAL. 44-LB. WESTON OR BROWN.

Use double cap table, and add \$1.20 to each book of 400 pages, and 30c. for added 100 pages.

SUPER-ROYAL. 54-LB. WESTON OR BROWN.

Books of 400 pages—5 quires.

	HALF BINDING.	THREE- QUARTER.	FULL, E. & B.	EXTRA RUSSIA.
Ledgers, journals and blank books—paper, \$5.00; ruling, \$3.50	\$11.10	\$13.50	\$15.20	\$17.65
Added books in same order	8.60	11.00	12.70	15.15
Added 100 pages	1.70	1.70	1.70	1.70
Books with printed headings—ruling, \$3.50; composition, \$5.00; presswork, \$2.00	18.10	20.50	22.20	24.65
Added books in same order	9.40	11.80	13.50	15.95
Added 100 pages	1.90	1.90	1.90	1.90
Books with full-page printing—ruling, \$3.50; composition, \$9.00; presswork, \$3.00	23.10	25.50	27.20	29.65
Added books in same order	9.60	12.00	13.70	16.15
Added 100 pages	2.00	2.00	2.00	2.00

If two pages are printed full, add \$3.00 to each book.

Omitting border on full-page printed books will take off \$3.50 from first book and 50c. from additional books.

For less number of pages, use the same figures as for additional 100 pages.

Index in front, add \$2.00 to each book, including paper. Index through, add \$2.00 to each book. Canvas cover, add \$3.00. Patent back, \$2.50 extra.

Printed numbered lines down one page, add \$2.00 to first book; and if on both pages, add \$3.00 for first book.

All additions to be added to gross figures.

DOUBLE DEMY. 56-LB. WESTON OR BROWN.

Books of 400 pages—5 quires.

	HALF BINDING.	THREE- QUARTER.	FULL, E. & B.	EXTRA RUSSIA.
Ledgers, journals and blank books—paper, \$4.25; ruling, \$3.50	\$11.35	\$14.35	\$16.45	\$19.55
Added books in same order	8.50	11.50	13.60	16.70
Added 100 pages	1.55	1.55	1.55	1.55
Books with printed headings—ruling, \$3.50; composition, \$5.00; presswork, \$2.00	18.35	21.35	23.45	26.55
Added books in same order	9.10	12.10	14.20	17.30
Added 100 pages	1.70	1.70	1.70	1.70
Books with full-page printing—ruling, \$3.50; composition, \$9.00; presswork, \$3.00	25.35	29.35	31.45	34.55
Added books in same order	9.30	12.30	14.40	17.50
Added 100 pages	1.80	1.80	1.80	1.80

If two pages are printed full, add \$3.00 to each book.

Omitting border on full-page printed books will take off \$3.50 from first book and 50c. from additional books.

For less number of pages, use the same figures as for additional 100 pages.

Index in front, add \$2.00 to each book, including paper. Index through, add \$2.00 to each book. Canvas cover, add \$3.00. Patent back, \$2.50 extra.

Printed numbered lines down one page, add \$2.00 to first book; and if on both pages, add \$3.00 for first book.

All additions to be added to gross figures.

DOUBLE MEDIUM. 72-LB. WESTON OR BROWN.

Books of 400 pages—5 quires.	HALF BINDING.	THREE QUARTER.	FULL E. & B.	EXTRA RUSSIA.
Ledgers, journals and blank books—paper, \$6.00; ruling, \$4.00	\$13.90	\$17.50	\$20.00	\$23.75
Added books in same order	10.90	14.50	17.00	20.75
Added 100 pages	2.00	2.00	2.00	2.00
Books with printed headings—ruling, \$4.00; composition, \$6.00; presswork, \$2.00	21.90	25.50	28.00	31.75
Added books in same order	11.50	15.10	17.60	21.35
Added 100 pages	2.20	2.20	2.20	2.20
Books with full-page printing—ruling, \$3.50; composition, \$10.00; presswork, \$3.00	26.40	30.00	32.50	36.25
Added books in same order	11.70	15.30	17.80	21.55
Added 100 pages	2.30	2.30	2.30	2.30

If two pages are printed full, add \$3.00 to each book.

Omitting border on full-page printed books will take off \$3.50 from first book and 50c. from additional books.

For less number of pages, use the same figures as for additional 100 pages.

Index in front, add \$2.50 to each book, including paper. Index through, add \$2.00 to each book. Canvas cover, add \$3.50. Patent back, \$2.50 extra.

Printed numbered lines down one page, add \$2.00 to first book; and if on both pages, add \$3.00 for first book.

All additions to be added to gross figures.

BLANK BOOKS WITH STUBS OR DUPLICATES.

PRINTED, NUMBERED, PERFORATED AND BOUND.

Half-Bound, Double Cap (32-lb. \$1.20).	ONE BOOK 100 LEAVES.	ADDED 100 LEAVES IN SAME BOOK.
Two forms on a full sheet; composition, \$6.00, setting one.		
In duplicate, 200 forms	\$12.50	\$2.10
Additional books	4.90	2.10
Three forms on a full sheet; composition, \$4.00, setting one.		
In duplicate, 300 forms	10.85	2.45
Additional books	5.25	2.45
Four forms on a full sheet; composition, \$6.00, setting two.		
In duplicate, 400 forms	12.90	2.50
Additional books	5.30	2.50
Half-Bound, Folio Post (24-lb. 90c.).		
Two forms on a full sheet; composition, \$4.00, setting one.		
In duplicate, 200 forms	8.40	1.80
Additional books	3.30	1.80
Three forms on a full sheet; composition, \$3.00, setting one.		
In duplicate, 300 forms	7.75	2.15
Additional books	3.65	2.15
Four forms on a full sheet; composition, \$4.00, setting two.		
In duplicate, 400 forms	8.80	2.20
Additional books	3.70	2.20
Five forms on a full sheet.		
In duplicate, 500 forms	10.00	2.40
Additional books	3.90	2.40
Six forms on a full sheet.		
In duplicate, 600 forms	10.20	2.50
Additional books	4.10	2.50
Half-Bound, Flat Cap (16-lb., 60c.).		
Two forms on a full sheet; composition, \$3.00, setting one.		
In duplicate, 200 forms	7.40	1.50
Additional books	2.80	1.50
Three forms on a full sheet; composition, \$2.00, setting one.		
In duplicate, 300 forms	6.75	1.55
Additional books	3.15	1.55
Four forms on a full sheet; composition, \$3.00, setting two.		
In duplicate, 400 forms	7.80	1.90
Additional books	3.20	1.90
Five forms on a full sheet.		
In duplicate, 500 forms	9.00	2.10
Additional books	3.40	2.10

BLANK BOOKS WITH STUBS OR DUPLICATES.PRINTED, NUMBERED, PERFORATED AND BOUND—*Continued.*

	ONE BOOK 100 LEAVES.	ADDED 100 LEAVES IN SAME BOOK.
Half-Bound, Half-Folio Post (24-lb., 45c.).		
Two forms on a half sheet; composition, \$2.50, setting one.		
In duplicate, 200 forms	\$6.05	\$1.35
Additional books	2.45	1.35
Three forms on a half sheet; composition, \$2.00, setting one.		
In duplicate, 300 forms	5.90	1.70
Additional books	2.80	1.70
Four forms on a half sheet; composition, \$2.50, setting two.		
In duplicate, 400 forms	6.45	1.75
Additional books	2.85	1.75
Five forms on a half sheet; composition, \$3.50, setting three.		
In duplicate, 500 forms	7.90	2.20
Additional books	3.30	2.20
Six forms on a half sheet; composition, \$3.50, setting three.		
In duplicate, 600 forms	7.85	2.05
Additional books	3.15	2.05
Half-Bound, Half Cap (16-lb., 30c.).		
One form in duplicate	6.00	.80
Additional books	1.90	.80
Two forms on a half-sheet.		
In duplicate, 200 forms	6.70	1.00
Additional books	2.10	1.00
Three forms on a half sheet.		
In duplicate, 300 forms	6.90	1.20
Additional books	2.30	1.20
Four forms on a half sheet.		
In duplicate, 400 forms	7.10	1.30
Additional books	2.50	1.30
Five forms on a half sheet.		
In duplicate, 500 forms	7.30	1.40
Additional books	2.70	1.40
Half-Bound, Quarter-Sheet Folio (24-lb., 23c.).		
One form on a quarter sheet.		
In duplicate, 100 forms	5.90	.75
Additional books	1.80	.75
Two forms on a quarter sheet.		
In duplicate, 200 forms	6.60	.90
Additional books	2.00	.90
Three forms on a quarter sheet.		
In duplicate, 300 forms	6.80	1.15
Additional books	2.20	1.15
Half-Bound, Quarter-Sheet Cap (16-lb., 15c.).		
Long form on a quarter sheet.		
In duplicate, 100 forms	4.10	.60
Additional books	1.20	.60
Without perforating or numbering	3.65	.40
Additional books	1.00	.40
One form on a quarter sheet.		
In duplicate, 100 forms	4.60	.55
Additional books	1.50	.55
Two forms on a quarter sheet.		
In duplicate, 200 forms	4.80	.75
Additional books	1.65	.75

TriPLICATE forms, add for extra numbers and perforations on each book of 100 forms, 15 cents; 200 forms, 20 cents; 300 forms, 25 cents; 400 forms, 30 cents; 500 forms, 35 cents; 600 forms, 40 cents.

Check binding will reduce the figures on any one book \$1.00. Duck binding will reduce the figures on any one book 50c.

If not numbered, reduce 10c. for every 100 forms.

COMMISSIONS SALES ACCOUNTS.

On 4s of 16-lb. cap, at 12c. ; ruled to order.
100 copies, \$3.50 ; 1,000 copies, \$5.10. Added 1,000 copies, \$2.60.

On 4s of 24-lb. folio, at 12c. ; ruled to order.
100 copies, \$2.70 ; 500 copies, \$4.10 ; 1,000 copies, \$6.00. Added 1,000 copies, \$3.60.

GUARD BOOKS OR PLAT BOOKS.

Quarter medium, 150 leaves, manilla paper, half-bound, paper sides, \$2.50.

Half medium, 200 leaves, \$3.00.

Full medium size, 200 leaves, \$5.00.

Large sizes, \$6.00 to \$10.00.

NUMBERING AND PERFORATING.

Consecutive numbering on cards, checks, deposit certificates, etc. :

500 numbers \$0.40 | 1,000 numbers \$0.50

Over 1000 numbers, 50c. per 1000.

Perforating in small quantities :

100 perforations \$0.20 | 1,000 perforations \$0.50
500 perforations40 | Over 1,000, per thousand50

BINDING BLANK BOOKS WITHOUT THE RULING, PRINTING OR PAPER COUNTED IN.**400 pages—5 quires.**

	HALF BDG.	THREE QUARTERS.	FULL	EXTRA E. & B.
Flat cap	\$1.60	\$2.30	\$4.60	\$6.10
Added 100 pages10	.10	.10	.10
Demy	1.80	3.70	5.10	6.55
Added 100 pages15	.15	.15	.15
Medium	2.15	4.25	5.75	7.35
Added 100 pages20	.20	.20	.20
Royal and double cap	2.40	4.60	6.10	8.35
Added 100 pages25	.25	.25	.25
Super royal	2.60	5.00	6.70	9.15
Added 100 pages25	.25	.25	.25
Double demy	3.25	6.25	8.35	11.45
Added 100 pages25	.25	.25	.25
Double medium	3.90	7.50	10.00	13.75
Added 100 pages25	.25	.25	.25

RULING ON BLANKS.**Demy or smaller, under 20 down pens.**

	100	250	500	1000	ADDED 100
One run	\$0.90	\$1.00	\$1.10	\$1.40	\$0.05
Two runs	1.50	1.70	2.00	2.50	.08
Three runs	2.00	2.25	2.75	3.25	.12
Four runs	2.50	2.80	3.30	4.00	.15

Double cap or smaller, under 40 down pens.

	1.00	1.25	1.60	2.00	.00
One run	1.00	1.25	1.60	2.00	.00
Two runs	1.80	2.10	2.50	3.10	.12
Three runs	2.50	2.85	3.50	4.25	.15
Four runs	3.00	3.50	4.10	5.00	.18

Double demy or smaller, under 60 down pens.

	1.50	2.00	2.75	3.25	.08
One run	1.50	2.00	2.75	3.25	.08
Two runs	2.25	2.75	3.50	4.25	.16
Three runs	3.00	3.50	4.25	5.25	.20
Four runs	3.75	4.25	5.00	6.25	.25

Double medium or smaller, under 80 down pens.

	2.00	2.50	3.00	3.75	.10
One run	2.00	2.50	3.00	3.75	.10
Two runs	3.00	3.50	4.00	5.00	.20
Three runs	4.00	4.50	5.00	6.25	.25
Four runs	5.00	5.50	6.00	7.50	.30

JOB BINDING, WITHOUT NUMBERING AND PERFORATING.

Quarter cap or up to 4 x 12.

	CHECK.	DUCK.	HF. BDG.
Single books of 100 leaves or less	\$0.15	\$0.40	\$0.75
Additional books in same order10	.30	.65
Twenty books or over, per book10	.25	.60
Books of 50 leaves only, in orders over 20, per book08	.20	.50

Quarter folio or up to 5 1/2 x 17.

Single books of 100 leaves or less25	.50	.90
Additional books in same order20	.40	.80
Twenty books or over, per book15	.35	.75
Single books of 200 leaves, or over 100 leaves30	.60	1.00
Additional books in same order25	.50	.90
Twenty books or over, per book20	.40	.80

Half sheet cap or up to 5 1/3 x 22.

Single books of 100 leaves or less30	.60	1.10
Additional books in same order25	.50	.90
Twenty books or over, per book20	.40	.80
Single books of 200 leaves, or over 100 leaves35	.65	1.10
Additional books in same order30	.55	1.00
Twenty books or over, per book25	.40	.90

Half sheet folio, demy or medium, either way.

Single books of 100 leaves or less40	.70	1.10
Additional books in same order30	.60	1.00
Twenty books or over, per book25	.45	.75
Single books of 200 leaves, or over 100 leaves45	.75	1.15
Additional books in same order35	.65	1.05
Twenty books or over, per book30	.50	.80

Full sheet cap, not folded.

Single books of 100 leaves or less45	.75	1.15
Additional books in same order35	.65	1.05
Twenty books or over, per book30	.50	.80
Single books of 200 leaves, or over 100 leaves50	.80	1.20
Additional books in same order40	.70	1.10
Twenty books or over, per book35	.55	.85

Perforating, 50c. per 1000 perforations.

Numbering, 50c. per 1000 numbers.

PAMPHLET BINDING.

	WITHOUT COVER.		WITH COVER.	
	SADDLE STITCH.	SIDE STITCH.	SADDLE STITCH.	SIDE STITCH.
8 pages, 1 form, per thousand copies	\$1.30	\$1.60	\$2.00	\$3.80
12 pages, 1 form, per thousand copies	1.40	1.70	2.20	4.00
16 pages, 1 form, per thousand copies	1.50	1.80	2.20	4.00
16 pages, 2 forms, per thousand copies	1.75	2.00	2.50	4.30
24 pages, 2 forms, per thousand copies	2.00	2.30	2.75	4.50
24 pages, 3 forms, per thousand copies	2.25	2.60	3.00	4.80
32 pages, 1 form, per thousand copies	2.00	2.30	2.50	4.50
32 pages, 2 forms, per thousand copies	2.25	2.60	3.00	4.80
	WITH COVER. SIDE STITCH.		WITH COVER SIDE STITCH.	
32 pages, 3 forms, per thousand copies	\$5.00	56 pages, 4 forms, per thousand copies	\$5.75	
32 pages, 4 forms, per thousand copies	5.00	56 pages, 5 forms, per thousand copies	6.00	
40 pages, 2 forms, per thousand copies	4.75	56 pages, 6 forms, per thousand copies	6.25	
40 pages, 3 forms, per thousand copies	5.00	56 pages, 7 forms, per thousand copies	6.50	
40 pages, 4 forms, per thousand copies	5.25	64 pages, 2 forms, per thousand copies	5.50	
40 pages, 5 forms, per thousand copies	5.50	64 pages, 3 forms, per thousand copies	5.75	
40 pages, 2 forms, per thousand copies	5.00	64 pages, 4 forms, per thousand copies	6.00	
48 pages, 3 forms, per thousand copies	5.25	64 pages, 5 forms, per thousand copies	6.25	
48 pages, 4 forms, per thousand copies	5.50	64 pages, 6 forms, per thousand copies	6.50	
48 pages, 5 forms, per thousand copies	5.75	64 pages, 7 forms, per thousand copies	6.75	
48 pages, 6 forms, per thousand copies	6.00	64 pages, 8 forms, per thousand copies	7.00	
56 pages, 3 forms, per thousand copies	5.50	72 pages, 9 forms, per thousand copies	7.50	

Without cover, deduct \$1.50. Every added 8-page form, 50c.; every added 16-page form, 75c. In orders less than 1000 use the proportionate value, adding one-tenth. On quarto forms add 10 per cent.

For cloth backs, add \$3.00 and for quarto, \$5.00 per 1000 copies. For holes punched in for strings, \$1.50 per 1000.

BINDING YEARLY PUBLICATIONS.

The prices herewith are *net figures* for single books, or two of a kind. For three or more volumes of same finish, 5 per cent. reduction may be made. For ten or more volumes of same finish, a 10 per cent. reduction can be made.

STYLE OF BINDING.	5 x 8	6 x 9	8 x 11	11 x 16	
	UNDER 800 PP.	SIX MONTHS.	SIX MONTHS.	SIX MONTHS.	ONE YEAR.
	NOVELS, LIBRARY BOOKS.	SUCH AS CENTURY, HARPERS'	SUCH AS LEBLIE'S MONTHLY	SUCH AS HARPERS' WEEKLY, YOUTH'S COMPANION	
Full cloth, stiff board sides	\$0.65	\$0.75	\$1.00	\$1.25	\$1.50
Half sheep or roan, sprinkled edges, cloth or paper sides75	.90	1.25	2.00	2.50
Full sheep or roan, sprinkled edges85	1.00	1.50	2.00	2.50
Half sprinkled sheep, library style, cloth sides, sprinkled edges90	1.15	1.65	2.25	2.75
Full sprinkled sheep, sprinkled edges95	1.25	1.75	2.50	3.00
Full sprinkled sheep, marbled edges	1.05	1.35	1.90	2.75	3.25
Half imitation morocco, cloth or paper sides, sprinkled or marbled edges	1.10	1.25	1.75	3.00	3.50
Half genuine morocco, marbled edges	1.25	1.50	2.25	3.50	4.00
Gilt edge extra on any book50	.75	1.00	1.25	1.50

RE-BINDING FOR PUBLIC LIBRARIES, SCHOOLS, ETC.

STYLE OF BINDING.	24mo.	18mo.	12mo.	8vo.	4to.
Half black leather (roan), cloth sides, no leather corners, gilt lettering on back, cloth joint	\$0.40	\$0.40	\$0.50	\$0.60	\$1.25
Half sheep leather, cloth sides, no corners, ink lettering on back, cloth joint30	.30	.40	.50	1.10

BINDING SHEET MUSIC.

	PER VOL.
Half morocco, cloth or paper sides	\$2.25
Half library roan, cloth or paper sides	1.75
Full morocco, flexible	3.00
Full roan or buffing, flexible	2.00
Full cloth, flexible or stiff	1.50

BINDING NEWSPAPER FILES.

	PER VOL.
One-half canvas back and paper board sides	\$1.50
One-half roan, paper sides	2.00

APR 23 1956

.















