

7/25/36 2165
The Elsie Robinson - Pforzheimer
Typographical Collection



Given by the Carl and Lily
Pforzheimer Foundation, Inc.





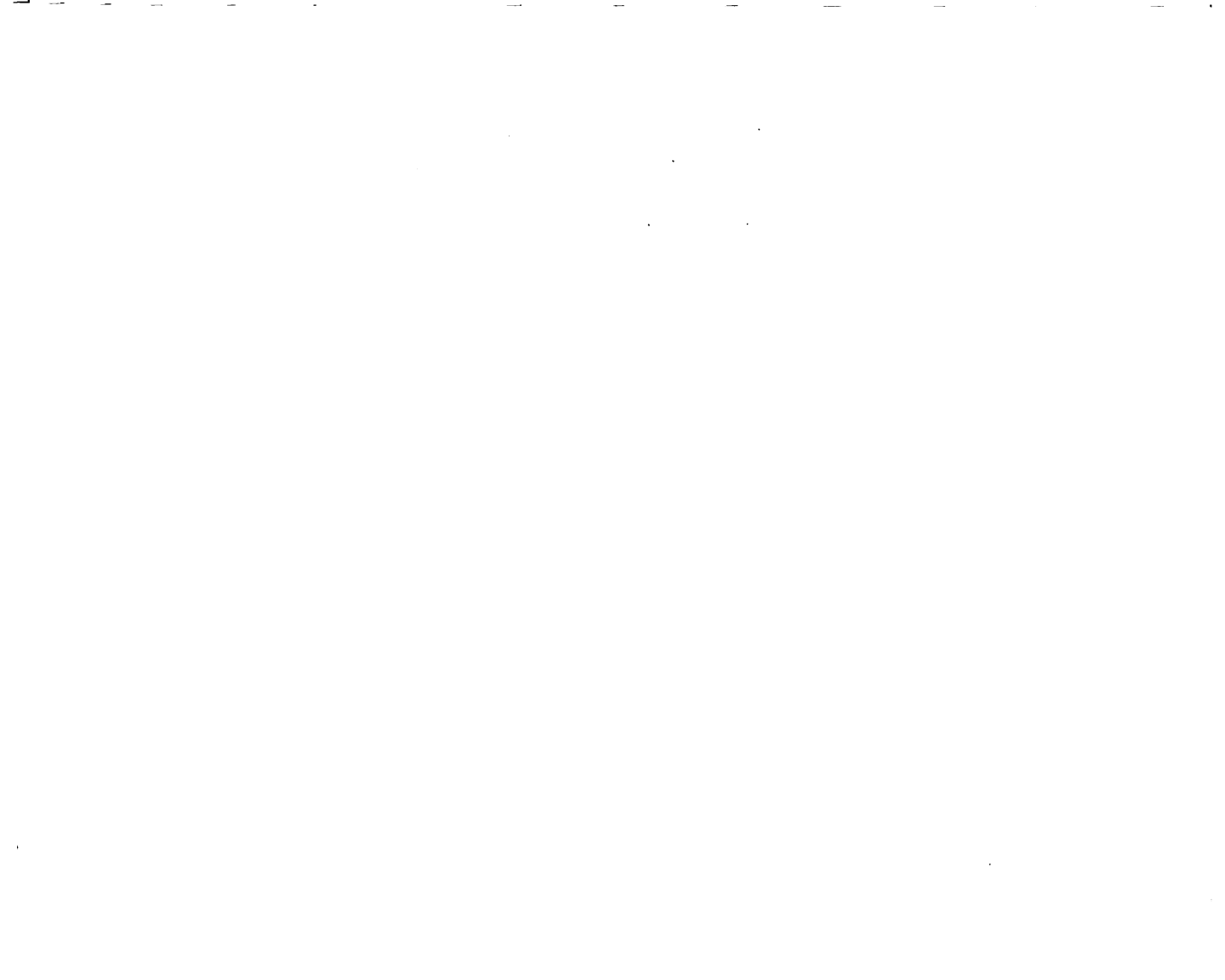



The Complete
Type Foundry



190-192 CONGRESS STREET, BOSTON, MASS.

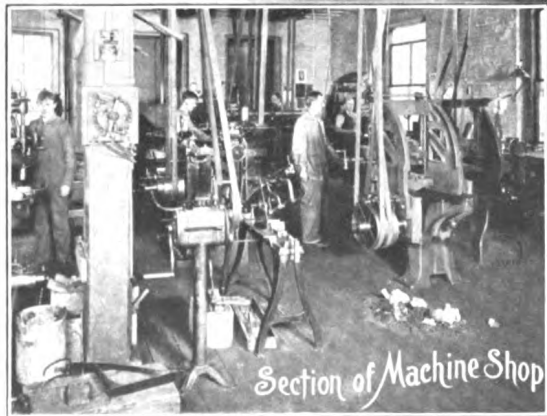
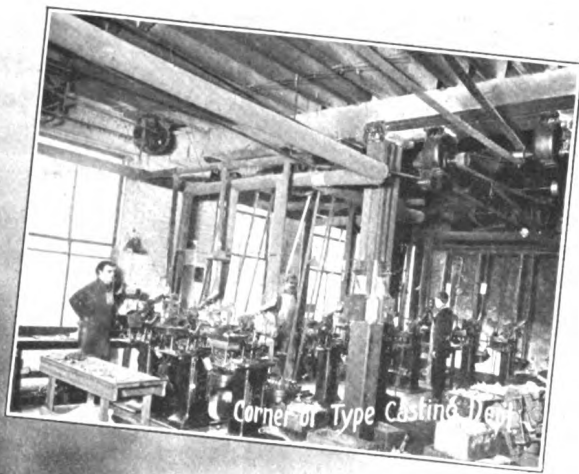

2185

Specimen Book of Type

and Printing Material



Manufactured by

H. C. HANSEN, Type Founder

190-192 Congress Street

BOSTON, MASS.

215

T TYPE. All Type, Borders, Ornaments, Leaders, etc. shown in this specimen book are cast by me from Superior Copper, Tin and Antimony Alloy Type Metal. Hundreds of faces being on the one line unit set. My facilities for manufacturing Book Type, Newspaper Type and Job Type have greatly increased at my new and commodious quarters, 190-192 Congress Street. The secret why Type and other articles made at my Establishment are so far superior to all others is largely due to the fact that I have the best trained artisans, the very best machinery, and all work done is overseen by me personally in all the departments. All Type sorts can be furnished at short notice, everything being cast under one roof.

NEW INVENTIONS. I have recently received several patents for latest improved machinery to assist the printer in keeping up-to-date and obtaining results that cannot be obtained by inferior machines.

BRASS RULES, Circles, Ovals, Braces and Dashes manufactured by me are known by the printers of New England and other parts of United States and Canada, to be superior to all others.

LEADS AND SLUGS of my manufacture from 15 to pica to 1 inch in thickness are too well known to require especial mention. Their high standard of the past will be maintained in the future.

METAL LEADERS, em dot, en dot and fine dot, shown on page 68 are especially designed for strength and to show a clear, light and even impression. The fine dot leaders will save justification where dotted lines are to be used with type.

METAL FURNITURE AND QUOTATIONS are finished to justify accurately with Point Standard Type. Take notice of the 15 new sizes of Quotations shown on page 8, cast on a type machine.

QUADS AND SPACES, without nicks, have proved to be of great advantage to Printers, and as I make them square on the ends, the different sizes can be more easily discerned.

GUARD LINES are shaved to 18-Point body, and planed to type-high: a great improvement over unfinished Guard Lines.

FIGURES are made to Point Standard in body and thickness shown on pages 171 to 178.

STANDARD TYPE MEASURES shown on page 245 are something new, but Printers will readily see their great advantage.

MACHINERY AND SUPPLIES. I carry one of the largest stocks of up-to-date machinery including Colt's Armory Platen Presses, Jones Gordon Presses and Cutters, and other supplies manufactured by leading concerns enabling me to supply the Printer satisfactorily and promptly.

I wish to express my sincere thanks to the thousands of customers who have so liberally patronized me in my endeavor to make this business a success, and hope to receive a continuance of the same, guaranteeing to fill their orders with the utmost precision and promptness.

H. C. HANSEN.

INDEX.

TYPE

ALL MANUFACTURED UNDER ONE ROOF

ACCENTS . . . 69-71, 167

Antique No. 31 . . . 126

Arrows and Arrow Pointers 170

BANDS . . . 183-194

Barrister Italic . . . 158

Bearers . . . 210

Black . . . 167

Bold Face No. 15 . . . 96

Bold Face No. 16 . . . 75

Borders and Ornaments . . 185

Borders . . . 73, 180 to 200

Boston Gothic . . . 114, 115

Braces and Half Braces . . 40

Braces, metal . . . 167

Brass Clamps, Curved Lines 41

Brass Circles . . . 25 to 28, 31

Brass Column Rules . . . 7

Brass Corners, round . . . 36, 38

Brass Corners, square, . . . 34

Brass Corner Quads . . . 41

Brass Dash Corners. . . . 38

Brass Dashes 36-38

Brass Flourishes 39

Brass Leads and Slugs . . . 7

Brass Leaders 41

Brass Ovals 29 to 33

Brass Pointers 168

Brass Rules 11 to 21

Brass Rule Borders . . . 42, 43

Brass Rules, L.S. . . . 22, 23

Brass Rules, mitered . . . 24

Brass Space Rule 7

Buffalo 76, 77, 78

Buffalo Italic 79

Buffalo Outline 80

Buffalo Accents 167

Buffalo Ornaments 200

CALENDAR FIGURES 171-178

Card Text Series . . . 159

Card Roman . . . 160, 161

Card Gothic . . . 162, 163

Card Gothic No. 2, . . . 165

Card Gothic No. 3 . . . 166

Card Pips, . . . 72

Caslon Old Style . . . 54-55

Caslon Job Fonts . . . 56

Caslon Old Style Italic . . . 57

Clarendon 128

Congress . . . 130, 131

Commonwealth . . . 132, 133

Cursive Script . . . 167

DE VINNE . . . 84, 86

De Vinne Fractions . . . 72

De Vinne Condensed . . . 86, 87

De Vinne Italic . . . 88

ECLAT 122

Eclat Outline 123

Extended Lining Gothic. . . 107

FANCY DASHES . . . 73

Figures 171 to 178

Fists 73

Flag Bands 194

Fractions 72

French Old Style . . . 44, 45

French Old Style Job Fonts 92-93

GOTHIC No. 1 . . . 100

Gothic Cond. No. 2 . . . 101

Gothic Cond. No. 3 . . . 102, 103

Gothic Cond. No. 4 . . . 104, 105

Gothic Cond. No. 5 . . . 106

Gothic No. 6 . . . 108, 109

Gothic, Medium No. 7 110, 111

Gothic No. 8 . . . 116, 117

Gothic Italic . . . 120

HANSEN OLD STYLE 90, 91

Hansen Old Style No. 2 . . 129

Hansen Old Style Initials . 74

Hansen Ornaments . . . 199

Holly Border . . . 200

Howland . . . 81

INCLINED GOTHIC . . . 121

Italic Job Fonts . . . 64, 65

JOB Fonts, mod. and O.S. 53, 63

LATIN ANTIQUE . . . 124

Latin Condensed . . . 125

Laurel Border . . . 188, 189

Leaders, Brass, L. S. . . 41

Leaders, Metal . . . 7, 68

Lining Gothic . . . 118, 119

Lions 72

Logotypes, 72

MAILING TYPE 62

Marguerite Border . . . 187

Medium Gothic No. 7 110 to 112

Metal Rule 194

Metal Furniture 8, 9

Metal Furniture, L.S. . . 10

Metal Quotations . . . 8, 9

Miscellaneous Signs . . . 72

Modern Antique . . . 127

ORNAMENTS . . . 184 to 200

Old Style and Italic No. 10, 46-48

Old Style and Italic No. 11, 49

Old Style and Italic No. 12 50-52

PARENTHESIS . . . 73

Plate Roman . . . 164

Pointers . . . 168 to 170

Poster Buffalo . . . 134 to 137

Poster Buffalo Outline 138 to 140

Poster De Vinne . . . 141 to 143

Poster De Vinne Cond. 144 to 146

Poster Stratford O. S. 147 to 149

Poster Antique No. 31, 150, 151

Poster Latin Antique, 152, 153

Poster Hansen Old Style 154, 155

Poster Hansen O.S. No. 2156, 157

Private Mailing Card . . . 179

RECIPE SIGNS . . . 72

Roman and Italic . . . 58 to 61

Roman Job Fonts . . . 53, 63

Roman and O. S. Italic 64, 65

Roman 58 to 62

Ronaldson O.S. No 12 50 to 53

SCRIPT LOGOTYPES . . . 72

Signs, Ballot 194

Stands, Double 226

Stands, Single 226

Stands, Quadruple . . . 227

Stands, Polhemus . . . 227

Stands, City 228

Stars 73

Stenograf 94

Stratford Old Style . . . 89

Studio Ornaments . . . 184, 186

Spaces and Quads 5

TRADE SIGNS 23

Tudor Black 82, 83

TypeWriter 94

VERTICAL SCRIPT . . . 99

Victoria Italic 113

Viking Italic 98

Viking, Job 96, 97

Viking 66, 67

Word Ornaments . . . 199

Wood Type

BUFFALO 202, 203

GOTHIC Condensed, . . . 201

Machinery and Materials.

AGATE MEASURES . . . 233

Annex Type Box . . . 230

BELLOWS 223, 237

Benzine and Lye Brushes 233

Benzine Cans 207

INDEX.

Machinery, etc. continued

BODKINS 204
Brackets; Case and Galley 205
Brackets, Tilting 206
Brass Label Holders 233
Bronzes 248
Bronzing Pad 237
CABINETS, Electro 229
Cabinets, Wisconsin Window 222
Cabinets, Galley 233
Cabinets, Porter steel run 223
Cabinets, Wood Type 224
Cabinets, Letter board 225
Cabinets Ink & Roller 229
Cabinets, Polhemus 225
Card Cutters 236
Cases 216, 221
Case Stands 226, 228
Case Racks 226
Caslon Self-locking galley 207
Cement 248
Chases, Wrought Iron 234
Colts Army Press 239
Column Rules 7
Composing & Make-up Rules 205
Composing Sticks 208, 209
Composing Stick Rack 208
Copy Holders 233
Copy Hooks 233
Cornering Machines 244
Counting Machine 228
Curving Machines 214
Cylinder Press Tape 233
DETERGENT, Grover's 248
Drying Racks 232

ELECTRIC Dissipator 248
Electric Motors 235
Estimates 6
Extension Feed Guides 211
Eye Shades 205
FILES 233
Form Truck 207
Furniture, L.S. Wood 230, 231
GALLEYS 206, 207
Galley Cabinets 233
Galley Proof Press 242
Galley Racks 205
Gauges 211, 214
Gauge Pins 211
Gauge Pin Drawer 211
Grover's Detergent 248
Guard Lines 7
HAND PUNCHES 233
Hand Rollers 207
Hansen's Gauges 211
Hansen's Mitering Machine 213
Hansen's Type Measure 214
Hansen's Curving Machine 214
Hansen's Pin Hole Perforator 246
Harris Rule Cases 219, 220
Horton Mailer 247
IMPOSING STONES 229
Imposing Stands 229
Ink Knives 205
Ink and Roller Cabinet 229
Inks 248
Ink Reducer 248
Iron Side and Foot Sticks 7
LABEL HOLDERS 233

Leader Boxes 225, 230
Lead Cutters 215, 247
Lead Racks 230, 231
Leads and Slugs 7
Leads and Slugs, L.S. 7
MAILING GALLEYS 206
Mailing Machine, Horton 247
Mailing Machine Gum 248
Mallets 204
Miter Box and Saw 204
Mitering Machine 213
Morton Lock-up 210
NUMBERING Machines 235
OIL CANS 233
PAD CEMENT 248
Paper Cutters 235
Paper Cutters, Ideal 241
Paste, Sphinx 248
Perforating Machines 246
Perforating Rules 7
Planers 204
Pliers 7
Poster Sticks, Wood 209
Presses, Colts Army 239
Presses, Jones Gordon 240
Presses, Lightning Jobber 241
Presses, Prouty 243
Presses, Chandler & Price 241
Press Counters 228
Press Punch 237
Press Points 205
Publications 233
QUOINS, Hempel 210

Quoins, Midget 210
Quoins, Wood 224
Quoins, Wickersham 210
RATGHETS for Pat. Blocks 212
Reducing Compound 248
Reglets, L.S. 231
Reglets in Strips 231
Reglet Case L.S. 231
Round Cornering Machine 244
Rule Borders 42, 43
Rule Cases, 218 to 220
SCREW DRIVERS 205
Shooting Sticks 204
Side Sticks, Beveled 7
Sigmund Ullman Inks 248
Soft'ng Ham'rs & Punches 242
Sort Boxes 230
Stands 226, 228
Steel Bearers 210
Stereotype Blocks 212
TAKE SLUGS 233
Tweezers 204
Thin Spaces, Assorted case 215
Type Measures 214, 233, 245
Type High Gauge 214
VARNISH 248
WIRE STITCHERS 238, 244
Wood Furniture L.S. 230, 231
Wood Furniture in strips 7
Wooden Gallies 230
Wood Poster Sticks 209
Wood Quoins 224
Wrenches 204

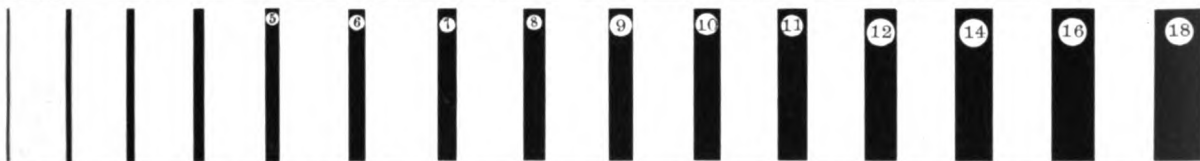

PRICE SCHEDULE

BODY TYPE PER LB. IN FONTS OF 25 LBS. OR OVER

SIZE	1ST CLASS SPCS. QUDS. ROM. TYPE	SECOND CLASS JOB TYPE	3D CLASS SCRIPTS & SPECIAL
5 POINT	\$1.20	\$1.80	\$2.80
5½ "	.74	1.44	2.40
6 "	.64	1.16	2.00
7 "	.56	1.00	1.80
8 "	.52	.90	1.60
9 "	.48	.80	1.44
10 "	.46	.74	1.30
11 "	.44	.70	1.22
12 "	.42	.66	1.16
14 "	.40	.62	1.12
16 "	.40	.60	1.00
18 "	.40	.60	1.00
20 "	.40	.60	.94
22 "	.40	.56	.90
24 "	.40	.56	.90
28 "	.40	.56	.86
30 "	.40	.56	.86
32 "	.40	.56	.86
36 "	.40	.56	.82
40 "	.40	.54	.78
42 "	.40	.54	.78
44 "	.40	.54	.78
48, 54, 60, 72	.40	.54	.72

All my Point Standard spaces and quads are NICKLESS and also perfectly square, justifying with any point Standard Type.

All spaces and en quads are sold at the first-class rate per pound.

On the em, 2 and 3 em quads there are reduced prices in quantities of 6 lbs. and over of one body ordered at one time Roman body type in lots of 500 lbs. and over sold at reduced rates.

Job Type in 100 lbs. and over sold at reduced rates.

If you wish for a special space, quad or anything to go in the chase not shown or mentioned in this catalogue be sure you write for it as I make hundreds of specialties not shown in the catalogue.

OLD METAL

Old Type, Leads, Slugs, Plates, Copper, Stereotypes, and Brass taken in exchange at current rates. F.O.B. Foundry

The best product guaranteed to be furnished at the lowest prevailing prices.

We also make and carry a stock of the following extra sizes of quads.

- 6-Pt. 4, 6 and 8 em quads.
- 8-Pt. 4 and 6 em quads
- 10-Pt. 4 em quads.
- 12-Pt. 4 em quads.

Sold at regular prices.

Special spaces and quads cast of any thickness at regular prices.

SORTS.

When ordering sorts to match, send cap H and lower case m.

COPPER THIN SPACES.

These spaces are made 1-Pt. and ½ Point thicknesses, on 12, 18, 24, 36, 48, 60 and 72-Point bodies.

Put up in boxes assorted sizes, 12 to 48-Point, \$1.00

6-Pt. to 72-Pt. in 2 oz. boxes, 25c. a box. Case of Thin Spaces shown on page 215. \$5.00

OLD STANDARD QUADS.

Spaces and quads on the old system (Boston and Dickinson) kept in stock. When ordering old system spaces and quads send sample.

Spaces and quads also made 54, 60, and 72-Point.

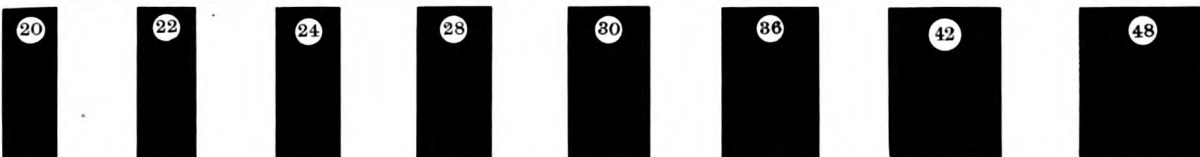

ESTIMATES.

FOR A MEDIUM SIZE JOB OFFICE.

1 12x18 Jones Gordon, patent Duplex fountain and steam fixtures	\$275.00
1 30-inch Ideal Paper Cutter	150.00
1 3x5 Imposing Stone and Frame	32.00
1 Double Polhemus Cabinet	75.00
2 Double stands for 24 cases each	13.50
4 Pair News Cases	6.40
40 Job and Triple Cases	36.00
3 Wood Type Cases	3.00
4 Harris rule cases in blank case	4.25
1 Metal Furniture case	1.50
1 10x16 Brass Galley	3.00
2 Double Brass Gallies	5.00
1 2 Tier Lead Rack	6.50
1 36-inch Wooden Stick	1.50
2 6-inch Sticks	1.50
1 10-inch Rouse Stick	2.35
1 16-inch Stick	1.45
1 Font L.S. Furniture and Case	8.00
Mallet, Planer, Proof Planer and Tweezer	1.50
Gauge Pins, Benzine Can and Brush	1.85
12 Pound L.S. 2-pt. hair line rule No. 109	18.60
50 " " " dotted rule No. 113	18.60
50 " " " Leads	9.50
50 " " " 6 and 12-pt. Slugs	9.50
20 Pound full length Leads	3.20
50 " L.S. Metal Furniture	12.50
1 Little Giant Lead and Rule Cutter	7.00
1 Miter Box, Saw, Pair Bellows, 10 lb. black Job Ink	8.00
Assorted Ink in Tubes	10.00
5 Fonts Wood Type, 2 doz. Quoins and Key, about	55.00
100 yards 6 and 12-pt. Reglet	2.00
100 pounds 10-pt. Body Type	46.00
50 pounds 8-pt. " "	23.00
25 pounds 6-pt. " "	16.00
25 pounds each 8 and 10-pt. Poster Type	41.00
5 pounds Brass Leaders and 3 fonts Borders, about	12.00
70 Fonts Gothics and Display Types, about	200.00
Spaces and Quads, about	20.00

1,141.20

All the above prices are subject to discounts, given on application. Everything carried in stock.

Ornament No. 25



48-Pt. 30 cts.

FOR A SMALL JOB OFFICE.

1 8x12 Jones Gordon, throw-off and steam fixtures,	\$145.00
1 18-inch Bench Cutter	60.00
1 Imposing Stone and Frame, 2x3 ft.	15.00
1 Mallet and Planer and Tweezer	1.00
1 Doz. Quoins and Key	1.75
1-2 Font Labor-saving Wood Furniture	5.00
25 Pound 6 and 12-point L.S. slugs	5.00
10 Pound 2-pt. full length Leads	1.60
1 Little Giant Lead and Rule Cutter	7.00
1 Eureka Lead and Slug Rack	2.50
1 Double Stand for 24 cases	6.75
2 Pair News Cases	3.20
22 California Job and Triple Cases	19.80
1 Harris L.S. Rule Case	.90
1 Pair Bellows Benzine Can and Brush	1.95
1 Cabinet with 20 two-third cases	21.00
1 Blank case	.65
1 Wood Type case	1.00
1 10x16 Brass Job Galley	3.00
1 6 1-4 x 23 3-4 Brass Job Galley	2.50
1 6-inch stick	.75
1 10-inch Rouse stick	2.35
3 Pound L.S. 2-pt. hair line rule	5.25
3 " " " dotted rule	5.25
1 Series Buffalo Job Type	38.15
1 Series Stratford Old Style	40.25
1 Series Card Roman	13.70
Various Gothic and Job faces, about	50.00
25 lbs. 10-pt. Body Type	11.50
5 Pound 10-pt. Leaders,	2.30
2 Fonts Wood Type, about	16.00
50 Yards 6 and 12-pt. Reglet	1.00
Borders and Ornaments, about	5.00
25 Pound Poster Type, about	15.00
Assorted Spaces and Quads	10.00
10 ft. 2-pt. hair line rule	1.00
10 " " dotted rule	1.00

\$523.10

All the above prices are subject to discounts, given on application. Everything carried in stock.

Ornament No. 26



48-Pt. 30 cts.

PRICE LIST.

METAL LEADERS

Shown on page 68

	Per lb.
6-Point	\$.64
7 "56
8 "52
9 "48
10 "46
11 "44
12 "42

BRASS LEADS AND SLUGS

	In strips	Cut Measure	Col. L. S.	Cut L. S.
1-Point, Per lb.	\$.80	\$.90	\$.150	
1½ " " "	.70	.80	1.35	
2 " " "	.65	.75	1.25	
6 " and thicker, .60	.70		1.10	

BRASS COLUMN RULES

Face Length	6-Pt.	7-Pt.	8-Pt.	9-Pt.	10-Pt.
13¼	\$.40	\$.45	\$.50	\$.55	\$.60
17¼	.50	.55	.65	.70	.80
19¼	.55	.60	.70	.80	.85
21¼	.60	.70	.75	.85	.95
23¼	.65	.75	.85	.95	1.05
25¼	.70	.80	.90	1.00	1.10

Each
add 1 in. .02¼ .03¼ .03¼ .04 .04¼

All pieces under 6 inches charged at price of 6 inches.

QUOINS

Hickory	100 per box 40 cts.
Boxwood	100 " 70 cts.

GUARD LINES

	Per lb.
Full Length	\$.20
Cut25

LEADS AND SLUGS

	Full Length	Cut 7 ems and over	Cut 2 to 6¼ ems pica
1-Ft.	\$.40	\$.48	\$.68
Ten to Pica30	.37	.54
1½-Ft. (8 to Pica) .24	.30	.44	
Seven to Pica20	.25	.40
2-Ft. (6 to Pica) and thicker .16	.20	.35	

LABOR-SAVING LEADS AND SLUGS

2-Point Leads, 6 and 12-Pt. Slugs	
25 lb. Font	\$.50
50 "	9.50
100 "	18.00

High Leads of all sizes same price as Low Leads

Special Lead made to order

BRASS SPACE RULE

	Per lb.
1-Point	\$.350
1 1-5 "	3.00
1½ "	2.50
2 "	2.00

PRINTERS' PLIERS

Round Nose, each,	\$.30
Flat Nose, "35

WOOD FURNITURE AND REGLET

6-Point, per Yd.	Pine	Cherry
8 " "	\$.01¼	\$.02
10 " "01¼	.02
12 " "01¼	.02
18 " "02	.03
24 " " (2-line)02¼	.03
36 " " (3-line)04	.04
48 " " (4-line)04	.04
60 " " (5-line)04	.04
72 " " (6-line)06	.06
96 " " (8-line)06	.06
120 " " (10-line)08	.08
144 " " (12-line)08	.08
216 " " (18-line)12	.12

Beveled Side Sticks06
Labor-Saving Cherry Furniture Font, 560 pieces and Rack,	\$.8.00
Labor-Saving Reglet Case, con- taining 2100 pieces, (275 yds.) 50 pcs. each, 10 to 50 ems,	\$.11.00

PERFORATING RULES

	Per Foot.
Steel Perforating Rule	\$.150
Brass " "15
Steel Cutting Rule20

IRON SIDE AND FOOT STICKS

Per inch	\$.04
--------------------	-------

NEW METAL QUOTATIONS

Cast on a Type Machine — Point System

15 SIZES

2 x 15, 3 x 15, 4 x 15,

2 x 13, 3 x 13, 4 x 13,

2 x 12, 3 x 12, 4 x 12,

2 x 10, 3 x 10, 4 x 10,

2 x 8, 3 x 8, 4 x 8,

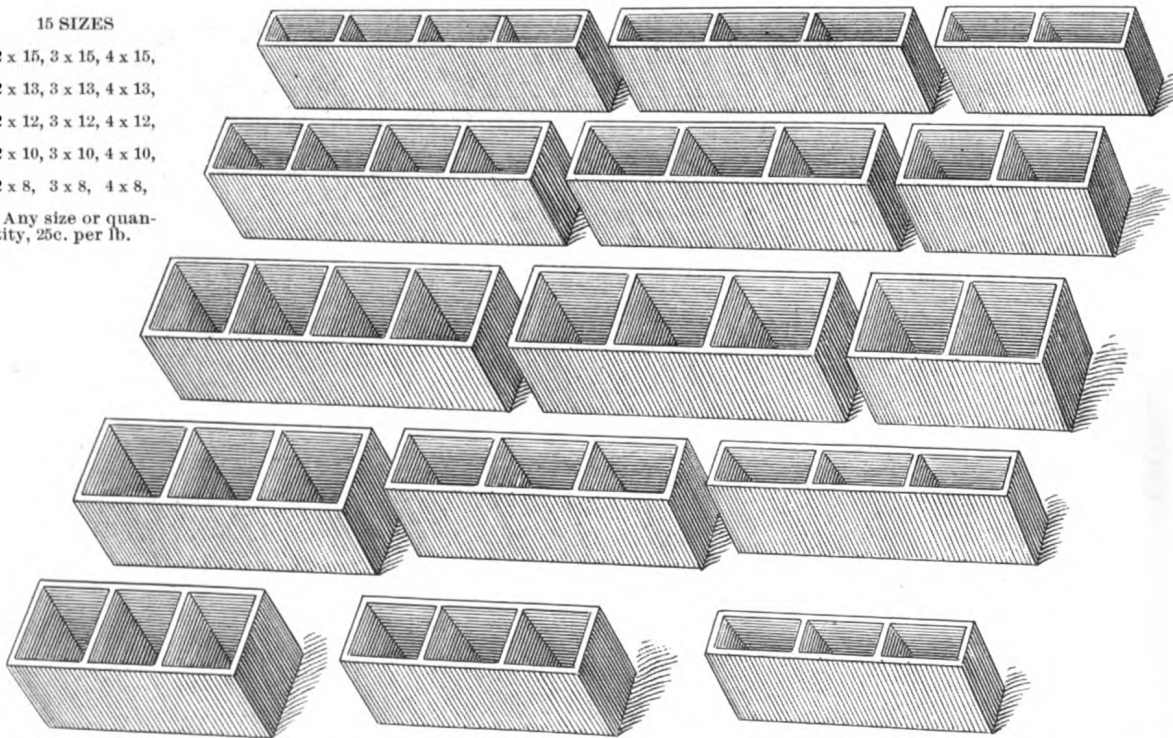
Any size or quantity,
25c. per lb.

Take notice to the 13 em lengths which enables the printer to obtain any odd lengths when used in combination with other sizes, in addition to its advantages of single column measure.

Put up in 25, 50 and 100 pound fonts, including the eleven sizes shown on opposite page.

METAL QUOTATIONS

POINT SYSTEM

2X3, 2X4, 2X5, 2X6,
3X3, 3X4, 3X5, 3X6,
4X4, 4X5, 4X6.

CAST IN STEEL MOULDS ON A
TYPE MACHINE

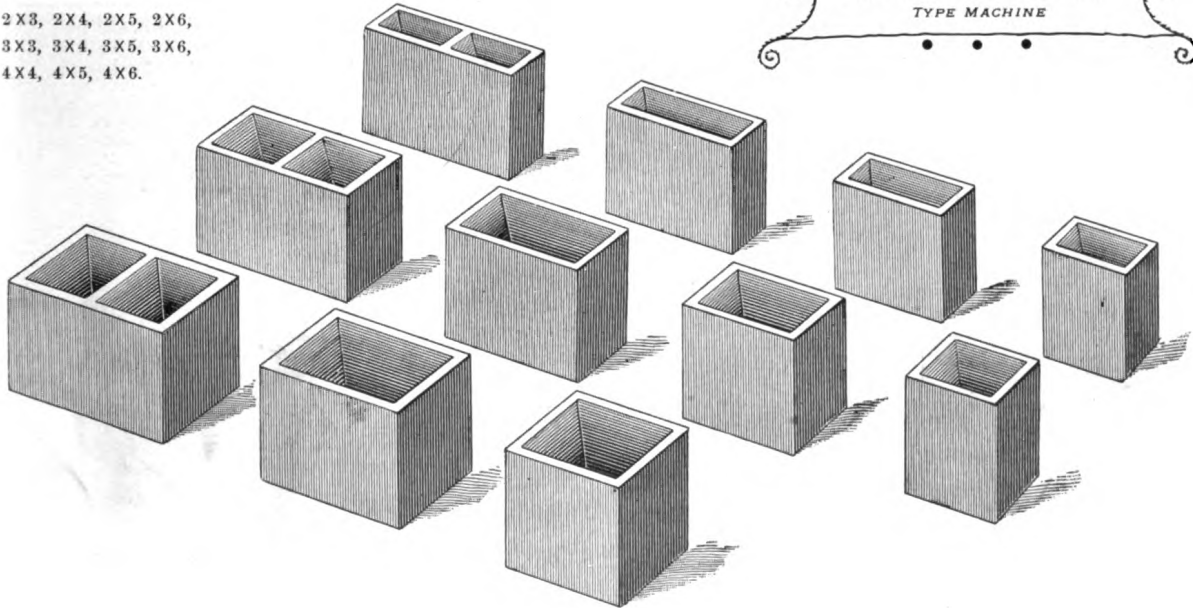

PRICE: 25c PER POUND. ANY SIZE OR QUANTITY.

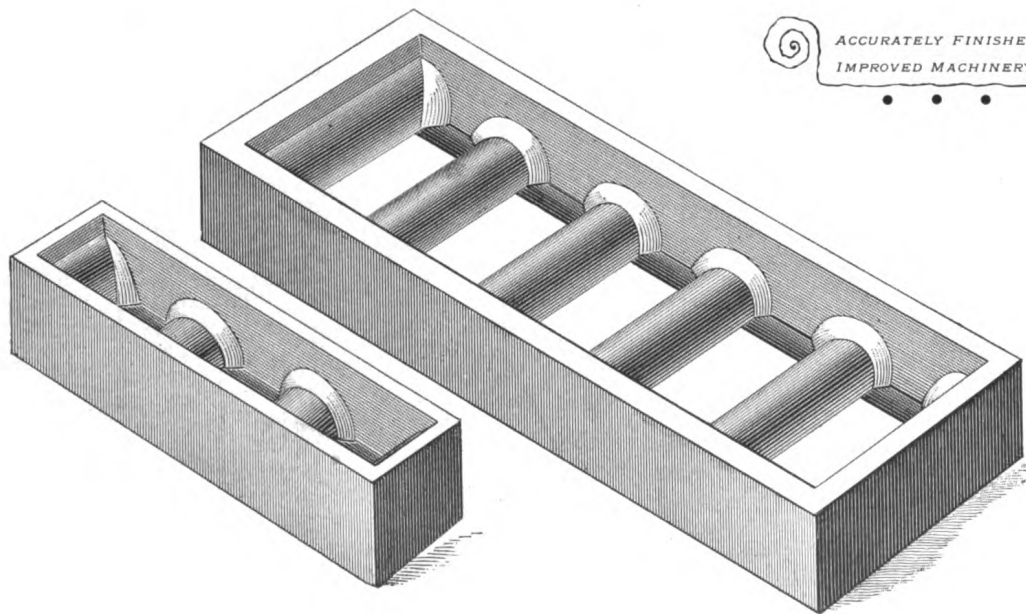
*LABOR-SAVING METAL FURNITURE**POINT SYSTEM*

ACCURATELY FINISHED BY
IMPROVED MACHINERY . . .



Put up in Fonts of 10, 20, 25 and 50 pounds. 2, 3, 4, 5, 6, 8, and 10 ems in width, and 4, 5, 6, 8, 10, 15, 20 and 25 ems in length. Other lengths to order.

PRICE: 25c. PER POUND

BRASS RULES.

No.		PER FOOT.
429	15 TO PICA.	5 cts.
430	15 TO PICA.	10 cts.
431	15 TO PICA.	5 cts.
432	1-PT.	5 cts.
433	1-PT.	10 cts.
428	1-PT.	5 cts.
434	1-PT.	5 cts.
101	10 TO PICA.	6 cts.
435	10 TO PICA.	10 cts.
102	10 TO PICA.	6 cts.
103	8 TO PICA.	7½ cts.
105	8 TO PICA.	7½ cts.
104	8 TO PICA.	7½ cts.
260	8 TO PICA.	12 cts.
283	8 TO PICA.	12 cts.
313	8 TO PICA.	12 cts.

No.		PER FOOT.
382	8 TO PICA.	12 cts.
109	2-PT.	10 cts.
343	2-PT.	10 cts.
436	2-PT.	10 cts.
513	2-PT.	10 cts.
126	2-PT.	10 cts.
248	2-PT.	10 cts.
508	2-PT.	10 cts.
68	2-PT.	10 cts.
110	2-PT.	10 cts.
509	2-PT.	10 cts.
111	2-PT.	10 cts.
112	2-PT.	10 cts.
113	2-PT.	10 cts.
114	2-PT.	10 cts.
514	2-PT.	10 cts.
381	2-PT.	10 cts.
468	2-PT.	10 cts.

No.		PER FOOT.
437	2-PT.	12 cts.
115	2-PT.	10 cts.
116	2-PT.	10 cts.
117	2-PT.	12 cts.
510	2-PT.	12 cts.
511	2-PT.	12 cts.
512	2-PT.	12 cts.
118	2-PT.	12 cts.
119	2-PT.	12 cts.
120	2-PT.	12 cts.
121	2-PT.	12 cts.
122	2-PT.	12 cts.
123	2-PT.	12 cts.
124	2-PT.	10 cts.
125	2-PT.	12 cts.
261	2-PT.	12 cts.
266	2-PT.	12 cts.

Can match accurately any single, parallel, double or triple rule shown in any specimen book at regular prices.

BRASS RULES.

No.		PER FOOT.
273	2-PT.	12 cts.
284	2-PT.	12 cts.
289	2-PT.	12 cts.
296	2-PT.	12 cts.
370	2-PT.	12 cts.
50	2-PT.	12 cts.
127	5 TO PICA.	12 cts.
130	5 TO PICA.	12 cts.
128	5 TO PICA.	12 cts.
129	5 TO PICA.	12 cts.
262	5 TO PICA.	15 cts.
267	5 TO PICA.	15 cts.
274	5 TO PICA.	15 cts.
290	5 TO PICA.	15 cts.
297	5 TO PICA.	15 cts.
131	3-PT.	15 cts.
132	3-PT.	15 cts.

No.		PER FOOT.
133	3-PT.	15 cts.
134	3-PT.	15 cts.
135	3-PT.	15 cts.
136	3-PT.	15 cts.
137	3-PT.	15 cts.
145	3-PT.	15 cts.
249	3-PT.	15 cts.
427	3-PT.	15 cts.
426	3-PT.	15 cts.
138	3-PT.	15 cts.
139	3-PT.	15 cts.
441	3-PT.	15 cts.
442	3-PT.	15 cts.
140	3-PT.	18 cts.
141	3-PT.	18 cts.
142	3-PT.	18 cts.
143	3-PT.	18 cts.
144	3-PT.	18 cts.
263	3-PT.	18 cts.

No.		PER FOOT.
268	3-PT.	18 cts.
275	3-PT.	18 cts.
280	3-PT.	18 cts.
285	3-PT.	18 cts.
291	3-PT.	18 cts.
298	3-PT.	18 cts.
303	3-PT.	18 cts.
306	3-PT.	18 cts.
310	3-PT.	18 cts.
314	3-PT.	18 cts.
337	3-PT.	18 cts.
346	3-PT.	18 cts.
371	3-PT.	18 cts.
380	3-PT.	18 cts.
388	3-PT.	18 cts.
391	3-PT.	18 cts.
51	3-PT.	18c.
54	3-PT.	18c.

BRASS RULES.

No.		PER FOOT.
393	3-Pr.	18 cts.
406	3-Pr.	18 cts.
407	3-Pr.	18 cts.
408	3-Pr.	18 cts.
409	3-Pr.	18 cts.
410	3-Pr.	18 cts.
421	3-Pr.	18 cts.
438	3-Pr.	18 cts.
146	4-Pr.	20 cts.
344	4-Pr.	20 cts.
67	4-Pr.	20 cts.
515	4-Pr.	20 cts.
166	4-Pr.	20 cts.
250	4-Pr.	20 cts.
439	4-Pr.	20 cts.
147	4-Pr.	20 cts.
521	4-Pr.	20 cts.
64	4-Pr.	20 cts.

No.		PER FOOT.
148	4-Pr.	20 cts.
531	4-Pr.	20 cts.
149	4-Pr.	20 cts.
150	4-Pr.	20 cts.
151	4-Pr.	20 cts.
152	4-Pr.	20 cts.
526	4-Pr.	20 cts.
153	4-Pr.	20 cts.
154	4-Pr.	20 cts.
155	4-Pr.	22 cts.
156	4-Pr.	22 cts.
157	4-Pr.	22 cts.
158	4-Pr.	22 cts.
159	4-Pr.	22 cts.
160	4-Pr.	22 cts.
161	4-Pr.	22 cts.
162	4-Pr.	22 cts.

No.		PER FOOT.
163	4-Pr.	22 cts.
164	4-Pr.	22 cts.
165	4-Pr.	22 cts.
264	4-Pr.	22 cts.
269	4-Pr.	22 cts.
276	4-Pr.	22 cts.
286	4-Pr.	22 cts.
292	4-Pr.	22 cts.
299	4-Pr.	22 cts.
347	4-Pr.	20 cts.
362	4-Pr.	20 cts.
376	4-Pr.	22 cts.
516	4-Pr.	22 cts.
378	4-Pr.	22 cts.
379	4-Pr.	22 cts.
52	4-Pr.	22 cts.

Can match accurately any single, parallel, double or triple rule shown in any specimen book at regular prices.

BRASS RULES.

No.		PER FOOT.
383	4-Pr.	22 cts.
397	4-Pr.	22 cts.
402	4-Pr.	22 cts.
411	4-Pr.	22 cts.
412	4-Pr.	22 cts.
413	4-Pr.	22 cts.
414	4-Pr.	22 cts.
415	4-Pr.	22 cts.
416	4-Pr.	22 cts.
417	4-Pr.	22 cts.
418	4-Pr.	22 cts.
423	4-Pr.	22 cts.
440	4-Pr.	22 cts.
66 B	4-Pr.	20 cts.
167	5-Pr.	25 cts.

No.		PER FOOT.
450	5-Pr.	25 cts.
251	5-Pr.	25 cts.
168	5-Pr.	25 cts.
169	5-Pr.	25 cts.
170	5-Pr.	25 cts.
171	5-Pr.	25 cts.
172	5-Pr.	25 cts.
173	5-Pr.	25 cts.
174	5-Pr.	27 cts.
175	5-Pr.	27 cts.
176	5-Pr.	27 cts.
422	5-Pr.	27 cts.
177	5-Pr.	27 cts.
178	5-Pr.	25 cts.
55	5-Pr.	27 cts.
56	5-Pr.	27 cts.

No.		PER FOOT.
179	5-Pr.	25 cts.
70	5-Pr.	25 cts.
180	5-Pr.	25 cts.
67 B	5-Pr.	25 cts.
53	5-Pr.	27 cts.
317	5-Pr.	27 cts.
324	5-Pr.	27 cts.
361	5-Pr.	25 cts.
389	5-Pr.	27 cts.
392	5-Pr.	27 cts.
403	5-Pr.	27 cts.
443	5-Pr.	25 cts.
444	5-Pr.	25 cts.
445	5-Pr.	25 cts.
446	5-Pr.	25 cts.
447	5-Pr.	25 cts.
448	5-Pr.	25 cts.

H. C. Hansen obtained Highest Awards for Superior Brass Rule, etc.

BRASS RULES.

No.		PER FOOT.
449	5-Pr.	27 cts.
419	5-Pr.	27 cts.
420	5-Pr.	27 cts.
182	6-Pr.	30 cts.
345	6-Pr.	30 cts.
200	6-Pr.	30 cts.
252	6-Pr.	30 cts.
253	6-Pr.	30 cts.
254	6-Pr.	30 cts.
255	6-Pr.	30 cts.
256	6-Pr.	30 cts.
257	6-Pr.	30 cts.
183	6-Pr.	30 cts.
522	6-Pr.	30 cts.
517	6-Pr.	30 cts.

No.		PER FOOT.
68 B	6-Pr.	30 cts
452	6-Pr.	30 cts.
451	6-Pr.	30 cts.
184	6-Pr.	30 cts.
185	6-Pr.	30 cts.
532	6 Pr.	30 cts.
186	6-Pr.	30 cts.
187	6-Pr.	30 cts.
527	6 Pr.	30 cts.
188	6-Pr.	30 cts.
189	6-Pr.	30 cts.
190	6-Pr.	30 cts.
191	6-Pr.	30 cts.
66	6-Pr.	30 cts.
192	6-Pr.	30 cts.
65	6-Pr.	30 cts.

No.		PER FOOT.
196	6-Pr.	32 cts.
195	6-Pr.	32 cts.
193	6-Pr.	32 cts.
194	6-Pr.	32 cts.
197	6-Pr.	32 cts.
198	6-Pr.	32 cts.
199	6-Pr.	32 cts.
265	6-Pr.	32 cts.
270	6-Pr.	32 cts.
272	6-Pr.	32 cts.
277	6-Pr.	32 cts.
281	6-Pr.	32 cts.
287	6-Pr.	32 cts.
293	6-Pr.	32 cts.
295	6-Pr.	32 cts.

Can match accurately any single, parallel, double or triple rule shown in any specimen book at regular prices.

BRASS RULES.

No.		PER FOOT.
300	6-Pr.	32 cts.
304	6-Pr.	32 cts.
307	6-Pr.	32 cts.
311	6-Pr.	32 cts.
315	6-Pr.	32 cts.
323	6-Pr.	32 cts.
326	6-Pr.	32 cts.
327	6-Pr.	32 cts.
328	6-Pr.	32 cts.
338	6-Pr.	32 cts.
340	6-Pr.	32 cts.
348	6-Pr.	30 cts.
353	6-Pr.	30 cts.
356	6-Pr.	30 cts.
61	6-Pr.	32 cts.

No.		PER FOOT.
366	6-Pr.	32 cts.
367	6-Pr.	32 cts.
372	6-Pr.	32 cts.
373	6-Pr.	32 cts.
374	6-Pr.	32 cts.
377	6-Pr.	32 cts.
390	6-Pr.	32 cts.
394	6-Pr.	32 cts.
398	6-Pr.	32 cts.
400	6-Pr.	32 cts.
404	6-Pr.	32 cts.
424	6-Pr.	32 cts.
425	6-Pr.	32 cts.
58	6-Pr.	32 cts.
59	6-Pr.	32 cts.
57	6-Pr.	32 cts.

No.		PER FOOT.
453	7-Pr.	35 cts.
464	7-Pr.	35 cts.
454	7-Pr.	35 cts.
455	7-Pr.	35 cts.
69 B	7-Pr.	35 cts.
60	7-Pr.	40 cts.
456	7-Pr.	35 cts.
457	7-Pr.	35 cts.
458	7-Pr.	35 cts.
459	7-Pr.	35 cts.
460	7-Pr.	35 cts.
461	7-Pr.	35 cts.
462	7-Pr.	40 cts.
463	7-Pr.	40 cts.
201	8-Pr.	40 cts.

BRASS RULES.

No.		PER FOOT.
221	8-Pr.	40 cts.
258	8-Pr.	40 cts.
202	8-Pr.	40 cts.
523	8-Pr.	40 cts.
518	8-Pr.	40 cts.
70 B	8-Pr.	40 cts.
203	8-Pr.	40 cts.
204	8-Pr.	40 cts.
205	8-Pr.	40 cts.
206	8-Pr.	40 cts.
533	8 Pr.	40 cts.
207	8-Pr.	40 cts.
528	8 Pr.	40 cts.
208	8-Pr.	40 cts.

No.		PER FOOT.
209	8-Pr.	40 cts.
210	8-Pr.	40 cts.
211	8-Pr.	40 cts.
212	8-Pr.	40 cts.
259	8-Pr.	40 cts.
213	8-Pr.	40 cts.
214	8-Pr.	40 cts.
215	8-Pr.	40 cts.
216	8-Pr.	42 cts.
217	8-Pr.	42 cts.
218	8-Pr.	42 cts.
219	8-Pr.	42 cts.
220	8-Pr.	42 cts.

No.		PER FOOT.
278	8-Pr.	42 cts.
301	8-Pr.	42 cts.
318	8-Pr.	42 cts.
321	8-Pr.	42 cts.
322	8-Pr.	42 cts.
325	8-Pr.	42 cts.
357	8-Pr.	40 cts.
362	8-Pr.	40 cts.
368	8-Pr.	42 cts.
395	8-Pr.	42 cts.
399	8-Pr.	42 cts.
466	8-Pr.	40 cts.
467	8-Pr.	40 cts.
469	9-Pr.	45 cts.

Can match accurately any single, parallel, double or triple rule shown in any specimen book at regular prices.







BRASS RULES.





No.		PER FOOT.
476	9-Pr.	45 cts.
470	9-Pr.	45 cts.
471	9-Pr.	45 cts.
472	9-Pr.	45 cts.
473	9-Pr.	45 cts.
474	9-Pr.	50 cts.
475	9-Pr.	50 cts.
538	8-Pr.	50 cts.
222	10-Pr.	50 cts.
232	10-Pr.	50 cts.
223	10-Pr.	50 cts.
224	10-Pr.	50 cts.
225	10-Pr.	50 cts.
226	10-Pr.	50 cts.



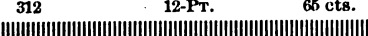
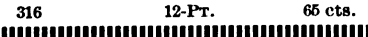
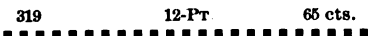
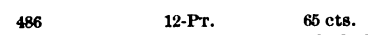



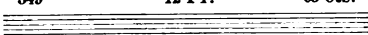
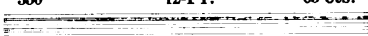

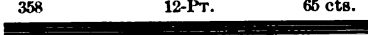
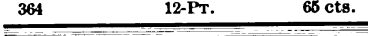
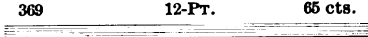
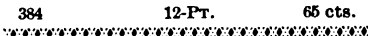
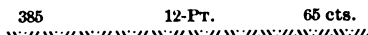
No.		PER FOOT.
534	10-Pr.	50 cts.
529	10-Pr.	50 cts.
227	10-Pr.	50 cts.
524	10-Pr.	50 cts.
519	10-Pr.	50 cts.
228	10-Pr.	50 cts.
229	10-Pr.	55 cts.
230	10-Pr.	55 cts.
231	10-Pr.	55 cts.
539	10-Pr.	55 cts.
363	10-Pr.	50 cts.
478	10-Pr.	50 cts.
479	10-Pr.	50 cts.
62	10-Pr.	55 cts.

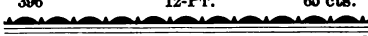
No.		PER FOOT.
233	12-Pr.	60 cts.
240	12-Pr.	60 cts.
483	12-Pr.	60 cts.
482	12-Pr.	60 cts.
234	12-Pr.	60 cts.
235	12-Pr.	60 cts.
236	12-Pr.	60 cts.
237	12-Pr.	65 cts.
238	12-Pr.	65 cts.
487	12-Pr.	65 cts.
239	12-Pr.	65 cts.
271	12-Pr.	65 cts.

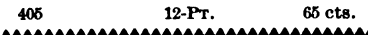
BRASS RULES.

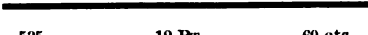







No.		PER FOOT.
279	12-Pr.	65 cts.
		
282	12-Pr.	65 cts.
		
288	12-Pr.	65 cts.
		
294	12-Pr.	65 cts.
		
302	12-Pr.	65 cts.
		
305	12-Pr.	65 cts.
		
308	12-Pr.	65 cts.
		
312	12-Pr.	65 cts.
		
316	12-Pr.	65 cts.
		
319	12-Pr.	65 cts.
		
486	12-Pr.	65 cts.
		









No.		PER FOOT.
333	12-Pr.	65 cts.
		
339	12-Pr.	65 cts.
		
341	12-Pr.	65 cts.
		
349	12-Pr.	65 cts.
		
350	12-Pr.	65 cts.
		
354	12-Pr.	65 cts.
		
358	12-Pr.	65 cts.
		
364	12-Pr.	65 cts.
		
369	12-Pr.	65 cts.
		
384	12-Pr.	65 cts.
		
385	12-Pr.	65 cts.
		





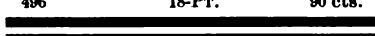

No.		PER FOOT.
386	12-Pr.	65 cts.
		
396	12-Pr.	65 cts.
		
401	12-Pr.	65 cts.
		
405	12-Pr.	65 cts.
		
525	12-Pr.	60 cts.
		
520	12-Pr.	60 cts.
		
535	12 Pr.	60 cts.
		
530	12 Pr.	60 cts.
		
540	12-Pr.	65 cts.
		
63	12-Pr.	65 cts.
		

Can match accurately any single, parallel, double or triple rule shown in any specimen book at regular prices.

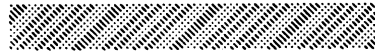
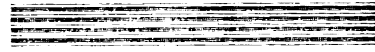



BRASS RULES.



No.		PER FOOT.
329	12-Pr.	65 cts.
		
330	12-Pr.	65 cts.
		
331	12-Pr.	65 cts.
		
332	12-Pr.	65 cts.
		
536	15-Pr.	75 cts.
		
537	15-Pr.	75 cts.
		
241	18-Pr.	90 cts.
		
245	18-Pr.	90 cts.
		
242	18-Pr.	90 cts.
		

No.		PER FOOT.
243	18-Pr.	90 cts.
		
497	18-Pr.	90 cts.
		
244	18-Pr.	90 cts.
		
498	18-Pr.	90 cts.
		
496	18-Pr.	90 cts.
		
309	18-Pr.	95 cts.
		
320	18-Pr.	95 cts.
		
334	18-Pr.	95 cts.
		
335	18-Pr.	95 cts.
		

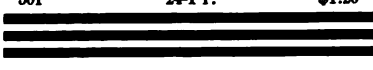
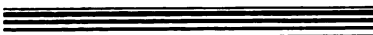

No.		PER FOOT.
336	18-Pr.	95 cts.
		
342	18-Pr.	95 cts.
		
351	18-Pr.	95 cts.
		
355	18-Pr.	95 cts.
		
494	18-Pr.	95 cts.
		
359	18-Pr.	95 cts.
		
360	18-Pr.	95 cts.
		
365	18-Pr.	95 cts.
		
375	18-Pr.	95 cts.
		







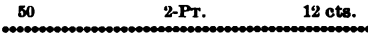
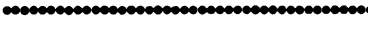

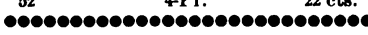
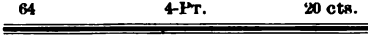
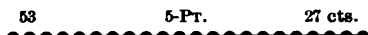

BRASS RULES.

No.		PER FOOT.
493	15-PT.	80 cts.
		
499	18-PT.	95 cts.
		
387	18-PT.	95 cts.
		
501	24-PT.	\$1.20
		
502	24-PT.	\$1.20
		
503	24-PT.	\$1.25
		
504	24-PT.	\$1.25
		

No.		PER FOOT.
505	24-PT.	\$1.20
		
506	24-PT.	\$1.20
		
507	24-PT.	\$1.20
		

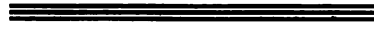
New Brass Rules

No.		PER FOOT.
50	2-PT.	12 cts.
		
51	3-PT.	18 cts.
		
54	3-PT.	18 cts.
		
52	4-PT.	22 cts.
		
64	4-PT.	20 cts.
		
53	5-PT.	27 cts.
		

No.		PER FOOT.
55	5-PT.	27 cts.
		
56	5-PT.	27 cts.
		
58	6-PT.	32 cts.
		
59	6-PT.	32 cts.
		
57	6-PT.	32 cts.
		
61	6-PT.	32 cts.
		
66	6-PT.	30 cts.
		
65	6-PT.	30 cts.
		
60	7-PT.	40 cts.
		
62	10-PT.	55 cts.
		
63	12-PT.	65 cts.
		

Can match accurately any single, parallel, double or triple rule shown in any specimen book at regular prices.

LABOR-SAVING BRASS RULES.

These Rules are put up in Fonts of 3 pounds or more.

SCHEME FOR LABOR-SAVING BRASS RULE.

12 pieces each length, 1, 1½, 2, 2½, 3, 3½, 4, 4½, 5, 5½, and 6 ems 12-Pt.; 10 pieces each length, 7, 8, 9, 10, 11, 12, 13, 14, 15 and 16 ems; 6 pieces each length, 17, 18, 19, 20, 21, 22, 23, 24, 25 and 26 ems; 4 pieces each length, 27, 28, 29, 30, 31, 32, 33, 34, 35 and 36 ems; 96 mitered corner pieces, or two sets each length, 2, 2½, 3, 3½, 4 and 4½ ems 12-Pt. outside measure

Point	Per lb.
1	\$ 2.50
1½	2.00
2	1.75
3	1.60
4	1.50
5	1.50
6-Pt. and over \$1.50 per lb.	

LABOR-SAVING FONTS MADE TO ORDER.

Any size fonts of Labor-Saving Brass Rule put up to order from any rule shown in Specimens. Select rule desired, and give the number of each length wanted when ordering.

Rule cut to 12-point ems in length unless otherwise ordered.

Special prices for large quantities.

No. 113.

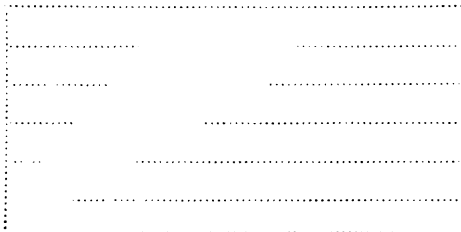

One Font put up by the above Scheme will weigh about 6 lbs.

No. 109.



One Font put up by the above Scheme will weigh about 6 lbs.

No. 152.

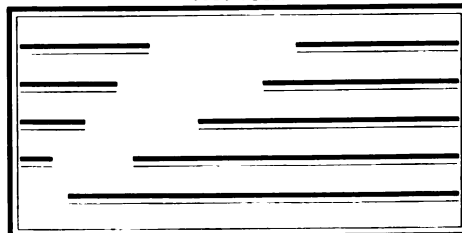

One Font put up by the above Scheme will weigh about 12 lbs.

No. 147.

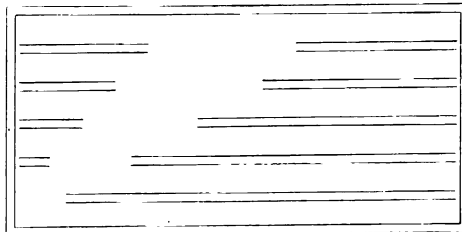

One Font put up by the above Scheme will weigh about 12 lbs.

LABOR-SAVING BRASS RULES

2-Pt. Body, 1-Pt. Face on side. No. 508

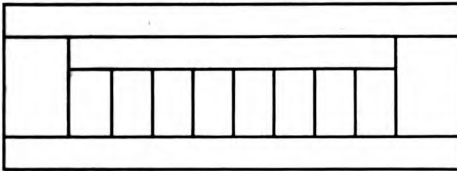

2-Pt. Face and Body. No. 126

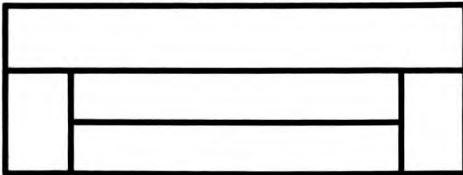

3-Pt. Face and Body. No. 145



These rules put up in fonts as described on opposite page

PRICES

	BODY	
5 lb. font,	1-pt.	\$12.00
" "	2 "	8.25
" "	3 "	7.50
" "	4 "	7.00
" "	5 "	7.00
" "	6 "	7.00
" "	7 "	7.00
" "	8 "	7.00

3-Pt. Parallel. No. 441

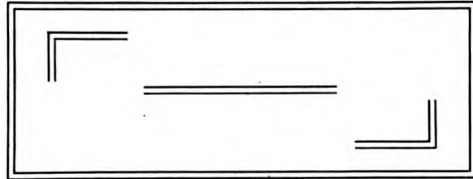

4-Pt. Parallel. No. 521

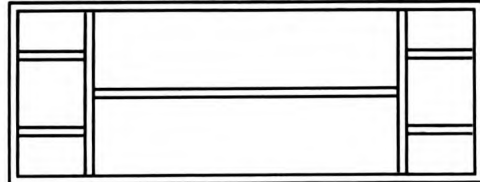

6-Pt. No. 65

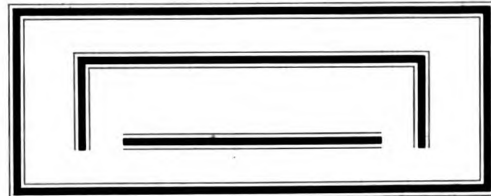

We make hundreds of Special Designs to order.

Any rule face put up in labor-saving fonts. We can match accurately any single, dotted, parallel, double or triple rules shown in any specimen book at regular prices.

BRASS TRADE SIGNS 50c. each.

Order by number



No. 152. 4-PT.

No. 147. 4-PT.

MITERED

LABOR-SAVING

BRASS

RULES.

THESE Rules are made in fonts containing 50 sets of Rules; or 4 Pieces each length, from one to fifty ems pica, each piece being mitered on both ends and numbered 12-Pt. ems inside measure.

PRICES.

Per Font		Per Font	
2-Point Rule . .	\$12.50	6-Point Rule . .	\$28.00
3 " " . .	15.75	8 " " . .	36.00
4 " " . .	19.75	10 " " . .	43.00
5 " " . .	23.50	12 " " . .	52.00

H. C. HANSEN,

BOSTON,

MASS.

No. 420. 5-PT.

No. 521. 4-PT.

BRASS CIRCLES

Circles and Ovals any size or face made to order.

We make parallel brass rules to match these circles.

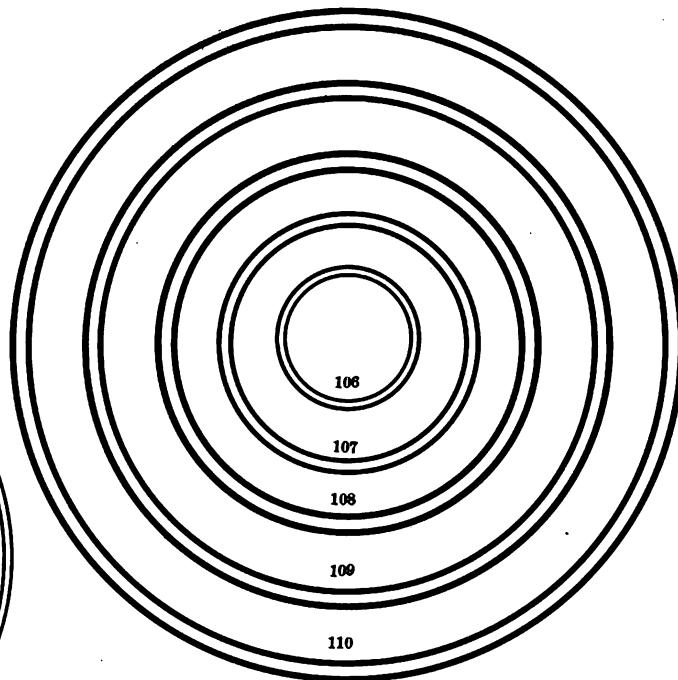
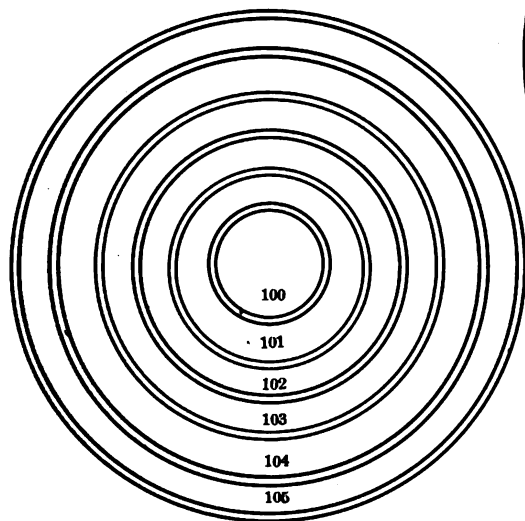

No. 100.....	35 cts.	No. 106.....	\$ 35 cts.
" 101.....	50 "	" 107.....	50 "
" 102.....	50 "	" 108.....	60 "
" 103.....	60 "	" 109.....	80 "
" 104.....	75 "	" 110.....	1.00 "
" 105.....	80 "		

BRASS CIRCLES.

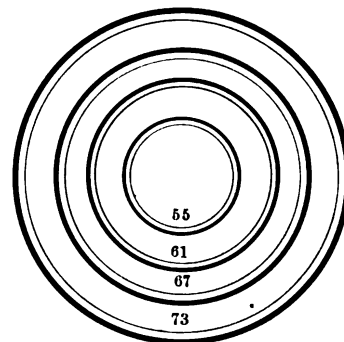
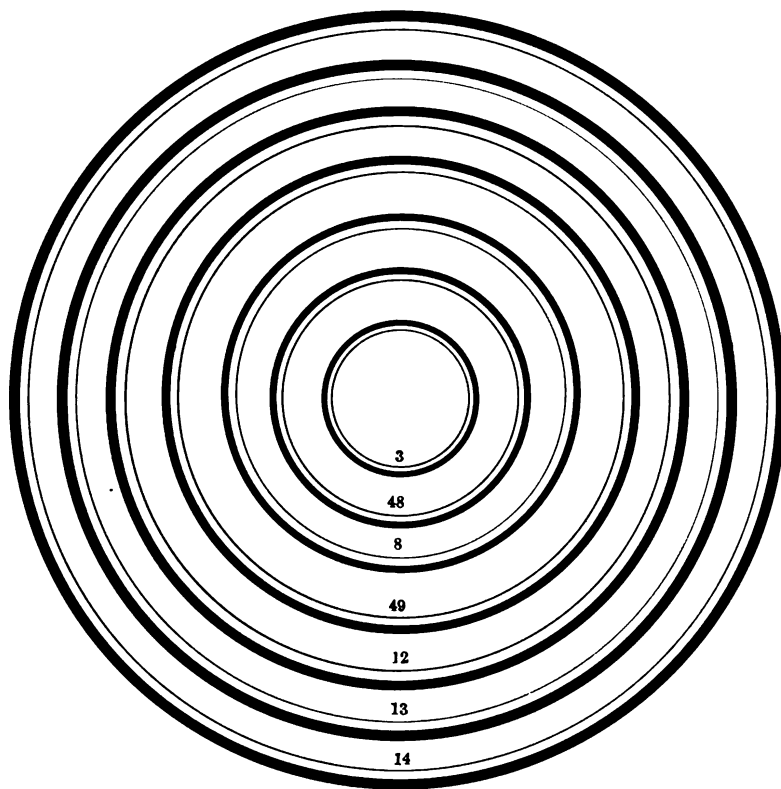

No. 14	\$1.00 each.
" 4960 "
Nos. 12 and 1375 "
" 3, 50, 55, 56 and 6135 "
" 8, 48, 62, 67, 68, 73 and 7450 "

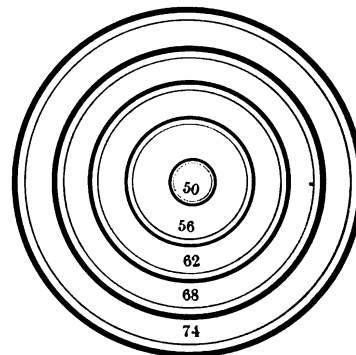

BRASS CIRCLES.

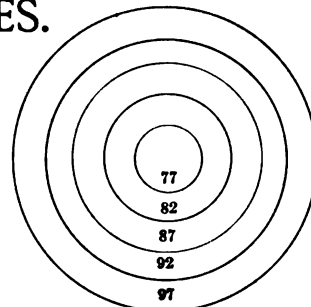
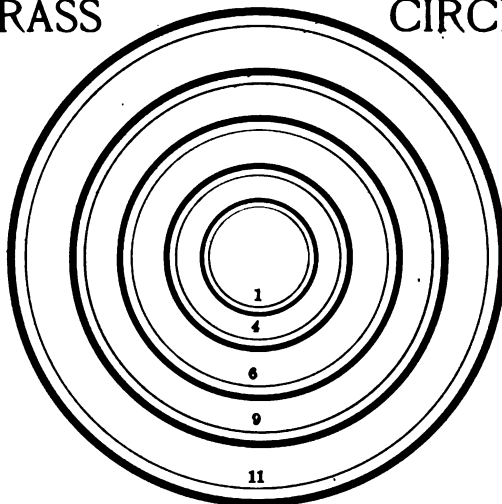
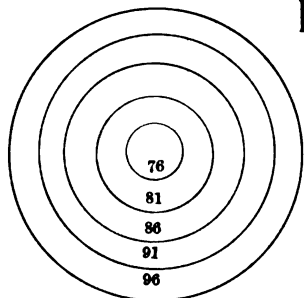

No.	Price.	No.	Price.
1	35 cts.	78	35 cts.
4	35 "	79	35 "
6	50 "	80	35 "
9	60 "	81	35 "
11	60 "	82	35 "
75	35 "	83	35 "
76	35 "	84	35 "
77	35 "	85	35 "

No.	Price.	No.	Price.
86	35 cts.	93	50 cts.
87	50 "	94	50 "
88	50 "	95	50 "
89	50 "	96	50 "
90	50 "	97	50 "
91	50 "	98	50 "
92	50 "	99	50 "

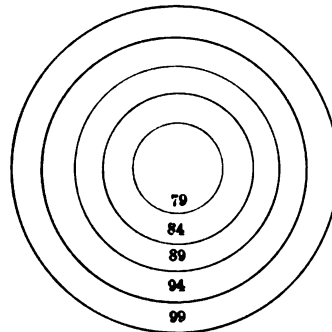
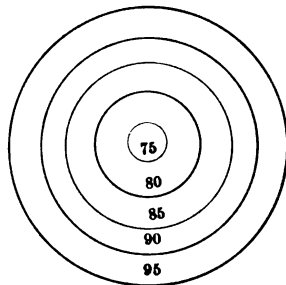
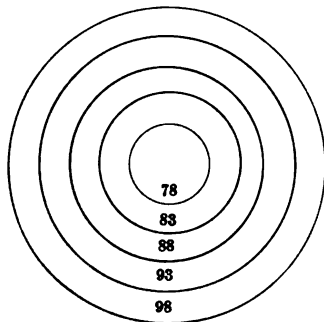

BRASS CIRCLES.

Circles and Ovals of any Size or Face, Made to Order.

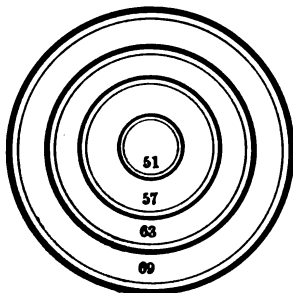

No.	Price.
51	35 cts.
52	35 "
53	35 "
54	35 "
57	35 "
58	35 "
59	35 "
60	35 "

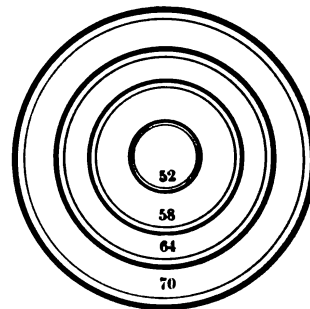

No.	Price.
63	50 cts.
64	50 "
66	50 "
66	50 "
69	50 "
70	50 "
71	50 "
72	50 "

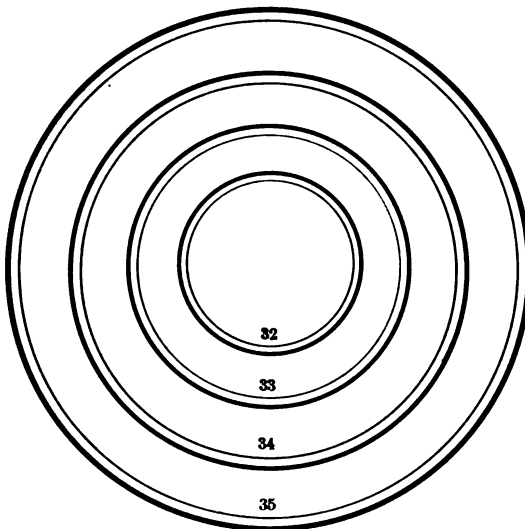

No.	Price.
32	40 cts.
33	50 "
34	60 "
35	75 "

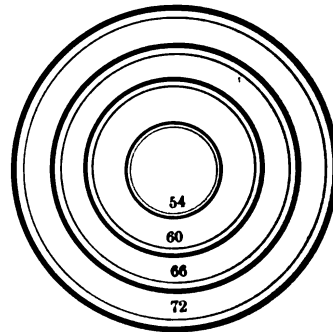
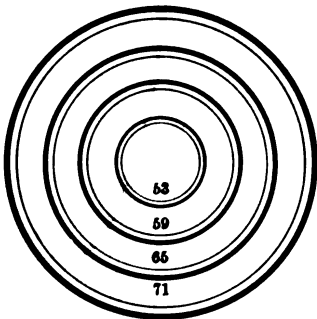

BRASS OVALS.

Ovals of any Size or Face, Made to Order.

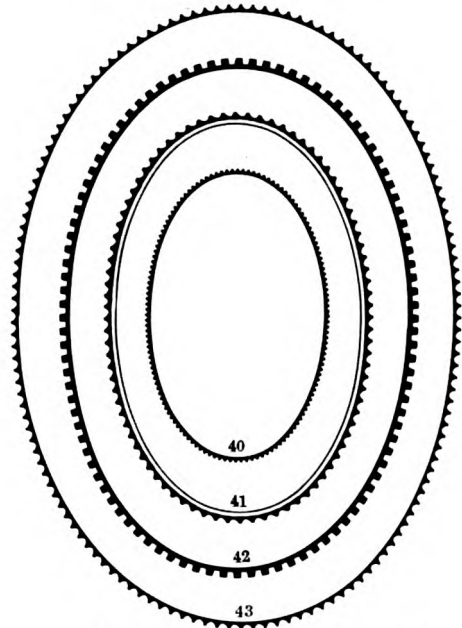
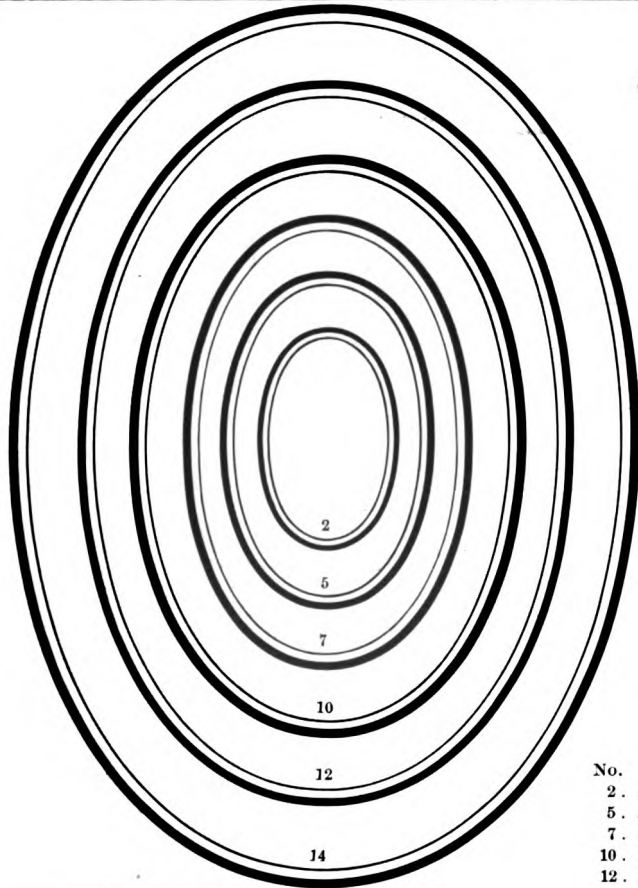

No.	Price.	No.	Price.
2	\$.50	14	\$1.15
570	4075
775	4190
1075	42	1.00
1290	43	1.15

BRASS OVALS.

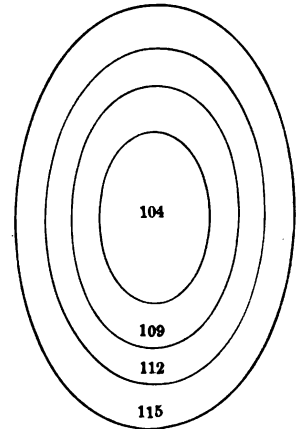
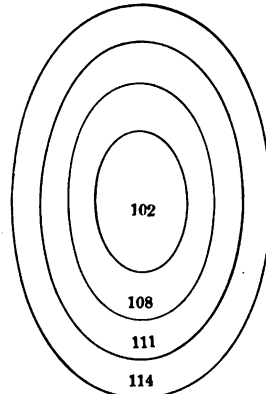
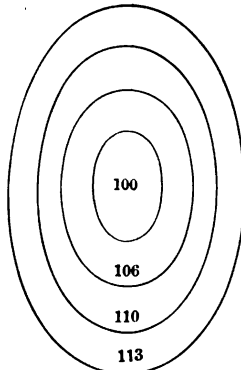
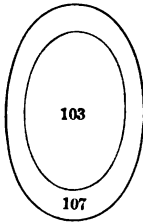
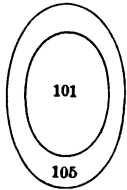

Nos. 100 to 110, and 116 to 126,
50 cents each.

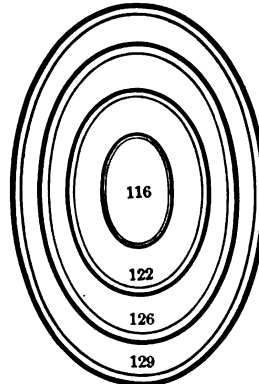
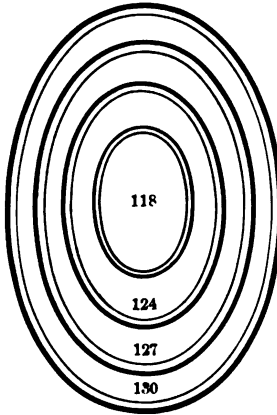
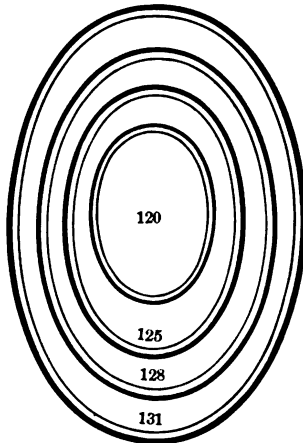

Nos. 111 to 115, and 127 to 131,
70 cents each.

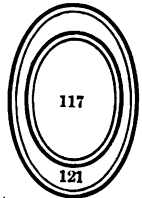
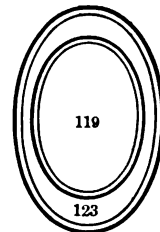

BRASS CIRCLES

AND OVALS.

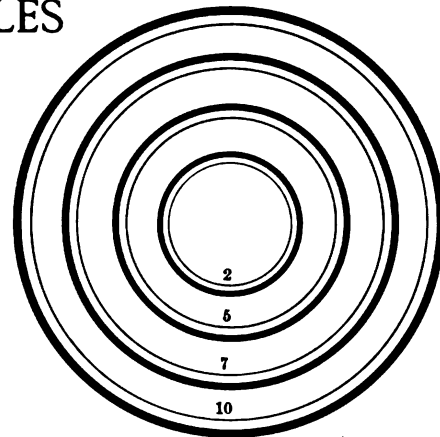
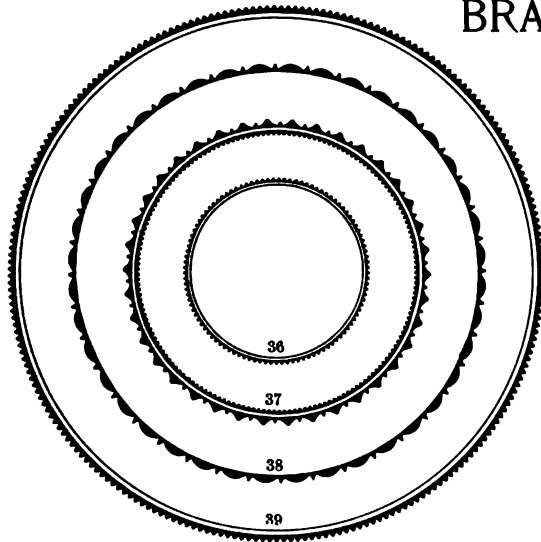

No.	Price.
2	\$.35
550
750
1060
1595
16	1.15
2075
2475
2585
2695
3085
3660
3775
3875
39	1.00

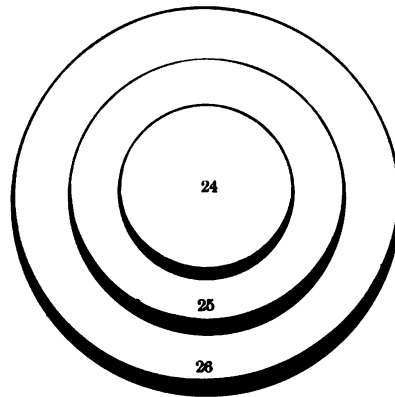
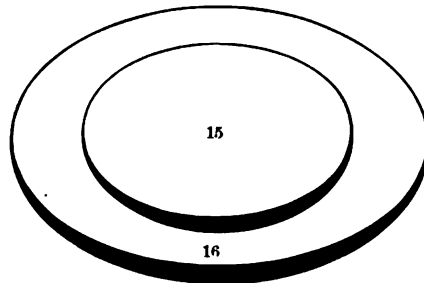
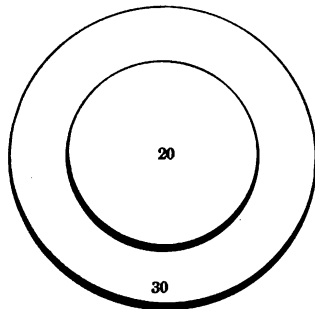

BRASS OVALS.

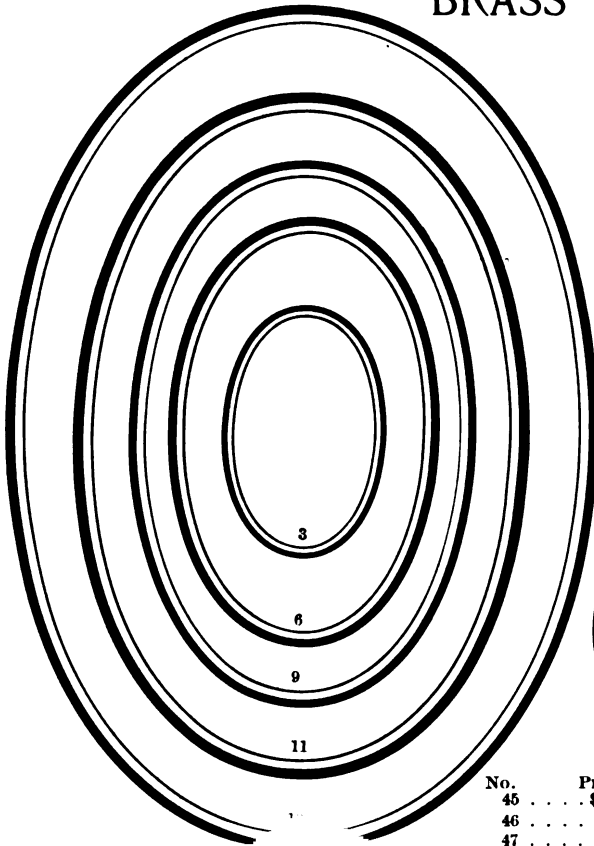

No.	Price.
45	\$.50
4675
4775

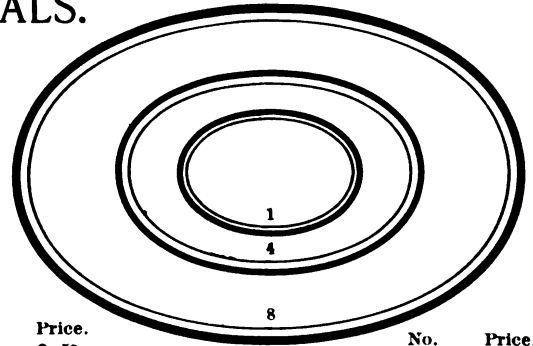

No.	Price.
1	\$.50
350
450
670

No.	Price.
9	\$.75
1190
13	1.00
4450

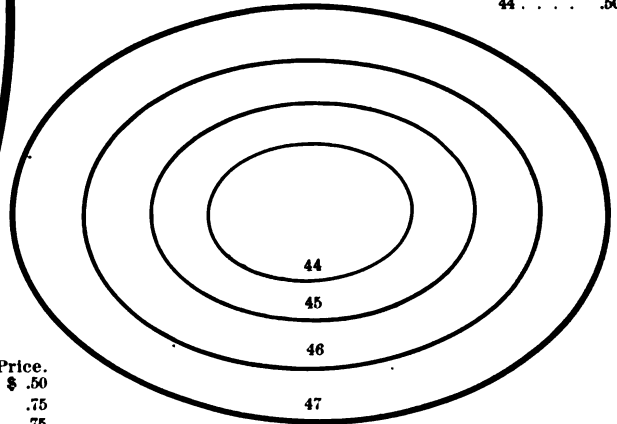

BRASS OVALS

No.	Price	No.	Price
50.....	\$.70	55.....	\$.80
51.....	.70	56.....	1.00
52.....	.80	57.....	1.25
53.....	.90		
54.....	1.15		

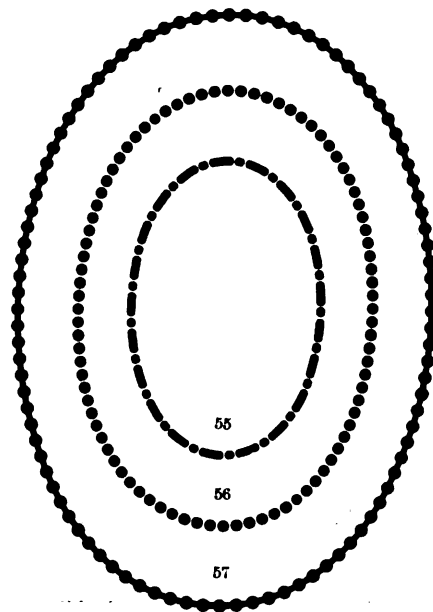
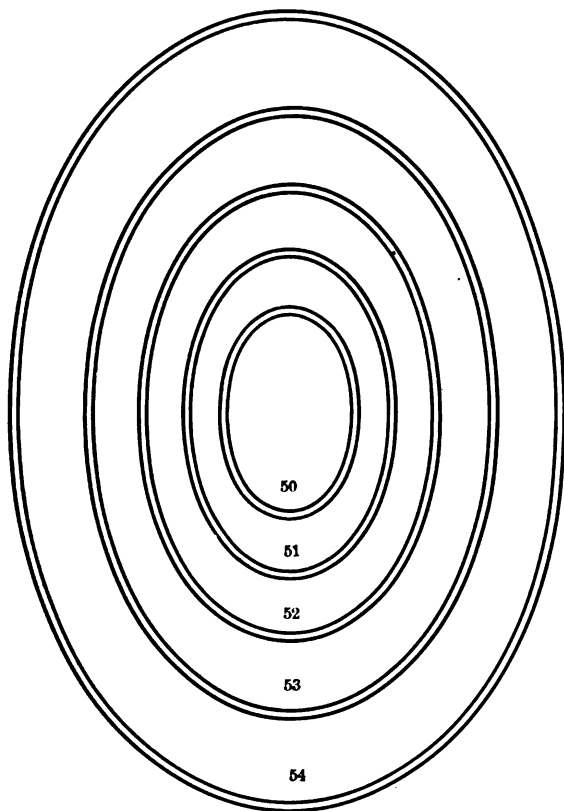

Any size Oval made to order.

HANSEN'S SQUARE SOLID BRASS CORNERS**Invaluable for Newspaper and Job Offices.**

Square Corners 50 cents a set of four.



Round Corners 50 cents a set.



30c. a pair.

BRASS CENTER PIECES, 50 CENTS A PAIR.

30 cents a pair.

H. C. Hansen received Highest Award for
Superior Type and Brass Rule.

The above Brass Corners are made to match 2, 3, 4, 5, 6, 8, 10 and 12-Point Brass Rule. The Brass Rule can be furnished in strips or in labor-saving fonts. They are easily handled, and resist the wear and tear of stereotyping indefinitely. We only show two faces of corners, numbers 24, 25, 26 and 27, but can make to order any other combination of faces. Other combination of faces similar to corner No. 33 are made to order. They are all mortised and made from solid brass rule and not soldered.

NEW
BRASS
CORNERS

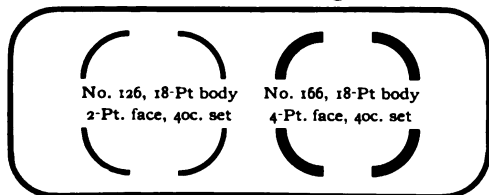
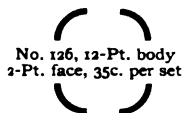
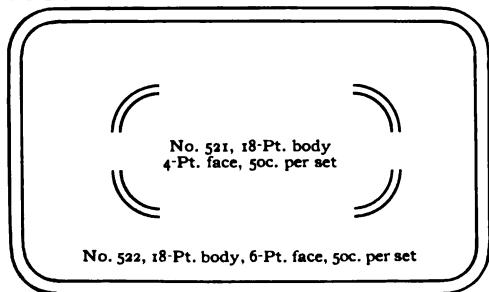

No. 200. 18-Pt. body, 6-Pt. face, 40c. per set

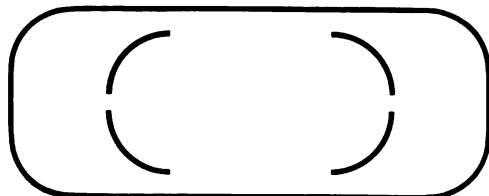

No. 126, 24-Pt. body, 2-Pt. face, 50c. per set.

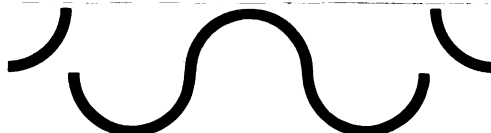

No. 166, 24-Pt. body, 4-Pt. face, 50c. per set

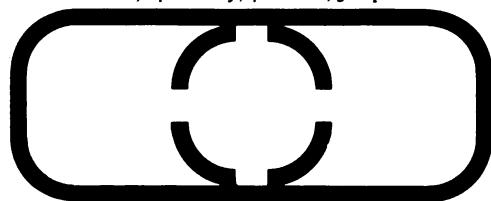

No. 200, 24-Pt. body, 6-Pt. face, 50c. per set

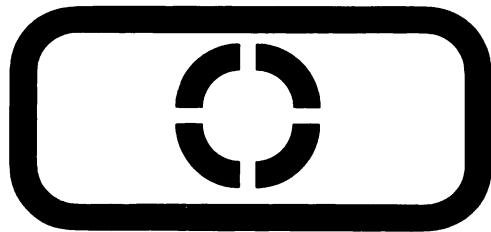

No. 232, 24-Pt. body, 10-Pt. face, 50c. per set

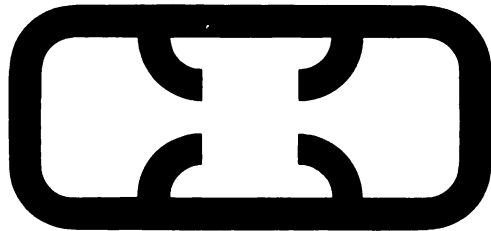

No. 240, 24-Pt. body, 12-Pt. face, 50c. per set

The corners shown here are made on solid brass, on 12, 18 and 24-Pt. body, and justified easily as type, spaces and quads. Numbers of each correspond to the face of the rule which is to be used

BRASS DASHES, Cut to Single Column, 8 cents each.

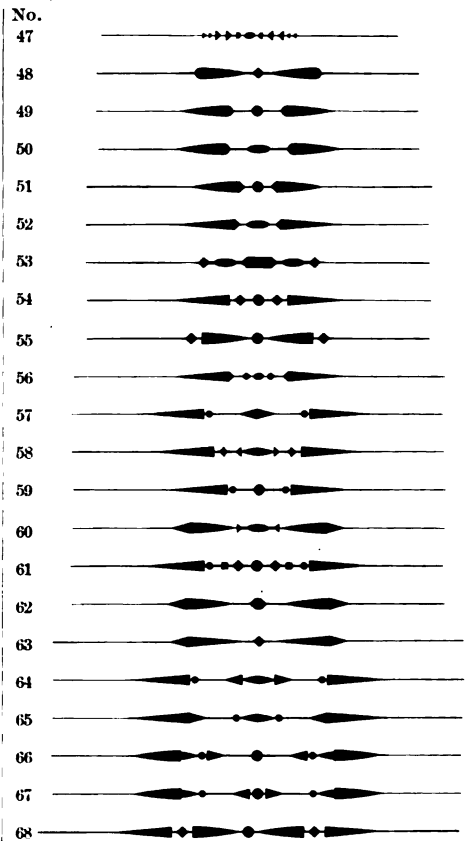
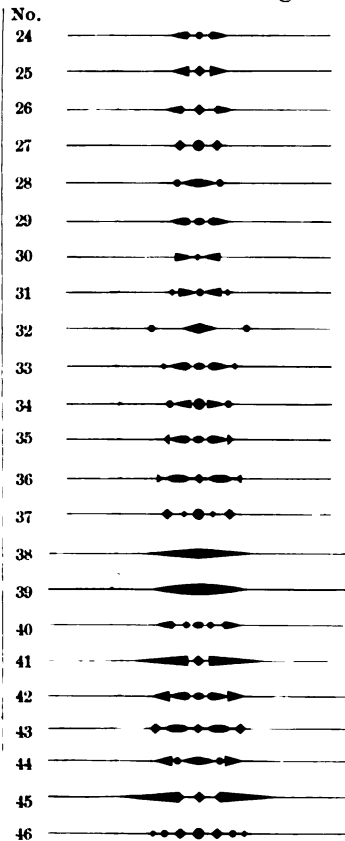
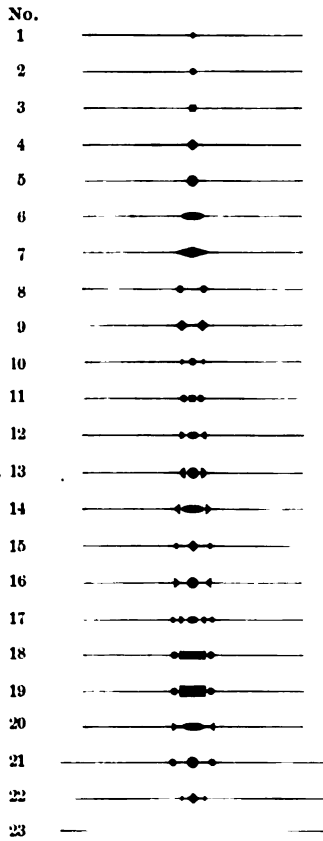

BRASS DASHES. Cut to Single Column.

No. 138 to 171, inclusive, 6 cents each.

Nos. 120 to 137, 8 cents each.

Nos. 69 to 75, 20 cents each.

No.	Image
138	
139	
140	
141	
142	
144	
145	
146	
147	
149	
151	
153	
156	
158	
160	
162	
164	
166	
168	
170	

No.	Image
120	
121	
122	
123	
124	
125	
126	
127	

No.	Image
129	
130	
131	
132	
133	
134	
135	
136	
137	

69	
70	
71	
72	
73	
74	
75	

BRASS JOB DASHES, ON 2-POINT BODY. Price, 5 cents each.

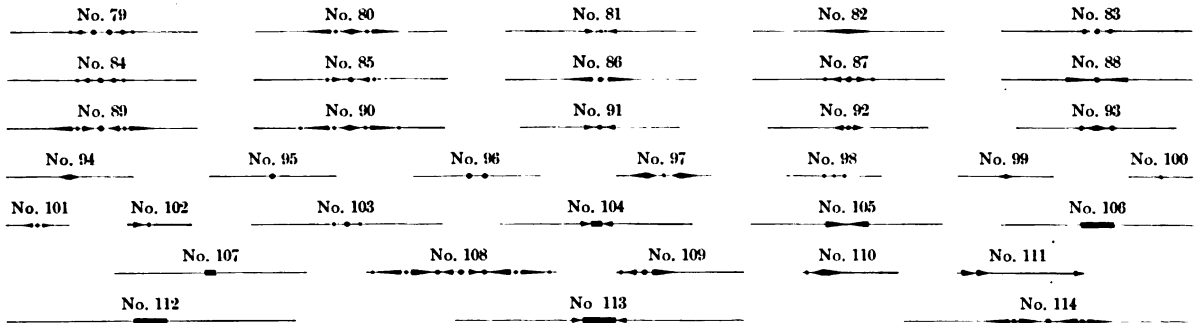

SOLID BRASS ROUND CORNERS.

24-Point, 50 cts. per set.

18-Point, 40 cts. per set.

12-Point 35 cts. per set

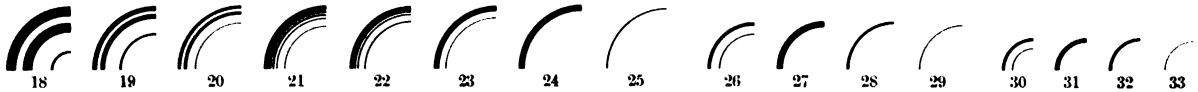

BRASS DASH CORNERS. Per set of four, 50 cents

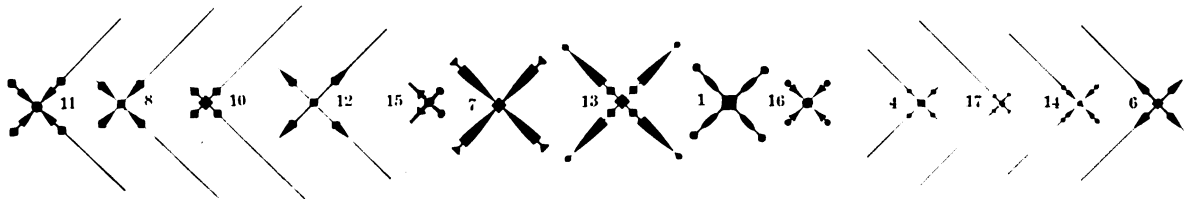

Nos. 18 to 43, 10 cents each.

BRASS FLOURISHES.

Nos. 61 to 75, 5 cents each

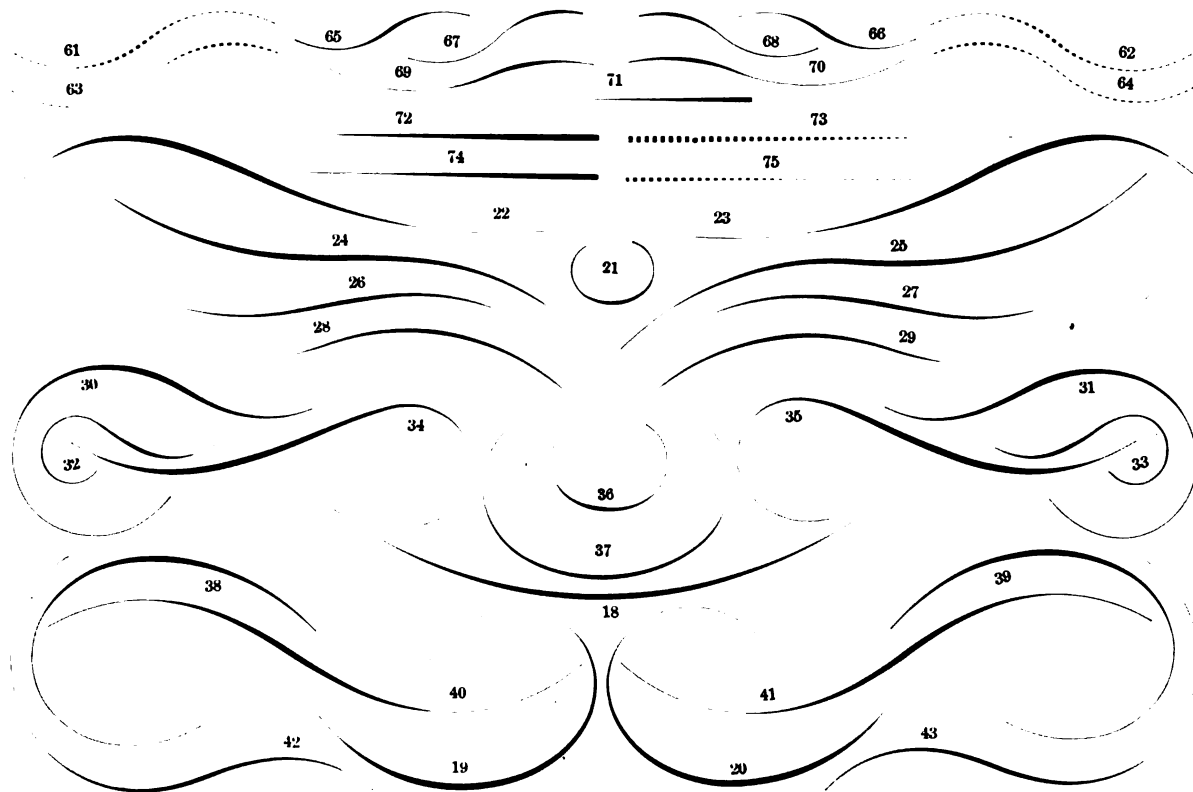

BRASS BRACES AND HALF BRACES.

1 to 12—12 cents.

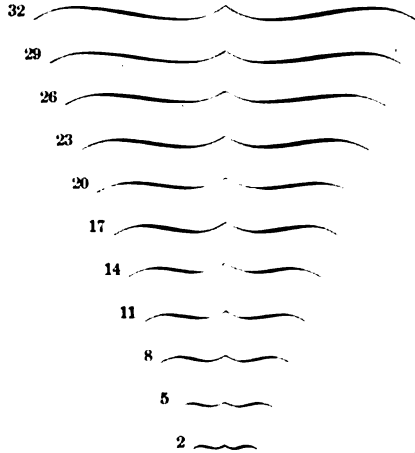

MADE ON 6-POINT BODY.
13 to 24—15 cents.

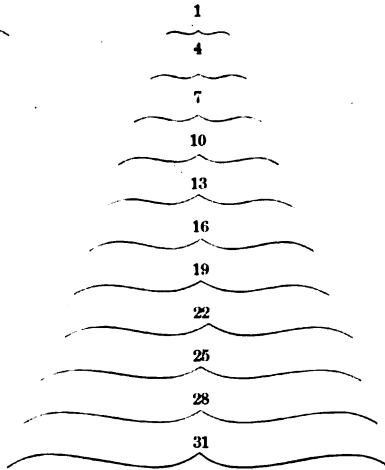

25 to 33—20 cents.

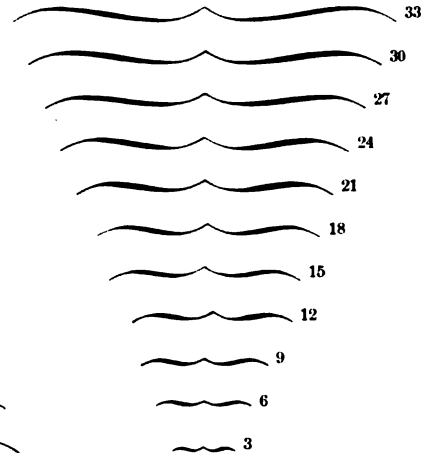

34 to 41—6 cents.

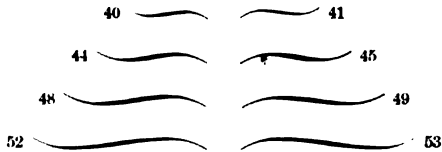

42 to 49—8 cents.



50 to 55—10 cents.

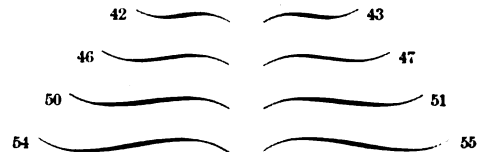

BRASS CLAMPS FOR CURVED LINES.

METAL CORNER QUADS.

6-Point, 10 cts. per set.
8 " 10 " " "
10-Point, 12 cts. per set.
12 " 12 " " "



BRASS CORNER QUADS.

Perfectly Square Inside
and Outside.
35 cents per set.
6 and 12 Pt.
Shown Full Size.



6-Pt.



12-Pt.

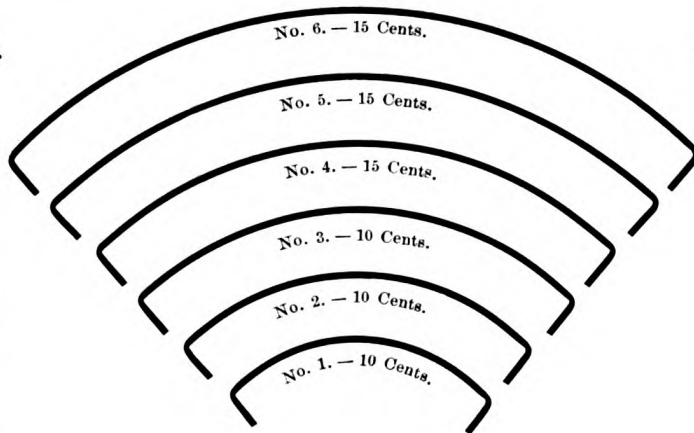

No. 6. — 15 Cents.

No. 5. — 15 Cents.

No. 4. — 15 Cents.

No. 3. — 10 Cents.

No. 2. — 10 Cents.

No. 1. — 10 Cents.

LABOR-SAVING BRASS LEADERS.

Printers will readily see the economy of having Leaders made from solid brass.
Fonts of five pounds or more, cut to en, em, 2, 3, 4 and 6 ems in length, at \$1.50 per pound.

6-Point.



8-Point.



10-Point.



11-Point.



Leaders also made on any other body to line with any face.

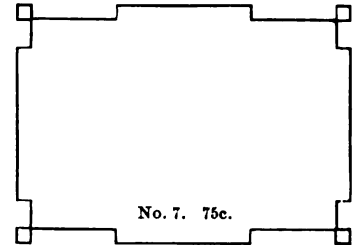
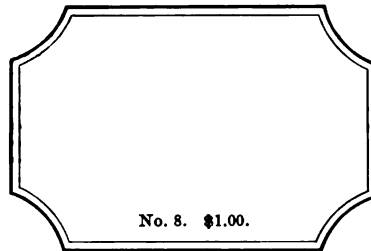
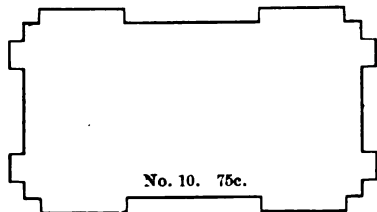
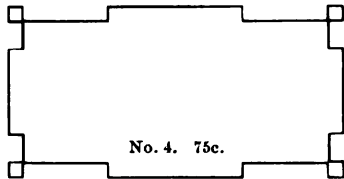
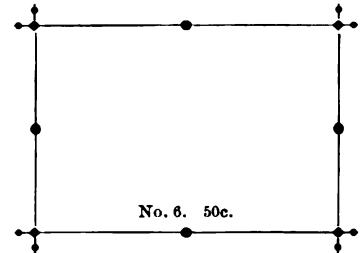
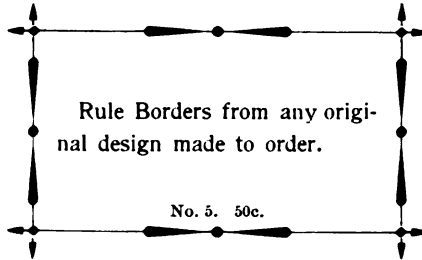
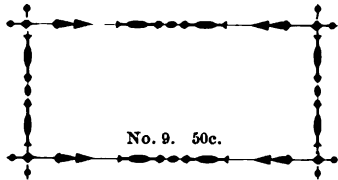
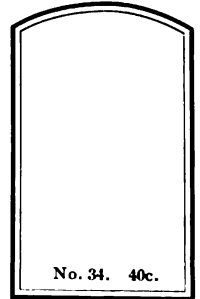
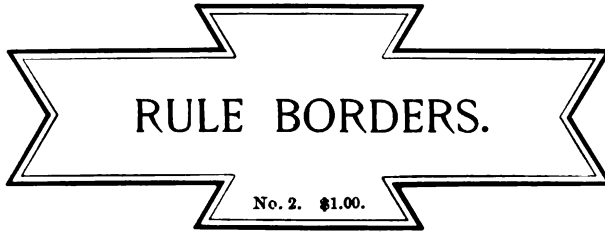
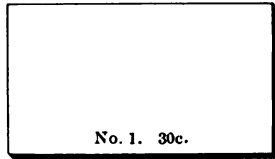

RULE BORDERS.

Rule Borders
from any original
design made
to order.

No. 30. 75c.

No. 31. \$1.00.

No. 27. 70c.

No. 28. 80c.

No. 17. 30c.

No. 18. 40c.

No. 25. 50c.

No. 26. 75c.

No. 37.
75c.

No. 38.

\$1.00

No. 16. 50c.

No. 23. 50c.

No. 32. 50c.

No. 15. 50c.

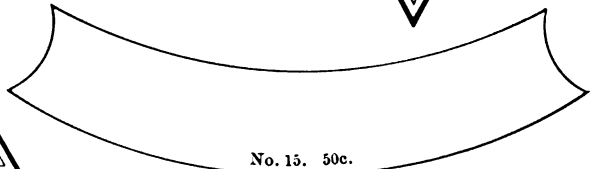
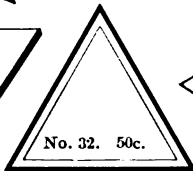
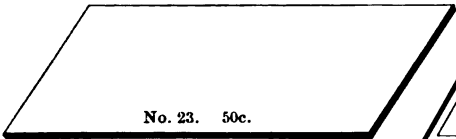
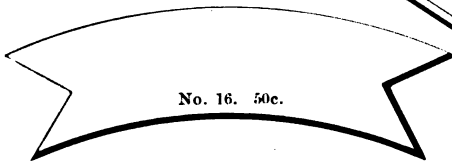
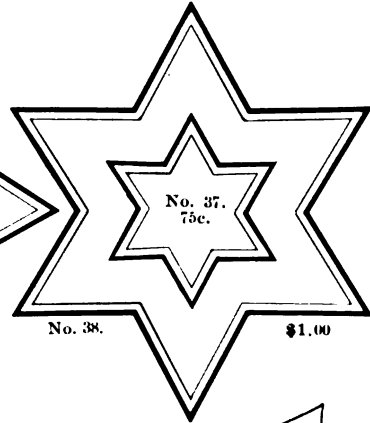
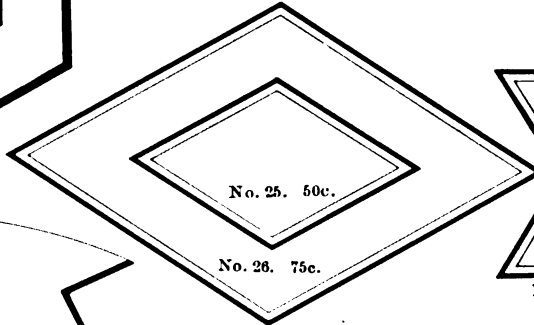
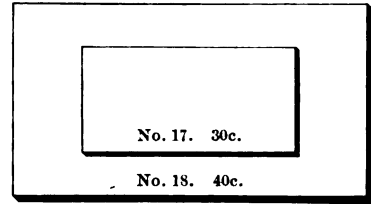
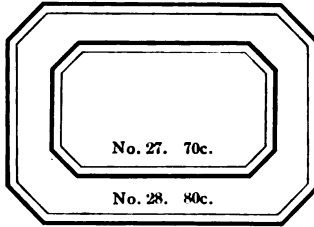
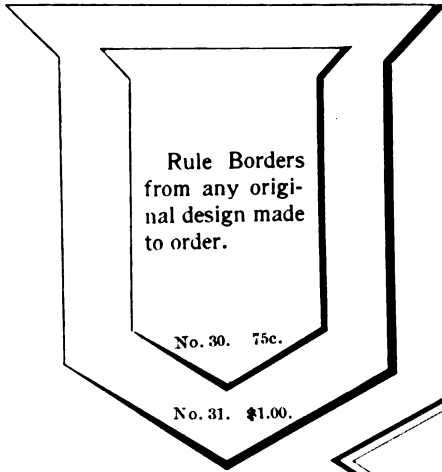

FRENCH OLD STYLE

6-POINT FRENCH OLD STYLE.

To China, the birthplace of so many of the useful arts and inventions, we must look for the origin of the "art preservative." Early in the tenth century, five hundred years before Gutenberg contrived the movable metal types which have rendered his name imperishable, an imperial edition of the sacred books was published in that far oriental country. But on the same principal that the glory of America's discovery rests with Columbus and not with Lief Ericson, must the honor of the most powerful factor in civilization be ascribed to Gutenberg and his contemporaries.

No advancement commercially or politically of the civilized nations of Western Europe resulted from the discovery of America by the Norsemen, and had these early explorers exerted themselves to permanently colonize the western hemisphere, their semi-barbarous character affords no indication that civilization would have been promoted by their conquests. So, had the knowledge of printing remained the sole property of the inhabitants of the Flowery Kingdom and neighboring countries, the progress of civilization would have been retarded centuries, as it was not until a comparatively recent date that western energy and perseverance succeeded in penetrating their exclusiveness and in acquainting us with their peculiar customs and modes of living. The history of printing properly begins with the employment of movable types by Europeans.

Few inventions are the spontaneous conceptions of individual minds. An invention is generally the climax to a series of efforts of different individuals at different times, and the inventor is he who embodies the

PRACTICE OF INTRODUCING GOOD DRAWINGS

12345 abcdefghijklmnopqrstuvwxyz 67890

Lower case a to z 14 1/4 ems.

ABCDEFGHIJKLMNPOQRSTUVWXYZÆOE&

To China, the birthplace of so many of the useful arts and inventions, we must look for the origin of the "art preservative." Early in the tenth century, five hundred years before Gutenberg contrived moveable metal types which have rendered his name imperishable, an imperial edition of the sacred books was published in that far oriental country. But on the same principle the glory of America's discovery is given to Columbus and not to Lief Ericson. He was

PRACTICAL AIDS TO FINE TYPOGRAPHICAL EFFECTS

12345 Man, it Has Been Said is a Bundle of Earthly Habits 67890

8-POINT FRENCH OLD STYLE.

THE first thing to be considered in the formation of a model composing room is the room itself. Many workrooms, at the present time, are unfit for the habitation of human beings. They are pestilential abodes, where lurk the germs of many of the diseases humanity are subject to. How can a place be healthy, permeated with the deadly fumes arising from a floor filthy with dirt and thickly coated with an accumulation of tobacco spittle, with here and there an old "soldier," which perhaps has remained undisturbed for years? How can a room be perfectly healthy, which is never thoroughly ventilated, and where the atmosphere is at all times stifling and oppressive? "Cleanliness is next to godliness," and in the composing room the exemplification to this fact is as apparent as anywhere. It imparts a degree of comfort which is invigorating. It imbues us with a sense of cheerfulness which seems to lessen the effect of toil. So, in my idea of a model composing room the first essential is cleanliness, for where that abounds

QUAINT RHYMES WITH GRAND PICTURES

12345 abcdefghijklmnopqrstuvwxyz 67890

Lower case a to z 13 3/4 ems.

ABCDEFGHIJKLMNPOQRSTUVWXYZÆOE&

The first thing to be considered in the formation of a model composing room is the room itself. Many workrooms, at the present time, are unfit for habitation of human beings. They are pestilential abodes, where lurk the germs of many of the

PRACTICAL AIDS TO FINE TYPOGRAPHY

12345 Now Man is a Bundle of Earthly Habits 67890

FRENCH OLD STYLE

10-POINT FRENCH OLD STYLE.

OF the perplexities of the composing room, and they are numerous, those relating to punctuation are by no means the least. Watch the perspiring compositor wrestling with an involved sentence, and note the changing expression of his countenance as the emotions of inquiry, doubt, certainty, and again doubt followed by despair, flit through his mind, and then the final decision to seek the "brainery," or, with the muttered "shibboleth," as Byron calls it, recklessly plugging away, trusting that it might be right, or, feeling that the proofreader will mark it differently on principle, it is losing time for him to study over the matter longer. If he seeks advice or sympathy

THE NICKLESS QUADS ARE POPULAR

12345 abcdefghijklmnopqrstuvwxyz 67890

Lower case a to z 12¼ ems.

ABCDEFGHIJKLMNPOQRSTUVWXYZÆOE&

Of the perplexities of the composing room, and they are numerous, those relating to punctuation are by no means the least. Watch the perspiring compositor wrestling with an involved sentence, and note

PRACTICAL AIDS TO PRINTING

12345 *Man is a Bundle of Earthly Habits* 67890

12-POINT FRENCH OLD STYLE.

IN looking over early printed books, even in the most casual manner, the attention is at once attracted by the great profusion of abbreviations or contractions and the various spellings of not only ordinary words, but the names of persons and places as well. Indeed these last seem to have suffered the most, contractions being carried to such an extent in some instances as to well nigh defeat the object in printing the name. In the matter of abbreviations those early printers

INCREASING DEMANDS

123 abcdefghijklmnopqrstuvwxyz 485

Lower case a to z 12½ ems.

ABCDEFGHIJKLMNPOQRSTUVWXYZÆOE&

In looking over early printed books, even in the most casual manner, the attention is at once attracted by the great profusion of

NORTHERN LIGHTS SHINE

1234 *Inventions of Printing Tools* 5678

OLD STYLE No. 10

6-POINT OLD STYLE No. 10.

MANY are the devices resorted to by the modern printer to produce fine work, one of the principal of which, and used more frequently than any other during the past few years, is what is commonly known as "rule twisting." Designs both simple and intricate, some of them truly wonderful in their conception and execution, have been evolved from the fertile brain of the inventive compositor, and there seems to be an increasing demand for such work: in fact, some of the larger concerns keep a man whose whole time is spent in furnishing designs, and shaping rule for the finest work. Printers who have made artistic rule work a study, and furnished many useful and ornamental designs, have demonstrated beyond the shadow of a doubt the capabilities of brass rule in the hands of an ingenious and painstaking printer.

In dull seasons the artist-compositor can utilize spare moments in making new designs, and when work is rushing and a job comes in calling for something special, all he has to do is to select from among the number of designs on hand the one most suitable.

There never has been a time when so much assistance could be obtained, in the way of rule-working machinery, as at the present, which will enable a compositor, with little study and practice to become so proficient in the art of "rule twisting," that he may rise far above the ordinary compositor and bring to his employer and himself both renown and profit.

In this specimen book may be found an infinite variety of brass rules from which a printer may select, to produce almost any conceivable idea promulgated by the artist compositor in his realm of acute aspirations.

PRACTICAL AIDS TO FINE PRINTING

12345

abcdefghijklmnopqrstuvwxy

67890

Lower case a to z 1¼ ems.

ABCDEFGHIJKLMN O PQRSTU VWXYZÆ&

Many are the devices resorted to by the modern printer to produce fine work, one of the principal of which, and used more frequently than any other during the past few years, is what is commonly known as "rule twisting." Designs both simple and intricate, some of them truly wonderful in their conception and execution, have been evolved from the fertile brain of the inventive compositor, and there seems to be an increasing demand for such work: in fact, some of the larger concerns keep a

PRACTICAL AIDS TO ARTISTIC TYPOGRAPHY

12345

Gutenberg Printed the Bible and Other Books

67890

8-POINT OLD STYLE No. 10.

MANY are the devices resorted to by the modern printer to produce fine work, one of the principal of which, and used more frequently than any other during the past few years, is what is commonly known as "rule twisting." Designs both simple and intricate, some of them truly wonderful in their conception and execution, have been evolved from the fertile brain of the inventive compositor, and there seems to be an increasing demand for such work; in fact, some of the large concerns keep a man whose time is spent in furnishing designs, and shaping rules for the finest work. The printers who have made artistic rule work a study, and furnished many useful and ornamental designs have demonstrated beyond the shadow of a doubt the capabilities of brass rule in the hands of an ingeneous and painstaking printer.

In dull seasons the artist-compositor can utilize spare moments in making new designs, and when work is rushing and a job comes in calling for something special, all he has to do is to select from among the number of designs on hand the

PRACTICAL AIDS TO FINE PRINTING

12345

abcdefghijklmnopqrstuvwxy

67890

Lower case a to z 1¾ ems.

ABCDEFGHIJKLMN O PQRSTU VWXYZÆ&

Many are the devices resorted to by the modern printer to produce fine work one of the principal of which and used more frequently than any other during the past few years is what is commonly known as "rule twisting." Designs both simple and intricate, some of them truly wonderful in their concep-

PRACTICAL AIDS TO FINE PRINTING

12345

High School Boys Parading in Boston

67890

OLD STYLE No. 10

10-POINT OLD STYLE No. 10.

MANY are the devices resorted to by the modern printer to produce fine work, one of the principal of which, and used more frequently than any other during the past few years, is what is commonly known as "rule twisting." Designs both simple and intricate, some of them truly wonderful in their conception and execution, have been evolved from the fertile brain of the inventive compositor, and there seems to be an increasing demand for such work: in fact, some of the larger concerns keep a man whose whole time is spent in furnishing designs, and shaping rules for the finest work. The printers who have made artistic rule work a study,

PRACTICAL AIDS TO FINE PRINTING

12345 abcdefghijklmnopqrstuvwxyz 67890

Lower case a to z 12¼ ems.

ABCDEFGHIJKLMNPOQRSTUVWXYZÆ&&

Of the perplexities of the composing room, and they are numerous, those relating to punctuation are by no means the least. Watch the perspiring compositor wrestling with an involved sentence, and note how he

FLAWLESS LEADS AND SLUGS

1234 Metal Furniture and Quotations 5678

11-POINT OLD STYLE No. 10.

IN printing colors it frequently seems impossible to get the true value of the tint, no matter how carefully it may have been chosen. It can, however, be obtained by again passing the sheet after drying through the press. Printers' ink is a kind of paint, and it is generally applied to a white surface. There it forms a coating descending very little below the surface. No more can be placed there by the rollers when the work is new, because the surplus ink clings to them. Let it dry, and it will take another coating, just as a house will. The first coating is called the

PRACTICAL AIDS TO PRINTING

12345 abcdefghijklmnopqrstuvwxyz 67890

Lower case a to z 12 ems.

ABCDEFGHIJKLMNPOQRSTUVWXYZÆ&&

In printing colors it frequently seems impossible to get the true value of the tint, no matter how carefully it may have been chosen. It can, how-

MANAGING EDITORS PICNIC

1235 Greater Economy is Attainable 6890

OLD STYLE No. 10

12-POINT OLD STYLE No. 10.

MANY are the devices resorted to by the modern printer to produce fine work, one of the principal of which, and used more frequently than any other during the past few years, is what is commonly known as "rule twisting." Designs both simple and intricate, some of them truly wonderful in their conception and execution have been evolved from the fertile brain of the inventive compositor, and there seems to be an increasing demand for such work;

PRACTICAL PRINTING

1234 abcdefghijklmnopqrstuvwxyz 5678

Lower case a to z 12½ ems.

ABCDEFGHIJKLMN OPQRSTUVWXYZÆ&

Many are the devices resorted to by modern printers to produce fine work, one of the principal of which, and used more frequent

ORCHESTRAL MUSIC

12345 *Played by Great Masters* 67890

Sorts furnished at short notice.

18-POINT OLD STYLE No 10.

THE first processes resorted to in the practice of typography, cutting punches and the making of moulds, demanded a degree of skill in handling tools and of experience in the working of metal rarely found in any man who undertook to learn the art of printing. They were never regarded as proper branches of the printer's trade.

FINE PRINTING

abcdefghijklmnopqrstu vwxyz

Lower case a to z 11¼ ems.

123 NEATLY EXECUTED 456

Everything cast under one roof.

10-POINT OLD STYLE No. 11

OFFICE RUN SYSTEMATICALLY

A reputation for promptness is one of the things that a job printer should strive for. He will have gained a great advantage when it will be said of him that he always gets work out on time, and it will pay him to endeavor to secure such a reputation by every means in his power. I know how prone is the ordinary business man to wait until he is clean out of stationery, or any thing he wants, before ordering more, or to postpone until the last possible moment the order for circulars, or handbills, or any other bit of commercial work; and then, when he does give you the order, he acts as though he thought his was the only work you had in your shop, that you should immediately give him precedence over everybody else. If your office is run systematically, you can tell after a moment's reflection just how the work is getting on, and what chances there are for getting a new job started in. Then you can tell your customer when he can have his work, within an hour or two, unless it is a job of considerable magnitude. Then if he says that is too late, tell him you are sorry, but

6-POINT SPECIAL HANDY BRACES

Shown on page 167

Special Handy Braces are made to save the printer a lot of worry and bother looking for piece braces. In setting up matter where braces are called for, the Special Handy Braces will fit the type lines from 1-4 inch to one and one-half inch. They are made in seven sizes, are light face, and will not detract from the type used. When in need of the above, call at 190-192 Congress Street, Boston, and obtain a great Labor-saving font of SPECIAL BRACES, which are sold at \$1.25 per font.

abcdefghijklmnopqrstuvwxy

Lower case a to z 13 ems

12345 ABCDEFGHIJKLMNOPQRSTUVWXYZ 67890

CABINETS AND STANDS.

When in the course of human events it may become necessary for one People to dissolve the political bands which have connected them with

HANSEN'S INVENTIONS

OLD STYLE No. 12

6-POINT RONALDSON OLD STYLE No. 12.

MANY are the devices resorted to by the modern printer to produce fine work, one of the principal of which, and used more frequently than any other during the past few years, is what is commonly known as "rule twisting." Designs both simple and intricate, some of them truly wonderful in their conception and execution have been evolved from the fertile brain of the inventive compositor, and there seems to be an increasing demand for such work: in fact some of the large concerns keep a man whose whole time is spent in furnishing designs, and shaping rule for the finest work. All printers who have made artistic rule work a study, and furnished many useful and ornamental designs, have demonstrated beyond the shadow of a doubt the capabilities of brass rule in the hands of an ingenious and painstaking printer.

In dull seasons the artist-compositor can utilize spare moments in making new designs, and when work is rushing and a job comes in calling for something special, all he has to do is to select from among the number of designs on hand the one most suitable.

There never has been a time when so much assistance could be obtained, in the way of rule-working machinery, as at the present, which will enable a compositor, with little study and practice to become so proficient in the art of "rule-twisting," that he may rise far above the ordinary compositor and bring to his employer and himself both renown and profit.

FINE TYPOGRAPHICAL PRODUCTIONS MADE

12345 abcdefghijklmnopqrstuvwxyz 67890

Lower case a to z 17½ ems.

ABCDEFGHIJKLMNQPQRSTUVWXYZÆ&

A most complete selection of Brass Rule may be found in this Specimen Book, which will suit fastidious tastes and enrich embellishments which are the acme of modern typography. The infinite variety from which to choose enables a printer not only to match rule in almost any reprint job but to execute original ideas in rule work satisfactory to himself of intricate delimitations.

FINE TYPOGRAPHICAL PRODUCTIONS MADE

12345 *Man, it Has Been Said is a Bundle of Habits* 67890

8-POINT RONALDSON OLD STYLE No. 12.

MANY are the devices resorted to by the modern printer to produce fine work, one of the principal of which, and used more frequently than any other during the past few years, is what is commonly known as "rule twisting." Designs both simple and intricate, some of them truly wonderful in their conception and execution have been evolved from the fertile brain of the inventive compositor, and there seems to be an increasing demand for such work: in fact, some of the larger concerns keep a man whose whole time is spent in furnishing designs, and shaping rules for the finest work. The printers who have made artistic rule work a study, and furnished many useful and ornamental designs, have demonstrated beyond the shadow of a doubt the capabilities of brass rule in the hands of an ingenious and painstaking printer.

In dull seasons the artist-compositor can utilize spare moments in making new designs, and when the work is

PRACTICAL AIDS TO FINE PRINTING

12345 abcdefghijklmnopqrstuvwxyz 67890

Lower case a to z 14½ ems.

ABCDEFGHIJKLMNQPQRSTUVWXYZÆ&

A most complete selection of Brass Rule may be found in this Specimen Book, which will suit fastidious tastes and enrich embellishments which are the acme of modern typography. The infinite variety from which to choose

FINE TYPOGRAPHICAL PRODUCTION

12345 *Man is a Bundle of Earthly Habits* 67890

OLD STYLE No. 12

10-POINT RONALDSON OLD STYLE No. 12.

MANY are the devices resorted to by the modern printer to produce fine work, one of the principal of which, and used more frequently than any other during the past few years, is what is commonly known as "rule twisting." Designs both simple and intricate, some truly wonderful in their conception and execution, have been evolved from the fertile brain of the inventive compositor, and there seems to be an increasing demand for such work; in fact, the larger concerns keep a man whose whole time is spent in furnishing designs, and shaping rule for the finest work. Printers who have

PRACTICAL AIDS TO PRINTING

12345 abcdefghijklmnopqrstuvwxyz 67890

Lower case a to z 14 ems.

ABCDEFGHIJKLMN OPQRSTUVWXYZ&

Many are the devices resorted to by the modern printer to produce fine work, one of the principal of which, and used more frequently than any other during the past few years, is what is commonly

ITALICS FOR ROMAN FONTS

12345 *Fine Typographical Productions* 67890

11-POINT RONALDSON OLD STYLE No. 12.

MANY are the devices resorted to by the modern printer to produce fine work, one of the principal of which, and used more frequently than any other during the past few years, is what is commonly known as "rule-twisting." Designs both simple and intricate, some of them truly wonderful in their conception and execution, have been evolved from the fertile brain of the inventive compositor, and there seems to be an increased demand for such work; in fact some of the larger concerns keep a man whose whole

PRACTICAL AIDS TO PRINTING

1234 abcdefghijklmnopqrstuvwxyz 5678

Lower case a to z 13 $\frac{1}{4}$ ems.

ABCDEFGHIJKLMN OPQRSTUVWXYZ&

Many are the devices resorted to by the modern printer to produce fine work; one of the principal of which, and used more than

ENGLISH MEN ARE MERRY

1234 *Sailing on the British Channel* 5678

OLD STYLE No. 12

12-POINT RONALDSON OLD STYLE No. 12.

MANY are the devices resorted to by the modern printer to produce fine work, one of the principal of which, and used more frequently than any other during the past few years, is what is known as "rule twisting." Designs both simple and intricate, some of them truly wonderful in their conception and execution have been evolved from the fertile brain of the inventive compositor, and there seems to be an increasing demand for such work; in fact some of the large

GOATS HORNS SCRAPED

123 abcdefghijklmnopqrstuvwxyz 456

Lower case a to z 13½ ems.

ABCDEFGHIJKLMN OPQRSTUVWXYZ&

Many are the devices resorted to by the modern printer to produce fine work, one of the principal of which, and used more

ENTHUSIASTIC SINGERS

1234 *Singing Christmas Carols* 5678

18-POINT RONALDSON OLD STYLE No. 12.

Many are the devices used by modern printers to produce fine work, one of the principal of which, and used more frequently than any other during the past few years, is what is commonly known as "rule-twisting." Designs both simple and intricate, some truly wonderful in their conception and execution, have evolved from the fertile brain of the

abcdefghijklmnopqrstu vwxyz

Lower case a to z 12 ems.

123 FINE PRINTING 456

MODERN AND OLD STYLE JOB FONTS.

100 a 40 A 20 A 6-PT. RONALDSON OLD STYLE No. 12. \$3.60

MANY are the devices resorted to by the modern printer to produce fine work, one of the principal of which, and used more frequently than any other during the past few years, is what is commonly known as "rule twisting." Designs both simple and

PRACTICAL AIDS TO FINE PRINTING

12345 RULE CURVING AND SHAPING MACHINES 67890

90 a 40 A 20 A 8-PT. RONALDSON OLD STYLE No. 12. \$4.17

MANY are the devices resorted to by modern printers to produce fine work, one of the principal of which, and used more frequently than any other during the past

DECLARATION OF AMERICAN INDEPENDENCE

123 CAPTURED FOUR IRONCLAD FRIGATES 457

80 a 40 A 20 A 10-PT. RONALDSON OLD STYLE No. 12. \$4.81

MANY are the devices resorted to by modern printers to produce fine work, one of the principal of which, and used more frequently than

PRACTICAL AIDS TO FINE PRINTING

1234 FINE PRESS AND CABINET 6789

62 a 28 A 16 A 12-PT. RONALDSON OLD STYLE No. 12. \$5.21

MANY are the devices resorted to by modern printers to produce fine work, one of the principal of which, and used

PRACTICAL AIDS TO PRINTING

123 PRINTERS' FURNITURE 456

32 a 12 A 8 A 18-PT. OLD STYLE No. 10. \$4.70

THE first processes in the practice of typography were
FINE PRINTING

34 ORNAMENTS AND BORDERS 56

32 a 12 A 18-PT. RONALDSON OLD STYLE No. 12. \$4.05

THE first processes in the practice of typography were
FINE PRINTING

12 Executed by Artists 34

15 a 8 A 4 A 24 PT ROMAN No. 4. \$4.80

PRINTING was first
practiced in the new
NORTHERN
45 GRAND BALL 78

CASLON OLD STYLE

25 pounds and over

6-Point.

Roman rates.

HOW SHALL I BECOME A WRITER OF ADS.?

Keep on writing ads. The way how to learn to swim is to swim; the way to get experience is to keep on swimming. One can tell at once when a beginner becomes an adept swimmer or ad-writer, any more than he can tell when a kitten becomes a cat. In ad-writing, as in swimming, rules dont help much; the main thing is to keep on working. If you go ahead persistently, getting all the training and experience you can, writing ads, and getting people to use them on any terms, or on no terms at all, you will certainly write better and better ads,—unless you have mistaken your calling. As you go on keep comparing your latest ads. with previous ones, and see whether you improve, and compare those ads with previous ones, and see whether you improve; and compare those ads, which are accepted and used with those which are declined, and try to see what it is that makes people think them good or poor. Keep always in mind that the first thing an ad-writer must do is to suit the advertiser, then to get results. When your ads are used try to find out what the results are, and compare those that "pull" with those that don't. If you can get up three or four ads that somebody will use, and that "pull" when he does use them, you probably won't have much difficulty with that advertiser afterward. The danger will be that he may then place more reliance on your ability than it deserves, and that you may get "swelled head," and stop improving. After you have got a fair training, and some experience, and one or two people have come to use your ads., and perhaps to pay something for them, you will probably have a position of some kind offered you,—it may be a salesman, clerk, or stock keeper, in addition to writing ads. and show cards. dressing show-windows, etc.; or it may be as assistant in the advertising department of a large business. Such a position often gives one most valuable experience, and is likely also to lead to rapid advancement; for the demand for practical men and women, who can write good advertisements and do something else too, is very great. The young ad-writer ought, however, to guard against getting into a rut, and becoming narrow. There is hardly another profession in which varied experience is so necessary; and a person who gets a comfortable position as ad-writer for one store needs to take care that he does not stop growing, and

12345

abcdefghijklmnopqrstuvwxyz

67890

Lower case a to z 13¼ ems

PRINTING FURNITURE FOR GOOD WORK

1872 Type faces made to order. Figures, Rules, Leads, Slugs etc. 1003

LEADING FURNITURE FOR YOUR OFFICE AT

H. C. HANSEN'S, CONGRESS STREET, BOSTON, MASS.

25 pounds and over

8-Point.

Roman rates.

YOU CANNOT GET TOO MUCH EXPERIENCE

Become narrow, dull, self-satisfied and careless, and end by losing the one position that he holds. You cant get too much experience; and that means that writing for two businesses is far better than writing for one. A man who can write good hardware ads., where there is a succession of new contrivances, but who "falls down" on staples like coal or clothing, needs a wider and more varied field. If he gives up his position as salesman in the hardware store, and takes half the salary for writing ads. only, and then make a similar engagement with a clothing-house and a coal dealer, all of his ads. will be better, he will get a far more valuable experience, and he will make more money. That is, always provided he is really born to be an ad-writer. A born ad-writer is one who would rather write ads. at twenty dollars a week than do anything else at twenty-five. If he would rather have a "soft snap" at twenty-five, doing the ad-writing to hold the position, then this article is not addressed to him. The persons I have in mind are those who have their eyes on the heights of the profession, who will regard a twenty dollar position mainly as a chance to get experience that will qualify them for a fifty dollar position, and a fifty dollar position to a stepping stone as to a business that will pay five or ten thousand dollars a year. Now to qualify one for such a career, the great need is to keep growing. Good ad-writing means finding out the points about goods that will make people buy them. If you confine and acquire yourself to a narrow range of goods, you will almost certainly yourself grow narrow, shrink, and "dry

12345

abcdefghijklmnopqrstuvwxyz

67890

Lower case a to z 10¼ ems

*Place your order for a Mitering Machine**All orders filled at once. All type, etc. made under one roof at**Hansen's, the complete printing office furnisher*

123

Tons and tons of type for printer's immediate use

456

CASLON OLD STYLE

25 pounds and over

10-Point

Roman Rates

THE FULL ADVANTAGE THAT may be realized from the use of time slips is not secured if they are simply utilized for calculations as to the cost of the work being done, and are not availed of as a valuable help in finding the relative values of your different workmen. If the time is kept accurately, and two or more men are employed on the same work under conditions which are identical, then it becomes an easy matter to arrive at valuable conclusions which should have a direct bearing on the pay-roll. If time reports are not kept accurately, and are only tolerated by the workmen as a necessary evil, and if the time is not reported in such way that the account can be balanced, then the system is almost valueless, and any system is almost valueless and any system that is followed up in a half hearted way might as well be abandoned, as its effect on shop discipline can not be other than pernicious. When workmen realize

abcdefghijklmnopqrstuvwxyz

Lower case a to z 10¼ ems.

Many are the devices resorted to by the modern printers to produce fine work, one of the principal of which, and used more frequently than any other during the past, and
 12345 TYPE, LEADS, ETC., ETC. 67890

25 pounds and over

12-Point

Roman Rates

THE FULL ADVANTAGE THAT may be realized from the use of time slips is not secured if they are simply utilized for calculations as to the cost of work being done, and are not availed of as a valuable help in finding the relative values of your different workmen. If the time is kept accurately, and two or more men are employed on the same work under conditions which are identical, it becomes an easy matter to arrive at conclusions which should have a direct bearing on the pay-roll. If time reports are not kept,

abcdefghijklmnopqrstuvwxyz

Lower case a to z 11¼ ems

Many are the devices resorted to by the modern printer to produce fine work, one of the principal of which, and used more frequently than

ITALICS FOR CASLON FONTS

CASLON OLD STYLE JOB FONTS.

25A 70a 6-Point Caslon Old Style \$2.00

THE FULL ADVANTAGE DERIVED FROM TIME SLIPS is not secured if they are simply utilized for calculations as to the cost of the work being done, and are not availed of as a valuable slip for all

H. C. HANSEN, TYPE FOUNDER, BOSTON

All Type, Leads, Slugs, etc. manufactured in this Type Foundry are made of the best material and gives the best satisfaction to purchasers. Use Hansen's material. It has no equal. Give it a fair trial and you will use no other make

20A 60a 8-Point Caslon Old Style \$2.25

TYPE, BORDERS, LEADS, SLUGS, FURNITURE

All manufactured in this Type Foundry, 190-192 Congress Street, and all orders shipped on short notice. All orders receive prompt attention.

BRASS RULES MADE TO ORDER

Modern type for all styles in the printing line can be purchased from H. C. Hansen, where complete printing offices are furnished at short notice. When you are intending to purchase call at the above address

18A 56a 10-Point Caslon Old Style \$2.50

WE MANUFACTURE EVERYTHING

See the expansion of the H. C. Hansen Type Foundry in producing and turning out material for printers use in short order, and in accurate time. The quality is the best made in a type foundry, and H. C. Hansen makes the best. 123 Look for the manufactures from Hansen's Type Foundry.

MITERING MACHINES, LEAD CUTTERS,
CURVING MACHINES, ETC.

16A 46a 12-Point Caslon Old Style \$2.75

HANSEN'S MANUFACTURES have no equal. Manufactured at his large and commodious quarters, where customers are treated with Promptness and Despatch
**COMPLETE MITERING MACHINE
EIGHTEEN DOLLARS**

14A 40a 14-Point Caslon Old Style \$3.00

MANY NEW TYPE FACES shown in this specimen book, also brass rules designed by H. C. Hansen, Type Founder, 190-192 Congress Street
BOSTON, MASS.

12A 22a 16-Point Caslon Old Style \$3.25

NO ORDER TOO LARGE
none too small to be served from this Type Foundry. All orders handled carefully
Quality, Accuracy & Promptness

Small Caps put up in separate fonts.

CASLON OLD STYLE ITALIC JOB FONTS

18A 55a 6-Point Caslon Old Style Italic \$2.00

*NEWSPAPER, BOOK AND JOB TYPE
DISPLAY TYPE FOR ADVERTISEMENTS, MAGAZINES, ETC.
See Specimen Book for the various styles of type for all kinds of work that is done
in a printing office, manufactured and for sale by H. C. Hansen,
BOSTON, MASS*

18A 56a 8-Point Caslon Old Style Italic \$2.25

*LOWEST PRICES AND BEST GOODS
are handled by H. C. Hansen, Type Founder, 190-192 Congress St.,
where customers are treated courteously and with despatch
CALL AND BE CONVINCED OF THE ABOVE
EVERYTHING FOR A FIRST-CLASS PRINTING OFFICE*

16A 50a 10-Point Caslon Old Style Italic \$2.50

*LARGE AND COMMODIOUS BUILDING
situated in the centre of Boston's business district, and easy
to find when intending to purchase Type, Leads, & Slugs
ALL MANUFACTURED AT
H. C. HANSEN'S TYPE FOUNDRY, CITY*

14A 42a 12-Point Caslon Old Style Italic \$2.75

*COMPLETE MITERING MACHINE
Meters all angles accurately and saves printers
time and money. Set by a mere pin with no
lines to guess at
PRICE, EIGHTEEN DOLLARS*

12A 36a 14-Point Caslon Old Style Italic \$3.00

*MODERN IMPROVEMENTS
Always ready to fill the largest orders on
the shortest possible notice
New dresses for Newspaper Offices, Etc.
AT 190-192 CONGRESS STREET.*

9A 25a 16-Point Caslon Old Style Italic \$3.25

*COLTS ARMORY PRESS
with a Cylinder Distribution for
embossing and printing. The best
and strongest Platen Press made
CALL AND SEE IT
at the
complete printing office furnisher,
and be supplied with everything at
short notice*

ROMAN No. 4

6-POINT ROMAN No. 4.

MANY are the devices resorted to by the modern printer to produce fine work, one of the principal of which, and used more frequently than any other during the past few years, is what is commonly known as "rule-twisting." Designs both simple and intricate, some of them truly wonderful in their conception and execution, have been evolved from the fertile brain of the inventive compositor, and there seems to be an increasing demand for such work; in fact, some of the larger concerns keep a man whose whole time is spent in furnishing designs, and shaping rule for the finest work. Printers who have made artistic rule work a study, and furnished many useful and ornamental designs, have demonstrated beyond the shadow of a doubt the capabilities of brass rule in the hands of an ingenious and painstaking printer. In dull seasons the artist-compositor can utilize spare moments in making new designs, and when work is rushing and a job comes in calling for something special, all he has to do is to select from among the number of designs on hand the one most suitable.

There never has been a time when so much assistance could be obtained, in the way of rule-working machinery, as at the present, which will enable a compositor, with little study and practice, to become so proficient in the art of "rule twisting," that he may rise far above the ordinary compositor and bring to his employer and himself both renown and profit.

PRACTICAL AIDS TO FINE PRINTING

12345 abcdefghijklmnopqrstuvwxyz 67890

Lower case a to z 16½ ems.

ABCDEFGHIJKLMN O PQRSTU VWXYZÆ&

Many are the devices resorted to by the modern printer to produce fine work, one of the principal of which, and used more frequently than any other during the past few years, is what is commonly known as "rule-twisting." Designs both simple and intricate, some of them truly wonderful in their conception and execution, have been evolved from the fertile

A FAINT HEART NEVER WON A FAIR WOMAN

12345 Man, it Has Been Said is a Bundle of Habits 67890

7-POINT ROMAN No. 4.

MANY are the devices resorted to by the modern printer to produce fine work, one of the principal of which, and used more frequently than any other during the past few years, is what is commonly known as "rule-twisting." Designs both simple and intricate, some of them truly wonderful in their conception and execution, have been evolved from the fertile brain of the inventive compositor, and there seems to be an increasing demand for such work; in fact, some of the larger concerns keep a man whose whole time is spent in furnishing designs, and shaping rule for the finest work. Printers who have made artistic rule work a study, and furnished many useful and ornamental designs, have demonstrated beyond the shadow of a doubt the capabilities of brass rule in the hands of an ingenious and painstaking printer.

In dull seasons the artist-compositor can utilize his spare moments in making new designs, and when work is rushing and a job comes in calling for something special, all he has to do is to select from among the number of designs on hand the one most suitable.

PRACTICAL AIDS TO FINE PRINTING

12345 abcdefghijklmnopqrstuvwxyz 67890

Lower case a to z 15½ ems

ABCDEFGHIJKLMN O PQRSTU VWXYZÆ&

Many are the devices resorted to by the modern printer to produce fine work; one of the principal of which, and used more frequently than any other during the past few years, is what is commonly known as "rule-twisting." Designs both simple and intricate, some of them truly wonderful in their conception and execution, have been evolved

PRACTICAL AIDS TO FINE PRINTING

ROMAN No. 3 and 4

8-POINT ROMAN No. 4.

MANY are the devices resorted to by the modern printer to produce fine work, one of the principal of which, and used more frequently than any other during the past few years, is what is commonly known as "rule twisting." Designs both simple and intricate, some of them truly wonderful in their conception and execution, have been evolved from the fertile brain of the inventive compositor, and there seems to be an increasing demand for such work; in fact, some of the larger concerns keep a man whose whole time is spent in furnishing designs, and shaping rule for the finest work. Printers who have made artistic rule work a study, and furnished many useful and ornamental designs have demonstrated beyond the shadow of a doubt, the capabilities of brass rule in the hands of an ingenious and painstaking printer. In dull seasons the artist-compositor can utilize spare moments in

PRACTICAL AIDS TO FINE PRINTING

12345 abcdefghijklmnopqrstuvwxyz 67890

Lower case a to z 14½ ems.

ABCDEFGHIJKLMNPOQRSTUVWXYZÆ&

Many are the devices resorted to by the modern printer to produce fine work, one of the principal of which, and used more frequently than any other during the past few years, is what is commonly known as "rule-twisting."

FINE TYPOGRAPHICAL PRODUCTIONS

12345 Neatly Executed by Artist Printers 67890

8-POINT ROMAN No. 3.

MANY are the devices resorted to by the modern printer to produce fine work, one of the principal of which, and used more frequently than any other during the past few years, is what is commonly known as "rule twisting." Designs both simple and intricate, some of them truly wonderful in their conception and execution, have been evolved from the fertile brain of the inventive compositor, and there seems to be an increasing demand for such work; in fact, some of the larger concerns keep a man whose whole time is spent in furnishing designs, and shaping rule for the finest work. Printers, who have made artistic rule work a study, and furnished many useful and ornamental designs, have demonstrated beyond the shadow of a doubt the capabilities of brass rule in the hands of an ingenious and painstaking printer. In dull seasons the artist-compositor can utilize spare moments in making new designs, and when work is rushing and a job comes

PRACTICAL AIDS TO FINE PRINTING

12345 abcdefghijklmnopqrstuvwxyz 67890

Lower case a to z 13½ ems.

ABCDEFGHIJKLMNPOQRSTUVWXYZÆ&

A most complete selection of Brass Rule may be found in this Specimen Book, which will suit fastidious tastes and enrich embellishments which are the acme of modern typography. The infinite variety from which to choose a

MODERN IMPROVEMENTS IN PRESSES

12345 Rotary Power Improved Perforators 67890

ROMAN No. 2 and No. 4

10-POINT ROMAN No. 4.

MANY are the devices resorted to by modern printers to produce fine work, one of the principal of which, and used more frequently than any other during the past few years, is what is commonly known as "rule twisting." Designs both simple and intricate, some of them truly wonderful in their conception and execution, have been evolved from the fertile brain of the inventive compositor, and there seems to be an increasing demand for such work; in fact some of the larger concerns keep a man whose whole time is spent in furnishing designs, and shaping rule for the finest work. The printers who have made artistic rule work a study, and furnished many useful and ornamental designs

PRACTICAL AIDS TO PRINTING

12345 abcdefghijklmnopqrstuvwxyz 67890

Lower case a to z 12 $\frac{1}{2}$ ems.

ABCDEFGHIJKLMNOPQRSTUVWXYZÆ&

Many are the devices resorted to by the modern printer to produce fine work, one of the principal of which, and used more frequently than any other during the past few years, is what is com-

PRACTICAL TYPOGRAPHY

12345 Black or Colored Printing Ink 67890

10-POINT ROMAN No. 2.

MANY are the devices resorted to by the modern printer to produce fine work, one of the principal of which, and used more frequently than any other during the past few years, is what is commonly known as "rule twisting." Designs both simple and intricate, some of them truly wonderful in their conception and execution, have been evolved from the fertile brain of the inventive compositor, and there seems to be an increasing demand for such work; in fact, some of the larger concerns keep a man whose whole time is spent in furnishing designs, and shaping rule for the finest work. Printers who have made artistic rule work a study, and furnished many useful and ornamental designs, have demonstrated beyond the shadow of doubt

PRACTICAL AIDS TO FINE PRINTING

12345 abcdefghijklmnopqrstuvwxyz 67890

Lower case a to z 11 $\frac{1}{4}$ ems.

ABCDEFGHIJKLMNOPQRSTUVWXYZÆ&

Printing was first practiced in the New World in the city of Mexico, by Juan Cromberger, or his agent Pablos, between 1536 and 1540. The discovery of Mexican books by which the date is

HISTORY OF ART PRINTING

12345 Gutenberg and Faust Company 67890

ROMAN No. 4 and No. 8

11-POINT ROMAN No. 8.

MANY are the devices resorted to by the modern printer to produce fine work, one of the principal of which, and used more frequently than any other, during the past few years, is what is commonly known as "rule twisting." Designs both simple and intricate, some of them truly wonderful in their conception and execution, have been evolved from the fertile brain of the inventive compositor, and there seems to be an increasing demand for such work; in fact, some of the larger concerns keep a man

PRACTICAL AIDS TO PRINTING

12345 abcdefghijklmnopqrstuvwxyz 67890

Lower case a to z 13¼ ems.

ABCDEFGHIJKLMN O PQRSTU VWXYZÆ&

To China, the birthplace of so many of the useful arts and inventions, we must look for the origin of the "art preservative." Early in the tenth century, five hundred and

ANCIENT HISTORY QUOTED

1234 *First Introduction of Printing* 5678

12-POINT ROMAN No. 4.

MANY are the devices resorted to by the modern printer to produce fine work, one of the principal of which, and used more frequently than any other during the past few years, is what is commonly known as "rule-twisting." Designs both simple and intricate, some of them truly wonderful in their conception and execution, have been evolved from the fertile brain of the inventive compositor, and there seems to be an increasing demand for such work; in

PRACTICAL AIDS TO PRINTING

234 abcdefghijklmnopqrstuvwxyz 789

Lower case a to z 12¾ ems.

ABCDEFGHIJKLMN O PQRSTU VWXYZÆ&

Many are the devices resorted to by the modern printer to produce fine work, one of the principal of which, and used more frequently than any other during the past few

DEVELOP YOUR MUSCLES

1234 *Interest Bearing Certificate* 6789

ROMAN No. 4.

24-POINT ROMAN No. 4.

THE first processes used in the practice of typography were cutting punches and making moulds. It required great skill in the manipulation of tools and experience in the mixing

PRINTERS

Lower case a to z 13½ ems.

12 FINE ARTISTS 34

10-POINT MAILING TYPE.

Cast on 10-Point or Long Primer size, and put up in fonts carefully proportioned for Subscription Lists. A font contains Roman for names; Gothic for abbreviations, cast on em and en bodies; Figures on en body, and Clarendon for Post Office addresses, &c. Sorts furnished at short notice. A list of 1000 names will require about 100 lbs. of Long Primer or 10-Point Mailing Type. For Mailing Gallies see page 206.

BOSTON

Miss Kate Gohmme 30 May 96

Rev. S H Stone Box 2 26 Dec 93

Dr H Golden 24 Jan 82

Geo Tolstrup 30 Feb 87

Gen S Perry 23 Mar 89

Mrs G D Hopper 26 Apr 95

MALDEN

E May Snow 20 5 89

H Blue jeans 27 8 84

W m Early 30 5 96

Jas A King 24 5 95

F N Haddon 26 5 84

H Shannon 30 7 85

CHELSEA

Clara Johnson 20 July 94

C A Money 14 Sep 93

W m Coughlin 29 Oct 96

Gus Johnson 25 Nov 96

Geo Moller 16 Aug 87

John Williams 30 June 98

READING

W E Russell 23 5 94

T H Newton 30 8 86

Robt L Morse 26 5 78

M E Grover 23 5 84

S T White 30 8 75

W P Parsons 29 8 79

MODERN AND OLD STYLE JOB FONTS.

60 a 12 A 8 A 6-POINT ROMAN No. 4. \$2.25

WHEN, in the course of Human Events, it becomes necessary for one People to dissolve the political bands which have connected them with another, and to assume among the Powers of the Earth the separate and equal station to which the Laws of Nature and

RED COATS BREAKFASTED AT BUNKER HILL

12345 FINE TEA THROWN OVERBOARD IN BOSTON 67890

60 a 12 A 8 A 8-POINT ROMAN No. 4. \$2.50

WHEN, in the course of Human Events, it becomes necessary for one People to dissolve the political bands which have connected them with another, and assume

DECLARATION OF AMERICAN INDEPENDENCE

1234 CAPTURED MANY IRONCLAD FRIGATES 5678

60 a 12 A 8 A 10-POINT ROMAN No. 4. \$2.50

WHEN, in the course of Human Events, it becomes necessary for one People to dissolve the political bands which have connected them with

DECLARATION OF INDEPENDENCE

234 CAPTURED IRONCLAD FRIGATE 567

60 a 12 A 8 A 12-POINT ROMAN No. 4. \$3.50

WHEN, in the course of Human Events, it becomes necessary for one People to dissolve the political bands which have con-

BRITISH GUNBOAT CANNONS

234 PERFORATING MACHINES 567

100 a 40 A 20 A 6-POINT OLD STYLE No. 10. \$3.60

WHEN, in the course of Human Events, it becomes necessary for one People to dissolve the political bands which have connected them with another, and to assume among the Powers of the Earth the separate and equal station to which the Laws of Nature and of Nature's God entitle

RED COATS BREAKFASTED AT BUNKER HILL

12345 FINE TEA THROWN OVERBOARD IN BOSTON 67890

90 a 40 A 20 A 8-POINT OLD STYLE No. 10. \$4.17

WHEN, in the course of Human Events, it becomes necessary for one People to dissolve the political bands which have connected them with another, and to assume among

DECLARATION OF AMERICAN INDEPENDENCE

123 CAPTURED FOUR IRONCLAD FRIGATES 456

90 a 40 A 20 A 10-POINT OLD STYLE No. 10. \$4.81

WHEN, in the course of Human Events, it becomes necessary for one People to dissolve the political bands which have connected them with

DECLARATION OF INDEPENDENCE

123 CAPTURED IRONCLAD FRIGATES 456

62 a 28 A 16 A 12-POINT OLD STYLE No. 10. \$5.21

WHEN, in the course of Human Events, it becomes necessary for one People to dissolve the political bands which have a

DANISH GUNBOAT CANNONS

123 PERFORATING MACHINE 456

ITALIC JOB FONTS.

50 a 20 A 6-POINT No. 4 ITALIC. \$2.10

When, in the course of Human Events, it becomes necessary for one People to dissolve the bands which have connected them with another, and to assume among the Powers of the Earth the separate and equal station to which the Laws of Nature

*DECLARATION OF AMERICAN INDEPENDENCE*12345 *We will be Happy when Summer Comes Again* 67890

40 a 18 A 8-POINT No. 4 ITALIC. \$2.25

When, in the course of Human Events, it becomes necessary for one People to dissolve the political bands which have connected them with another, and to assume among

*DECLARATION OF INDEPENDENCE*12345 *Bicycle Exercise is Very Invigorating* 67890

40 a 16 A 10-POINT No. 4 ITALIC. \$2.55

When, in the course of Human Events, it becomes necessary for one People to dissolve the political bands which have connected them with

*INDIAN WARRIORS DANCING*1234 *Scalps Removed while You Wait* 5678

30 a 14 A 12-POINT No. 4 ITALIC. \$2.40

When, in the course of Human Events, it becomes necessary for one People to dissolve the political bands which have been

*GLORIOUS INDEPENDENCE*12345 *Our Honorable Citizens* 67890

50 a 20 A 6-POINT OLD STYLE No. 10 ITALIC. \$2.00

When, in the course of Human Events, it becomes necessary for one People to dissolve the political bands which have connected them with another, and to assume among the Powers of the Earth the separate and equal station to which the Laws of Nature and of Nature's God entitle

*GRAND FIREWORKS DISPLAY IN JULY*12345 *Celebrated Every Year at the Beaches by Fireworks* 67890

40 a 18 A 8-POINT OLD STYLE No. 10 ITALIC. \$2.20

When, in the course of Human Events, it becomes necessary for one People to dissolve the political bands which have connected them with another, and to assume among the Powers of

*ANCIENT ARTILLERY COMPANY*12345 *Visiting London, Naples, and Paris* 67890

40 a 16 A 10-POINT OLD STYLE No. 10 ITALIC. \$2.25

When, in the course of Human Events, it becomes necessary for one People to dissolve the political bands which have connected them with another, and assume

*INVENTORS IN AMERICA*12345 *Eastertide Rides to the Lakes* 67890

30 a 14 A 12-POINT OLD STYLE No. 10 ITALIC. \$2.75

When, in the course of Human Events, it becomes necessary for one People to dissolve the political bands which have been connected

*BEAUTIFUL FOUNTAIN*12345 *Little Dew Drops Glitter* 67890

ITALIC JOB FONTS.

50a 20 A 6-POINT OLD STYLE NO. 12 ITALIC \$2.10

When, in the course of Human Events, it becomes necessary for our People to dissolve the political bands which have connected them with another, and to assume among the Powers of the Earth the separate and equal station to which the Laws of Nature and of Nature's God

CATHODE RAYS PENETRATING HUMANITY

12345 *Infinite Assistance Unknown to Surgical Science* 67890

40 a 18 A 8-POINT OLD STYLE NO. 12 ITALIC. \$2.15

When, in the course of Human Events, it becomes necessary for one People to dissolve the political bands which have connected them with another, and to assume

JINGOISM MEETED TO IGNORANCE

12345 *War Talk is the Path to Presidency* 67890

40 a 16 A 10-POINT OLD STYLE NO. 12 ITALIC. \$2.25

When, in the course of Human Events, it becomes necessary for one People to dissolve the political bands which have connected them with another

BLOW YOUR HORN LOUDEST

12345 *And the Populace will Follow You* 67890

30 a 14 A 12-POINT OLD STYLE NO. 12 ITALIC. \$2.50

When, in the course of Human Events, it becomes necessary for one People to dissolve the political bands which have bound

GREAT IN SMALL THINGS

12345 *Believe Half you are Told* 67890

45 a 20 A 6-POINT FRENCH OLD STYLE ITALIC. \$2.25

When, in the course of Human Events, it becomes necessary for one People to dissolve the political bands which have connected them with another, and to assume among the Powers of the Earth the separate and equal station to which the Laws of Nature and of Nature's God entitle

DECLARATION OF AMERICAN INDEPENDENCE

12345 *United States Commissioners of Internal Revenue* 6790

60 a 24 A 8-POINT FRENCH OLD STYLE ITALIC. \$2.75

When, in the course of Human Events, it becomes necessary for one People to dissolve the political bands which have connected them with another, and to assume among the Powers of

DECLARATION OF INDEPENDENCE

1234 *Anticipating Serious Results from Squandering* 579

50 a 20 A 10-POINT FRENCH OLD STYLE ITALIC. \$3.00

When, in the course of Human Events, it becomes necessary for one People to dissolve the political bands which have connected them with another, and assume

IMPORTANT POLAR DISCOVERY

12345 *Rays Penetrating the Human Body* 67890

40 a 16 A 12-POINT FRENCH OLD STYLE ITALIC. \$3.50

When, in the course of Human Events, it becomes necessary for one People to dissolve the political bands which have been a

HOUSE OF COMMONS

123 *Grandest Display of the Century* 645

VIKING

25 pounds and over

6-POINT

Roman Rates

HINTS THAT ARE WORTH LOOKING OVER

A reputation for promptness is one of the things that a job printer should strive for. He will have gained a great advantage when it comes to be said of him that he always gets work out on time, and it will pay him to endeavor to secure such a reputation by every means in his power. I know how prone is the ordinary business man to wait until he is clean out of stationery, or whatever he wants, before ordering more, or to postpone until the latest possible moment the order for circulars, or handbills or any bit of commercial work; and then, when he does give you the order, he acts as though he thought his was the only work you had in your shop—that you should immediately give him precedence over everybody else.

If your office is run systematically, you can tell after a moment's reflection just how the work is getting on, and what chances there are for getting a new job started in. Then you can tell your customer when he can have his work, within an hour or two, unless it is a job of considerable magnitude. Then if he says that is too late, tell him you are sorry, but you would rather lose the order than disappoint him in the delivery of it. Explain the situation fully to him, and it is ten chances to one he will leave the order.

If he does so, you must have that work ready when it is promised. One failure to keep your word in this respect will do you incalculable harm. Don't promise it a minute earlier than you have it ready, but never let the appointed hour go by without delivering the work.

So much for building up reputation. You will have to help spread that reputation yourself by telling about it in your advertising. The adoption of a "catch line" or "trade motto" is just as good for a printer's advertising as for that of any other man. "Ready when you want it," or "If it isn't done, when promised, don't take it," or "Done on time, and done right." Such a phrase, if adopted, should be used on every piece of advertising the office uses, and in time—and a short time too—it will come to be recognized as characteristic of the establishment.

With promptness and punctuality as themes, it ought to be easy for any man who is bright enough to be a good printer, to write good advertising for a printery.

25 pounds and over

8-POINT

Roman Rates

DOES YOUR BUSINESS INCREASE ?

A reputation for promptness is one of the things that a job printer should strive for. He will have gained a great advantage when it comes to be said of him that he always gets work out on time, and it will pay him to endeavor to secure such a reputation by every means in his power. I know how prone is the ordinary business man to wait until he is clean out of stationery, or whatever he wants, before ordering more, or to postpone until the latest possible moment the order for circulars, or handbills, or any other bit of commercial work; and then, when he does give you the order, he acts as though he thought his was the only work you had in your shop—that you should immediately give him precedence over everybody else.

If your office is run systematically, you can tell after a moment's reflection just how the work is getting on, and what chances there are for getting a new job started in. Then you can tell your customer when he can have his work, within an hour or two, unless it is a job of considerable magnitude. Then if he says that is too late, tell him you are sorry, but you would rather lose the order than disappoint him in the delivery of it. Explain the situation fully to him, and it is ten chances to one he will leave the order.

If he does so, you must have that work ready when it is promised. One failure to keep your word in this respect will do you incalculable harm. Don't promise it a minute earlier than you have it ready, but never let the appointed hour go by without delivering the work.

So much for building up reputation. You will have

VIKING

25 pounds and over

10-POINT

Roman Rates

25 pounds and over

12-POINT

Roman Rates

BUSINESS IS BUSINESS

A reputation for promptness is one of the things that a job printer should strive for. He will have gained a great advantage when it comes to be said of him that he always gets work out on time, and it will pay him to endeavor to secure such a reputation by every means in his power. I know how prone is the ordinary business man to wait until he is clean out of stationery, or whatever he wants, before ordering more, or to postpone until the last possible moment the order for circulars, or handbills, or any other bit of commercial work; and then, when he does give you the order, he acts as though he thought his was the only work you had in your shop—that you should immediately give him precedence over everybody else.

If your office is run systematically, you can tell after a moment's reflection just how the work is getting on, and what chances there are for getting a new job started in. Then you can tell your customer when he can have his work, within an hour or two, unless it is a job of considerable magnitude.

THIS IS YOUR OPPORTUNITY.

A reputation for promptness is one of the things that a job printer should strive for. He will have gained a great advantage when it comes to be said of him that he always gets work out on time, and it will pay him to endeavor to secure such a reputation by every means in his power. I know how prone is the ordinary business man to wait until he is clean out of stationery, or whatever he wants, before ordering more, or to postpone until the latest possible moment the order for circulars, or handbills, or any other bit of commercial work; and then, when he does give you the order, he acts as though he thought his was the only work you had in your shop—that you should immediately give him precedence over everybody else.

IMPROVED LEADERS.

6-POINT.	EN DOT.	64 cts. per lb.
	EM DOT.	
	FINE DOT.	
7-POINT.	EN DOT.	56 cts. per lb.
	EM DOT.	
	FINE DOT.	
8-POINT.	EN DOT.	52 cts. per lb.
	EM DOT.	
	FINE DOT.	
9-POINT.	EN DOT.	48 cts. per lb.
	EM DOT.	
	FINE DOT.	

10-POINT.	EN DOT.	46 cts. per lb.
	EM DOT.	
	FINE DOT.	
11-POINT.	EN DOT.	44 cts. per lb.
	EM DOT.	
	FINE DOT.	
12-POINT.	EN DOT.	42 cts. per lb.
	EM DOT.	
	FINE DOT.	

Hyphen Leaders cast to order at the above prices.

RONALDSON LEADERS.

6-POINT.	EN DOT.	64 cts. per lb.
8-POINT.	EN DOT.	52 cts. per lb.

10-POINT.	EN DOT.	46 cts. per lb.
12-POINT.	EN DOT.	42 cts. per lb.

ROMAN AND ITALIC ACCENTS.

Put up in fonts or separate character, sold at pound rates

6-Pt. OLD STYLE No. 10

á à â ã ä å æ è é ê ë ì í î ï ï ó ô õ ö ù ú û ü ü ç ñ Å Ä Å Æ È É Í Ó Õ Ù Ñ Ç

8-Pt. OLD STYLE No. 10

á à â ã ä å æ è é ê ë ì í î ï ï ó ô õ ö ù ú û ü ü ç ñ Å Ä Å Æ È É Í Ó Õ Ù Ñ Ç

8-Pt. OLD STYLE No. 10 ITALIC

á à â ã ä å æ è é ê ë ì í î ï ï ó ô õ ö ù ú û ü ü ç ñ

10-Pt. OLD STYLE No. 10

á à â ã ä å æ è é ê ë ì í î ï ï ó ô õ ö ù ú û ü ü ç ñ Å Ä Å Æ È É Í Ó Õ Ù Ñ Ç

10-Pt. OLD STYLE No. 10 ITALIC

á à â ã ä å æ è é ê ë ì í î ï ï ó ô õ ö ù ú û ü ü ç ñ

11-Pt. OLD STYLE No. 10

á à â ã ä å æ è é ê ë ì í î ï ï ó ô õ ö ù ú û ü ü ç ñ

11 Pt. OLD STYLE No. 10 ITALIC

à

12-Pt. OLD STYLE No. 10

á à â ã ä å æ è é ê ë ì í î ï ï ó ô õ ö ù ú û ü ü ç ñ Å Ä Å Æ È É Í Ó Õ Ù Ñ Ç

6-Pt. OLD STYLE No. 12

8-Pt. OLD STYLE No. 12

á à â æ è é ê ë ì í î ï ï ó ô õ ö ù ú û ü ç ñ à à à æ è é ê ë ì í î ï ï ó ô õ ö ù ú û ü ç ñ

10-Pt. OLD STYLE No. 12

á à â æ è é ê ë ì í î ï ï ó ô õ ö ù ú û ü ç ñ Ç É È Ê

12-Pt. OLD STYLE No. 12.

à â ä é è ê ë ì í î ï ï ó ô õ ö ù ú ü ç Ç Ç

6-Pt. ROMAN No. 4.

á à â ã ä å æ è é ê ë ì í î ï ï ó ô õ ö ù ú û ü ç ñ Å Ä Å Æ È É Í Ó Õ Ù Ñ Ç

8-Pt. ROMAN No. 4.

á à â ã ä å æ è é ê ë ì í î ï ï ó ô õ ö ù ú û ü ç ñ Å È É Í Ó Ñ Ç Å È É Í Ó Ñ Ç È

10-Pt. ROMAN No. 4.

á à â ã ä å æ è é ê ë ì í î ï ï ó ô õ ö ù ú û ü ç ñ Å Ä Å Æ È É Í Ó Õ Ù Ñ Ç

10-Pt. No. 4 ITALIC.

á à â ã ä å æ è é ê ë ì í î ï ï ó ô õ ö ù ú û ü ç ñ

12-Pt. ROMAN No. 4.

á à â ã ä å æ è é ê ë ì í î ï ï ó ô õ ö ù ú û ü ç ñ Å Ö Û

12-Pt. No. 4 ITALIC.

á à â ã ä å æ è é ê ë ì í î ï ï ó ô õ ö ù ú û ü ç ñ

SWEDISH ACCENTS

Put up in fonts at 25 cents per body. Also sold as second-class rate per pound

ROMAN NO. 4.

8-Pt.

å ä ö Å Ä Ö

12-Pt.

å ä ö Å Ä Ö

OLD STYLE NO. 10.

6-Pt.

å ä ö Å Ä Ö

9-Pt.

å ä ö Å Ä Ö

10 Pt.

å ä ö Å Ä Ö

12-Pt. OLD STYLE NO. 10

å ä ö Å Ä Ö

RONALDSON OLD STYLE NO. 12.

6-Pt.

å ä ö Å Ä Ö

8-Pt.

å ä ö Å Ä Ö

8-Pt.

å ä ö Å Ä Ö

10-Pt.

å ä ö Å Ä Ö

10-Pt.

å ä ö Å Ä Ö

12-Pt.

å ä ö Å Ä Ö

10-Pt. FRENCH OLD STYLE.

å ä ö Å Ä Ö A Ä Ö

LATIN ANTIQUE.

8-Pt.

å ä ö

10-Pt.

å ä ö

12-Pt.

å ä ö

18-Pt.

å ä ö

DE VINNE.

8-Pt.

å ä ö Å Ä Ö

10-Pt.

å ä ö Å Ä Ö

12-Pt.

å ä ö Å Ä Ö

14-Pt.

å ä ö A A Ö

18-Pt.

å ä ö Å Ä Ö

6-Pt. BOLD FACE NO. 15.

å ä ö Å Ä Ö

HANSEN OLD STYLE.

6-Pt.

å ä ö Å Ä Ö

8 Pt.

å ä ö Å Ä Ö

10-Pt.

å ä ö Å Ä Ö

12-Pt.

å ä ö Å Ä Ö

14-Pt.

å ä ö

18-Pt.

å ä ö A Ä Ö

HOWLAND.

10-Pt.

å ä ö

12-Pt.

å ä ö

12-Pt. LATIN CONDENSED

å ä ö Å Ä Ö

LATIN CONDENSED.

10-Pt.

å ä ö Å Ä Ö

18-Pt.

å ä ö Å Ä Ö

24-Pt.

å ä ö Å Ä Ö

ACCENTS

8-Pt. POLISH, Roman No. 4 8-Pt. BOHEMIAN, Roman No. 4
ą ę ć ł ś ż Ź Ą Ć Ę Ł Ś š ů č ň ý z ř Ň Ř Š Ů Ý Ž Ž

8-Pt. DE VINNE
ã ö Å Ä Ö

8-Pt. BOLD FACE No. 15. 12-Pt. DE VINNE.
ó ò ó w ù ā ī ō ū ū œ è

12-Pt. LATIN CONDENSED
à á á ú ç

12-Pt. Typewriter 12-Pt. Stenograf
Á Í Ñ é í ñ Ä Ö Ū ä ä ö ü

6-Pt. Hansen Old Style 75 cents
À Á Á Á Á Ä È È È Ì Ó Ö Ū Ç Ñ

8-Pt. Hansen Old Style 75 cents
À Á Á Á Á È È È Ì Ó Ö Ū Ç Ñ

10-Pt. Hansen Old Style \$1.00

À Á Á Á Á È È È Ì Ó Ö Ū Ç Ñ
à á á á á è è è ì í î ï ò ó ô õ ù ú û ç ñ

12-Pt. Hansen Old Style \$1.00

À Á Á Á Á È È È Ì Ó Ö Ū Ç Ñ
à á á á á è è è ì í î ï ò ó ô õ ù ú û ç ñ

18-Pt. Hansen Old Style \$1.00

À Ä È É Ê Ö Û Ñ Ç
à á â ä è é ê ë ì í î ï ò ó ô õ ù ú û ù ñ ç

These accents also sold at second class rate per pound.

6-Pt. Buffalo 75 cents

À Á Á Á Á È È È Ì Ó Ö Ū Ç Ñ

8-Pt. Buffalo 75 cents

À Á Á Á Á È È È Ì Ó Ö Ū Ç Ñ
à á á á á è è è ì í î ï ò ó ô õ ù ú û ç ñ

10-Pt. Buffalo \$1.00

À Á Á Á Á È È È Ì Ó Ö Ū Ç Ñ
à á á á á è è è ì í î ï ò ó ô õ ù ú û ç ñ

12-Pt. Buffalo \$1.00

À Á Á Á Á È È È Ì Ó Ö Ū Ç Ñ
à á á á á è è è ì í î ï ò ó ô õ ù ú û ç ñ

18-Pt. Buffalo \$1.25

À Ä Å Æ Ä Á Ê È Ì
Ó Ö Ū Ç Ñ à á â ä ä ã
è é ê ë ì í î ï ò ó ô õ ù
ú û ü ç ñ

MODERN FRACTIONS.

Price per Font, 90c.

6-Pt. EN. 1 1 1 1 1 1 1 1 1 1 1 1	6-Pt. EM. 1/4 1/2 3/4 1/2 3/4 1/2 3/4 1/2 3/4	7-Pt. EN. 1 1 1 1 1 1 1 1 1 1 1 1
8-Pt. EN. 1 1 1 1 1 1 1 1 1 1 1 1	8-Pt. EM. 1/4 1/2 3/4 1/2 3/4 1/2 3/4 1/2 3/4	9-Pt. EN. 1 1 1 1 1 1 1 1 1 1 1 1
10-Pt. EN. 1 1 1 1 1 1 1 1 1 1 1 1	11-Pt. EN. 1/4 1/2 3/4 1/2 3/4 1/2 3/4 1/2 3/4	12-Pt. EN. 1 1 1 1 1 1 1 1 1 1 1 1

OLD STYLE FRACTIONS.

Price per Font, 90c.

6-Pt. EM. 1/4 1/2 3/4 1/2 3/4 1/2 3/4 1/2 3/4	8-Pt. EM. 1/4 1/2 3/4 1/2 3/4 1/2 3/4 1/2 3/4
9-Pt. EM. 1/4 1/2 3/4 1/2 3/4 1/2 3/4 1/2 3/4	
10-Pt. EM. 1/4 1/2 3/4 1/2 3/4 1/2 3/4 1/2 3/4	
11-Pt. EM. 1/4 1/2 3/4 1/2 3/4 1/2 3/4 1/2 3/4	
12-Pt. EM. 1/4 1/2 3/4 1/2 3/4 1/2 3/4 1/2 3/4	

MISCELLANEOUS SIGNS.

6-Pt. @ # \$ % ' ° × *	7-Pt. @ # \$ % ' ° × *	8-Pt. @ # \$ % ' ° × *	9-Pt. @ # \$ % ' ° × *
No. 1. × ± ÷ - · ∘ + = ∴	No. 2. × ± ÷ - · ∘ + = ∴		
10-Pt. + × ÷ - = @ # \$ % ' ° × *	No. 1. - +	No. 2. - +	
11-Pt. @ # \$ % ' ° × *	12-Pt. @ # \$ % ' ° × *	18-Pt. %	30-Pt. %

8-Point » » 10-Point « » »
Sold in any quantity by the pound and in fonts.

8-Point De Vinne Fractions

1/4 1/2 3/4 1/3 2/3 1/8 3/8 5/8 7/8 ¢ %

10-Point De Vinne Fractions

1/4 1/2 3/4 1/3 2/3 1/8 3/8 5/8 7/8 ¢ %

12-Point De Vinne Fractions

1/4 1/2 3/4 1/3 2/3 1/8 3/8 5/8 7/8 ¢ %

18-Point De Vinne Fractions

1/4 1/2 3/4 1/3 2/3 1/8 3/8 5/8 7/8 ¢ %

De Vinne Fractions 50 cents per font



10 cents each ♥ ♠ ♣ ♦ Card Pips
Set of 4, 25 cents 75 cents per font.

RECIPE SIGNS.

14-Pt. 5c. R	18-Pt. 5c. R	24-Pt. 10c. R	30-Pt. 10c. R
24-Pt. 10c. R	24-Pt. 10c. R	18-Pt. 5c. R	18-Pt. 5c. 12-Pt. 5c. 10-Pt. 5c. R R

Set of three 10 cents

SCRIPT LOGOTYPES

Boston 30-Pt. 25c. <i>Boston</i>	M, 30-Pt. 15c. <i>M</i>	190, 30-Pt. 15c. <i>190</i>
36-Point Lion 15c. 	24-Pt. 15c. 	60-Point Lion 25c. 

STARS.

Font Containing 4 of each size, 75c.



0 1 3 5 7 9 8 6 4 2

PARENTHESIS FOR JOB TYPE
On all bodies from 6 to 48-Point.
75 cents per Font

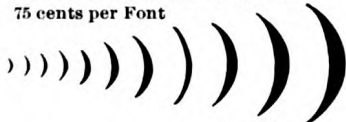

12-POINT
FANCY DASHES.

3-Em. 5c.



5-Em. 10c.



FISTS.

\$1.25 Per Font

6 to 12-Pt., 5c. ea., 18 and 24-Pt., 10c. ea., 30 and 36-Pt., 15c. ea.
13. 24-Pr. 3. 8-Pr. 1 6-Pr. 2 4. 8-Pr. 14. 24-Pr.

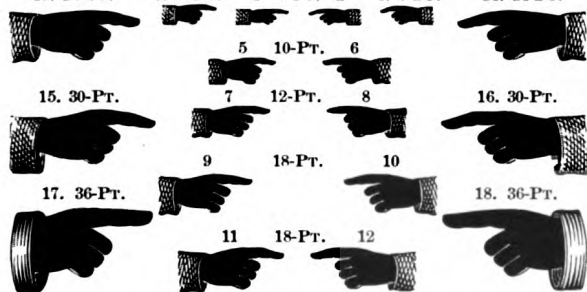

48-Point, 25 cents each.



24-Pt. Clover Leaf Border 20 inch font \$1.50

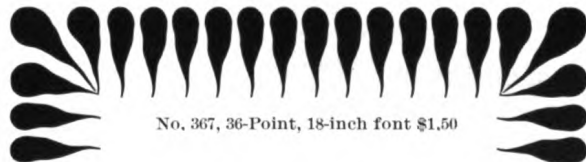

No. 367, 36-Point, 18-inch font \$1.50

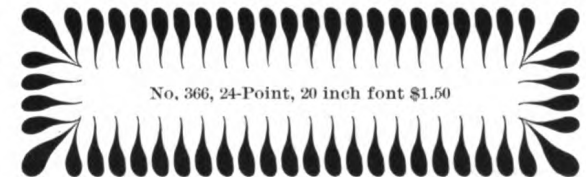

No. 366, 24-Point, 20 inch font \$1.50



No. 145, 18-Point, 48 inch font \$1.80



No. 141, 12-Point, 48 inch font \$1.50

22 a 16 A 6-POINT BOLD FACE No. 16. \$3.00

Bluebeard Fairy Tales
NIGHTINGALES SONGSTERS 1
Delighting The Children

18 a 14 A 10-POINT BOLD FACE No. 16. \$3.25

Magnificent Gardens
ELEGANT EXTENDED 3
Blooming Rose Buds

22 a 16 A 8-POINT BOLD FACE No. 16. \$3.25

Evening Amusements
EUROPEAN TRAVELLER 5
Climbing Mountains

16 a 12 A 12-POINT BOLD FACE No. 16. \$3.50

Athletic Stars
SWINGING CLUB
Horizontal Bars

10 a 7A 18-POINT BOLD FACE No. 16. \$4.25

SINCERE EPICURES
Eating Oatmeal and Milk 10

7 a 5 A 24-POINT BOLD FACE No. 16. \$5.50

MOONSHINERS
National 35 Banker

6 a 4 A 30-POINT BOLD FACE No. 16. \$3.50

DINE Steaks 8

24A 48a 6 Point Buffalo \$2 25

INTELLIGENCE AND INDUSTRY ARE THE BEST
 Our capacity to produce has developed so enormously
 and our products have so multiplied that the problem of
 more markets requires our urgent and immediate atten-
 tion Only a broad and enlightened policy will keep the

20A 36a 8 Point Buffalo \$2 35

NATIONAL POLICIES
ENCOURAGE INDUSTRY & COMMERCE.
 A system which provides a mutual exchange
 of commodities is manifestly essential to the

12A 18a 14 Point Buffalo

HANSEN COMPLETE MITERING MACHINE
 Miters all Angles accurately. It saves the Printer time

9A 15a 18 Point Buffalo \$3 30

PRINTING OFFICE FURNISHINGS
 To be obtained at 190-192 Congress Street.

5A 9a 24 Point Buffalo \$3 50

LEADS AND SLUGS
 the highest standard maintained



ÄÅÄÂÃÈÉÊÍÓÖÛÇÑ
 àáâãäåèéêëìíîïðóôöùúûüçñ



5A 8a

30 Point Buffalo

\$4 50

GUARD LINES Type=High

4A 6a

36 Point Buffalo

\$5 50

CALENDAR Figures

3A 4a

48 Point Buffalo

\$8 50

BRASS & Rules

3A 4a

60-Point Buffalo

\$13.00

NEW lodge

3A 4a

72-Point Buffalo

\$20.00

THE style

Great Shoe Sale Monday!



¹⁰ SEASONABLE SHOES FOR

¹⁸ Men, Women, Boys and Girls

⁸ Such an opportunity as this only comes once in a great while

¹⁴ *The* PRINCIPAL FEATURES ARE:

¹⁰ Women's \$5.00 Shoes, **\$2.35**

Regular lines and samples made in the Jenness-Miller Factory, Woburn

Women's \$3.50 Shoes, **99cts.**

Duplicates of all the new \$3.50 shoes shown in many of the leading stores

Women's \$1.50 Shoes, **65cts.**

Kid button and lace shoes, all styles

Men's \$5.00 Shoes at **\$ 2.60**
French Enamel and Patent Leather

Men's \$3.50 Shoes at **\$1.87**
Button and Lace, all styles and sizes

Boys' Shoes for sale at **98c.**
Kid and Calf lace with spring heels

Girls' \$1.25 Shoes sold at **75c.**

¹⁸ **MORRIGOLD SHOE COMPANY,**

¹² 18th and 19th Streets,

¹⁴ New York City.

Set in 8, 10, 14, 18, 30 and 36 Point Buffalo and 12, 14 and 18 Point Buffalo Outline

Buffalo Italic

16A 36a 6-Point Buffalo Italic \$2.00

GLOUCESTER STEEL BEDS

The greatest fishing centre in this country for any amount

14A 32a 10-Point Buffalo Italic \$2.50

SCIENTIFIC CASTING

Apple season and all apples on sale

10A 20a 14-Point Buffalo Italic \$3.00

THE MITERER

Intelligent Consideration

5A 8a 24-Point Buffalo Italic \$3.50

THE Machinery
12345

3A 6a 36-Point Buffalo Italic \$5.50

SEA Binns

14A 32a 8-Point Buffalo Italic \$2.25

AUTOMATIC MAIL DELIVERY

In the near future and rush the Matter three and

12A 25a 12-Point Buffalo Italic \$2.75

2 COMPILING EDITOR 8
Anxious about future prosperity

7A 16a 18-Point Buffalo Italic \$3.00

FINE POINT

Printing, embossing

4A 8a 30-Point Buffalo Italic \$4.25

NEW Wheel

3A 5a 48-Point Buffalo Italic \$8.50

ON sale

15A 22a 12-Point Buffalo Outline \$3 00

IMPROVED CURVING
12345 MACHINE 67890
The simplest and most useful

9A 15a 18-Point Buffalo Outline \$3 75

The UTILITY
paper cutter of *s a &*

12A 18a 14-Point Buffalo Outline \$3 25

NUMBERING MACHINE
Very useful for printers 25
The s of a &

5A 9a 24-Point Buffalo Outline \$4 00

The OUTLINE
for printers *& s a*

5A 8a 30-Point Buffalo Outline \$5 00

BORDERS & Ornaments &

4A 6a 36-Point Buffalo Outline \$6 00

CABINETS 9 for Type

3A 4a 48-Point Buffalo Outline \$9 00

RULE 28 Brass

HHHHHHHHHHHHHHHH

One Line, Unit Set

50 a 30 A 6-POINT HOWLAND. \$2.25

WASHINGTON CROSSING THE DELAWARE RIVER
Noonday Rambles Among The Orange Groves Down in Florida 57

40 a 28 A 8-POINT HOWLAND. \$2.50

INTERNATIONAL BROKERS MEMORANDUMS
We Carry a Full Line of Printing Inks and Bronzes 278

36 a 24 A 10-POINT HOWLAND. \$2.75

BECOMING MODES IN DRESS REFORM
Monumental Designs and Inscriptions Made 8643

16 a 10 A 24-POINT HOWLAND.

INSURANCE BROKERS Stock Market Quotations 7 \$4.00

12 a 8 A 30-POINT HOWLAND. \$5.00

CRUDE SONG BIRDS Good Singers 823

10 a 6 A 42-POINT HOWLAND. \$6.00

MORE SUNSHINE is Requested 801

8 a 5 A 48-POINT HOWLAND. \$7.00

NICER HORSE Clever Rider 8

30 a 20 A 12-POINT HOWLAND. \$3.00

MAKING BINDERS MORROCCO
Diplomatic Foreign Ministers Banquet 27
Revere House Centennial Celebration

20 a 12 A 18-POINT HOWLAND. \$3.25

HONEST MINERS RESUME
Surprise Party Entertainments 59

50 a 15 A 6-POINT TUDOR BLACK. \$2.25

In Time of Peace Prepare For Emergencies of War
Don't dare to Call Your Soul your Own, Don't dare to Have A
72 View That Isn't Just the Common Marangue 96

36 a 12 A 10-POINT TUDOR BLACK. \$2.75

Reproduce Some Antique Paintings
The Secret of Fine Printing is a Chain
95 Many Links And Experience 80

50 a 15 A 8-POINT TUDOR BLACK. \$2.75

When we Read Old Biographies we Find
The Best Portion of a Good Man's Life is His
12 Little Acts of Kindness and Love 34

30 a 9 A 12-POINT TUDOR BLACK. \$2.75

This is My Own, my Native Land
Free from a Tyrant's Hand 32

25 a 8 A

18-POINT TUDOR BLACK.

\$3.40

Select Ecclesiastical Christmas Printing
Memorial Resolutions Engrossed and Written 452

15 a 5 A

20-POINT TUDOR BLACK.

\$3.50

Florida Orange Groves in Blossom
Monumental Designs Artistically Cut 58

15 a 5 A

24-POINT TUDOR BLACK.

\$4.75

Opera Singers Entertained
Fine Pneumatic 6 Tired Bicycles

12 a 4 A

36-POINT TUDOR BLACK.

\$5.50

New Artistic 4 Trilby Shoes

12 a 4 A

42-POINT TUDOR BLACK.

\$6.00

Mansion 85 Gardeners

8 a 5 A

48-POINT TUDOR BLACK.

\$8.50

Grandest 7 Orations

24-Point Tudor Black Ornaments. Font, 60 Cents.



36 a 24 A	6-POINT DE VINNE.	\$2.25	30 a 22 A	8-POINT DE VINNE.	\$2.50
PROCRASTINATION MISERABLE EXISTENCE Success Necessitates Incessant Combating with Adverse 647			FLUENT SPEAKING REGULATED Denunciatory Men to Meet the Requirements 358		
26 a 20 A	10-POINT DE VINNE.	\$2.75	20 a 16 A	12-POINT DE VINNE.	\$3.00
THE SMOOTH GOOD MANNERS Gentlemanly Bearing and Courtesy are 92			PRIDE CAUSES POVERTY Much Scheming by Capitalists 56		
18 a 12 A	14-POINT DE VINNE.	\$3.25	16 a 10 A	18-POINT DE VINNE.	\$3.25
STUDY COMPOSITION Perfect Material is Better 483			DEBASING NEWS Pugilistic Affairs End 35		
10 a 8 A	24-POINT DE VINNE.				\$4.00
DISHONORABLE COMMANDER Opportunely Discharged November 25					
9 a 6 A	30-POINT DE VINNE.				\$5.00
HUMOROUS NEIGHBORS Beautify Earthly Homes 6745					

30A 42a 6-POINT DE VINNE CONDENSED \$2.25

WHEN THE MOON SHINES BRIGHTLY OVER THE HILL AND LIGHTS UP
the shadowy forest glen, then I'll meet you my De Vinne at the rill, when
the moon beams brightly over the hill De Vinne Condensed 234567

25A 36a 8-POINT DE VINNE CONDENSED \$2.50

THE MARKETS ARE WELL STOCKED WITH ALL THE
necessities of the season. Look for H. C. HANSEN'S new
place of business, 190-192 Congress Street, Boston, where
all orders receive prompt and careful attention in filling

22 A 30 a 10-POINT DE VINNE CONDENSED \$2.75

NEW TYPE AND BORDERS OF VARIOUS DESIGNS
All Type and Brass Rule made in this Foundry are of
the very best material. Also the very best make 25784

18A 22a 12-POINT DE VINNE CONDENSED \$3.00

LIFE INSURANCE IS A POINT GAINED.
Hard and Extra Tough Metal is 100 per cent.

12A 20a

14-POINT DE VINNE CONDENSED

\$3.25

THE ART OF MAKING ALL THINGS WELL
Type is made perfect in line. Brass Rules are also made even on the face
CAPITAL, \$1,234,567,890

10A 16a

18-POINT DE VINNE CONDENSED

\$3.25

MECHANICS' FAIR HELD AT BOSTON, 1902
Prizes will be awarded for the best Exhibits, Sept. and Oct.
All competitors are welcome to show goods

8A 12a

24-POINT DE VINNE CONDENSED

\$4.00

THE 30th ANNIVERSARY OF H. C. HANSEN,
1872 Now doing business on Congress St. 1902

36 a 24 A 6-POINT DE VINNE ITALIC. \$2.25

PRINTING IN ANCIENT DAYS WAS LABORIOUS
Typography Practiced in the Nineteenth Century is Improved 21

26 a 20 A 10-POINT DE VINNE ITALIC. \$2.75

BOMBARDMENT OF SANTIAGO CITY
American Battleship Oregon in the Fight 198

18 a 12 A 14-POINT DE VINNE ITALIC. \$3.25

EUROPEAN Monarch Crown

10 a 8 A 24-POINT DE VINNE ITALIC. \$4.50

MAILING Machine

30 a 22 A 8-POINT DE VINNE ITALIC. \$2.50

COMMERCIAL AND SOCIETY PRINTING
Many Candidates for Fine Government Positions 67

20 a 16 A 12-POINT DE VINNE ITALIC. \$3.00

PORTO RICO UNITED STATES
Surrendered to America October 18

16 a 10 A 18-POINT DE VINNE ITALIC. \$4.00

MODERN Typography 6

9 a 6 A 30-POINT DE VINNE ITALIC. \$5.75

GRAND Ball 8

8 a 5 A

36-POINT DE VINNE ITALIC.

\$6.50

BOSTONIAN Concerts 4

6 a 4 A

42-POINT DE VINNE ITALIC.

\$7.25

NICE Borders

5 a 4 A

48-POINT DE VINNE ITALIC.

\$7.75

FINEST Shoes 53

30A 44a 6-Pt. Stratford Old Style \$2.25

WE MUST ENCOURAGE OUR MERCHANT MARINE
 (We must have more ships. They must be under the American flag, built and manned and owned by Americans. They are most profitable.

26A 40a 8-Pt. Stratford Old Style \$2.50

PRICES ARE FIXED MATHEMATICALLY
 All Hansen's Type Faces are made on one line, unit set

22A 36a 10-Pt. Stratford Old Style \$2.75

COMPLETE PRINTING OFFICE OUTFIT
 carried in STOCK at 190-192 Congress Street

18A 28a 12-Pt. Stratford Old Style \$3.15

HANSEN COMPLETE MITERER
 is the best Mitering Machine in the world, saves you time and money \$18

12A 20a 18-Pt. Stratford Old Style \$3.60

WHEN PURCHASING
 look for Hansen's supplies

10A 15a 24-Pt. Stratford Old Style \$5.00

STRATFORD Old Style Type \$7890

8A 12a 30-Pt. Stratford Old Style \$6.00

CABINETS, Wood Furniture 16

6A 9a 36-Pt. Stratford Old Style \$7.00

MITERING Machine \$18.

4A 6a 48-Pt. Stratford Old Style \$8.00

NEW Type faces '02

60 a 30 A 6-POINT HANSEN OLD STYLE. \$2.50

THIS IS A NEW SIZE OF HANSEN OLD STYLE
 The Latest and Most Extensively Used Series for Artistic Printing
 Producing an Effect Pleasing to the Modern Typographer

35 a 25 A 8-POINT HANSEN OLD STYLE. \$2.75

FINE PRINTING MOST DESIRABLE
 Reproduction of Old Style Types of Ancient Times is now
 a Leading Feature in the Artistic Typography

30 a 25 A 10-POINT HANSEN OLD STYLE. \$3.00

THE INVENTION OF PRINTING
 Typographical Charms of the Century Shown

30 a 18 A 12-POINT HANSEN OLD STYLE. \$3.25

HUMOROUS COMEDIES

European Excursions to the Land of the
 Midnight Sun are Very Pleasant

25 a 15 A 14-POINT HANSEN OLD STYLE. \$3.50

MOONSHINE RIDERS

Inventors Flying Machines Prove
 Successful by 4 Recent Trials

20 a 12 A 18-POINT HANSEN OLD STYLE. \$4.00

GOOD SUMMER HOMES IN EUROPE
 Sailing on the Briny Deep for 350 days of Ocean Travelling

15 a 10 A 24-POINT HANSEN OLD STYLE. \$4.50

MODERNIZED COMPOSERS
 Great Subway built on  the Boston Common

ÀÁÂÃÄÅÈÉÊËÍÏÓÔÛÜŦÇàáâäåèéêëìíóôõöùúûüçñ

Accents made in 6, 8, 10, 12 and 18-pt., sizes, put up in separate fonts, shown on page 71

10 a 6 A

30-POINT HANSEN OLD STYLE.

\$5.00

FOUR HOUSES INSURED
Increased Rates for  Shipping North

8 a 5 A

36-POINT HANSEN OLD STYLE.

\$5.50

MORE HIGHER KINDS
Designing New Elegant Series 8

6 a 4 A

42-POINT HANSEN OLD STYLE.

\$6.00

REMINDER 24 Sunshines

5 a 4 A

48-POINT HANSEN OLD STYLE.

\$6.50

BRIDGE Ships Cargo 7

100a 30A 20A

6-Pt. French Old Style

\$3.50

HANSEN'S COMPLETE MITERING MACHINE IS "COMPLETE"
The best mitering machine in the world. Miters all angles accurately
THE POSSESSION OF WEALTH DOES NOT BRING HAPPINESS

60a 20A 10A

12-Pt. French Old Style

\$4.40

METAL FURNITURE LEADERS AND
Furniture and Reglet more Accurate than
BUY THE LEADING ARTICLES

90a 30A 15A

8-Pt. French Old Style

\$4.05

DUST PROOF FURNITURE KEEPS ALL TYPE
in fine condition and it will wear longer being protected by
TRUE MEN NEVER FRET ABOUT THEIR PLACE

75a 24A 12A

10-Pt. French Old Style

\$4.10

ALL THE POINT STANDARD QUADS ARE
made without nicks by H. C. Hansen, Boston.
THINK STRONGLY OF POINT STANDARD

36a 18A

16-Pt. French Old Style

\$4.50

PRINTERS NOW USE HANSEN'S SOLID BRASS GAUGES.
All the gauges are made with the brass overhanging the body

28a 14A

20-Pt. French Old Style

\$5.00

SPECIALTIES MADE BY H. C. HANSEN &
new Brass Rule for border effects and catalogues

20a 10A

24-Pt. French Old Style

\$5.50

METAL FURNITURE SAVES TIME IN
locking up blank forms and headings

60 a 20 A \$4.65

12-POINT STENOGRAP.

Extra Lower Case, with spaces, \$2.85

The conditions under which a typewriter produces its work are very peculiar, and the results obtained are, therefore, all the more difficult to imitate. The effect produced by this type was achieved by copying closely the actual work done on one of the latest improved machines. The common practice of having some letters out of alignment has been avoided because the improvements in typewriter machines make such work inexcusable, and an operator who does not do good work, on a modern machine, cannot retain her position.

Our effort has been to produce a type which shall, to a

100 a 20 A, \$7.00.

12-POINT TYPEWRITER.

Extra lower case, 100 a, \$5.00

The conditions under which a typewriter produces its work are very peculiar, and the results obtained are, therefore, all the more difficult to imitate. The effect produced by this type was achieved by copying closely the actual work done on one of the latest improved machines. The common practice of having some of the letters out of alignment has been avoided, because the improvements in typewriter machines make such work inexcusable, and an operator who does not do good work, on a modern machine, cannot retain her position.

Our effort has been to produce a type which shall, to a

BOLD FACE No. 15

32A 50a 6-Point Bold Face No. 15 \$2.25

ALL TYPE DISPLAYED BY H. C. HANSEN

is made in this Type Foundry, and made under one roof. All type faces shown in this Specimen Book are made by H. C. HANSEN. Thousands of special rules are made to order. Rule sold in two-foot strips. All orders receive prompt and careful attention. No order too large, and none too small to be handled in this Type Foundry. 19

CALL AND SEE THE DISPLAY.

18A 30a 8-Point Bold Face No. 15. \$2.50

ANCIENTS AND HONORABLES

Coming to visit Boston and friends in June
An elegant parade and sumptuous banquet
in the Cadet Armory, Boston.

A SAFE HOME VOYAGE TO ALL

18A 30a 10-Point Bold Face No. 15 \$2.75

EIGHT NEW BATTLESHIPS

To be the most powerful in the world
United States Navy increasing
Protecting Commerce and Harbors

26A 36a 7-Point Bold Face No. 15 \$2.50

SPECIAL HANDY BRACES (METAL)

Hansen's Handy Braces are made to save time and do away with piece braces, thus doing the work quickly and with better satisfaction for the printers that have to use a number of braces

A GREAT LABOR-SAVER

20A 30a 9-Point Bold Face No. 15 \$2.80

THE BOARD OF TRADE MEETING

held at the Comma Building

The "Waste Basket" furnished the Board
with amusement for the ensuing year 1903

NEXT MEETING FOR ARCHITECTS

14A 22a 12-Point Bold Face No. 15 \$3.00

LATEST FOREIGN NEWS

The Philippines under the
U. S. Government
Complete control accepted

30A 60a 6-Point Viking \$2 00

HAMILTON WOOD GOODS CARRIED IN STOCK TO A VERY
LARGE EXTENT.This Furniture makes a beautiful Printing Establishment for all
who are looking forward to making their office attractive

EVERYTHING IS MADE USEFUL

& 1245780 \$

25A 35a 8-Point Viking \$2 25

MAILING GALLEYS, BENZINE CANS, OIL CANS.

All supplies used in a Printery can be purchased from
H. C. Hansen, Congress Street, Boston, Massachusetts.

BRASS GALLEYS, WOODEN GALLEYS.

& 234567890 \$

25A 30a 10-Point Viking \$2 50

LINING TYPE IN VARIOUS SIZES.

Labor of the country constitutes its strength
and its wealth A noble manhood never dies

& 134567890 \$

18A 30a 12-Point Viking \$2 75

LEADS, SLUGS AND LEADERS

The fine dot leaders will save justifica-
tion where dotted lines are used

1234567890

15A 25a 16-Point Viking \$3 00

25 ABSOLUTE RELIABILITY TYPE DIAMOND NICK. 40

Diamond nicked type is readily distinguished from all others &

12A 20a 18-Point Viking \$3 30

"COLTS ARMORY" PLATEN PRINTING PRESSES

& For sale at 190-192 Congress Street, Boston, Mass. \$

10A 15a 24-Point Viking \$4.25

4680 EXTRA Tough Metal TYPE & 1325

6A 10a

30-PT. VIKING

\$4.50

FRANKLIN Hand Proof Press 230

5A 8a

36-PT. VIKING

\$4.75

CABINETS made Dust-Proof

4A 6a

42-PT. VIKING

\$5.00

450 THE latest Type 682

4A 5a

48-PT. VIKING

\$5.60

JUNE weddings 3.098

HHHHHHHHHHHHHHHHHHHHHHHHHHHHHH

This Series lines accurately at the bottom. Use Point System leads and slugs in justifying

28A 50a 6-Point Viking Italic \$2 00

VIKING ITALIC IS MADE TO CONFORM WITH THE VIKING. This type lines both top and bottom, and in composition produces a very fine effect for first-class work. H. C. Hansen's own manufacture. Made at 190-192 Congress Street, Boston, Massachusetts. TYPE, LEADS, SLUGS, METAL FURNITURE, BRASS RULES, WOOD FURNITURE, CABINETS, STANDS, RACKS, ETC. 1234567890

22A 30a 8-Point Viking Italic \$2 25

TYPE MADE OF COPPER, TIN AND ANTIMONY. Who can tell the new thoughts that have been awakened, the ambitions fired, and high achievements that will be wrought through this exposition? Let us ever remember that concord, not conflict; rests in the victories of peace, not those of war. COMPLETE PRINTING OFFICE FURNISHER. & 1234567890 \$

12A 20a

10-Point Viking Italic

\$3 00

THE PRODUCT OF H. C. HANSEN'S FOUNDRY can be seen throughout these Specimen Sheets. & \$ 1234567890

10A 26a

18-Point Viking Italic

\$3 30

NO ORDER TOO LARGE, NONE TOO SMALL, All orders receive the same careful and prompt attention.

8A 10a

24-Point Viking Italic

\$4 25

PRESSES, PAPER CUTTERS, INKS. Complete Outfits for all the Printing Offices.

20A 30a 10-Point Viking Italic \$2 50

HANSEN COMPLETE MITERING MACHINE Meters all angles accurately. See circular of the many advantages for which this Mitering Machine has been manufactured. Send orders to H. C. Hansen

15A 30a 12-Point Viking Italic \$2 75

SEND FOR THE SHEETS OF TYPE specimens. All samples of Type, Etc., shown are made from Copper, Tin and Antimony. The strongest production. & 1234567890 \$

Hansen Vertical Script

PATENT APPLIED FOR

35 a 10 A 12-POINT HANSEN VERTICAL SCRIPT

\$4.00

Vertical Script is Universally
Popular Among the Students of the
Leading Colleges in America

25 a 8 A

18-POINT HANSEN VERTICAL SCRIPT

\$4.75

Modern Penmanship
Graceful and Delicate Lines

22 a 7 A

24-POINT HANSEN VERTICAL SCRIPT

\$6.00

American Universal Constitution
Musical Pianoforte Recitals

15 a 5 A

30-POINT HANSEN VERTICAL SCRIPT

\$7.50

Vertical Writing in Schools 258

15 a 5 A

36-POINT VERTICAL SCRIPT

\$9.00

First National Bank

30A 6-POINT GOTHIC No. 1 (A) \$1.00

LEADS AND SLUGS SOLD IN THIS OFFICE ARE SUPERIOR TO ANY OTHER MAKE
NUMBERING MACHINES ARE VERY USEFUL ON A PRESS FOR ALL CLASSES OF WORK DONE.
1284667890

30A 50a 6-POINT GOTHIC No. 1. \$1.80

NEW TYPE, ALL CAPS LINE AT THE BOTTOM. USE POINT LEADS
AND SLUGS IN JUSTIFYING

The Boston Lead Rack for printers who desire to have a place for everything
and everything in its place, these racks are indispensable. They are made in 4
sections, from 4 to 69 ems pica, with the length of leads plainly stamped on top.

20A 40a 12-POINT GOTHIC No. 1. \$2.70

PORTER STEEL RUN CABINETS
FILLED WITH "DEPARTURE CASES"

The merits of these cases are well known.
They ride upon the side rails only, and the
bottoms do not come in contact with runs.

12A 20a

18-POINT GOTHIC No. 1.

\$3.25

H. C. HANSEN PERFORATING MACHINES

For durability, strength and general adaptability to the
purposes for which it is intended stands second to none.

8A 12a

24-POINT GOTHIC No. 1.

\$3.64

HANDY LETTER BOARD CABINETS
They are made of hardwood throughout

HHHHHHHH

30A 50a 8-POINT GOTHIC No. 1. \$2.30

PATENT INTERLOCKING DRYING RACKS MAY BE STACKED
ceiling-high, in a perfectly straight and rigid pile, which can-
not be knocked over by accident, and with no more weight
on the bottom than on the top sheets. Makes a fine dry room
INDISPENSABLE FOR A SMALL OFFICE 12480

25A 40a 10-POINT GOTHIC No. 1. \$2.25

INK AND ROLLER CABINETS ARE A NECESSARY
ARTICLE FOR PRINTERS USE.

The use of it will result in the saving of ink and rollers,
which will speedily pay for cost of Cabinet. Shelf for
ink, brayer and ink slab, and brackets to hold rollers. 75

40A 62a 8-POINT GOTHIC CONDENSED No. 2. \$2.70

COMPOSING AND MAKE-UP RULES
IN ORDERING RULES BE SURE AND GIVE EXACT SIZES.

The nickel rules are perfectly smooth and make composition easy and rapid, and the compositor can set type much faster and with less chance for "pi" in the stick. All the

LATEST MODERN IMPROVEMENTS

24A 36a 12-POINT GOTHIC CONDENSED No. 2. \$3.06

PERFECTION RULE CASE

Will hold about twenty pounds of Labor-saving brass rule. Four fit in a blank case
Printers are invited to call and examine the

HARRIS RULE CASE THEY ARE A
GREAT IMPROVEMENT

28A 44a 10-POINT GOTHIC CONDENSED No. 2. \$2.50

PREMIUM CARD CUTTER, \$10.00

A distinctive advantage is secured by a peculiar arrangement of the joint, by means of which a sheet of any length may be cut by the adoption of a spring overhead, and connected by a cord.

16A 24a 18-POINT GOTHIC CONDENSED No. 2. \$3.20

WROUGHT IRON CHASES

Warranted square and true, and
made of the best material.

COMBINATION PAPER JOGGER

12A 20a 24-POINT GOTHIC CONDENSED No. 2. \$3.75

SCREW COMPOSING STICKS, ADJUSTABLE KNEE

Patent All-Brass Galleys, Mustang Mailing Galleys, Etc.

HHHHHHHHH

This Series lines at the bottom Use point leads and slugs in justifying

24A 50a 6-PT. GOTHIC CONDENSED No. 3. \$1.75

**SANSPAREIL HARRIS RULE CASE. IT SURPASSES ALL OTHERS.
EMBODIES ALL THE GOOD FEATURES IN A RULE CASE.**

It protects the rule and it cannot fall flat. Rule is easy to extract and each case is complete. Capacity is large and durable and a time saving rule case.

**NEWS CASES, ITALIC CASES, BOOK AND JOB CASES
YANKEE JOB CASES, ETC.**

20A 40a 10-PT. GOTHIC CONDENSED No. 3. \$2.25

THE POWER IMPROVED PIN-HOLE PERFORATOR

It consists of two die wheels placed in such a position as to register perfectly, with no gearing to get out of order. May be run by hand or power

12A 25a

18-PT. GOTHIC CONDENSED No. 3.

\$3.20

PRINTING INKS, BRONZES, PAD CEMENT, PASTE, ETC., ETC.

Everything for Printers can be purchased at this office. 190

9A 18a

24-PT. GOTHIC CONDENSED No. 3.

\$3.50

**THE STANDARD TYPE MEASURES FOR SETTING
the Measure and having it accurate while setting. 87**

24A 50a 8-PT. GOTHIC CONDENSED No. 3. \$2.10

**BRASS CLAMPS FOR CURVED LINES. CORNER QUADS
LABOR-SAVING BRASS LEADERS**

Printers will readily see the economy of having Leaders made from solid brass. Fonts of five pounds or more \$1.50 per lb.

BRASS BRACES AND HALF BRACES

15A 30a 12-PT. GOTHIC CONDENSED No. 3. \$2.30

**SQUARE LEG TABLE AND COMPOSING
STONES**

Imposing Frames are made of hardwood in knock-down form. This is convenient

Marble, \$1.00 per square foot

6A 12a

30-PT. GOTHIC CONDENSED No. 3.

\$3.50

CABINETS, Stands and Wood Furniture 6

12 a 6 A

36-POINT GOTHIC CONDENSED No. 3.

\$4.90

RECONSIDERATION Indiscriminate 10

8 a 5 A

42-POINT GOTHIC CONDENSED No. 3.

\$4.70

PRINTERS Supplies consists 69

8 a 5 A

48-POINT GOTHIC CONDENSED No. 3.

\$6.20

RULES and Best machines

36A 70a 6-PT. GOTHIC CONDENSED No. 4. \$2.16

ALL MODERN IMPROVEMENTS IN THE ART OF TYPE MAKING AND CASTING are contained in H. C. Hansen's commodious Quarters, 190-192 Congress St., Boston, where all orders receive prompt attention and immediate delivery of
THE JOHN THOMSON COLTS ARMORY PRESS

32 A 56a 8-PT. GOTHIC CONDENSED No. 4. \$2.03

METAL FURNITURE AND QUOTATIONS ARE FINISHED SO AS to Justify accurately with Point Standard Type. Quads and spaces without nicks have proved to be of great advantage for Printers in
1234567890 FIGURES ARE MADE TO POINT

20A 40a 10-PT. GOTHIC CONDENSED No. 4. \$1.70

BORDERS AND BANDS IN MANY DIFFERENT EFFECTS
From Original Designs Made to Order
All rules made in this Type Foundry See specimen book
HANSEN Type Founder Telephone 2738

18A 36a 12-PT. GOTHIC CONDENSED No. 4. \$2.15

THE BRASS RULE CURVING MACHINES FOR Making any Desired Size of Circles very rapidly Small and compact; it requires very little space.
ALL ORDERS FILLED HERE

12A 26a 18-PT. GOTHIC CONDENSED No. 4. \$2.25

FINE CABINETS AND STANDS. 1903 labor-saving wood furniture case contains 1,530 pieces of furniture from 2

9A 18a 20-PT. GOTHIC CONDENSED No. 4. \$2.40

WROUGHT IRON CHASES AND Stereotype Blocks. In ordering a set of blocks state whether patent

9A 18a 24-PT. GOTHIC CONDENSED No. 4. \$3.30

NUMBERING MACHINES
Composing Sticks, Rules &
PRINTING MATERIALS

6A 12a

36-PT. GOTHIC CONDENSED NO. 4

\$4.60

13579 NEW RULES 24680
HANSEN'S Complete Mitering Machines

5A 10a

42-POINT GOTHIC CONDENSED NO. 4.

\$4.50

HARDWARE for Practical Printers use

5A 10a

48-POINT GOTHIC CONDENSED NO. 4.

\$6.00

GREAT quotation sale and \$15.

36 A 6-POINT GOTHIC CONDENSED, No. 5. 1.25
**BEAUTIFUL COMPOSITIONS CAREFULLY COMPILED FOR ENTERTAINMENT
 APPRECIATED BY PROPRIETORS AND PROOFREADERS 390**

30 A 10-POINT GOTHIC CONDENSED, No. 5. 1.50
**HANDSOME NEW YORK NEWSPAPER BROADWAY
 MEMBERS INITIATED MONTHLY 358**

18 A 18-POINT GOTHIC CONDENSED, No. 5. 1.50
EVEN FROM PURE SELFISHNESS 682

12 A 24-POINT GOTHIC CONDENSED, No. 5. 2.25
FROM PHILADELPHIA 504

6 A 42-POINT GOTHIC CONDENSED, No. 5. 2.80
MAINTAINING 37

32 A 8-POINT GOTHIC CONDENSED, No. 5. \$1.35
**DIRECTORY COMPLETED THE METHODIST CONFERENCE
 SESSION FOR UNEMPLOYED WORKMEN 359**

20 A 12-POINT GOTHIC CONDENSED, No. 5. \$1.15
**IMPORTANT PUBLISHERS BORROWING MATTER
 INDIVIDUALS HOLDING SITUATIONS 670**

18 A 20 POINT GOTHIC CONDENSED, No. 5. \$2.10
MANCHESTER BURLINGTON 35

8 A 36-POINT GOTHIC CONDENSED, No. 5. \$2.70
ADVERTISEMENT 2

4 A 48-POINT GOTHIC CONDENSED, No. 5. \$2.75
MENTION 89



45 a 28 A 6-POINT EXT. LINING GOTHIC No. 906. \$4.25

FINE EXTENDED GOTHIC

War Talk Makes 25 Presidents

32 a 22 A 10-POINT EXT. LINING GOTHIC No. 910. \$4.75

GOOD SENTIMENT

The Coming 6 Woman

22 a 15 A 14-POINT EXT. LINING GOTHIC No. 914. \$5.50

EXCURSION

Tourist 9 Boats

40 a 25 A 8-POINT EXT. LINING GOTHIC No. 908. \$4.50

SCIENTIFIC CASTING

Maxim Guns 34 Treasure

26 a 16 A 12-POINT EXT. LINING GOTHIC No. 912. \$5.00

MERRY MAID

Grand 8 Scenery

15 a 12 A 18-POINT EXT. LINING GOTHIC No. 918. \$6.00

ENGINES

Elated 6 Girls

12 a 9 A

24-POINT EXT. LINING GOTHIC No. 924.

\$7.00

FOREIGN 5 Noblemen

9 a 6 A

30-POINT EXT. LINING GOTHIC No. 930.

\$8.25

RIDING 9 Horses

This Series lines accurately at the bottom. Use Point System leads and slugs in justifying

MMMMMMMMMMMMMMMMMMMM

- 24A 50a 6-POINT GOTHIC No. 6. (A) \$2.10
COMMODIOUS QUARTERS, 190-192 CONGRESS STREET, BOSTON, CONTAINING 18,000 SQUARE FEET OF FLOOR SPACE
The Latest New Brass Rules are up-to-date and very attractive for fine display work in Magazines, Newspapers, Book and Pamphlet work, etc
COMPLETE PRINTING OFFICE FURNISHINGS
- 24A 50a 6-POINT GOTHIC No. 6. (B) \$2.10
HOERNER COMBINATION SHUTEBOARD AND TYPE-HIGH MACHINE, PRICE, \$23.75 NET.
This is an invaluable machine in all offices which use cuts to any extent. Cuts that are high can be brought to type height quickly.
CAN ALSO BE USED AS A BENCH VISE FOR HOLDING BLOCKS.
- 24A 50a 6-POINT GOTHIC No. 6. (C) \$2.10
NEWSPAPER, BOOK AND JOB TYPE FOR ALL OFFICES SOLD BY H. C. HANSEN
The location is in the center of the business district and all orders can be delivered at the shortest possible notice
190-192 CONGRESS STREET, BOSTON.
- 20A 40a 8-POINT GOTHIC No. 6. \$2.35
FURNISH YOUR OFFICE WITH HAMILTON WOOD GOODS
A great variety of Cabinets, Lead Racks, Furniture Racks, Letter Boards, Galley Cabinets.
EVERYTHING FOR YOUR PRINTING OFFICE.
- 15A 30a 10-POINT GOTHIC No. 6. \$2.10
PRINTERS ARE BUYING A LARGE QUANTITY OF TYPE
Metal from which Hansen's type is made is alloyed with copper, tin & antimony
HARD AND EXTRA-TOUGH METAL
- 12A 25a 12-POINT GOTHIC No. 6. \$2.20
BRASS RULE IS MADE BY PRACTICAL WORKMEN
Order your rules, circles and ovals. Special designs made to order.
THE LATEST NEW BRASS RULE.

24A 40a 6-Point Medium Gothic No. 7 \$2 25
ALL TYPE, LEADS AND SLUGS MANUFACTURED BY H. C. HANSEN, ARE MADE
from Copper, Tin and Antimony.
HAVE THE HANSEN MITERING MACHINE IN YOUR OFFICE

22A 32a 8-Point Medium Gothic No. 7 \$2 50
HANSEN'S TYPE MADE TO JUSTIFY WITH LEADS AND SLUGS
This enables the compositor to justify accurately and quickly and
without the use of paper and cardboard. 1234567890

20A 26a 10-Point Medium Gothic No. 7 \$2 75
NEW BRASS RULES ARE UNIQUE AND ARTISTIC
Originated for the printing trade by H. C. Hansen. In
effect of black and white they are elegant \$ 1257

16A 20a 12-Point Medium Gothic No. 7 \$3 00
GOOD SALESMEN SELL HANSEN'S TYPE
When purchasing see that you buy Hansen's

12A 18a 14-Point Medium Gothic No. 7 \$3 00
A COMPOSITION STUDY IN TYPE
Black and White and Embellishment

12A 18a 18-Point Medium Gothic No. 7 \$3 20
ROUND CORNER MACHINE
& Good effects in printing 2

9A 12a 24-Point Medium Gothic No. 7 \$3 75

45 NEWEST GOODS & LATEST STYLES 80
to be found at 190-192 Congress St., Boston.

7A 10a 30-Point Medium Gothic No. 7 \$4 25

PRINTING OFFICE FURNISHINGS
can be had in quantities at Hansen's

6A 9a

36-Point Medium Gothic No. 7

\$5 00

**COLTS ARMORY PRESSES
Platen Printing and Embossing**

5A 8a

42-Point Medium Gothic No. 7

\$6 50

ELEGANT 25 and Printing

4A 6a

48-Point Medium Gothic No. 7

\$7 00

PAPER \$37 Holidays



This Series lines accurately at the bottom, Use Point System leads and slugs in justifying

¹⁸
THE BRONX SHOE STORE,
¹⁴
1781 Washington Street, Boston.

LADIES' Kid lace or button boots, \$2.37

These boots are from the leading factories and are very choice goods, among which are gondolas with enamel top, lace or button with french toe, also common sense boots for comfort. All these boots are worth \$5.00 a pair direct from the factory, and we are closing them out.

LADIES' Gondola Vici Kid boots, \$1.85

Button and lace all styles and sizes, marked for this sale at the above tremendous reduction. All the boots are warranted to be equal to the highest class boots on the market, and this is your opportunity to purchase.

BOYS' Calfskin, with spring heel, \$1.39

This line of boys' calf, spring heel, are superior to the old style heel, and adds great elasticity to the step, we have them in all sizes, button or lace, also fancy toes. All these boots are to be closed out at this great sale.

GIRLS' Kid, lace or button, flat heel, \$1.50

Lace boots are made both in plain and fancy styles for girls, some have a double row of stitching up the front and around the top, and very fancy eyelet fastenings.
 8-Pt. No. 4.

⁴⁸ ³⁰
HOLIDAY SALE

AND

³⁰
Great Mark Down
²⁴
OF FOOTWEAR

¹²
MEN'S Riding boots, "special," \$7.25

The very finest sporting boots made, and at this price cannot be equalled. They are the very top-notch of perfection, and every horseman will appreciate this sale.

MEN'S Storm Boots, all styles, \$3.49

The storm boots are made on the new pattern, with the double back strap and reinforced tongue to prevent the moisture from penetrating to the foot of the purchaser.

MEN'S Calf, button or lace shoe, \$2.87

Men's calf shoes are made glove fitting with the swell strap for wet weather, and can be adjusted at a single moment. If you need a dry winter shoe, this is the one.

40 A 6-POINT VICTORIA ITALIC No. 5. \$1.75
AT THE BEGINNING OF THE SEVENTEENTH CENTURY
OLD ITALIAN BIBLIOGRAPHERS USED UNIFORM INITIALS ONLY 2345

40 A 6-POINT VICTORIA ITALIC No. 4. \$1.90
ONE OF THE FIRST PURPOSES EARLY PRINTING
WAS APPLIED TO WAS THE MANUFACTURE OF ENGRAVINGS

30 A 6-POINT VICTORIA ITALIC No. 3. \$1.75
THIS SERIES IS APPROVED OF BY THE MOST
SKILLFUL PRINTERS AS AN ARTISTIC DISPLAY TYPE

30 A 6-POINT VICTORIA ITALIC No. 2. \$2.00
FINE TYPOGRAPHICAL PRODUCTIONS
HALF TONE ENGRAVINGS OF MARINE VIEWS 3

30 A 6-POINT VICTORIA ITALIC No. 1. \$2.25
SANTIAGO HAS SURRENDERED
AMERICANS TAKE THE CITY BY STORM

18 A 12-POINT VICTORIA ITALIC No. 3. \$1.75
SPANISH POSSESSIONS
ON CUBAN SOIL ARE DOOMED 5

18 A 12-POINT VICTORIA ITALIC No. 2. \$2.00
EUROPEAN BANKS
INVESTMENTS SECURE

18 A 12-POINT VICTORIA ITALIC No. 1. \$2.30
RICH MERCHANT
MONEY BROKERS 26

12 A 18-POINT VICTORIA ITALIC No. 2. \$2.60

FINE AMERICAN WARSHIPS

12 A 18-POINT VICTORIA ITALIC No. 1. \$3.20

GRAND OCEAN FISH SOUPS

8 A 24-POINT VICTORIA ITALIC No. 2. \$3.25

FISHING GROUNDS

8 A 24-POINT VICTORIA ITALIC No. 1. \$3.75

STONE MONUMENTS

THIS SERIES LINES ACCURATELY AT THE BOTTOM.

12A 18a

18-Point Boston Gothic

\$3.20

**THIS IS THE TYPE TO BE USED FOR NEWSPAPER ADS.
Made by H. C. Hansen, Type Founder, 190-192 Congress St.**

9A 12a

24-Point Boston Gothic

\$3.75

**WHEN INTENDING TO PURCHASE PRINTING
Material, etc., call on H. C. Hansen, Boston.**

7A 10a

30-Point Boston Gothic

\$4.25

**H. C. HANSEN, COMPLETE PRINTING
Office Furnisher. Large Selections.**

6A 9a

36-Point Boston Gothic

\$5.00

**TYPE, LEADS, SLUGS, QUADS,
Metal Furniture, Quotations, Etc**

5A 8a

42-Point Boston Gothic

\$6.50

USE HANSEN'S LEADS &
Slugs, they are Superior.

4A 6a

48-Point Boston Gothic

\$7.30

WHITE MONUMENTS
the standard of earth

HHHHHHHHHH

This Series lines accurately at the bottom. Use point leads and slugs in justifying.

24A 50a 6-POINT GOTHIC No. 8. \$2.60

**SEE HANSEN'S SPECIMEN BOOK FOR DISPLAY
OF NEW TYPE**
Gloucester Celebrating Its 250th Anniversary
LEADS, SLUGS, BRASS RULES, ETC.

20A 40a 8-POINT GOTHIC No. 8. \$2.80

MECHANICS EXHIBITION, BOSTON
The Exhibit of H. C. Hansen's was the
most complete from a printers view.
GRAND HALL BASEMENT

16A 32a 10-POINT GOTHIC No. 8. \$2.75

TYPE FOR NEWSPAPERS &
all kinds of book work to be had
from H. C. Hansen, Type Founder
BOSTON, MASS.

16A 24a 12-POINT GOTHIC No. 8. \$3.10

SEE NEW BRASS RULES
Intelligent Consideration 28
Moulds, Dies, Matrices

12A 20a 16-POINT GOTHIC No. 8. \$3.25

LEADING FURNITURE.
In fitting up your office be
sure and consult Hansen's
Specimen Book

8A 12a 20-POINT GOTHIC No. 8. \$3.35

QUOTATIONS and
take slugs for news-
papers, etc. **\$1,234**

6A 10a 24-POINT GOTHIC No. 8. \$3.95

RULES, ETC.,
Leads and slugs
23 Cabinets 56

4A 6a

30-POINT GOTHIC No. 8.

\$4.40

MEN Buy high duty on 5

4A 6a

36-POINT GOTHIC No. 8.

\$5.00

TOOLS, Merchandise

4A 6a

42-POINT GOTHIC No. 8.

\$5.90

THE Rule Curver 6

4A 5a

48-POINT GOTHIC No. 8.

\$7.70

LODE water to

HHHHHHHHHHHHHHHHHHHHHHHHHHHHHH

This Series lines accurately at the bottom. Use Point leads and slugs in justifying

36 A 6-POINT LINING GOTHIC, No. 20. \$1.25

BE SURE THAT ALL LEADS AND SLUGS USED IN YOUR OFFICE IN THE FUTURE, IF NOT NOW, ARE MANUFACTURED BY H. C. HANSEN. THEN YOU WILL ALWAYS HAVE THEM EQUAL HEIGHT, THICKNESS AND PERFECTLY SQUARE, WHICH SAVES YOU TIME AND MONEY. THEY ARE MADE OF THE BEST MATERIAL AND HAVE NO EQUAL. YOU CAN OBTAIN A POUND OR A TON, FULL LENGTH, OR CUT OF ANY THICKNESS, AT SHORT NOTICE. REMEMBER THAT THEY ARE MADE AT 190-192 CONGRESS STREET, BY H. C. HANSEN, WHO HAS SPENT OVER TWENTY-FIVE YEARS MAKING IMPROVED MACHINERY WHICH IS NOT EQUALLED. 640

36 A 6-POINT LINING GOTHIC, No. 21. \$1.25

METAL FURNITURE, WOODEN FURNITURE, REGLETS, BOTH HARD AND SOFT WOOD, MITER BOXES AND SAWS, MARBLE INK SLABS, BRASS CIRCLES, OVALS, AND ORIGINAL DESIGNS MADE TO ORDER. STEEL CUTTING RULES AND PUNCHES AND ALSO HUNDREDS OF OTHER LABOR-SAVING DEVICES FOR PRINTERS USE CAN BE OBTAINED AT 190-192 CONGRESS STREET, BOSTON, WHERE EVERYTHING IN THE PRINTING LINE IS CARRIED IN STOCK, AND ORDERS FILLED AT THE SHORTEST POSSIBLE NOTICE 1234567

32 A 6-POINT LINING GOTHIC, No. 22. \$1.50

NEW BRASS RULES DESIGNED BY H. C. HANSEN, AND SHOWN IN THIS SPECIMEN BOOK, ARE THE MOST ARTISTIC FOR MAGAZINES, CATALOGUES, AND NEWSPAPER WORK. SEE SPECIMEN SHEET. IF YOU ARE IN NEED OF A "TASTY" RULE, GIVE H. C. HANSEN A CALL AND YOU WILL BE FITTED OUT WITH ANY RULE YOU MAY DESIRE. ALL RULE MADE IN TYPE FOUNDRY, 190-192 CONGRESS ST.

32 A 6-POINT LINING GOTHIC, No. 23. \$1.50

TO FURNISH A FINE OFFICE FOR UP-TO-DATE WORK, YOU SHOULD HAVE THE BEST FURNITURE ON THE MARKET. H. C. HANSEN CARRIES A COMPLETE LINE IN STOCK, AND ALL ORDERS RECEIVED BY HIM WILL BE ATTENDED TO AT VERY SHORT NOTICE

18 A 12-POINT LINING GOTHIC, No. 24. \$1.50

MAILING MACHINES AND CALLEYS
MALLETS, PLANERS AND QUOINS.
CARD CUTTERS, BENCH CUTTERS,
PRINTING INKS AND BRONZES. 235

14 A 12-POINT LINING GOTHIC, No. 25. \$1.50

ALL RULES MITERED UPON
H. C. HANSEN'S MITERING
MACHINE ARE ACCURATE 8

12 A 12-POINT LINING GOTHIC, No. 26. \$1.50

H. C. HANSEN'S EXHIBIT
AT MECHANICS FAIR
WAS COMPLETE IN ALL
ITS DETAIL. 1902

10A 18-POINT LINING GOTHIC, No. 27. \$2.00

ALL TYPE, LEADS, SLUGS, BRASS RULES, ETC.
MADE IN THIS TYPE FOUNDRY, BOSTON, MASS.

8A 18-POINT LINING GOTHIC, No. 28. \$2.00

BRASS GALLEYS & WOODEN GALLEYS
12345 MADE IN VARIOUS SIZES 67890

6A 24-POINT LINING GOTHIC, No. 29. \$2.00

FURNISHINGS FOR A COMPLETE
PRINTING OFFICE AT ONCE 1245

6A 24-POINT LINING GOTHIC, No. 30. \$2.00

BRASS LEADERS FOR TIME
25 AND LABOR-SAVING 90

HHHHHHHHHHHHH H HHHHHHHHHHHH

18A 40a

6-Point Gothic Italic

\$3.50

BRASS RULES, LEADS, SLUGS, QUADS, METAL FURNITURE, METAL QUOTATIONS, ETC.
Printers are supplied at once with the above articles and everything to complete a printing office outfit.

15A 30a

8-Point Gothic Italic

\$3.75

HANSEN'S PIN HOLE PERFORATOR RECEIVED THE HIGHEST AWARD
It consists of two die wheels placed in such a position as to register perfectly. \$50

12A 25a

10-Point Gothic Italic

\$4.00

EVERY LETTER SHOWN IN THIS SPECIMEN BOOK
Is cast by Hansen at his quarters. Machinery supplied for \$12345

10A 20a

12-Point Gothic Italic

\$4.25

PRINTERS PROFIT BY USING
Hansen's Manufactures. \$1234567 Sorts Immediately

8A 12a

18-Point Gothic Italic

\$4.50

TAKE NOTICE TO LINING SYSTEM
Justifies with point leads and slugs. Made
by H. C. HANSEN, Type Founder

6A 10a

24-Point Gothic Italic

\$5.00

HANSEN'S MANUFACTURES
are the first to arrive in your office

36 A 6-POINT INCLINED GOTHIC No. 40 \$1.25

*PRESCRIPTIONS CAREFULLY COMPOUNDED FROM LEAD
TIN COPPER AND THE FINEST ANTIMONY*

34 A 6-POINT INCLINED GOTHIC No. 41 \$1.25

*ALL FIGURES ARE CAST ON POINT THICKNESSES TO
EASILY JUSTIFY CALENDAR OR TABULAR WORK*

28 A 6-POINT INCLINED GOTHIC No. 42 \$1.25

*MODERN IMPROVEMENTS IN MANUFACTURING
TYPE OF THE HIGHEST STANDARD 2*

26 A 6-POINT INCLINED GOTHIC No. 43 \$1.25

*HOURS OF YOUTH FLEETING RAPIDLY AWAY
SECURE YOUR FORTUNE EARLY 36*

26 A 12-POINT INCLINED GOTHIC No. 44. \$2.00

*FIRST GRAND ENTERTAINMENT OF
THE DARKTOWN SOCIETY*

24 A 12-POINT INCLINED GOTHIC No. 45. \$2.00

*OLD ORCHARD BEACH PIER
MASCONOMA HOUSE*

20 A 12-POINT INCLINED GOTHIC No. 46. \$2.00

*EIGHTEENTH SEASON
GRAND OPERA 4*

15 A 18-POINT INCLINED GOTHIC No. 47. \$2.75

SWEET LINGERING MUSICAL SOUND

12 A 18-POINT INCLINED GOTHIC No. 48. \$2.80

BOSTON PRODUCERS 5

8 A 24-POINT INCLINED GOTHIC No. 49. \$2.95

AMERICAN HEROES 18

LINING FACE LINING FACE

8A 12a

18-Point Eclat

\$1 50

THE STERLING ROUND CORNERING CUTTER, REASONABLE IN PRICE AND Rapid. Designed to meet the requirements of Printers and Bookbinders

6A 10a

24-Point Eclat

\$2 10

EUROPES COURIERS ARE TRAVELERS
Steel Figures, entirely automatic, no better workmanship

5A 8a

36-Point Eclat

\$3 25

NEWSPAPER, Book and Job Type. 1903

4A 6a

42-Point Eclat

\$4 05

BRASS GAUGES essential 250

HHH H HHH

This Series lines at the bottom. Use Point leads and slugs in justifying

8A 12a

18-Point Eclat Outline

\$2 50

THE JONES GORDON PRESS. THE STRONGEST BRACED PRESS MADE. 25 self-locking chase-hook and form-starter. & A constant stock on hand

6A 10a

24-Point Eclat Outline

\$3 35

HALF-TONE SOFTENER & PUNCHES

For softening harsh vignettted edges of illustrations etc

5A 8a

36-Point Eclat Outline

\$4 70

TYPE, PRESSES and Cabinet supplies 6

4A 6a

42-Point Eclat Outline

\$5 65

OUTLINE FOR the Eclat Series



This Series lines at the bottom Use point leads and slugs in justifying

50 a 36 A 10-POINT LATIN CONDENSED. \$2.75

WE CARRY A FINE LINE OF INKS AND BRONZES

Paste, Pad Cement, Mailing Machine Gum and all Supplies 25

40 a 20 A 12-POINT LATIN CONDENSED. \$2.15

TERMINATION POETIC MOONLESS RAMBLES

Soul Inspiring Glances of a Maiden of Doubtful Age 78

30 a 18 A 18-POINT LATIN CONDENSED. \$3.20

INTERESTING REMINISCENCES

From the Straight and Narrow Path 592

20 a 12 A 24-POINT LATIN CONDENSED. \$3.50

BOSTON IMPORTATIONS

Childhood Vividly Recalled 46

12 a 8 A 36-POINT LATIN CONDENSED. \$4.25

FRENCH MENU

Denmark Societies 25

8 a 5 A 48-POINT LATIN CONDENSED. \$5.00

NORSEMEN ARE HISTORIC

First Discoverer of America 1492

60 a 30 A 8-POINT ANTIQUE No. 31. \$3.20

SAMPSON BOMBARDED SANTIAGO
The Vesuvius Dynamite Cruiser at Work 23

40 a 20 A 10-POINT ANTIQUE No. 31. \$3.20

BEST NEWSPAPER TYPE
For War News Scare Headings 45

30 a 15 A 12-POINT ANTIQUE No. 31. \$2.85

CUBANS VICTORIOUS
Dewey Made a Clean Sweep 6

25 a 12 A 18-POINT ANTIQUE No. 31. \$4.65

HERO HOBSON
Cervera Bottled up 7

20 a 10 A

24-POINT ANTIQUE No. 31.

\$6.75

UNITED FREEDOM
Downfall of Monarch Reigning

15 a 8 A

36-POINT ANTIQUE No. 31.

\$10.50

MINERS Bombarded

5 a 5 A

48-POINT ANTIQUE No. 31.

\$10.65

RICH Maidens

50 a 30 A 6-POINT MODERN ANTIQUE. \$2.20

BREATHING SWEET PERFUMES AMONG FLOWERS
Eagerly Searching for Something to Enhance Happiness 258

40 a 25 A 10-POINT MODERN ANTIQUE. \$2.70

PLANNING AND DESIGNING WORK
Type Implements Acquired Through Skill 29

25 a 15 A 18-POINT MODERN ANTIQUE. \$3.90

PERSONAL Thoughtfully 74

10 a 7 A 30-POINT MODERN ANTIQUE. \$5.00

MORE Pleased 37

8 a 6 A 36-POINT MODERN ANTIQUE. \$6.00

WORKMEN 95

8 a 6 A 42-POINT MODERN ANTIQUE. \$7.50

TROUBLES 37

8 a 5 A 48-POINT MODERN ANTIQUE. \$9.00

HOMES 82

40 a 25 A 8-POINT MODERN ANTIQUE. \$2.45

PRACTICAL KNOWLEDGE DESIDERATUM
Reinforced by New Theories Strengthened by 495

40 a 20 A 12-POINT MODERN ANTIQUE. \$3.30

WHERE PURITY GOODNESS
Furnishing Goods for Gentlemen 180

20 a 12 A 24-POINT MODERN ANTIQUE. \$4.50

MERINO SHIRTS
Desirable Rations 462

8 a 6 A 36-POINT MODERN ANTIQUE. \$6.00

Manufacturer

8 a 6 A 42-POINT MODERN ANTIQUE. \$7.50

Franklin

8 a 5 A 48-POINT MODERN ANTIQUE. \$9.00

Freedom

50 a 36 A 6-POINT CLARENDON. \$2.50

ELEGANT DIAMOND RING CHRISTMAS PRESENTS
Cabinets Holding Thirty-six Cases Economize Floor Space 23

40 a 24 A 10-POINT CLARENDON. \$3.05

EMBOSSING WITH CARDBOARD
See Our Brass Rule Specimen Pages 34

24 a 16 A 14-POINT CLARENDON. \$3.10

BUSINESS INCREASING
Estates Built and Managed 57

15 a 8 A 24-POINT CLARENDON. \$4.00

BRASS GAUGES
Preferred by Printer 1

6 a 5 A 36-POINT CLARENDON. \$6.00

OUR 4 Sauce

50 a 30 A 8-POINT CLARENDON. \$2.70

BONDED NEGOTIATIONS CONSIGNED
Heralded throughout the United Kingdom 35798

24 a 16 A 12-POINT CLARENDON. \$3.00

DIAMOND NICKED TYPE
Distinguishes Point System 9

18 a 12 A 18-POINT CLARENDON. \$3.25

ENGLISH SHIPPING
Sailing for Ensigns in 429

12 a 8 A 30-POINT CLARENDON. \$4.50

DIPLOMATIC
First Congress 34

5 a 3 A 48-POINT CLARENDON. \$7.00

ICE Man

30A \$1.50 60a \$1.00 6-Pt. Hansen Old Style No. 2 \$2.50

HANSEN'S TYPE IS DIAMOND NICK, AND CAN READILY BE DISTINGUISHED FROM ALL OTHERS

Be sure that all Leads and Slugs used in your office in the future, if not now, are manufactured by H. C. Hansen. Then you will have them of equal height, thickness and perfectly square, which saves you Time and Money. They are made of the best material and have no equal. You can obtain a pound or a ton, full length, or cut of any thickness, at short notice. Remember that they are made by H. C. Hansen, who has spent over 35 years making improved machinery which is not equalled in the world.

25A \$2.00 30a \$1.00 10-Pt. Hansen Old Style No. 2 \$3.00

BOOK, NEWSPAPER AND JOB TYPE

The secret why Type and other articles made at my Establishment are so far superior to all others is largely due to the fact that I have the best trained artisans, the very best machinery, and all work done is overseen by me personally in all the departments connected with the Type Foundry.

12A \$2.25 20a \$1.75

18-Pt. Hansen Old Style No. 2

\$4.00

HAMILTON WOOD FURNITURE OF ALL KINDS

Metal Furniture and Quotations are finished to justify accurately with Point Standard Type, made by H. C. Hansen, Type Founder

25A \$1.60 35a \$1.15 8-Pt. Hansen Old Style No. 2 \$2.75

**METAL FURNITURE AND QUOTATIONS
QUADS AND SPACES, GUARD LINES, FIGURES**

Quads and Spaces without nicks have proved to be of great advantage to Printers, and as I make them square on the ends, the different sizes can be more easily discerned. Guard Lines are shaved to 18-Point body, and planed to type-high.
1234567890

18A \$1.90 30a \$1.35 12-Pt. Hansen Old Style No. 2 \$3.25

NEW BRASS ROUND CORNERS

For various jobs the printer requires round corners to suit the work in hand. A complete assortment will be found at 190-192 Congress Street, Boston, where all orders will be attended to at very short notice.

10A 16a 18-Pt. Congress

When the dews of night have fallen,
 And the stars fond vigil keep,
 When the cares of day are over,
 And the world is hushed in sleep.

\$4.00

6A 10 a

24-Pt. Congress

\$4.50

The G. A. R. Encampment at Washington in 1902

5A 2a

30-Pt. Congress

\$4.75

Music for Grand Opera composed by Rolfe

4A 8a

36-Pt. Congress

\$6.00

Cylinder Press Chases in various sizes

4A 6a

42-Pt. Congress

\$6.25

Hansen's Quads without Nicks

3A 5a

49-Pt. Congress

\$6.50

Hamilton Wood Furniture

Hamilton Wood Furniture

This Series lines accurately at the bottom. Use Point System leads and slugs in justifying

42 Point, Initial font, \$2 00 15 cents per letter

A B C D E F G H I J K
L M N O P Q R S
T U V W X Y Z

18 Point Initial font, \$1 00 10 cents per letter
30 Point Initial font, 1 50 15 cents per letter
48 Point Initial font, 2 50 20 cents per letter

24 Point Initial font, 1 25 10 cents per letter
36 Point Initial font, 1 75 15 cents per letter
Capitals put up in fonts of 30 letters each

10A 16a

18-PT. COMMONWEALTH

\$3.25

Engraving and Casting Type through skilled labor
12345 Solid Brass Gauges 67890

8A 10a

24-PT. COMMONWEALTH

\$4.25

Specialties in Brass Rules from original
Designs by H. C. Hansen 1250

5A 8a

36-PT. COMMONWEALTH

\$6.20

Anxious for future prosperity
and success 1234567890

4A 6a

42-PT. COMMONWEALTH

\$7.00

Ornamental and Useful 5

4A 5a

48-PT. COMMONWEALTH

\$7.75

**Dust Proof Cabinet 7
Type held firm 123**

4A 3a

54-PT. COMMONWEALTH

\$8.75

**Metal Furniture &
labor-saving rule**

mmmmmmmmmm

This Series lines accurately at the bottom. Use Point System leads and slugs in justifying

POSTER BUFFALO

25 Pounds and over

6 Point

\$1 16 per lb.

PRICES ARE FIXED with mathematical precision by supply and demand. *The* world's selling prices are regulated by market and crop reports. We travel greater distances in a shorter space of time and with more ease than was ever dreamed of by the fathers. Isolation is no longer possible or desirable. *The* same important news is read, though in different languages, the same day in all Christendom. *The* telegraph keeps us advised of what is occurring everywhere, and the press foreshadows, with more or less accuracy, the plans and purposes of the nations. Market prices of products and of securities are hourly known in every commercial market, and the investments of the people extend beyond their own national boundaries into the remotest parts of the earth. Vast transactions are conducted and international exchanges are made by the tick of the cable. Every event of interest is immediately bulletined and the quick gath-

25 Pounds and over

8 Point

90c. per lb.

PRICES are fixed with mathematical precision by supply and demand. The world's selling prices are regulated by the market and crop reports. We travel greater distances in shorter space of time and with more ease than was ever dreamed of by the fathers. Isolation is no longer possible or desirable. *The* same important news is read, though in different languages the same day in all Christendom. The telegraph keeps us advised of what is occurring everywhere, and the press foreshadows, with more or less accuracy, the plans and purposes of the nations. Market prices of products and

1234567890

25 Pounds and over

10 Point

74c. per lb.

PRICES are fixed with mathematical precision by supply and demand. *The* world's selling prices are regulated by the market and crop reports. We travel greater distances in a shorter space of time and with more ease than was ever dreamed of by the fathers. Isolation is no longer possible or desirable. The same important news is read, though in different languages, the same day in

25 Pounds and over

12 Point

66c. per lb.

PRICES are fixed with mathematical precision by supply and demand, The world's selling prices are regulated by market and crop reports. We travel a greater distance and in shorter space of time, and with more ease than was ever dreamed of by the fathers. Isolation is no

The of 4683 & 3

POSTER BUFFALO

25 Pounds and over

14 Point

62c. per lb.

PRICES ARE FIXED with mathematical precision by supply and demand. *The* world's selling prices are regulated by market and crop reports. We can travel a greater distance and in shorter space of time and with more ease than was dreamed of by the fathers. Isolation is no longer possible or desirable. Important news is read all over the world, though in different languages, the same day in all Christendom. A cable keeps us advised of what is occurring, and the

25 Pounds and over

18 Point

60c. per lb.

PRICES are fixed with mathematical precision by the supply and demand. The world's selling prices are regulated by market and crop reports. We travel a greater distance in a shorter space of time and with more ease than was dreamed of by the fathers. The same important and

POSTER BUFFALO

25 Pounds and over

24-Point

56c. per lb.

PRICES ARE fixed with mathematical precision by supply and demand. *The* world's selling prices are regulated by market and crop reports. We travel greater

25 Pounds and over

30-Point

56c. per lb.

PRICES ARE fixed with mathematical precision by supply and demand. Isolation is no longer possible or

POSTER BUFFALO OUTLINE

25 Pounds and over

12 Point

66c. per lb.

IF PERCHANCE some of our tariffs are no longer needed for revenue or to encourage our industries at home, why should they not be employed to extend and promote our many markets abroad? Then, too, we have inadequate Steamship Services. New lines of steamers are put in commission between Pacific coast ports of the United States and those on the western coast of Mexico and South and Central America. These should be followed up with direct steamship lines between the eastern coast of the United States and South American ports. One of the needs of the times is direct commercial lines from our vast fields of production to the co-

25 Pounds and over

14-Point

62c. per lb.

IF perchance some of our tariffs are no longer needed for revenue or to encourage and protect our industries at home, why not be employed to extend and promote our markets in the foreign countries? Lines of steamers have been put in commission between Pacific coast ports of the United States and those on western coast of Mexico and South and Central America. They should be followed up with direct steamship lines from the eastern coast of United States and South American

POSTER BUFFALO OUTLINE

25 Pounds and over

18-Point

60c. per lb.

IF perchance some of our tariffs are no longer needed for revenue or to encourage and protect our industries at home, why should they not be employed to extend our market abroad? Then, too, we have an inadequate steamship service. New lines of steamers

25 Pounds and over

24-Point

56c. per lb.

IF perchance some of our tariffs are no longer needed for revenue or to encourage and protect industries at home why should they not be employed to extend and finish

POSTER BUFFALO OUTLINE

25 Pounds and over

30-Point

56c. per lb.

IF perchance some of our tariffs are no longer needed for revenue, encourage and protect our industries

50 Pounds and over

36 Point

56c. per lb.

IF perchance some of our tariffs are no longer needed to promote

POSTER DE VINNE

25 pounds and over

6-Point

\$1.16 per lb

TRADE statistics indicate that this country is in a state of unexampled prosperity. The figures are almost appalling. They show that we are utilizing our fields and forests and mines and that we are furnishing profitable employment to the millions of our workingmen throughout the United States, bringing comfort and happiness to their homes and making it possible to lay by savings for old age and disability. That all the people are participating in this great prosperity is seen in every American community and is shown by the enormous and unprecedented deposits in our savings banks. Our duty is the care and security of these deposits, and their safe investment demands the highest integrity and the best business capacity of those in charge of these depositories of the people's earnings. We have a vast and intricate business, built up through years of toil and struggle, in which every part of the country has its stake, which will not permit of either neglect, or of undue

25 pounds and over

8-Point

90c. per lb.

TRADE statistics indicate that this country is in a state of unexampled prosperity. The figures are almost appalling. They show that we are utilizing our fields and forests and mines, and that we are furnishing profitable employment to the millions of our workingmen throughout the United States, bringing comfort and happiness to their homes and making it possible to lay by savings for old age and disability. That all the people are participating in this great prosperity is seen in every American community and shown by the enormous and unprecedented deposits in our savings banks. Our duty is the care and security of these deposits, and their investments

25 pounds and over

10-Point

74c. per lb.

Trade statistics indicate that this country is in a state of unexampled prosperity.* The figures are almost appalling. They show that we are utilizing our fields and forests and mines and that we are furnishing profitable employment to the millions of our workingmen throughout the United States, bringing comfort and happiness to their homes and making it possible to lay by savings for old age and disability. All the people are participating in this great**

25 pounds and over

12-Point

66c. per lb.

TRADE statistics indicate that this country is in a state of unexampled prosperity. The figures are almost appalling. They show that we are utilizing our fields and forests and mines and that we are furnishing profitable employment to millions of workingmen throughout United States, bringing comfort and happiness.

POSTER DE VINNE

25 Pounds and over

14-Point

62c. per lb.

Trade statistics indicate that this country is in a state of unexampled prosperity. The figures are almost appalling. They show that we are utilizing our fields and forests and mines and that we are furnishing profitable employment to millions of workers

25 Pounds and over

18-Point

60c. per lb.

Trade statistics indicate that this country is in a state of unexampled prosperity. The figures are almost appalling. They show that we are furnishing a profitable

25 Pounds and over

24-Point

56c. per lb.

TRADE statistics indicate that this country is in a state of unexampled prosperity. The figures are almost appalling, it shows that we are in a position to furnish everything. 123

POSTER DE VINNE

25 Pounds and over

30-Point

56c. per lb.

BE SURE that all Leads and Slugs used in your office in the future, if not now, are manufactured by H. C. Hansen, Type Founder, 190-192 Congress St.

50 Pounds and over

36-Point

96c. per lb.

THEN you will always have them equal height and thickness, also perfectly square and smooth

POSTER DE VINNE CONDENSED

25 pounds and over

6-Point

\$1 16 per lb

COMPARISON OF IDEAS IS ALWAYS EDUCATIONAL; and as such instructs the brain and hand of man. Friendly rivalry follows, which is the spur to industrial improvement, the inspiration to useful invention and to high endeavor in all departments of human activity. It exacts a study of the wants, comforts, and even the whims of the people, and recognizes the efficacy of high quality and new prices to win their favor. The quest for trade is an incentive to men of business to devise, invent, improve, and economize in the cost of production. Business life, whether among ourselves or with other peoples, is ever a sharp struggle for success, and it will be none the less so in the future. Without competition we should be clinging to the clumsy and antiquated processes of farming and manufacture and the methods of business of long ago, and the twentieth would be no further advanced than the eighteenth century. But though commercial competitors we are, commercial enemies we must not be. This portion of the earth has no cause for humiliation for the part it has performed in the march of civilization; it has not accomplished everything; far from it. It has simply done its best, and without vanity or boastfulness, and recognizing the manifold achieve-

25 pounds and over

8-Point

90c. per lb.

COMPARISON of ideas is always educational; and as such instructs the brain and hand of man. Friendly rivalry follows, which is the spur to industrial improvement, the inspiration to useful invention and to high endeavor in all departments of human activity. It exacts a study of the wants, comforts, and even the whims of the people, and recognizes the efficacy of high quality and new prices to win their favor. The quest for trade is an incentive to men of business to devise, invent, improve, and economize in the cost of production. Business life, whether among ourselves or with other peoples, is ever a sharp struggle for success, and it will be none the less so in the future. Without competition we should be clinging to the clumsy and antiquated processes of farming and manufacture and the methods of business of long ago, and the twentieth would be no further advanced than the eighteenth century, but com-

25 pounds and over

10-Point

74c. per lb.

COMPARISON of ideas is always educational; and as such instructs the brain and hand of man. Friendly rivalry follows, which is the spur to industrial improvement, the inspiration to useful invention and to high endeavor in all departments of human activity. It exacts a study of the wants, comforts, and even the whims of the people, and recognizes the efficacy of high quality and new prices to win their favor. Quest for trade is an incentive to men of business to devise, invent, improve, and economize in the cost of production. Business life, whether among ourselves or with other peoples, is ever

25 pounds and over

12-Point

66c. per lb.

COMPARISON of ideas is always educational; and as such instructs the brain and hand of man. Friendly rivalry follows, which is the spur to industrial improvement, the inspiration to useful invention and high endeavor in all departments of human activity. It exacts a study of the wants and comforts and even the whims of the people, and recognizes the efficacy of high quality and new prices to win their favor. The quest for

POSTER DE VINNE CONDENSED

25 pounds and over

14-Point

62c. per lb.

COMPARISON of ideas is always educational; and as such instructs the brain and hand of man. Friendly rivalry follows, which is the spur to industrial improvement, the inspiration to useful invention and to high endeavor in all departments of human activity. It exacts a study of the wants and even whims of people, and recognizes efficacy the high

25 pounds and over

18-Point

60c. per lb.

COMPARISON of ideas is always educational; and as such instructs the brain and hand of man. Friendly rivalry follows, which is the spur to industrial improvement, the inspiration to useful invention and to highest

25 pounds and over

24-Point

56c. per lb.

COMPARISON of ideas is always educational; and as such instructs the brain and hand of man. Friendly rivalry follows, which is the spur to industrial improvements, the inspiration to useful

POSTER DE VINNE CONDENSED

25 pounds and over

30-Point

56c. per lb.

**Comparison of ideas is always educa-
tional; and such instructs the brain,
making improvement in every thought**

50 pounds and over

36-Point

56c. per lb.

**Comparison of ideas is always
educational; and such instructs
the brain, and improvement in**

«HHHHHHHHHHHHHHHHHH»

This Series lines at the bottom. Use point leads and Slugs in justifying.

POSTER STRATFORD OLD STYLE

25 Pounds and over 6-Pt. Stratford Old Style \$1.16 per lb.

SYSTEMS WHICH PROVIDE A MUTUAL EXCHANGE OF commodities is manifestly essential to the continued and healthful growth of our export trade. We must not repose in fancied security that we can forever sell everything and buy nothing. If such a thing were possible it would not be best for us or those with whom we deal. We should take from our customers such of their products as we can use without harm to our industries and labor. Reciprocity is the natural outgrowth of our wonderful industrial development under the domestic policy now firmly established. What we produce beyond our domestic consumption must have vent abroad.

☞ The excess must be relieved through a foreign outlet, and we should sell anywhere we can and buy wherever the buying will enlarge our sales and productions and thereby make a greater demand for home labor. The period of exclusiveness is past. The expansion of our trade and commerce is the pressing problem. Commercial wars are unprofitable. A policy of good will and friendly

25 Pounds and over 10-Pt. Stratford Old Style 74c. per lb.

SYSTEMS WHICH PROVIDE MUTUAL exchange of commodities is manifestly essential to continued and healthful growth of our export trade. We must not repose in security that we can forever sell everything and buy little or nothing. If such a thing were possible it would not be best for us. ☞ We should take from our customers such of their productions as we can use without harm to our industries and to labor. Reciprocity is the natural outgrowth of wonderful industrial development under the domestic

25 Pounds and over 8-Pt. Stratford Old Style 90c. per lb.

☞ **SYSTEMS WHICH PROVIDE A MUTUAL** exchange of commodities is manifestly essential to the continued and to healthful growth of our export trade. We must not repose in fancied security that we can forever sell everything and buy little or nothing. If such a thing were possible it would not be best for us or those with whom we deal. We should take from our customers such of their products as we can use without harm to our industries and labor. Reciprocity is the natural outgrowth of our wonderful industrial development under the domestic policy now firmly established. What we produce beyond our domestic consumption must have a vent abroad. The excess must have a

25 Pounds and over 12-Pt. Stratford Old Style 66c. per lb.

SYSTEMS which provide a mutual exchange of commodities is manifestly essential to the continued and healthful growth of our export trade. We must not repose in fancied security that we can forever sell everything and buy little or nothing. If such things were possible it were not best for us or those with whom we deal. What we produce beyond

POSTER STRATFORD OLD STYLE

25 Pounds and over

18-Pt. Stratford Old Style

60c per lb.

QSYSTEMS which produce a mutual exchange of commodities is manifestly essential to the continued and healthful growth of our export trade. We must not repose in a fancied security that we can forever sell everything and buy little or nothing. If such a thing were possible it would not be the best for us or

25 Pounds and over

24-Pt. Stratford Old Style

56c. per lb.

QSYSTEMS which provide a mutual exchange of commodities is manifestly essential to the continued and healthful growth of our export trade. We must not repose in fancied security that we can forever sell any-

POSTER STRATFORD OLD STYLE

25 Pounds and over

30-Pt. Stratford Old Style

56c. per lb.

SYSTEMS which provide the mutual exchange of commodities are manifestly essential for

50 Pounds and over

36-Pt. Stratford Old Style

56c. per lb.

Q Systems which provide mutual exchange of commodities is manifestly 24

HANSEN'S PARAGRAPH MARKS.

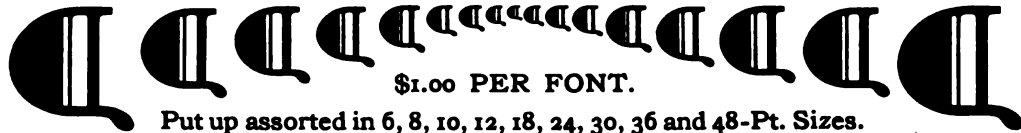

POSTER ANTIQUE No. 31

25 pounds and over 8 Point 90c. per lb.

NEXT IN ADVANTAGE TO having the thing to sell is to have the convenience to carry it to the buyer. We must encourage our merchant marine. We must have many more ships. They must be under the American flag, built and manned and owned by Americans. The construction of a Pacific cable cannot longer be postponed. In the furtherance of these objects of national interest you are performing an important part. If the people will do their part, all the other work will come in good time. Who can tell the thoughts, the ambitions,

25 pounds and over

25 pounds and over 10 Point 74c. per lb.

NEXT in advantage to having the thing to sell is to have the convenience to carry it to the buyer. We must have more ships. They must be under the American flag, built and manned and owned by Americans. The construction of a Pacific cable cannot be later postponed. In furtherance of these objects of a national interest you are performing important and best

18 Point

25 pounds and over 12 Point 66c. per lb.

NEXT in advantage to having the thing to sell is to have the convenience to carry it to the buyer. In the furtherance and continuance of this object of national interest you are doing an important share of the work on hand. These will not only be profitable to you, but to the buyers of

60c. per lb.

NEXT in advantage to having the thing to sell is to have the convenience to carry it to the buyer. We must encourage our merchant marine. We must have more ships,

POSTER ANTIQUE No. 31

25 pounds and over

24 Point

56c. per lb.

NEXT in advantage to having the thing to sell is to have the convenience to carry it to the buyer. We must encourage our merchant marine and we must

50 pounds and over

36 Point

56c. per lb.

NEXT in Advantage to having the thing to sell is to have conven-

POSTER LATIN ANTIQUE

25 pounds and over 6-Point \$1.16 per pound

The next annual meeting of the United Typothetæ will be held in Buffalo, the last week in August. As the Pan-American Exposition, to be in progress at that time, will make it difficult for visitors to secure quarters in Buffalo unless arrangements are made in advance, all local organizations are requested to send to the secretary of Buffalo Typothetæ as early as possible the lists of delegates and number of members that will probably attend. Every effort will be made to look after all who decide to go. There is no question as to the advantage of visiting Buffalo at that time, as those interested in the graphic arts are aware.

25 pounds and over 8-Point 90c. per pound

The next annual meeting of the United Typothetæ will be held in Buffalo, the last week in August. As the Pan-American Exposition, to be in progress at that time, will make it difficult for visitors to secure quarters in Buffalo unless arrangements are made in advance, all local organizations are requested to send to the secretary of Buffalo Typothetæ as early as possible the lists of delegates and number of members that will probably attend. Every effort will be made to look after all who

25 pounds and over 10-Point 74c. per pound

The next annual meeting of the United Typothetæ will be held in Buffalo, the last week in August. As the Pan-American Exposition, to be in progress at that time, will make it difficult for visitors to secure quarters in Buffalo unless arrangements are made in advance, all local organizations are requested to send to the secretary of Buffalo

25 pounds and over 12-Point 66c. per pound

The next annual meeting of the United Typothetæ will be held in Buffalo, the last week in August. As the Pan-American Exposition, to be in progress at that time, will make it difficult for visitors to secure quarters in Buffalo unless arrangements are made in advance, all local

POSTER LATIN ANTIQUE

25 pounds and over

18-Point

60c. per pound

THE next annual meeting of the United Typothetæ to be held in BUFFALO, the last week in August. As the Pan-American Exposition, to be in pro-

25 pounds and over

24-Point

56c. per pound

There is nothing like the sunshine in April; we fail to see the shine but would like to see everybody happy

25 pounds and over

30-Point

56c. per pound

Happy days with us once more, and all were rushing

50 pounds and over

36-Point

56c. per pound

Do not wait for things to turn up, try for yourself

POSTER HANSEN OLD STYLE

25 pounds and over 6-POINT \$1.16 per pound

TELEGRAPHING TO MARS WITHOUT WIRES

The latest achievements in electrical science makes it possible to send messages from one part of the earth to another through the medium of the electrical wave without wires. In the near future it is predicted that the Niagara falls will be harnessed to produce a sufficient power to meet the requirements of man throughout the civilized world, and there can be no doubt that the close of the present century will be an era in the progress of electrical science in the direction of producing unlimited power from nature itself and a means of communication between the old and the new world of unbounded value to the advancement of commerce and kindred industries now depending upon more primitive modes of

25 pounds and over 8-POINT 90c. per pound

IMPROVED TYPE CASTING MACHINERY

One of the busiest places in Washington, if not in the entire country, is the printing office of the Government. It is a veritable buzzing hive of industry. During the course of the year the amount of matter turned out of this huge place is tremendous, and fully explains why the office is so constantly busy. The year 1897 was a particularly busy one; in the course of the year the office shipped 318,866 public documents, or 1,045 each day. Of the documents turned

25 pounds and over 10-POINT 74c. per pound

HISTORY OF EARLY PRINTING

There is a wide spread belief that typography was, in all its details, a purely original invention. A very popular version of its origin says it was the result of an accidental discovery; a conflicting version says that it was the result of more than eleven years of experiment. Each version teaches us that there was no perceptible

25 pounds and over 12-POINT 66c. per pound

CABINETS AND STANDS

Printing is the art of producing impressions from characters or figures, on paper, cloth, or other substances. There are several very distinct branches of this important art: as the printing of books with movable types, the printing of engraved copper and steel plates, and the taking of impressions from stone, called lithographing. The printing of books or sheets with movable types, generally called letter press

25 pounds and over 14-POINT 62c. per pound

MANUFACTURERS

The poetical temperament shown in the character of Columbus, seen throughout all his writings, and in all his actions, spread a golden and glorious world about him, and it tinges everything with its gorgeous colors, betraying him with visions

POSTER HANSEN OLD STYLE

25 pounds and over

18-POINT

60c. per pound

ANTIQUARIANS

Many distinguished scientists versed in Egyptian mythology believe the fabulous doctrines respecting heathen deities to be without foundation, and they are now led to believe that the manuscripts found in tombs

25 pounds and over

30-POINT

56c. per pound

GOOD MUSIC
Beethoven was one of the great music composers of olden

50 pounds and over

36-POINT

50c. per pound

SUNSHINE

Klondike is the land of promise for gold seekers

25 pounds and over

24-POINT

56c. per pound

POSTER TYPE

Popular type faces for unique poster printing in large fonts suitable for all kinds of display

POSTER HANSEN OLD STYLE No. 2

25 Pounds and over

6 Point

\$1.16 per lb.

TRADE statistics indicate that this country is in a state of unexampled prosperity. The figures are almost appalling. They show that we are utilizing our fields and forests and mines and that we are furnishing profitable employment to the millions of our workmen throughout the United States, bringing comfort and happiness to their homes and making it possible to lay by savings for old age and disability. That all the people are participating in this great prosperity is seen in every American community and shown by the enormous and unprecedented deposits in our savings banks. Our duty is the care and security of these deposits, and their safe investment demands the highest integrity and the best business capacity of those in charge of these depositories of the people's earnings. We have a vast and intricate business, built up through years of toil and struggle, in which every part of the country has its stake, which will not permit of neglect or of undue selfishness. No narrow, sordid policy will subserve it. The greatest skill and wisdom on the part of manufacturers and producers

25 Pounds and over

8 Point

90c. per lb.

TRADE statistics indicate that this country is in a state of unexampled prosperity. The figures are almost appalling. They show that we are utilizing our fields and forests and mines and that we are furnishing profitable employment to the millions of workmen throughout the United States, bringing comfort and happiness to their homes and making it possible to lay by savings for old age and disability. That all the people are participating in this great prosperity is seen in every American community and shown by the enormous and unprecedented deposits in our savings banks. Our duty is the care and security of these deposits, and their safe investment demands the highest integrity and best business capacity of those in charge

25 Pounds and over

10 Point

74c. per lb.



WHEN you can obtain a pound or a ton of Leads or Slugs, full length or cut to any thickness, at short notice, remember that they are made at 190-192 CONGRESS ST., by H. C. HANSEN, Type Founder, who has spent over TWENTY-FIVE years making improved machinery which are not equalled anywhere in the world. There are individual consumers who have used at least 50,000 pounds of H. C. Hansen's leads. Write for prices, they are no higher than the inferior article. Then you will always have them of equal height, thickness and perfectly square, which saves you time and money. They are made of the best material and have no equal. A complete printing office can be furnished at the shortest possible notice, including Presses, Paper Cutters, Inks, Imposing Stones, Hamilton Wood Goods, Frames, Stands, Racks, Cases, Type, Leads, Slugs, Quotations, Metal Furniture, Spaces, Quads, Brass Rules Circles, Ovals, Round Brass Corners, Cutting Rule, Perforating Rule, Mitering Machines, Lead Cutters, Composing Sticks, Benzine Cans, and in fact everything from Machinery to a Bodkin.

POSTER HANSEN OLD STYLE, No. 2

25 Pounds and over

12 Point

66c. per lb.

TRADE STATISTICS indicate that this country is in a state of unexampled prosperity. The figures are almost appalling. They show that we are utilizing our fields and forests and mines, and that we are furnishing profitable employment to the millions of our workmen throughout the United States, bringing comfort and happiness to their homes, and making it possible to lay by savings for old age and disability. That all the people are participating in this prosperity is seen in every American community and shown by the enormous and unprecedented deposits in our savings banks. Our duty is the care and security of these deposits, and their Safe Investment demands the highest integrity and the best business capacity of those in charge of these depositories of the people's earn-

25 Pounds and over

18 Point

60c. per lb.

TRADE statistics indicate that this country is in a state of unexampled prosperity. The figures are almost appalling. They show that we are utilizing our fields and forests and mines, and that we are furnishing profitable employment to the millions of workmen throughout the United States, bringing comfort and happiness to their homes and making it possible to lay by savings for old age and disa-

BARRISTER ITALIC

80a 28A

6-PT. BARRISTER ITALIC

\$3.50

*TYPE MADE FOR ALL KINDS OF WORK FROM A
HAIR LINE TO A HEAVY GOTHIC*

The new faces added to this Specimen book are made from Hard and Extra Tough Metal, therefore Hansen's type will give the best satisfaction to all purchasers.

LOOK FOR SPECIMENS FROM 190-192 CONGRESS STREET, BOSTON, MASS.

In looking up law blanks for reference you will find the same style in all preambles similar to this type. It is made expressly for this branch of business and is used throughout the United States in regard to law and the findings thereof. To all whom it may concern, viz. etc.

70a 24A

8-PT. BARRISTER ITALIC

\$3.70

*ALL QUADS CAST IN THIS FOUNDRY
ARE MADE WITHOUT NICKS*

All type made here is cast with Diamond nicks, and is readily distinguished from all others. H. C. Hansen is a complete printing office furnisher, and all orders receive prompt and careful attention. When purchasing, call and be convinced of his square dealing, absolute reliability and prompt attention to all orders entrusted to him. No order too large none too small for his pers-

50a 20A

10-PT. BARRISTER ITALIC

\$3.60

*INSOLVENCY COURT
SUFFOLK, S.S. MASSACHUSETTS*

The creditors of John P. Munion Co. will hold their first meeting on Tuesday afternoon at three o'clock, in the Board of Trade office, to consider the proposed settlement of thirty-five cts. on the dollar, with other propositions.

40a 12A

12-PT. BARRISTER ITALIC

\$3.50

*BUSINESS TRANSACTION
vs.
STORAGE WAREHOUSE CO.*

To have and to hold the right of way for all teams through said passage for delivery of goods for shipment to foreign ports and all return thereof through the same.

Card Text Series

Miss Alice Atherton

*Four Sizes,
8, 10, 12 and 18-Pt.*

*Bostonian
Opera Company*

Mr. & Mrs. Otto Baldwin

Married

Thursday Evening, June Seventeenth,

at

Bunker Hill Advent Church,

1902.

12A 36a 8-Pt. Card Text \$2.25
The Fuller color effect in Type

10A 30a 10-Pt. Card Text \$2.50
Reception at eight-thirty

9A 27a 12-Pt. Card Text \$2.75
Visiting or Addresses

6A 18a 18-Pt. Card Text \$3.25
Concert at eight

Half-tone Process Co.

*Liberty Building,
Boston.*

25A 6-Point Card Roman No. 32 \$1.00

IF YOU WISH TO PURCHASE HARD AND EXTRA TOUGH METAL TYPE, YOU WILL FIND IT WEAR LONGER FOR FINE WORK AND WITH A BETTER RESULT. GIVE H. C. HANSEN'S TYPE A FAIR TRIAL AND YOU WILL BE CONVINCED OF THE SUPERIORITY OF HIS METAL. IT IS ALLOYED WITH COPPER, TIN AND ANTIMONY. 128486769

20A 6-Point Card Roman No. 33 \$1.00

THIS CARD ROMAN IS VERY FINE FOR CARDS, CIRCULARS, AND ALL SMALL WORK IN PRINTING LINE BEING ADAPTED TO LIGHT WORK IT MAKES A FINE APPEARANCE. MADE BY H. C. HANSEN, BOSTON.

18A 6-Point Card Roman No. 34 \$1.15

THE COMPLETE PRINTING OFFICE FURNISHER AT 190-192 CONGRESS ST., BOSTON. LEAVE YOUR ORDER FOR A JOHN THOMSON EMBOSSENG AND PRINTING PRESS. CYLINDER DISTRIBUTION. 1234

18A 8-Point Card Roman No. 35 \$1.55

PRESSES AND PAPER CUTTERS. MITERING MACHINES, PRINTING MATERIAL OF EVERY DESCRIPTION FOR A COMPLETE OUTFIT. 6

15A 10-Point Card Roman No. 36 \$1.75

THE LEADS AND SLUGS OF MY MANUFACTURE ARE SUPERIOR TO ALL OTHER MAKES. 12345687

12A 12-Point Card Roman No. 37 \$2.00

CASES, STANDS, FRAMES, RACKS, CABINETS, ETC. 25

8A 18-Point Card Roman No. 38 \$2.50

PUBLIC GARDEN, PICTURESQUE 25

6A 24-Point Card Roman No. 39 \$2.75

HANSEN'S ROMAN IS 39

•HHHHHHHHHHHH•

E. W. POWER
E. S. LIGHT

POWER AND LIGHT

ELECTRIC MOTORS
FOR SALE

TELEPHONE 2738

R. U. A. PERFORATOR COMPANY

H. C. HANSEN

MANUFACTURER OF

TYPE

190-192 CONGRESS ST.,

BOSTON

PIN-HOLE MACHINES

PADDLE YOUR OWN
CANOE

CHARLES RIVER CANOE
....CLUB....

ANY DAY DURING THE SEASON

BRING A FRIEND

HEADQUARTERS
FOR TYPE

TYPE MANUFACTURER

STITCHING MACHINES

CARD GOTHIC

22A 6-Pt. No. 10 \$1 00

THE MAKING OF GOOD AND UPRIGHT YOUTH
IN A BIG CITY OF 574,000,000 POPULATION.

20A 6-Pt. No. 11 \$1 00

WHEN MARINERS SAIL OLD OCEAN
FOR FOREIGN CLIMES & \$ £ 2345

18A 6-Pt. No. 12 \$1 00

THE MERRY MAIDEN AND
HER FUNNY CHARACTERS

16A 8-Pt. No. 13 \$1 00

CHRISTMAS PLAYS

14A 8-Pt. No. 14 \$1 15

TYPE FOUNDER

12A 10-Pt. No. 15 \$1 25

CARD GOTHIC

10A 12-Pt. No. 16 \$1 50

BOOTS AND

TYPE,
BORDERS,
LEADS,
SLUGS AND
BRASS
RULES

TYPE	IS ALLOYED WITH	TYPE
	COPPER, TIN	
	AND ANTIMONY.	
TYPE		TYPE

MME. D'RAJANURE,
FRENCH MILLINER.

415 BOYLSTON ST.,

FALL OPENING,
THURSDAY.

BOSTON.

CARD GOTHIC

E. MOLLEHAUER,
CONDUCTOR.

CHAS. BRAINARD DAVIES.

MUSICAL
PRODUCTIONS.

SCULPTOR.

THE ESSEX BANK,

CAPITAL, \$5,750,000

93 ARGYLE PARK,
LONDON, E. C.

MINNIE MADDERN FISKE,
ARTIST.

CHARLES HABERSTRAW,
DECORATOR.

WITH
FROHAM'S CO.

MILK ST.

CHICAGO.

PLATE ROMAN

25A 6-Point Plate Roman No. 1 \$1.00

FINEST SERIES OF ENGRAVER'S ART
NEW FACES ARE CONSTANTLY BEING MADE IN THIS ESTABLISHMENT
UNDER THE DIRECTION OF H. C. HANSEN, TYPE FOUNDER, BOSTON MASS

20A 6-Point Plate Roman No. 3 \$1.00

THE NEW FLYING MACHINE IN BOSTON
EXHIBITION ON BOSTON COMMON, JUNE 17TH, 1903
WITH PARACHUTE ATTACHMENTS

16A 12-Point Plate Roman No. 5 \$1.50

LEADING TYPE FACES
MADE AT HANSEN TYPE FOUNDRY

12A 12-Point Plate Roman No. 7 \$1.50

ENTHUSIASTIC
MANY NEW FACES MADE

8A 18-Point Plate Roman No. 9 \$2.00

THE MODERN
INVENTIONS AND

5A 24-Point Plate Roman No. 11

ANGLES ACCURATELY 1

22A 6-Point Plate Roman No. 2 \$1.00

SPECIAL RULES MADE TO ORDER
H. C. HANSEN MAKES SPECIAL RULES FROM ANY DESIGN
THAT MAY BE FURNISHED. ORDERS PROMPTLY DELIVERED

16A 6-Point Plate Roman No. 4 \$1.00

EVERYTHING MADE BY H. C. HANSEN
IS UNDER ONE ROOF, CONGRESS STREET.
COVERING EIGHTEEN THOUSAND

16A 12-Point Plate Roman No. 6 \$1.50

MANY DEVICES
USED BY LEADING PRINTERS 8

10A 12-Point Plate Roman No. 8 \$1.50

MACHINES
MADE AT HANSEN'S

7A 18-Point Plate Roman No. 10 \$2.00

VARIOUS
MACHINERY 45

CARD GOTHIC NO. 2

22A 6-Point Card Gothic No. 2 A \$1.00

A SERIES OF CARD GOTHIC MADE BY H. C. HANSEN AT 190-192 CONGRESS STREET, BOSTON, MASS. TAKE NOTICE TO THE LINING SYSTEM. JUSTIFY WITH POINT LEADS AND SLUGS. 123456

22A 6-Point Card Gothic No. 2 B \$1.00

ALL LEADS AND SLUGS ARE MANUFACTURED BY H. C. HANSEN FROM 16 TO PICA TO 1 INCH IN THICKNESS. THEY HAVE NO EQUAL. PRINTERS PROFIT BY USING HANSEN'S MANUFACTURES. THEY ARE FIRST IN QUALITY, ACCURACY & PROMPT DELIVERY

18A 6-Point Card Gothic No. 2 C \$1.00

COMPLETE PRINTING OFFICE FURNISHER 190-192 CONGRESS STREET. EVERYTHING TO FIT A PRINTER IN SHORT ORDER AND WITH DESPATCH LEADS, SLUGS, CABINETS, QUADS, INKS, & 26

16A 6-Point Card Gothic No. 2 D \$1.00

SORTS FURNISHED AT ONCE CALL AT H. C. HANSEN'S AND LOOK AT THE TYPE FOUNDRY 1234567890

15A 12-Point Card Gothic No. 2 A \$1.50

LEADING WOOD FURNITURE FOR SALE AT THIS TYPE FOUNDRY INCLUDING VARIOUS STYLE

14A 12-Point Card Gothic No. 2 B \$1.50

NEW IMPROVEMENTS MANY NEW DEVICES WITH UP-TO-DATE MACHINERY 12

12A 12-Point Card Gothic No. 2 C \$1.50

SPECIMEN OF TYPE MADE BY H. C. HANSEN TYPE FOUNDER

10A 12-Point Card Gothic No. 2 D \$1.50

CARD GOTHIC, 2 NEW COMBINATION FOR LIGHT WORK. 1



This Series lines accurately at the bottom. Use point leads in justifying

CARD GOTHIC No. 3.

Made in 8 sizes. See cards for two smallest sizes.

20A 6-Point Card Gothic No. 3 C \$1.00

**PRODUCTIONS ARE INCREASING RAPIDLY
ORDERS RECEIVE PROMPT AND CAREFUL ATTENTION**

16A 6-Point Card Gothic No. 3 D \$1.00

**MANY NEW TYPE FACES FOR PRINTERS
ARE TO BE SEEN IN THIS SPECIMEN BOOK OF 1903**

16A 8-Point Card Gothic No. 3 E \$1.15

**THE LATEST IMPROVEMENTS
190 H. C. HANSEN'S TYPE FOUNDRY. 192**

15A 8-Point Card Gothic No. 3 F \$1.25

**FOR IMMEDIATE USE
GOTHIC MADE AT H. C. HANSEN'S**

15A 10-Point Card Gothic No. 3 G \$1.50

**CARDS AND INVITATIONS
THE FOUR HUNDRED OF BOSTON**

12A 12-Point Card Gothic No. 3 H \$1.50

**NEATNESS & DESPATCH
OBTAINED AT THIS OFFICE**

**THE LOTUS GLEE CLUB
OF BOSTON.**

25 A 6-PT. CARD GOTHIC NO. 3 A \$1.00
SYMPHONY HALL

AUGUST, 1903.

**WALDORF ASTORIA
FIFTH AV.**

20 A₁ 6-PT. CARD GOTHIC NO. 3 B \$1.00
FAMILY APARTMENTS

P. HURST, MGR

20 & 5 A

18-POINT CURSIVE SCRIPT.

\$3.00

Your company is requested at the
Hansen Type Foundry, on the occasion
of its anniversary celebration. A repast of
Graceful, Artistic Types, served by our
congenial salesmen to the artists of the
typographic trade—

H. C. Hansen
Type founder
Boston

40 & 16 A

10-POINT BLACK.

\$3.74

In this cold, mercenary age,
When Mammon's hand so oft is kissed,
What joy to write on hist'ry's page
The name of a philanthropist.

Not for your princely gifts alone
In memory your name shall live,
You have a higher purpose shown
In teaching others how to give.

**SPECIAL HANDY BRACES
(Metal)**

6-Point. \$1.25 per font

LENGTH OF HANDY BRACES

These braces are used in place of piece braces, giving better results and quicker to set in position. Sizes are as follows:—

- | | | |
|----------------------|-----------------------|-----------------------|
| No. 1, 5 6-Pt. ems. | No. 2, 6½ 6-Pt. ems. | No. 3, 11½ 6-Pt. ems. |
| No. 4, 13 6-Pt. ems. | No. 5, 14½ 6-Pt. ems. | No. 6, 16½ 6-Pt. ems. |
| | No. 7, 19½ 6-Pt. ems. | |

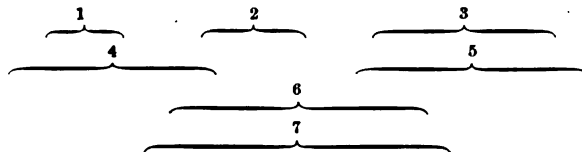

10-Pt. Modern Superior and Inferior Figures, \$1.50 per font.

1294567890

1294567890

48-Point Buffalo French Accents
\$2.00 per font

à â è é ê
ô ù û ç

BRASS POINTERS

6-Point, 10 cents each.

8-Point, 10 cents each.

12-Point, 15 cents each.



No. 27—6-Pt.



No. 25—6-Pt.



No. 37—6-Pt.



No. 38—6-Pt.



No. 26—6-Pt.



No. 28—6-Pt.



No. 29—12-Pt.



No. 33—6-Pt.



No. 39—6-Pt.



No. 40—6-Pt.



No. 34—6-Pt.



No. 30—12-Pt.



No. 31—12-Pt.



No. 35—6-Pt.



No. 41—6-Pt.



No. 42—6-Pt.



No. 36—6-Pt.



No. 32—12-Pt.



No. 3—6-Pt.



No. 1—6-Pt.



No. 2—6-Pt.



No. 4—6-Pt.



No. 7—6-Pt.



No. 5—6-Pt.



No. 6—6-Pt.



No. 8—6-Pt.

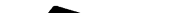

No. 12—12-Pt.



No. 20—8-Pt.



No. 21—8-Pt.



No. 13—12-Pt.



No. 10—12-Pt.



No. 16—8-Pt.



No. 17—8-Pt.



No. 11—12-Pt.



No. 14—12-Pt.



No. 18—8-Pt.



No. 19—8-Pt.



No. 15—12-Pt.

POINTERS

GROUP C, FONT \$1.30

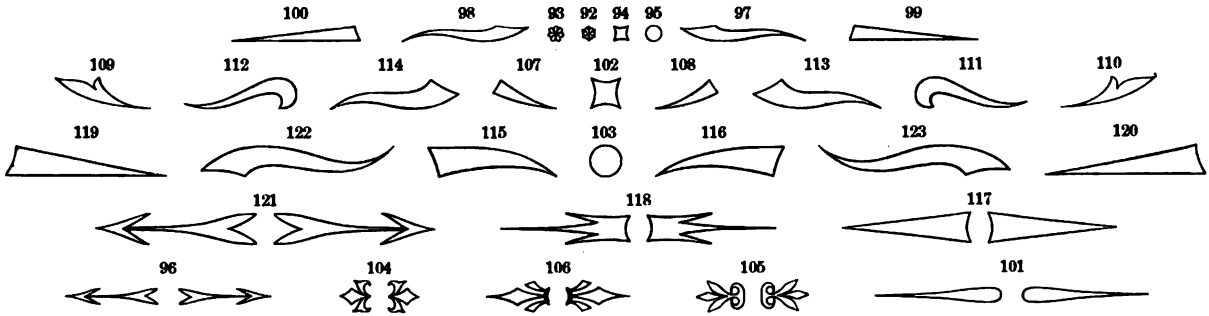

GROUP D, FONT \$1.90

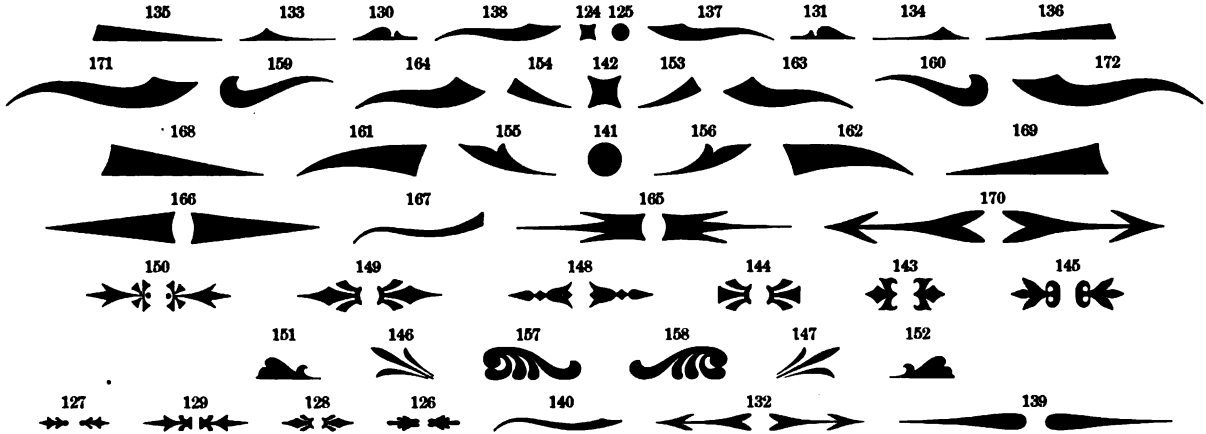

POINTERS.

Price per Font, \$1.25

A Font contains 48 of character No. 43, 20 of 44, 4 each of 45, 46, 53, 54; 3 each of 47, 48, 49, 50, 51, 52; 2 each of 55, 56, 57, 58; 4 of 60.
Cast on 6-Point and 12-Point bodies. Numbers 45, 46, 47, 48, 53, 54, 55 and 56 are made to line with our 2-Point Rule No. 109.

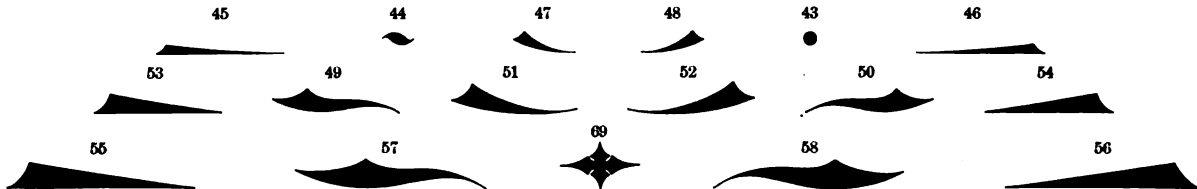

SHADED POINTERS.

Font, \$1.25

Same number of Characters as in Pointers above.

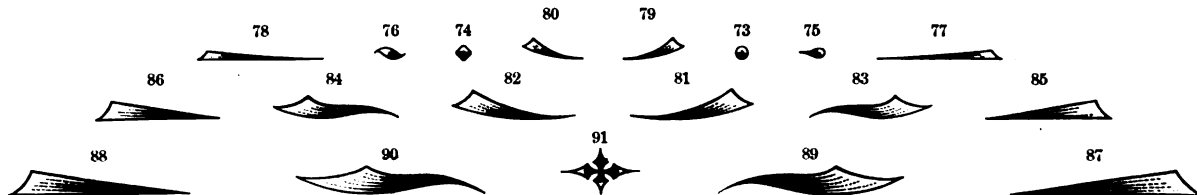

ARROW POINTERS.

Cast on 12-Point body, $2\frac{1}{2}$, 3, $3\frac{1}{2}$, 4, and $4\frac{1}{2}$, ems set and may be used right and left.

Font containing two of each character from No. 59 to 68 inclusive, \$1.00.

Also sold separately at 10 cents each.

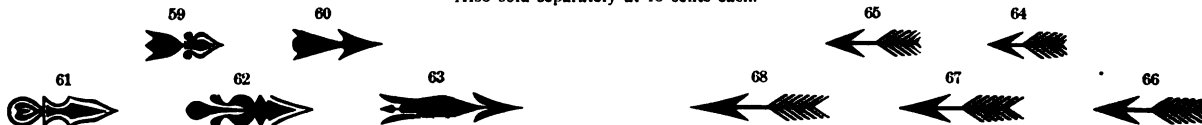

Figures Cast on Point System in Body and Thickness, for Calendar and Tabular work.

No.	6-POINT.	Pt. Set.	No.	6-POINT.	Pt. Set.	No.	8-POINT.	Pt. Set.	No.	8-POINT.	Pt. Set.
1	1234567890	3	417*	1234567890	7	367*	1234567890	4	419	1234567890	4
2	1234567890	3	206	1234567890	3	358	1234567890	4	420	1234567890	4
3	1234567890	3	206	1234567890	3½	369	1234567890	4	215	1234567890	4
4	1234567890	3	256	1234567890	4	360*	1234567890	5	267*	1234567890	6
5*	1234567890	3	267	1234567890	3½	360*	1234567890	5	268*	1234567890	4½
348	1234567890	2½	355*	1234567890	5½	361	1234567890	5½	268	1234567890	6½
349	1234567890	3	356	1234567890	4½	362*	2345678	8	313	1234567890	6½
350*	1234567890	3½	258	1234567890	3½	363*	1234567890	9½	314	1234567890	4½
351*	1234567890	3	259	1234567890	4	363*	1234567890	4	315	1234567890	6
352*	1234567890	4½	260*	1234567890	4½	364*	1234567890	4	316*	1234567890	4
353	234567890	4	261*	1234567890	6	28	1234567890	4½			
354*	1234567890	4	262*	1234567890	5	29	1234567890	5			
6†	1234567890	4	263*	1234567890	5½	29	1234567890	5			
7	1234567890	4	264*	1234567890	6	30	1234567890	5			
8	1234567890	4	265*	1234567890	7	31	1234567890	5½	38	1234567890	7
9	1234567890	4	266	1234567890	4	31	1234567890	5			
10	1234567890	5	307	1234567890	3	32	1234567890	5			
11	1234567890	4	308	1234567890	4	33	1234567890	7	39	1234567890	5
12	1234567890	4	309	1234567890	5	33	1234567890	6	40	1234567890	5
13	1234567890	4	310	1234567890	4	34	1234567890	5	41	1234567890	5
14	1234567890	4½	311*	1234567890	3	35	1234567890	5	42	1234567890	5
15†	1234567890	4½	312	1234567890	5	36*	1234567890	6½	43	1234567890	5
16	1234567890	6	418	1234567890	3	37†	1234567890	7	44	1234567890	6
17†	1234567890	5				208†	1234567890	10	45	1234567890	6
18*	1234567890	5½				209†	1234567890	10	46	1234567890	5
19†	1234567890	6	21	1234567890	5½	210	1234567890	6	47	1234567890	5½
20†	1234567890	6	22	1234567890	4½	436	1234567890	4	48*	1234567890	6
200†	1234567890	9	207	1234567890	4	211	1234567890	4½	49	1234567890	6
201†	1234567890	9				212	1234567890	5	50	1234567890	5½
435	1234567890	3½				213	1234567890	4			
202	1234567890	4½				214	1234567890	4			
203	1234567890	4	23	1234567890	4						
204	1234567890	3	24	1234567890	4						
413	1234567890	3	25	1234567890	4						
414*	1234567890	4	26	1234567890	4						
415*	1234567890	5	27*	1234567890	4						
416*	1234567890	6									

*Fig. 1, thin.

†Fig. 1, thick and thin.

Set indicates thickness of figures.

These figures can be ordered in any quantity. Job figures sold at second-class rate per lb. Roman figures sold at first-class rate per lb.

Figures Cast on Point System in Body and Thickness, for Calendar and Tabular work.

No.	10-POINT.	Pt. Set.	No.	10-POINT	Pt. Set.	No.	12-POINT.	Pt. Set.	No.	12-POINT.	Pt. Set.
220	1234567890	4	370*	234567	11	65*	1234567890	6	74*	123456789	9
221	<i>1234567890</i>	5	428	1234567890	7	66	1234567890	7	75	123456789	9
222	<i>1234567890</i>	5		11-POINT.		421	12457890	7½	76†	1234567	1
223	<i>1234567890</i>	5	56	1234567890	5½	422	1234567890	7	77†	1234567	11
224	<i>1234567890</i>	5	225	1234567890	5½	371*	1234567890	6½	230†	23456	15
268*	1234567890	7	226	1234567890	5½	372*	1234567890	6½	231†	23456	15
270	1234567890	5½	227	<i>1234567890</i>	5½	373	23456789	8	232	234567890	8
317	1234567890	6	228	<i>1234567890</i>	5½	374*	46789	13	233	1234567890	6
318	1234567890	4	229	<i>1234567890</i>	5½	375*	1234567890	6	234	<i>1234567890</i>	6
319	<i>123456789</i>	7½		12-POINT		376	12345678	8	235	<i>1234567890</i>	6
320	23567890	8	57	1234567890	6	377*	<i>1234567890</i>	7	236	<i>1234567890</i>	6
365	1234567890	5	58	1234567890	6	378	1234567890	6	255	<i>1234567890</i>	6
366*	1234567890	5	59	1234567890	6	67	1234567890	7	271*	12345678	9
367	1234567890	5	60	1234567890	6	68	1234567890	7	272	1234567890	7
368*	<i>1234567890</i>	6	61*	1234567890	6	69†	1234567890	8	273*	<i>1234567890</i>	7
369*	1234567890	5	62	1234567890	7	70†	123456789	9	274*	<i>12345678</i>	9
51	1234567890	7	63	1234567890	7	71†	2345678	10	275*	1234567	11
52	1234567890	7	64	1234567890	5	72	123456789	9	276*	1234567	11
53	23456789	9	423*	123456789	8	73	1234567890	8		<i>1234567890</i>	6
54*	234567890	8	424*	13456780	10						
55†	23456789	9	425*	1234567	11						
216†	1234567	12	426*	135790	14						
217†	234567	12									
218	1234567890	7									
219	1234567890	5									

*Figure 1, thin.

†Figure 1, thick and thin.

Set indicates thickness of figures.

These figures can be ordered in any quantity. Job figures sold at second-class rate per lb. Roman figures sold at first-class rate per lb.

Figures Cast on Point System in Body and Thickness, for Calendar and Tabular work.

No.	12-POINT	Pt. Set.	No.	16-POINT.	Pt. Set.	No.	18-POINT.	Pt. Set.	No.	18-POINT.	Pt. Set.
277*	1234567890	8	382*	<i>123456789</i>	8	388	234567	12	97*	23456	14
278*	12345678	9½	80†	<i>23456789</i>	9	389	<i>234567</i>	12	98†	23450	14
279*	123456	12	81†	234567	11	85	234567890	8	239†	567	21
321*	1234567890	4	326	<i>24567890</i>	8	86	<i>23456789</i>	9	240†	234	21
322	<i>1234567890</i>	7	18-POINT.			87*	<i>23456789</i>	9	241†	234567	11
323†	245689	11	82	<i>1234567890</i>	7	88	<i>24567890</i>	9	242	23456789	9
324	<i>234567890</i>	8	83*	1234567890	7	89	<i>234567890</i>	8	280	<i>123456789</i>	9
	14-POINT.		84*	1234567890	7	90	234567890	8	281	<i>234567890</i>	9
379*	23456789	8	383	12345678	9	91	234567890	8	282*	123456	13
380	3456789	9½	384*	<i>23456789</i>	9	92*	2345678	10	283	<i>123456789</i>	8
381	<i>3456789</i>	9½	385*	2345678	10	93†	234567	11	284*	<i>234568</i>	13
78	<i>234567890</i>	9	386*	<i>12345678</i>	8½	94	234567	11	285*	23456	15
79	23456789	9	387*	<i>123456789</i>	7½	95*	<i>234567</i>	12	286*	<i>1234567890</i>	7
237†	2345	17	96†	23456	14		234567	10	287*	26789	15
238	<i>234567890</i>	8	427*	2345678	10						
325*	<i>1234567890</i>	7									

*Figure 1, thin. †Figure 1, thick and thin. Set indicates thickness of figures. These figures can be ordered in any quantity. Sold at second-class rate per lb.

Figures Cast on Point System in Body and Thickness for Calendar and Tabular work.

No.	18-POINT	Pt. Set.	No.	24-POINT.	Pt. Set.	No.	24-POINT.	Pt. Set.	No.	24-POINT	Pt. Set.
288*	3568	19	391*	1234567	11	110*	2345	16	245†	2345	17
327*	23456789	8	392*	234567	12	111	23456	14	246	234567	12
328	2345678	10	393	3456	16	112	234567	114*	289	23567	14
329*	4567	17	394	3478	16	113	234567	11	290*	5789	18
341*	123456	10	103†	23456	14	114*	234567	11	291†	234798	12
346*	769896	9½	104*	234568	12	115	234567	12	292*	568	20
	20-POINT		105	23456789	9	116†	2345	16	293*	247	22
99†	1234567	12	106	2345678	10	117†	2345	18	294*	2345678	10
100*	234567890	9	107	2345678	10	118†	234	19	295†	135	27
101	23456789	9	108	234567	11	119†	2345	17	296*	245	25
102†	23456	13									
243†	23456	13									

*Figure 1, thin. †Figure 1, thick and thin. Set indicates thickness of figures.
 These figures can be ordered in any quantity. Sold at second-class rate per lb.

Figures Cast on Point System in Body and Thickness for Calendar and Tabular work.

No.	24-POINT	Pt. Set.	No.	30-POINT.	Pt. Set.	No.	30-POINT	Pt. Set.	No.	30-POINT.	Pt. Set.
331	12560	12	396*	12345	15	248†	2580	15	122	2345	15
332*	234567	10	307*	12345	15	297†	23458	14	123	2345	15
342*	45789	13	308*	123456	14	296*	123458	13	124	12345	16
395*	123456	12	399	4567	18	333*	3456	12½	36-POINT		
109	23456	12½	400	4567	18	334	4567	15	402*	5678	17½
244†	264	25	401*	46789	15	120†	12864	16	403*	1234	19
330*	235	22	125*	345	20	121	26354	13	404*	1234	17½
429*	23456	13	128†	234	25	247*	80	34	250†	8650	18
390*	34567	13									

Figure 1, thin. †Figure 1 thick and thin. Set indicates thickness of figures. These figures can be ordered in any quantity. Sold at second-class rate per lb.

Figures Cast on Point System in Body and Thickness for Calendar and Tabular work.

No.	36-POINT.	Pt. Set.	No.	36-POINT.	Pt. Set.	No.	36-POINT.	Pt. Set.	No.	36-POINT.	Pt. Set.
133	2345	16	405	345	23	335*	4567	15*	302†	458	24
132*	34568	15	406	345	23	336	348	18	249†	468	20
134	328	21	127†	286	22	345*	12480	14		42-POINT.	
135	235	20	128	57930	14	230*	436	24	139	259	24
136	368	23	129	57930	14	300*	23457	15	140*	3568	18
137†	98	28	130	23458	12½	343*	3579	17	141	680	16
138†	45	28	131	3456	17	301†	85	38	142	5893	18

*Figure 1, thin.

†Figure 1, thick and thin.

Set indicates thickness of figures.

These figures can be ordered in any quantity. Sold at second-class rate per lb.

Figures Cast on Point System in Body and Thickness for Calendar and Tabular work.

No.	42-POINT.	Pt. Set.	No.	42-POINT	Pt. Set.	No.	42-POINT.	Pt. Set.	No.	48-POINT	Pt. Set.
344*	236	21	406*	234	22	303*	24567	15	153	95	32
407*	560	22	409*	3456	16		48-POINT.				
						148	3489	15	154*	685	22
337	379	21	145	589	23						
						149	423	23	155	83	41
338*	190	18	146†	25	33						
143	3567	13	251†	235	24	150	985	23	156*	58	40
144	3567	18	252†	805	21	151*	53	27	253†	85	28

*Figure 1, thin.

†Figure 1, thick and thin.

Set indicates thickness of figures.

These figures can be ordered in any quantity.

Sold at second-class rate per lb.

Figures Cast on Point System in Body and Thickness for Calendar and Tabular work.

No.	48-POINT	Pt. Set.	No.	48-POINT	Pt. Set.	No.	48-POINT	Pt. Set.	No.	54-POINT	Pt. Set.
254†	325	24	347*	315	24	152	80	28	*	172	29
304†	2534	19	340*	180	21	147*	86	28			
										60-POINT	
305*	54	35	410	28	31½	430*	6790	19	433	26	42
306†	32	32	411	35	31½	431*	246	23		72-POINT	
339	524	24	412*	123	26	432*	678	26	434	8	48

*Figure 1, thin.

†Figure 1, thick and thin.

Set indicates thickness of figures.

These figures can be ordered in any quantity. Sold at second-class rate per lb.

Private Mailing Card, \$1.25

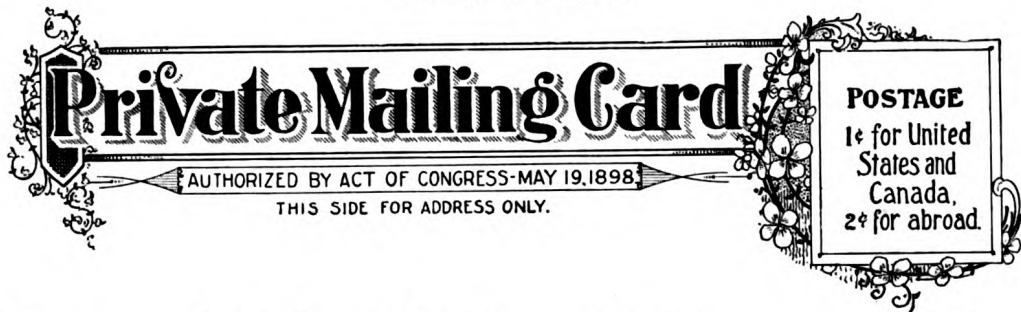

No. 1, 40 cents.



No. 2, 30 cents

or order

No. 3, 30 cents

or bearer

No. 4, 20 cents

To after date

No. 6, 30 cents

Bought of

No. 7, 35 cents

After date

No. 5, 35 cents

No. 8, 20 cents

Pr

No. 9, 20 cents

No.

No. 10, 15 cents

\$

No. 11, 30 cents



No. 12, 35 cents

Dollars

No. 13, 35 cents

Value received

No. 14, 35 cents

promise to pay

Panel Borders

Square and Round Corners, made for
Brass and Metal Rule.

BORDERS FOR NEWSPAPER ADS.



Panel Border, No. 3 6-Point. 5-ft. \$1.40

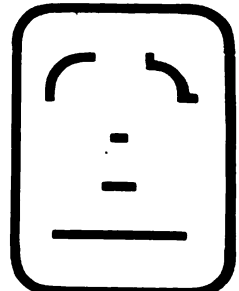
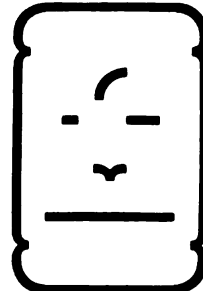
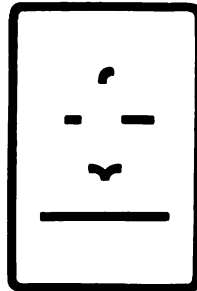
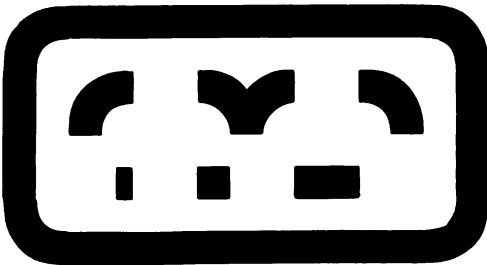

Panel Border, No. 1 3-Point on 6-Point. 5-ft. \$1.40

4-Point face
Sq. and Round
Corners
25c. per set.
Metal or Brass Rule
sold separately

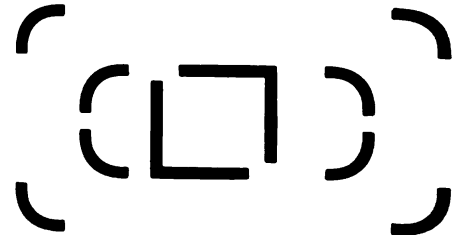

Panel Border,
No. 1 12-Pt. 5-ft. \$1.60

With Round and
Square Corners.

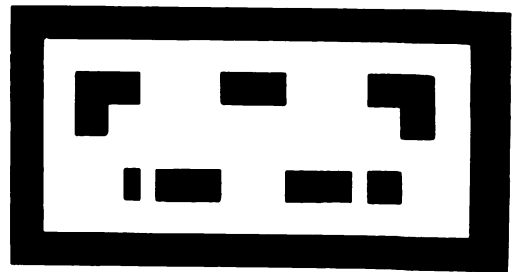

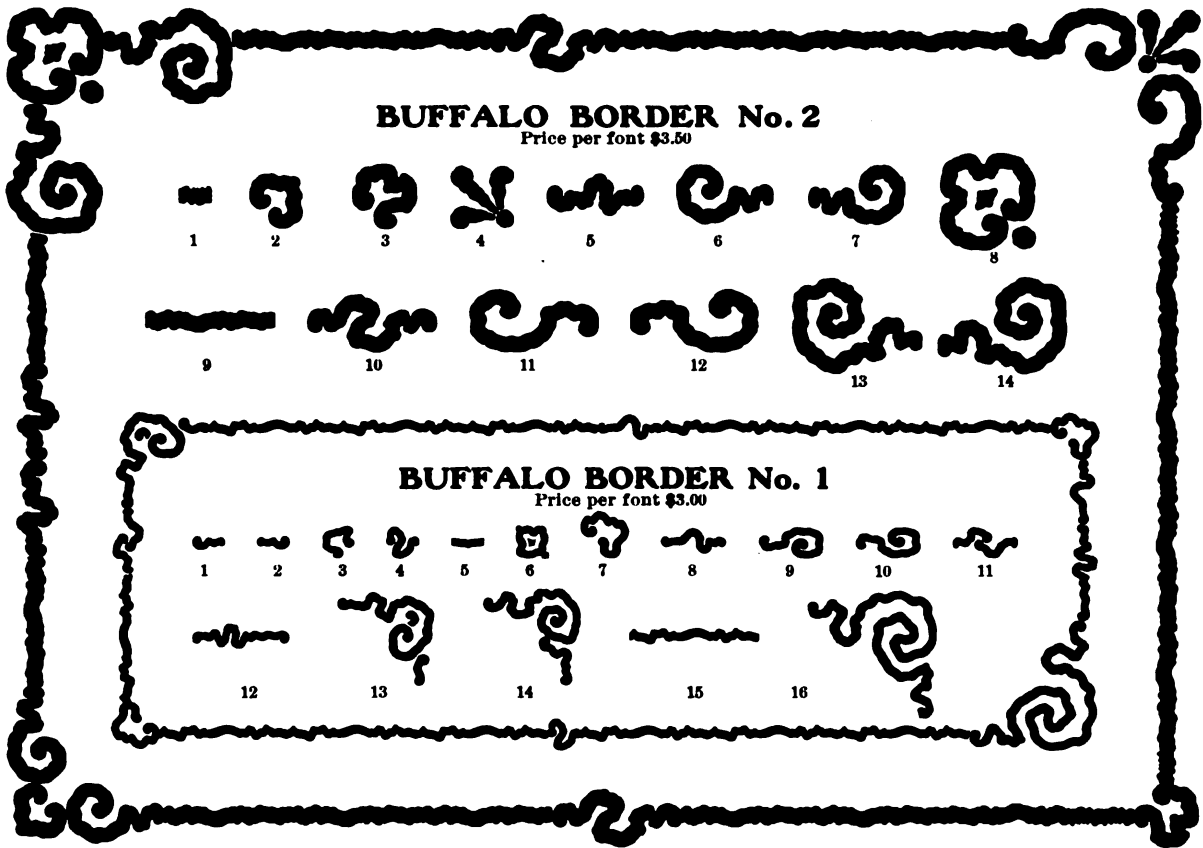

BUFFALO BORDER No. 2

Price per font \$3.50



BUFFALO BORDER No. 1

Price per font \$3.00



Buffalo Border No. 3

60-inch font, \$3.00



**BORDERS
AND
BANDS**

No. 214,
12-Pt. 36-in. Font, \$1.50



No. 216,
18-Pt. 30-in. Font, \$1.50



No. 218
24-Pt. 24-in. Font, \$1.50



Band No. 220
24-Pt. Foot, \$.75



No. 222 12-Pt.
36-in. Font \$1.50



No. 223 18-Pt.
30-in. Font, \$1.50



No. 215
12-Pt. 36-in. Font, \$1.50



No. 217
18-Pt. 30-in. Font, \$1.50



No. 219
24-Pt. 24-in. Font, \$1.50



Band No. 221
36-Pt. Foot, \$1.00



No. 224 24-Pt.
24-in. Font, \$1.50





STUDIO ORNAMENTS

\$6.00 PER FONT

\$3.00 PER HALF-FONT



168



169



170



171



172



173



174



175



176



177



178



179



180



181



182



183



184



185



186



187



188



189



No. 336. 18-Pt.

No. 337. 18-Pt.

BORDERS AND ORNAMENTS

Font, 48 inches, 12-Point, \$1.50. Per foot, \$.45
 Font, 48 inches, 18-Point, \$1.80 Per foot, \$.50
 30-Point, per foot, \$.60 42-Point, per foot, \$1.25
 36-Point, per foot, 1.00 48-Point, per foot, 1.50
 Single characters of any Border 10c. each.

No. 338. 24-Pt.

24-Pt. Foot, 75c.

No. 339. 24-Pt.



No. 190. 12-Pt.

No. 197. 12-Pt.



No. 340. 36-Pt.

No. 341. 36-Pt.

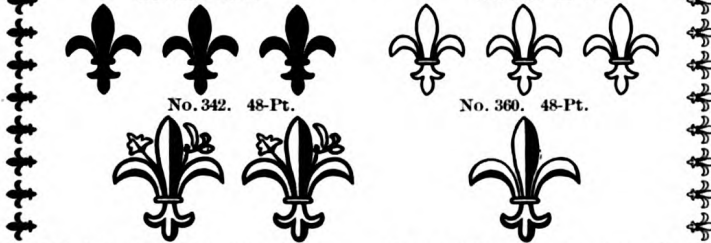

No. 342. 48-Pt.

No. 360. 48-Pt.



No. 343. 6-Pt. 5c.

No. 344. 6-Pt. 5c.

No. 345. 6-Pt. 5c.

No. 346. 6-Pt. 5c.



No. 347. 8-Pt. 5c.

No. 348. 8-Pt. 5c.



No. 349. 12-Pt. 5c.

No. 350. 12-Pt. 5c.

No. 351. 18-Pt. 5c.



No. 352. 30-Pt.

No. 353. 30-Pt.

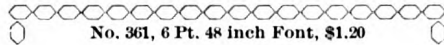

No. 361, 6 Pt. 48 inch Font, \$1.20



No. 160, 12 Pt. 48 inch Font, \$1.50



No. 166, 18 Pt. 48 inch Font, \$1.80

No. 354. 36-Pt.

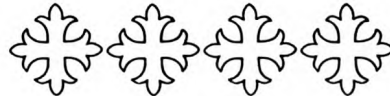

No. 355. 42-Pt.



No. 356. 42-Pt.

No. 357. 42-Pt.



No. 358. 48-Pt.

No. 359. 48-Pt.



STUDIO ORNAMENTS



No. 168, 6-Pt. 40 cents per foot

No. 169 12-Pt. No. 170
50 cents per foot

No. 171, 12-Pt. 50 cents per foot



No. 172, 12-Pt. 50 cents per foot



No. 174, 18-Pt. 75 cents per foot



No. 176, 24-Pt. \$1.00 per foot



No. 189, 24-Pt. \$1.00 per foot



No. 173, 12-Pt. 50 cents per foot

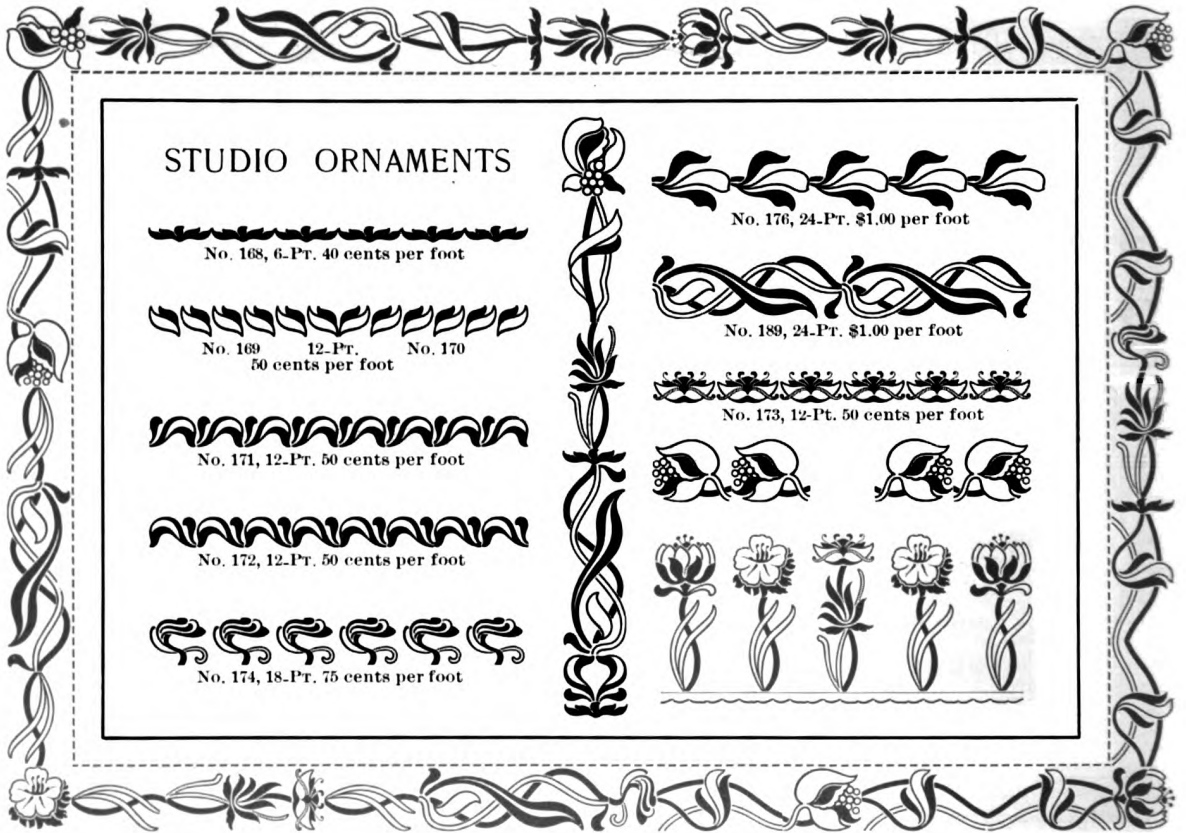

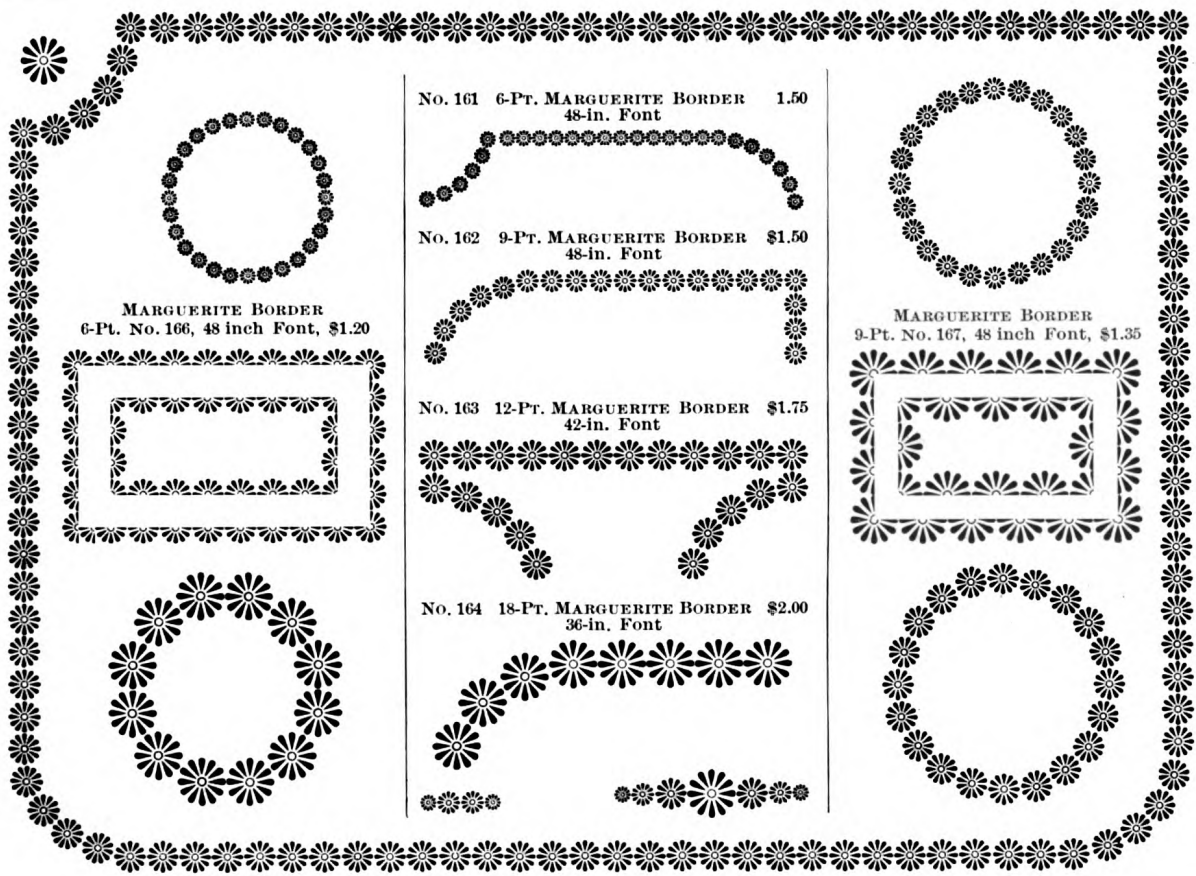

MARGUERITE BORDER
6-Pt. No. 166, 48 inch Font, \$1.20

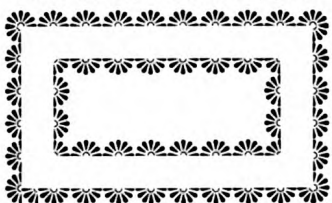

No. 161 6-Pt. MARGUERITE BORDER 1.50
48-in. Font



No. 162 9-Pt. MARGUERITE BORDER \$1.50
48-in. Font



No. 163 12-Pt. MARGUERITE BORDER \$1.75
42-in. Font



No. 164 18-Pt. MARGUERITE BORDER \$2.00
36-in. Font



MARGUERITE BORDER
9-Pt. No. 167, 48 inch Font, \$1.35



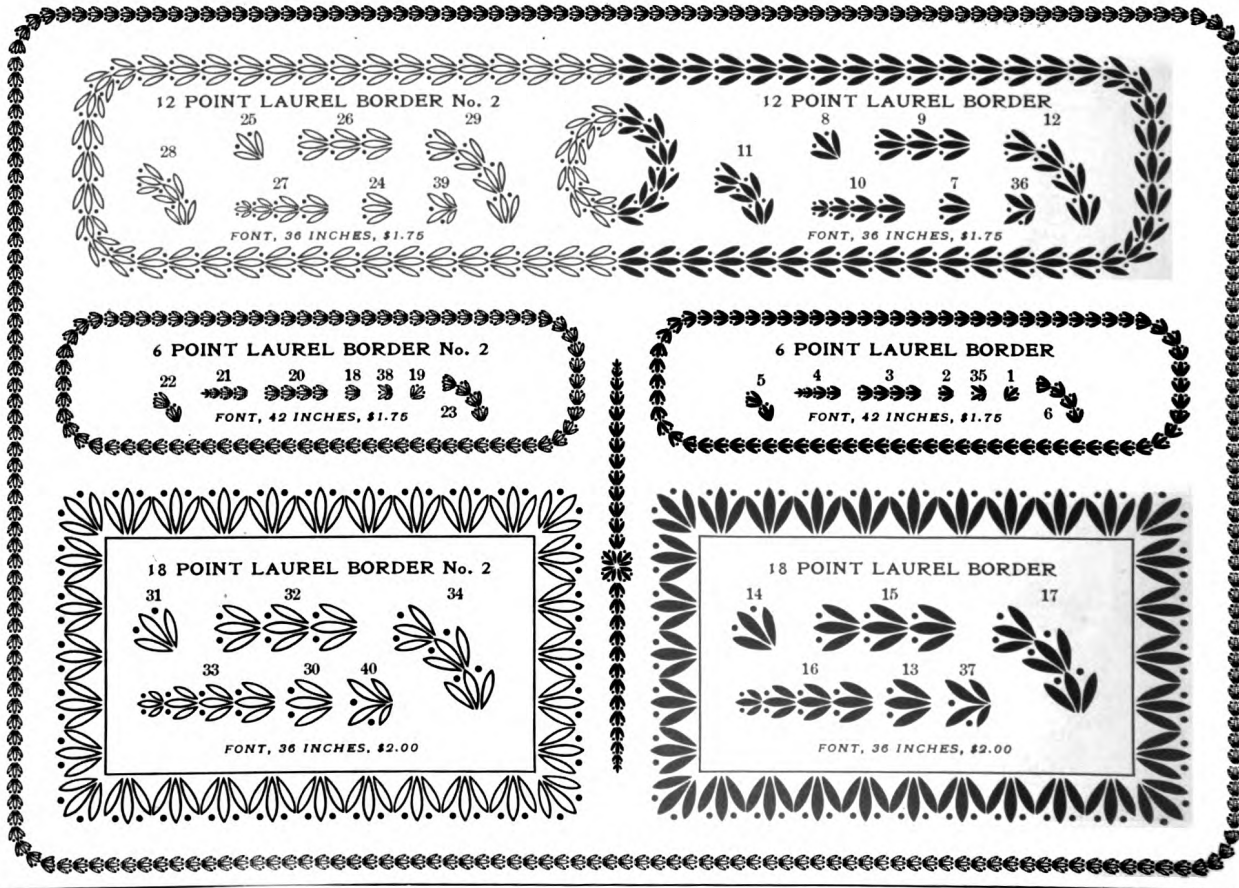

12 POINT LAUREL BORDER No. 2

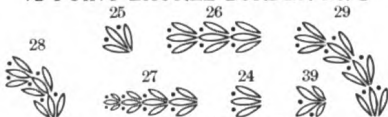

FONT, 36 INCHES, \$1.75

12 POINT LAUREL BORDER



FONT, 36 INCHES, \$1.75

6 POINT LAUREL BORDER No. 2

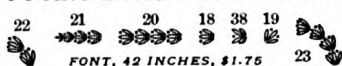

FONT, 42 INCHES, \$1.75

6 POINT LAUREL BORDER



FONT, 42 INCHES, \$1.75

18 POINT LAUREL BORDER No. 2

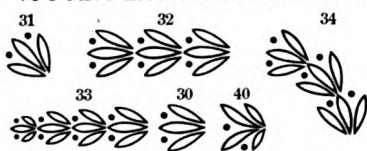

FONT, 36 INCHES, \$2.00

18 POINT LAUREL BORDER



FONT, 36 INCHES, \$2.00

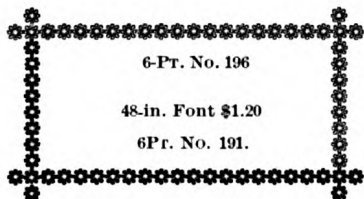
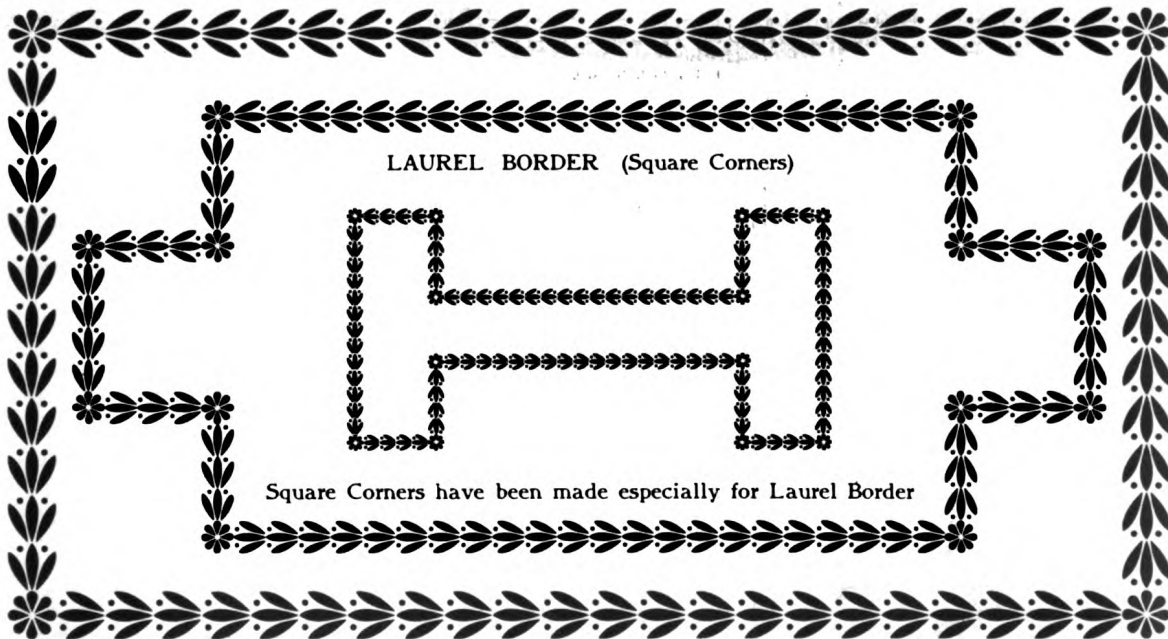

MULTIPLEX BORDERS.

Font, 48 inches, 6-Point, \$1.20.

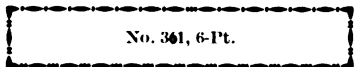

No. 361, 6-Pt.

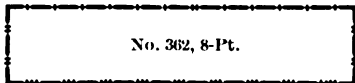

No. 362, 8-Pt.

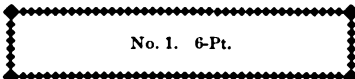

No. 1. 6-Pt.

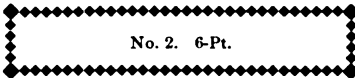

No. 2. 6-Pt.

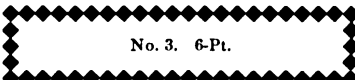

No. 3. 6-Pt.

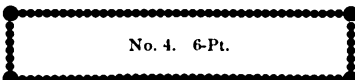

No. 4. 6-Pt.

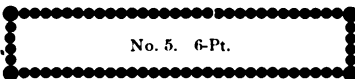

No. 5. 6-Pt.

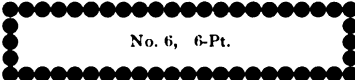

No. 6. 6-Pt.

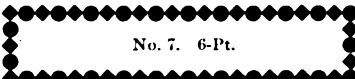

No. 7. 6-Pt.

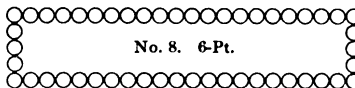

No. 8. 6-Pt.

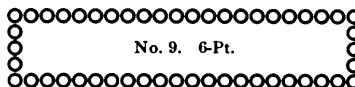

No. 9. 6-Pt.

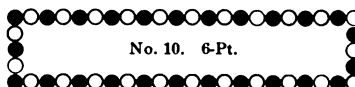

No. 10. 6-Pt.

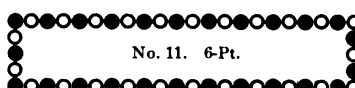

No. 11. 6-Pt.

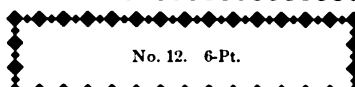

No. 12. 6-Pt.

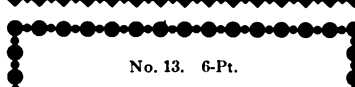

No. 13. 6-Pt.

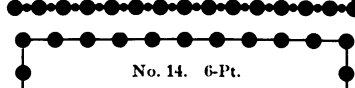

No. 14. 6-Pt.

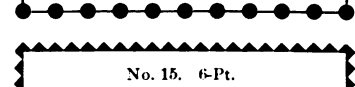

No. 15. 6-Pt.

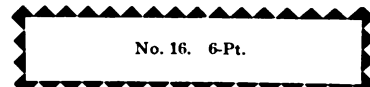

No. 16. 6-Pt.

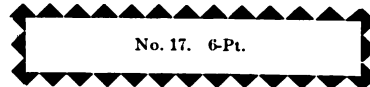

No. 17. 6-Pt.

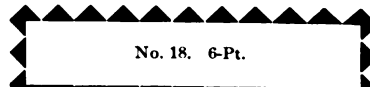

No. 18. 6-Pt.

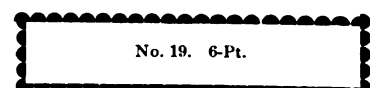

No. 19. 6-Pt.

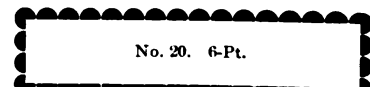

No. 20. 6-Pt.

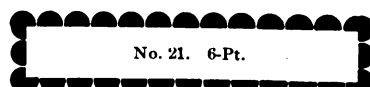

No. 21. 6-Pt.

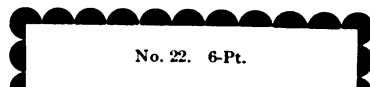

No. 22. 6-Pt.

MULTIPLEX BORDERS.

Font, 48 Inches, 6-Point, \$1.20.
Font, 48 Inches, 8-Point, 1.25.

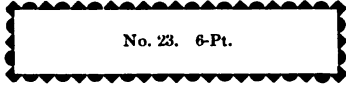

No. 23. 6-Pt.

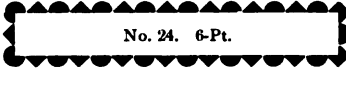

No. 24. 6-Pt.



No. 25. 6-Pt.

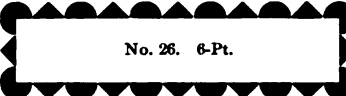

No. 26. 6-Pt.

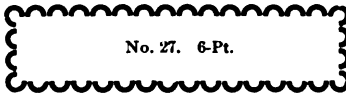

No. 27. 6-Pt.

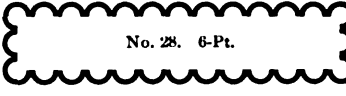

No. 28. 6-Pt.

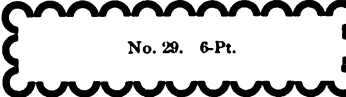

No. 29. 6-Pt.

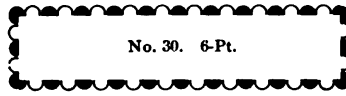

No. 30. 6-Pt.

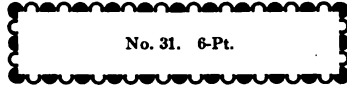

No. 31. 6-Pt.

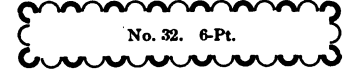

No. 32. 6-Pt.



No. 33. 6-Pt.

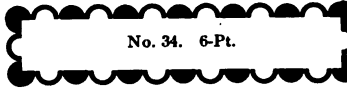

No. 34. 6-Pt.

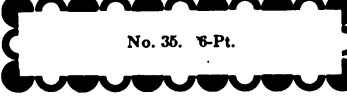

No. 35. 6-Pt.

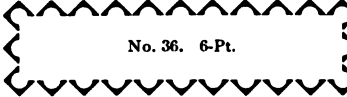

No. 36. 6-Pt.

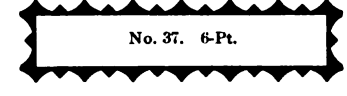

No. 37. 6-Pt.

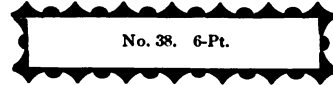

No. 38. 6-Pt.

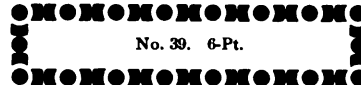

No. 39. 6-Pt.

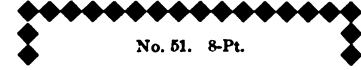

No. 51. 8-Pt.

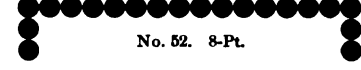

No. 52. 8-Pt.

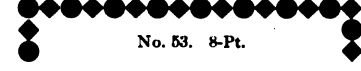

No. 53. 8-Pt.

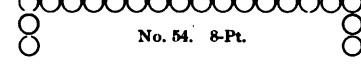

No. 54. 8-Pt.

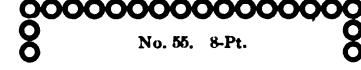

No. 55. 8-Pt.

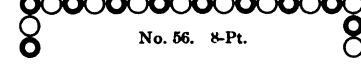

No. 56. 8-Pt.

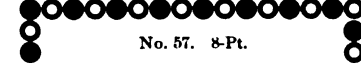

No. 57. 8-Pt.

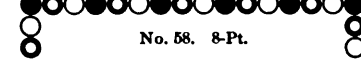

No. 58. 8-Pt.

MULTIPLEX BORDERS.

Font, 48 inches, 8-Point, \$r.25
 Font, 48 inches, 10-Point, r.35
 Font, 48 inches, 12-Point, r.50
 One Foot 12-Point, - - .45

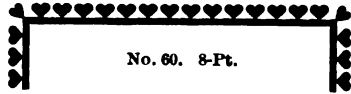

No. 60. 8-Pt.

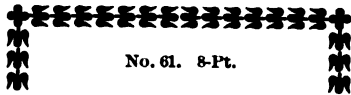

No. 61. 8-Pt.

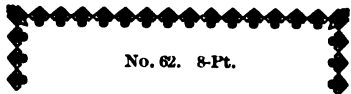

No. 62. 8-Pt.

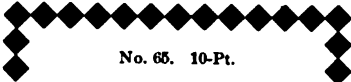

No. 65. 10-Pt.

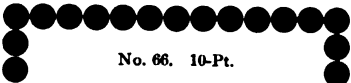

No. 66. 10-Pt.

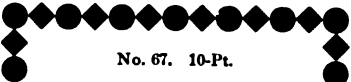

No. 67. 10-Pt.

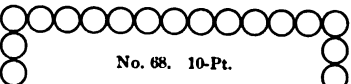

No. 68. 10-Pt.

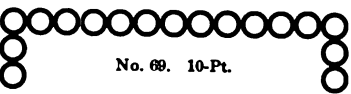

No. 69. 10-Pt.



No. 70. 10-Pt.

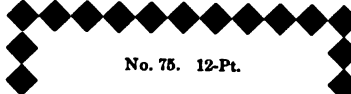

No. 75. 12-Pt.

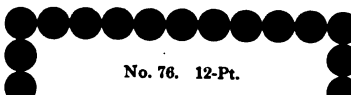

No. 76. 12-Pt.

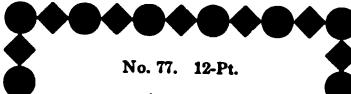

No. 77. 12-Pt.

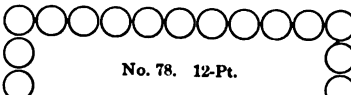

No. 78. 12-Pt.

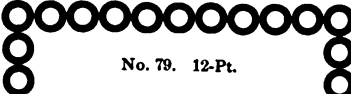

No. 79. 12-Pt.

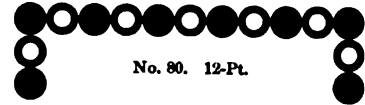

No. 80. 12-Pt.

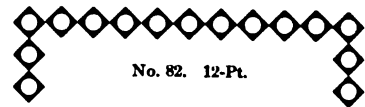

No. 82. 12-Pt.

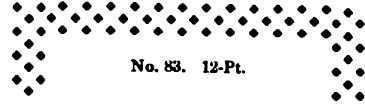

No. 83. 12-Pt.

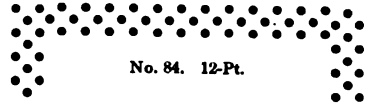

No. 84. 12-Pt.

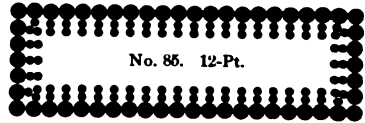

No. 85. 12-Pt.

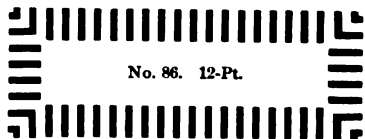

No. 86. 12-Pt.

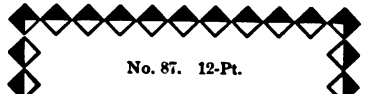

No. 87. 12-Pt.

MULTIPLEX BORDERS.

Font, 48 inches, 9-Pt. \$1.35
 Font, 48 inches, 12-Pt. \$1.50 One Foot 12-Pt. \$.45
 Font, 48 inches, 18-Pt. 1.80 One Foot 18-Pt. .50

No. 500. No. 59. No. 71. No. 81

6-Pt. 8-Pt. 10-Pt. 12-Pt.

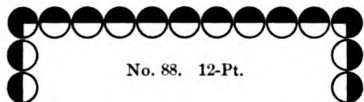

No. 88. 12-Pt.

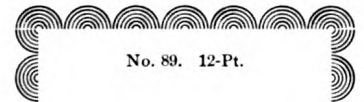

No. 89. 12-Pt.

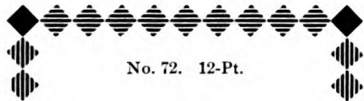

No. 72. 12-Pt.

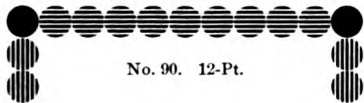

No. 90. 12-Pt.

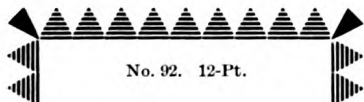

No. 92. 12-Pt.

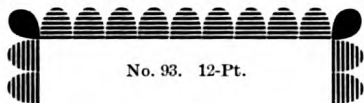

No. 93. 12-Pt.

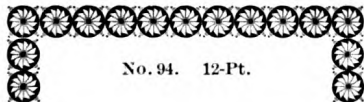

No. 94. 12-Pt.

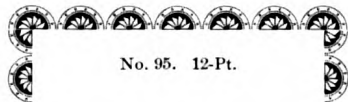

No. 95. 12-Pt.

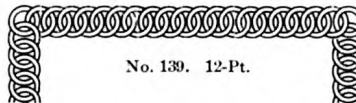

No. 139. 12-Pt.

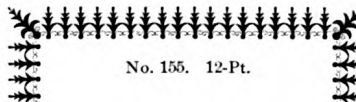

No. 155. 12-Pt.

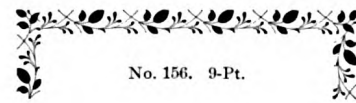

No. 156. 9-Pt.

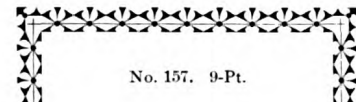

No. 157. 9-Pt.

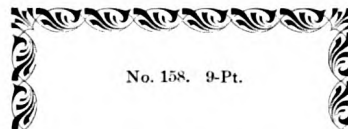

No. 158. 9-Pt.

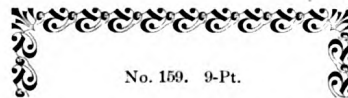

No. 159. 9-Pt.

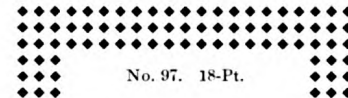

No. 97. 18-Pt.

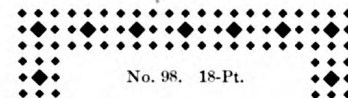

No. 98. 18-Pt.



No. 118. 18-Pt.



No. 119. 18-Pt.



No. 120. 18-Pt.

BORDERS

Font, 48 inches, 18-Pt., \$1.80 Per foot, \$.50

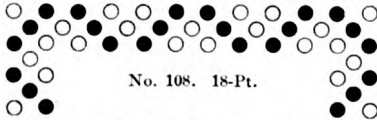

No. 108. 18-Pt.

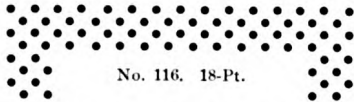

No. 116. 18-Pt.

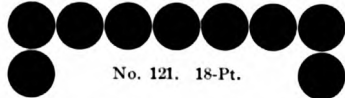

No. 121. 18-Pt.



No. 123. 18-Pt.

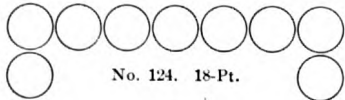

No. 124. 18-Pt.

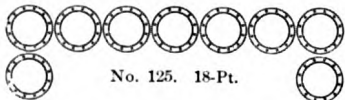

No. 125. 18-Pt.



No. 127. 18-Pt.

ORNAMENTS

Each character in sets of 4 at 40c. per set.

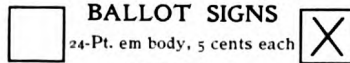
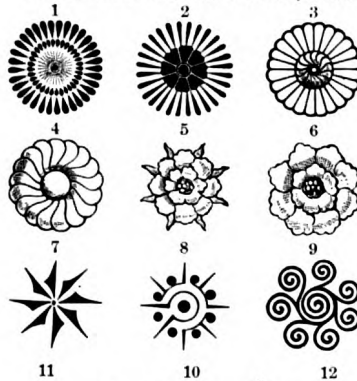

BALLOT SIGNS

24-Pt. em body, 5 cents each

BANDS

30-Pt., per foot, \$.60 42-Pt., per foot, \$1.25
No. 153. 30-Pt. No. 154. 42-Pt.

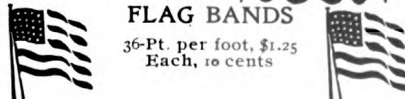

FLAG BANDS

36-Pt. per foot, \$1.25
Each, 10 cents

METAL RULE

In strips
18 in. long.
PER FOOT.

	2-Pt.	5 cts
	3-Pt.	8 cts
	4-Pt.	10 cts
	5-Pt.	12 cts
No. 1.	6-Pt.	15 cts.
No. 2.	8-Pt.	20 cts.
No. 3.	12-Pt.	30 cts.
No. 5.	18-Pt.	45 cts.
No. 6.	24-Pt.	60 cts.
No. 7.	18-Pt.	45 cts.
No. 8.	24-Pt.	60 cts.
No. 9.	12-Pt.	35 cts.
No. 10.	18-Pt.	50 cts.
No. 11.	24-Pt.	60 cts.

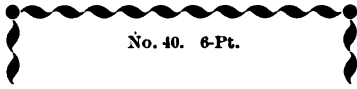

No. 40. 6-Pt.

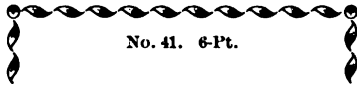

No. 41. 6-Pt.

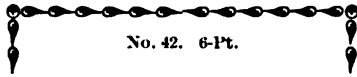

No. 42. 6-Pt.

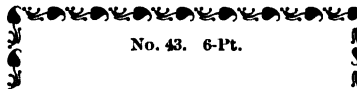

No. 43. 6-Pt.

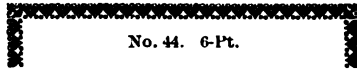

No. 44. 6-Pt.

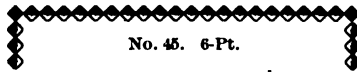

No. 45. 6-Pt.

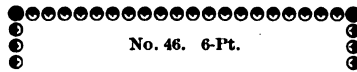

No. 46. 6-Pt.

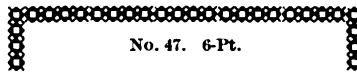

No. 47. 6-Pt.

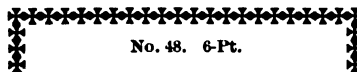

No. 48. 6-Pt.

WILLIS BORDERS

Font, 48 inches, 6-Point, \$1.20

Font, 48 inches, 8-Point, 1.25

Font, 48 inches, 10-Point, 1.35

Font, 48 inches, 12-Point, 1.50

One Foot, 12-Point,45

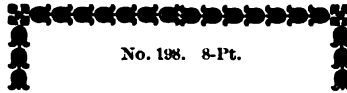

No. 198. 8-Pt.

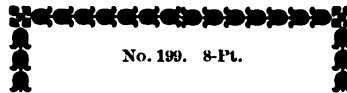

No. 199. 8-Pt.

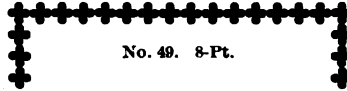

No. 49. 8-Pt.

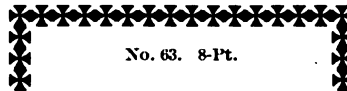

No. 63. 8-Pt.

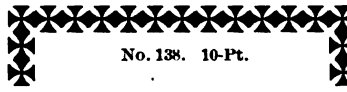

No. 138. 10-Pt.



No. 74. 12-Pt.

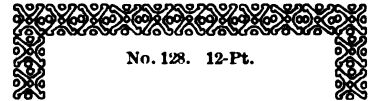

No. 128. 12-Pt.

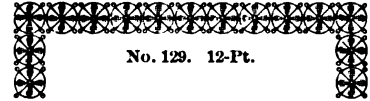

No. 129. 12-Pt.

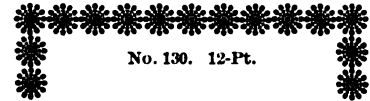

No. 130. 12-Pt.

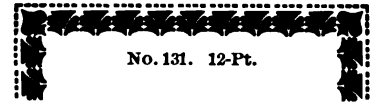

No. 131. 12-Pt.

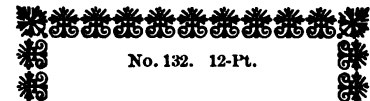

No. 132. 12-Pt.

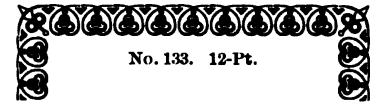

No. 133. 12-Pt.

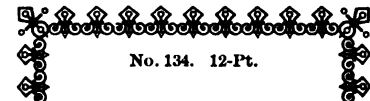

No. 134. 12-Pt.

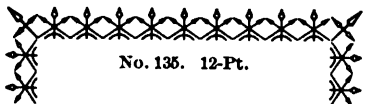

No. 135. 12-Pt.

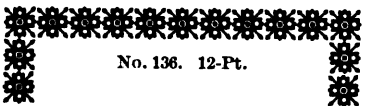

No. 136. 12-Pt.

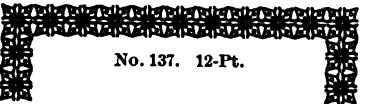

No. 137. 12-Pt.

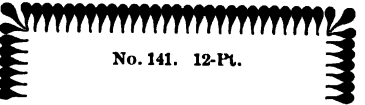

No. 141. 12-Pt.

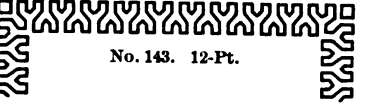

No. 143. 12-Pt.

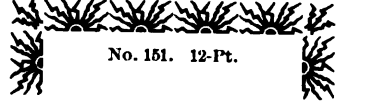

No. 151. 12-Pt.

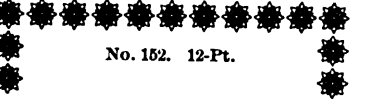

No. 152. 12-Pt.



No. 150. 24-Pt.

**WILLIS BORDERS
AND BANDS.**

Font, 48 in. 8-Pt., \$1.25
 Font, 48 in. 12-Pt., \$1.25. One Foot, \$.45
 Font, 48 in. 18-Pt., 1.80. One Foot, .50
 Font, 48 in. 24-Pt., 2.25. One Foot, .75



No. 145. 18-Pt. 20-inch font, \$1.50



No. 366, 24-Pt. 20-inch font, \$1.50



No. 367, 36-Pt. 18-inch font, \$1.50



No. 147. 18-Pt.



No. 148. 18-Pt.



No. 146. 18-Pt.

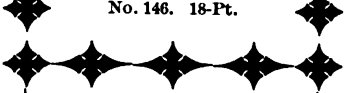

No. 149. 18-Pt.

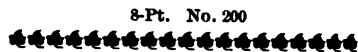

8-Pt. No. 200

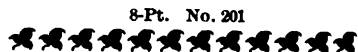

8-Pt. No. 201

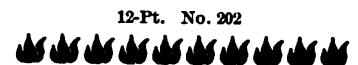

12-Pt. No. 202

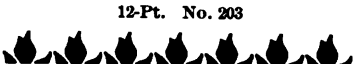

12-Pt. No. 203



12-Pt. No. 204



12-Pt. No. 205

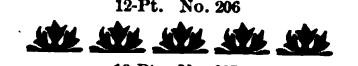

12-Pt. No. 206

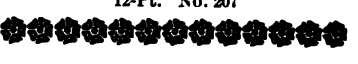

12-Pt. No. 207

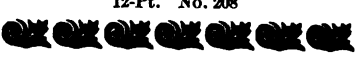

12-Pt. No. 208

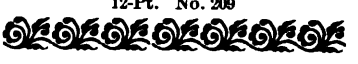

12-Pt. No. 209

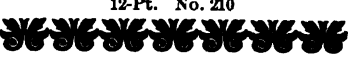

12-Pt. No. 210

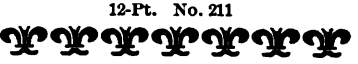

12-Pt. No. 211



12-Pt. No. 212

BORDERS

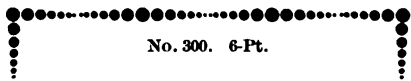

No. 300. 6-Pt.

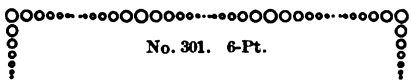

No. 301. 6-Pt.

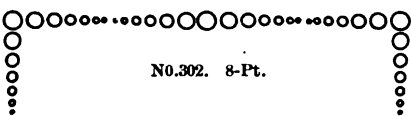

No. 302. 8-Pt.

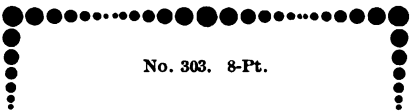

No. 303. 8-Pt.

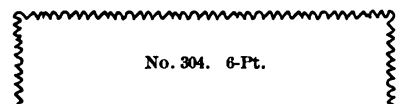

No. 304. 6-Pt.

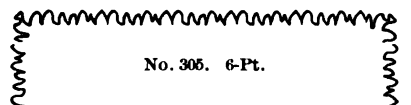

No. 305. 6-Pt.

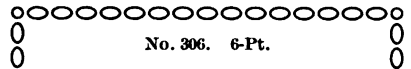

No. 306. 6-Pt.

Font, 48 inches, 6-Pt., \$1.20
 Font, 48 inches, 8-Pt., 1.25
 Font, 48 inches, 12-Pt., \$1.50 Per foot, \$.45
 Font, 48 inches, 18-Pt., 1.80 Per foot, .50
 Font, 48 inches, 24-Pt., 2.25 Per foot, .75



No. 307. 8-Pt.

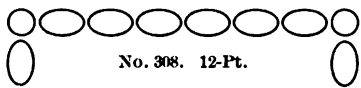

No. 308. 12-Pt.

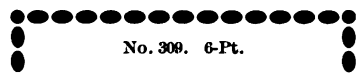

No. 309. 6-Pt.

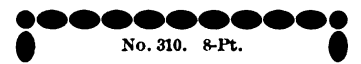

No. 310. 8-Pt.

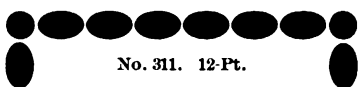

No. 311. 12-Pt.

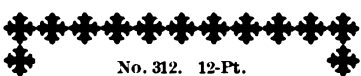

No. 312. 12-Pt.

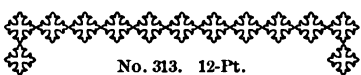

No. 313. 12-Pt.

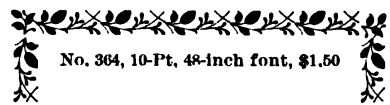

No. 304, 10-Pt, 48-inch font, \$1.50

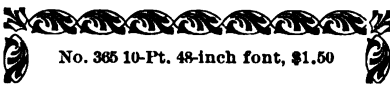

No. 305 10-Pt, 48-inch font, \$1.50

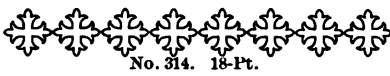

No. 314. 18-Pt.

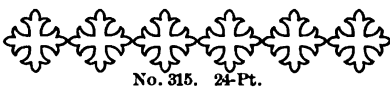

No. 315. 24-Pt.

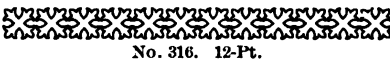

No. 316. 12-Pt.

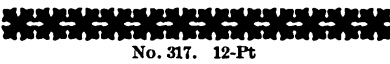

No. 317. 12-Pt

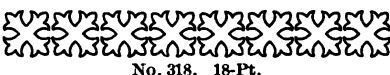

No. 318. 18-Pt.

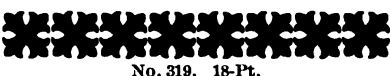

No. 319. 18-Pt.



No. 320. 24-Pt.



No. 321. 24-Pt.

No. 322. 18-Pt.



No. 323. 18-Pt.

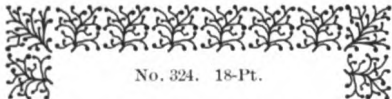

No. 324. 18-Pt.

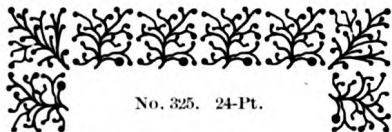

No. 325. 24-Pt.

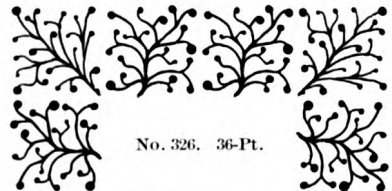

No. 326. 36-Pt.

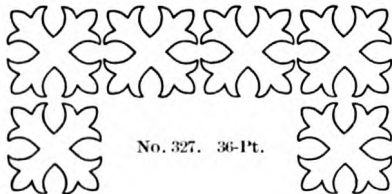

No. 327. 36-Pt.

BORDERS

Font. 48 inches, 18-Pt., \$1.80 Per foot, \$.50

Font. 48 inches, 24-Pt., 2.25 Per foot, .75

36-Pt., per foot, \$1.00



No. 328. 18-Pt.

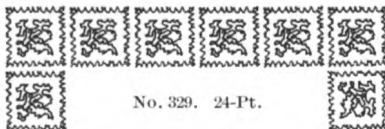

No. 329. 24-Pt.

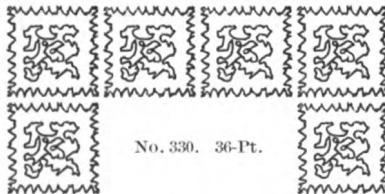

No. 330. 36-Pt.

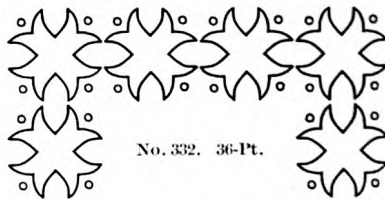

No. 332. 36-Pt.

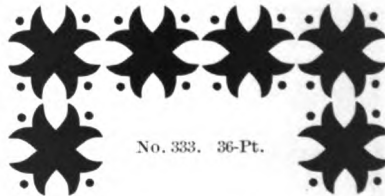

No. 333. 36-Pt.

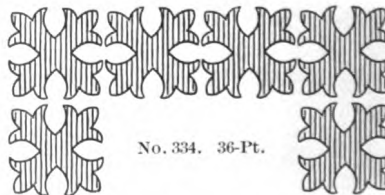

No. 334. 36-Pt.

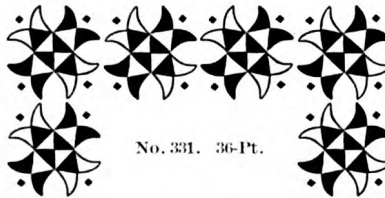

No. 331. 36-Pt.

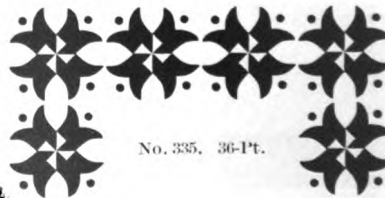

No. 335. 36-Pt.

WORD * ORNAMENTS. ♪

Font containing 3 of each character from 6-Pt. to 12-Pt., 2 each from 14-Pt. to 24-Pt., and 1 each from 30-Pt. to 48-Pt., \$1.50.

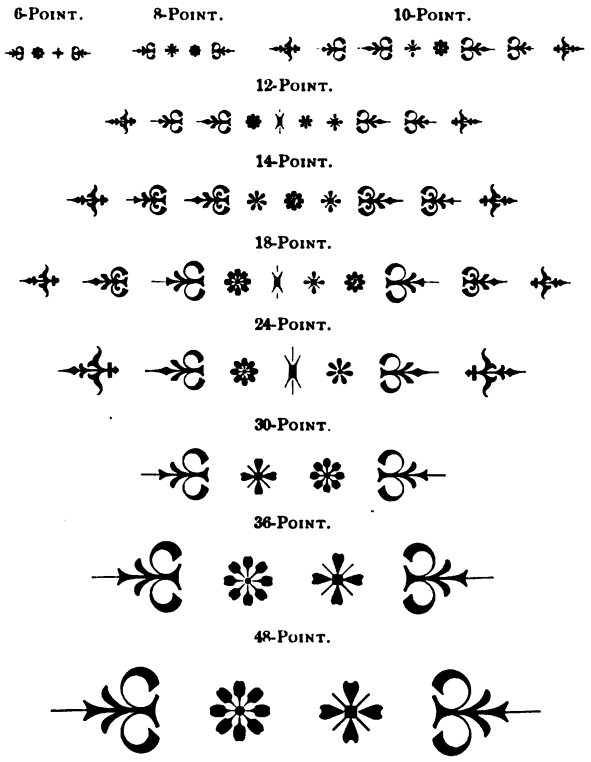

HANSEN ORNAMENTS.

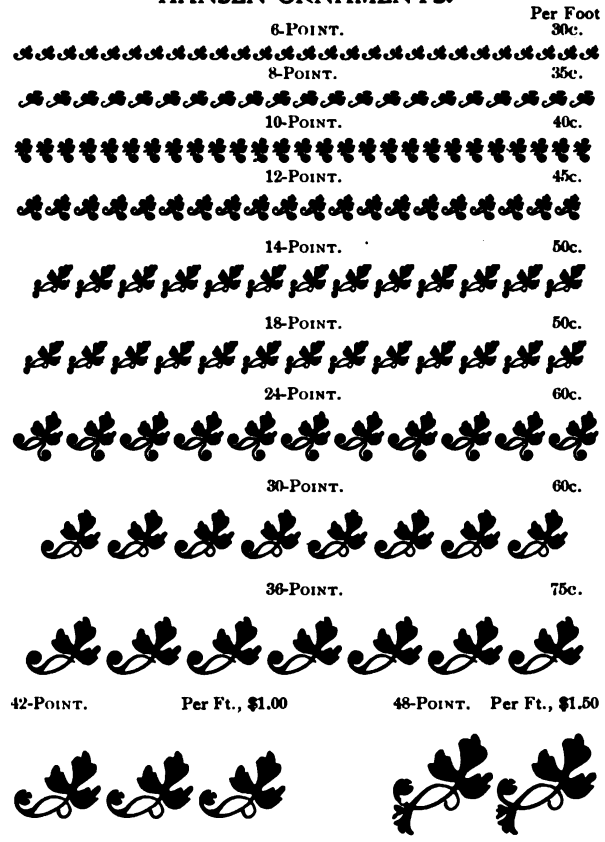



HOLLY BORDER

One Color, 36-inch font, \$3.00
Two colors, 18 inches, \$3.00 Two colors, 36 inches, \$6.00

BUFFALO AND BUFFALO OUTLINE ORNAMENTS

6-Point, 30 cents per foot *****	8-Point, 35 cents per foot *****
10-Point, 40 cents per foot *****	12-Point, 45 cents per foot *****
12-Point, 45 cents per foot *****	14-Point, 50 cents per foot *****
18-Point, 50 cents per foot *****	14-Point, 50 cents per foot *****
18-Point, 50 cents per foot *****	24-Point, 60 cents per foot *****
30-Point, 60 cents per foot *****	36-Point, 75 cents per foot *****
48-Point, \$1.50 per foot *****	



6-LINE GOTHIC CONDENSED No. 1 6c. per letter

**WOOD TYPE SOLD BY
H. C. HANSEN**

10-LINE GOTHIC CONDENSED No. 1 9c. per letter

CON. GOTHIC

WOOD TYPE

5-LINE BUFFALO 6c. per letter

REMOVAL

6-LINE BUFFALO 6c. per letter

SUMMER

8-LINE BUFFALO 8c. per letter

Place

3A Font, 75 letters.

4A " 106 "

5A " 120 "

3a Font, 85 letters.

4a " 90 "

5a " 104 "

Figures, 26 characters.

Number of each: 3 2 2 2 2 2 2 2 2 5 2
 1, 2, 3, 4, 5, 6, 7, 8, 9, 0, \$

10-LINE BUFFALO 10c. per letter

T Y P E

15-LINE BUFFALO 15c. per letter

A R

ANY SERIES OF WOOD TYPE WILL BE DELIVERED AT SHORT NOTICE

PLANERS.

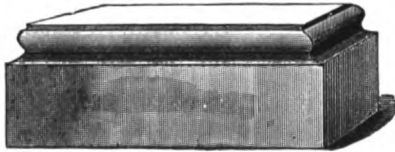

"Midget"	\$.10	Medium	\$.25
Large35	Proof Planers60
	Leather Top, extra		\$.10

MALLETS.



Small	Hickory, \$.20	Lignum Vitæ, \$.25
Medium	" .25	" " .40
Large	" .30	" " .50

WRENCHES.

6-inch	\$.50	8-inch	\$.75	12-inch	\$1.00
------------------	--------	------------------	--------	-------------------	--------

SHOOTING STICKS.



C. & M., polished steel	\$.60
The H. C. Hansen, forged steel75
Malleable Iron, enamelled25
" " Brown's Patent, plain50
Brass, Brown's Patent, polished or nickel plated75

TWEEZERS.



Made of tempered steel; file cut points. Best in the market.

A5, nickel plated. Each	\$.85
H, " " " "50
B5, " " " "75
Fine nickel plated Tweezers25
Special " "30



340. Folding Bodkin and Tweezers; a new pattern, and the best thing of the kind made. Nickel plated. Each	\$.85
B10. Tweezer and Bodkin combined "75
Tweezer and Bodkin combined "60

BODKINS.



The best needle steel is used in the manufacture of this bodkin, and it is tempered especially for the purpose. The handles are jet black, enamelled. Each \$.10

MITER BOX AND SAW.

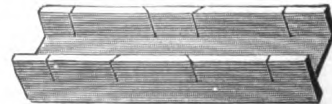

Miter Box, 10 inches long, each	\$.50
" " 20 " " " "60
Back Saw, for cutting wood or metal, 10 inch blade	1.25
" " " " " " 12 " "	1.50

PATENT TILTING BRACKET
With Galley Rest.

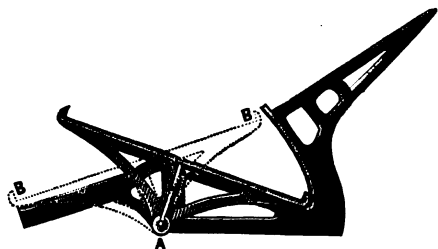

B. B. (outline) shows Bracket holding case in position for setting. Shaded cut shows Bracket tilted up, allowing compositor to empty on galley below lower case.

The use of this Bracket enables the whole top of the cabinet to be made use of to hold tied-up type, and saves time, as the compositor does not require to leave his case to empty his stick.

Price per pair, with Galley Rest \$2.00

RUCKENBROD MAILING GALLEY.



Price, Zinc bottom, each \$.75

MUSTANG MAILING GALLEY.



Price, Zinc bottom, each \$.50

ALL-BRASS RIVETED GALLEYS

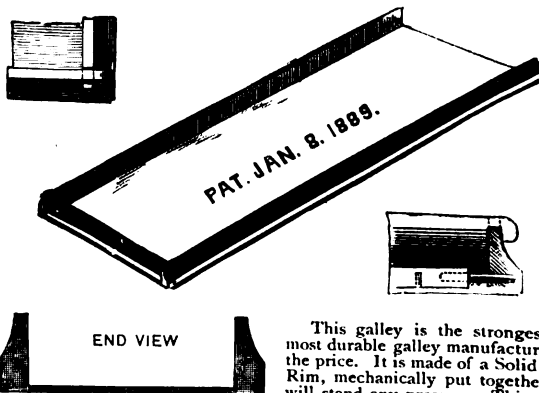

This galley is the strongest and most durable galley manufactured for the price. It is made of a Solid Brass Rim, mechanically put together, and will stand any pressure. This galley is superior to all others made with soldered or riveted rims.

JOB GALLEYS.

6x10 inside,	\$1.50
8 $\frac{1}{4}$ x13 "	2.00
9x14 "	2.50
10x16 "	3.00
12x18 "	3.75
14x21 "	4.50
15x22 "	5.00
18x25 "	6.00

NEWS GALLEYS.

Single Col. 3 $\frac{1}{4}$ x23 $\frac{1}{4}$ inside	2.00
" " 3 $\frac{1}{4}$ x15 $\frac{1}{4}$ "	1.75
" " 3 $\frac{1}{4}$ x11 $\frac{1}{4}$ "	1.50
Medium " 5x23 $\frac{1}{4}$ "	2.25
Double " 6 $\frac{1}{4}$ x23 $\frac{1}{4}$ "	2.50
" " 6 $\frac{1}{4}$ x15 $\frac{1}{4}$ "	2.25
" " 6 $\frac{1}{4}$ x11 $\frac{1}{4}$ "	2.00
Triple " 8 $\frac{1}{4}$ x23 $\frac{1}{4}$ "	3.25
Four " 10 $\frac{1}{2}$ x23 $\frac{1}{4}$ "	4.00
Five " 13x23 $\frac{1}{4}$ "	4.75
Six " 15x23 $\frac{1}{4}$ "	5.50
Seven " 17x23 $\frac{1}{4}$ "	6.00
Eight " 19x23 $\frac{1}{4}$ "	6.50

Other sizes made to order at proportionate prices.

THE CASLON SELF-LOCKING GALLEY.

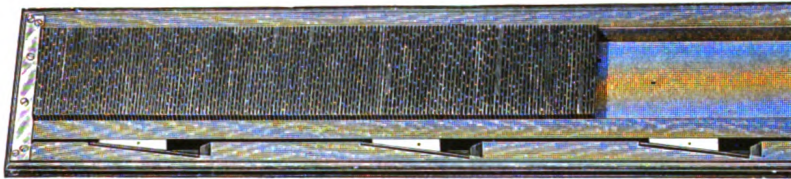

This galley lock-up is attached to the side of the galley, and constitutes the only practical lock-up on the market. It is cheap and within the means of all. It is positive in its effect and cannot get out of order. This is the only device ever offered which combines the galley and the lock-up.

Single Column, 3 1/2 x 23, inside \$2.50 Double Column, 6 1/4 x 23, inside \$3.00

FORM TRUCK.

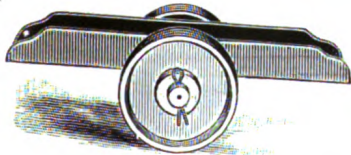

A boy can move any large type form with this Truck.

Made with steel axle that will never break.

Iron Tire \$2.50
Rubber Tire 4.00

HAND ROLLERS.



Hand Roller, 5 inches long \$.70
 " " 6 " "80
 " " 8 " "90
 " " 10 " " 1.10
 " " Adjustable, 12 to 15 inches 1.25

"SUCCESS" SAFETY BENZINE CAN.

By the use of the "Success" Safety Can, leakage of Benzine or its vapor is prevented, as the stopper is automatically self-locking — is always tightly closed when the can is not in use. The flow of Benzine, or any other fluid is regulated by the pressure of the second and third fingers upon a circular plate on the nozzle, and the adjustment is so perfect that one can pour a single drop or a full stream at will. The patent improved stopper is as durable as it is simple, and is carefully finished and adjusted. As a safeguard against loss by fire, this can is an economical and profitable "policy."



Half Pint Can \$.50
 Pint Can60
 Quart Can75
 Half Gallon Can 1.50
 Gallon Can 2.00

CLARK'S BENZINE CAN.

Pint Can \$.50 Quart Can \$.75

SCREW COMPOSING STICK, Style B.
Patent Adjustable Knee.

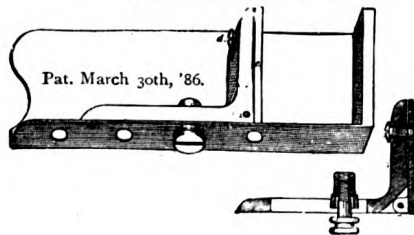

SLOT COMPOSING STICK, Style C.
Patent Adjustable Knee.

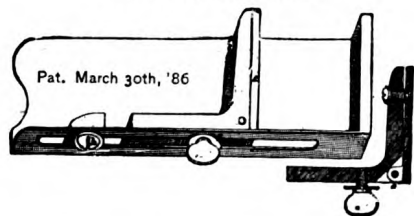

SCREW COMPOSING STICK.

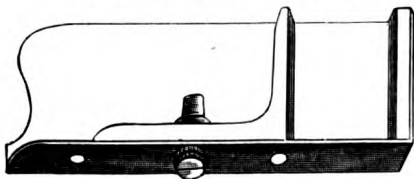

PRICE LIST.

	Screw Stick.	Style B.	Style C.
6 inch,	\$.75	\$.90	\$1.10
8 "	.80	1.00	1.20
10 "	1.00	1.20	1.40
12 "	1.15	1.35	1.60
14 "	1.30	1.45	1.80
16 "	1.45	1.60	2.00
18 "	1.60	1.80	2.20
20 "	1.75	2.00	2.40

	Union Stick.	Yankee Stick.	Standard Stick.
6 inch,	\$1.10	\$.75	\$1.75
8 "	1.20	.80	2.00
10 "	1.40	1.00	2.25
12 "	1.60	1.15	2.50
14 "	1.80	1.30	
16 "	2.00	1.45	
18 "	2.20	1.60	
20 "	2.40	1.75	

Nickel Plated Sticks.

25 cents extra on 6-8 inch Sticks.			
30 "	"	10-12 "	"
35 "	"	14-16 "	"
40 "	"	18-20 "	"

**COMPOSING
STICK RACK.**

The most convenient receptacle for Sticks. Holds twelve Sticks, any size, set to any measure. Sides are of japanned iron, attached to a varnished board.

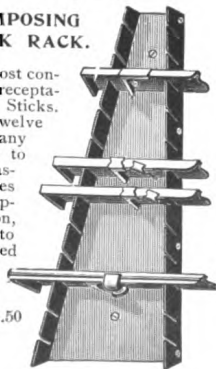

Price, \$1.50

UNION COMPOSING STICK.

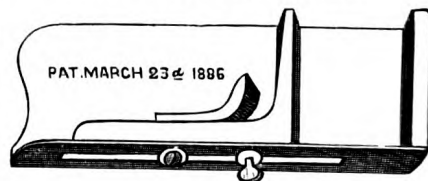

WOODEN POSTER STICKS.

24-inch	\$1.10	36-inch	\$1.40
30 "	1.25	42 "	1.60

STANDARD JOB STICK.

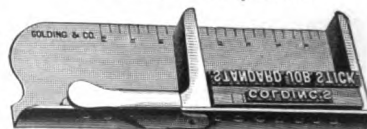

This Stick is original in its action, absolutely correct, and cannot slip. It can only be set to picas and nonpareils on the point system. Its use will result in a great saving of time and material, as every lead and rule cut for jobs set in it must be on the standard, and no carelessness on the part of compositors in setting sticks can lead to waste of material through cutting irregular measures.

YANKEE JOB STICK.

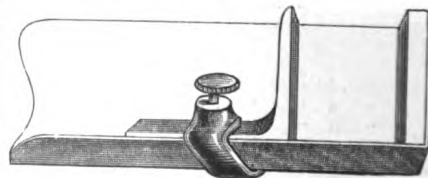

THE ROUSE JOB STICK

Quickest to Set: Most Perfect Measure: Stiffest Knee: Best Clamp: Faultless Adjustment: Unequalled Construction: Superior Finish.



Every Stick warranted.

Length, 6-inch,	Capacity, 21 Picas,
" 8-inch,	" 34 "
" 10-inch,	" 46 "
" 12-inch,	" 57 "
" 15-inch,	" 73 "

2-inch, \$1.75
2 " 2.00
2 " 2.25
2 " 2.50
2 " 3.00

THE ROUSE JOB STICK	
2¼-inch, \$1.85	2½-inch, \$1.95
" 2.10	" 2.20
" 2.35	" 2.45
" 2.60	" 2.70

Wood Poster Stick



16-in. \$1.00	18-in. \$1.05	20-in. \$1.10	
24-in. 1.20	28-in. 1.30	30-in. 1.35	
32-in. 1.40	36-in. 1.50	40-in. 1.75	42-in. 1.80

GROVER COMPOSING STICK



6-in. \$.30	8-in. \$1.00	10-in. \$1.20	12-in. \$1.40
14-in. 1.60	16-in. 1.80	18-in. 2.00	20-in. 2.20

ELM CITY NEWS STICK.

PISTOL GRIP HANDLE.

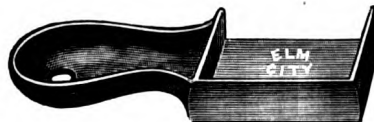

This stick has no rival for news work. Made solid to measure, there is no chance of its springing, and it can be used as the standard of the office. Being light, weighing only 6 ounces, well balanced and shaped to fit the hand, the cramping grip necessary on the ordinary stick is done away with. Made to measure in 13 and 13½ ems.

PRICE, Japanned,	\$1.00
Polished and Nickeled,	1.25

HEMPEL'S PATENT QUOIN.



No. 1 (small) per doz.
pairs \$2.50
Per pair25

No. 2 (large) per doz.
pairs \$3.00
Per pair30

Challenge Hempel Quoins, per dozen \$1.25
Keys, Nos. 1 and 2, each nickeled, 50 cts.

THE MORTON LOCK-UP.



An Iron Side-Stick with broad bearings, true and square, attached to the best machine-finished Steel Quoins. The quickest, safest and most complete lock-up. All in one piece. Placed directly against the type.

PRICES, EACH.

3½ in., 1 Quoin	\$.40
4 in., 1 "40
5 " 1 "40
6 " 1 "45
6 " 2 "70
7 " 2 "70
8 " 2 "75
9 " 2 "75

PRICES, EACH.

10 in., 2 Quoins	\$.80
12 " 3 "	1.10
13 " 3 "	1.15
15 " 3 "	1.20
18 " 3 "	1.30

KEYS.

Plain	\$.50
Polished75

WICKERSHAM'S QUOIN.



No. 2, ¾ inches wide, expands 14 points, per dozen \$2.50
Keys, each50

"MIDGET" SAFETY QUOIN.



This Quoin is specially adapted for locking up a form where space in the locking is limited, such as mortises, contents, etc.

It occupies a space of but three Nonpareils and is simple, practical, safe and effective. Just the thing for ledger headings where there is little space for the end lock-up.

Price, \$2.00 per doz.



STEEL BEARERS.

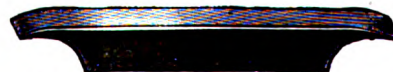

Prices per pair: For Press 5x9, 35c; 7x11, 40c; 8x12, 45c; 9x13, 50c; 10x15, 50c; 11x17, 60c; 12x18, 70c; 13x19, 75c; 14x22, 90c.

Explanation of Numbers.

No. 0, 9 points high; No. 1, 12 points high; No. 2, 15 points high; No. 3, 18 points high; each with one-sixteenth inch lip. No. 4, 12 points high with little or no lip. No. 5, 15 points high, one-eighth inch lip. No. 6, 12 points high, and No. 7, 18 points high, each with one-quarter inch lip.

HANSEN'S SOLID BRASS GAUGES.



These Gauges are preferred by many pressmen to any other kind, especially for registered color work. They are easily and quickly secured to the tympan sheet with either paste or mucilage, and will not slip. Made in 10, 12, and 18-point thicknesses, and furnished assorted if desired. Price, 5 cts. each, or 50 cts. per doz. A great improvement over the old quad gauge.

THE NEW FLEXIBLE GAUGE PIN.



The most important feature about this new gauge pin is its perfect adaption as a side gauge. It can be used directly under the gripper without injury to either. Three sizes, Nos. 1, 3, and 4. Price, 60 cts. per doz. Assorted if desired. They are invaluable for bottom gauges when running curled sheets. This cut shows the No. 1.

SCREW ADJUSTING GAUGE PIN.

One size: No. 1. Has an adjustable tongue. An adjustable gauge pin without teeth. This pin can be moved at any time to correct the position of the sheet without marring the tympan. It gives very fine adjustment.

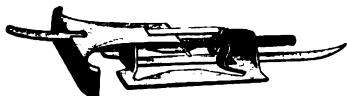

Price, \$1 per set of three, including one dozen extra tongues of different shapes. Tongues sold extra at 25 cts. per doz., either shape, or assorted if desired.

GOLDEN STEEL GAUGE PIN.



Six sizes: Nos. 1, 2, 3, 4, 5, 6. 40 cts. per doz.

ORIGINAL STEEL GAUGE PIN.



Four sizes: Nos. 1, 2, 3, 4. 60 cts. per doz.

SPRING TONGUE GAUGE PIN.



One size: No. 1. The tongue is adjustable. Price, per doz., \$1.20; per set of three, 40 cents. Including an extra tongue for each pin. Extra tongues, long or short, 25 cts. per doz.

ECCENTRIC STUD GAUGES.

Price per pair \$.50

IRON GAUGE PIN DRAWER.



A handy place for gauge pins when not in use. Price, 15 cts. each.

EXTENSION FEED GUIDES.

For gauging sheets at or below the edge of the platen.

The extension is 2 1-2 inches long and may be cut down if required.

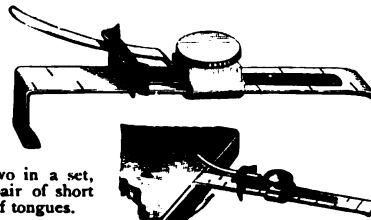

Price, \$1.00 per set, two in a set, complete with an extra pair of short guides and an extra pair of tongues.

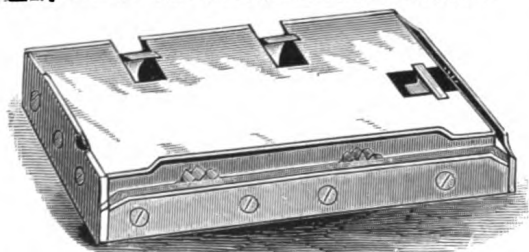
PATENTED STEREOTYPE BLOCKS.

IMPROVED PLAIN OLD STYLE BLOCK, WITH PATENT END HOOK.

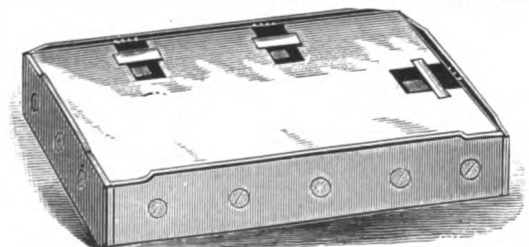

NEW STYLE BLOCK, WITH PATENT SIDE AND END HOOKS.

The above cuts represent our new Stereotype Blocks, with End Hooks, for Cylinder Presses. They are made of the best San Domingo Mahogany, thoroughly seasoned, and every part is made and fitted with the utmost care. The superior quality of material and the workmanship in these blocks, and their accuracy, is well-known; they recommend themselves.

Owing to the number of different sizes, and the uncertainty of demand, we cannot undertake to carry a full line of these blocks in stock, but are prepared to fill orders for any quantity at short notice.

In ordering Blocks state whether patent or plain, with or without end hooks, and if any additional hook is wanted. Also state size of block over all, with sizes of largest and smallest plate to be worked, measuring the plate from the back. All blocks are made $\frac{3}{4}$ inch thick unless otherwise ordered. Blocks without End Hooks are for Bed and Platen Presses, those with End Hooks are for Cylinders.

SIZES AND PRICES.

Sizes.	WITHOUT END HOOKS.				WITH END HOOKS.		
	Outside Dimensions of Blocks.	No. of Side Hooks.	Plain Old Style.	Patent New Style.	Whole No. of Hooks.	Plain Old Style.	Patent New Style.
Folio:							
Imperial	16 x 22 $\frac{1}{2}$	4	\$5.00	\$6.25	7	\$7.25	\$8.50
Sup. Royal.....	13 $\frac{1}{2}$ x 21 $\frac{1}{2}$	4	4.55	5.70	7	6.80	7.95
Royal	12 $\frac{1}{2}$ x 19 $\frac{1}{2}$	4	4.20	5.25	7	6.40	7.45
Medium.....	11 $\frac{1}{2}$ x 18 $\frac{1}{2}$	4	3.90	4.80	7	6.10	7.00
Quarto:							
Imperial	11 x 16	4	3.75	4.50	6	5.30	6.10
Sup. Royal.....	10 $\frac{1}{2}$ x 13 $\frac{1}{2}$	3	3.10	3.75	5	4.50	5.25
Royal	9 $\frac{1}{2}$ x 12 $\frac{1}{2}$	3	2.95	3.50	5	4.25	4.90
Medium.....	9 x 11 $\frac{1}{2}$	3	2.80	3.30	5	4.00	4.60
Octavo:							
Imperial	7 $\frac{3}{4}$ x 11	3	2.65	3.10	4	3.30	3.80
Sup. Royal.....	6 $\frac{1}{2}$ x 10 $\frac{1}{2}$	3	2.50	2.90	4	3.15	3.60
Royal	6 x 9 $\frac{1}{2}$	3	2.40	2.75	4	3.00	3.40
Medium.....	5 $\frac{1}{2}$ x 9	3	2.30	2.60	4	2.85	3.25
Demy	5 $\frac{1}{4}$ x 7 $\frac{3}{4}$	3	2.20	2.45	4	2.70	3.10
Duodecimo:							
Broad.....	5 $\frac{1}{4}$ x 6 $\frac{3}{4}$	2	1.65	1.90	3	2.05	2.45
Sixteen mo:							
Sup. Royal.....	5 x 6 $\frac{1}{2}$	2	1.50	1.70	3	1.95	2.30
Medium.....	4 $\frac{1}{2}$ x 6	2	1.40	1.60	3	1.85	2.15
Demy	3 $\frac{3}{4}$ x 5 $\frac{1}{4}$	2	1.30	1.50	3	1.75	2.00
Eighteen mo:							
Medium.....	3 $\frac{1}{2}$ x 5 $\frac{3}{4}$	2	1.30	1.50	3	1.75	2.00
Thirty-two mo:							
Sup. Royal.....	3 x 5	2	1.20	1.40	3	1.65	1.85

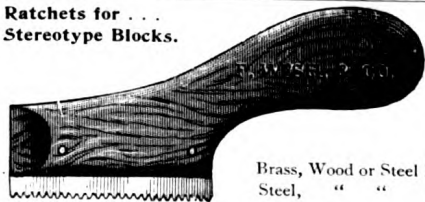
**Ratchets for . . .
Stereotype Blocks.**

These Ratchets are strongly made in Brass and Steel riveted to Wood or Steel handles.

Brass, Wood or Steel Handle \$.50
Steel, " " "75

HANSEN'S COMPLETE MITERING MACHINE

Miters any angle accurately and in much less time than any other, therefore it saves the printer from continually wasting brass rule and enables him to do better work.

Patented Jan. 20, 1903.



Price,
\$18.00

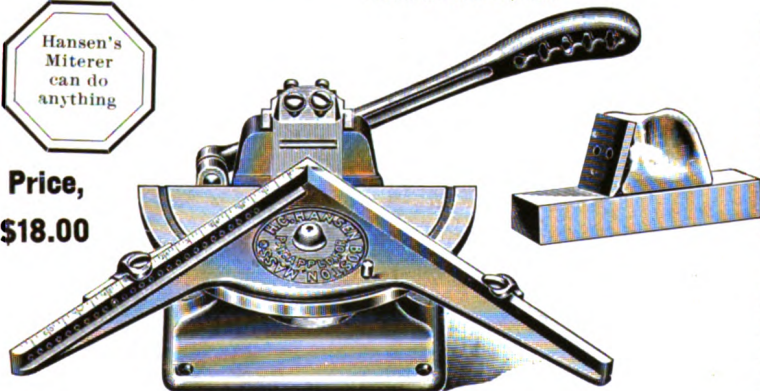

TESTIMONIALS

Homestead Job Print, Springfield, Mass.

H. C. HANSEN, Dear Sir:

April 4, 1902

After your practical but unconvincing argument in favor of your new Mitering Machine, I finally purchased one, and now I feel I owe you an apology. I was brought up on two machines, and have used two other makes, but *yours is in a class by itself*. Your method of setting the knife and the angle of the cutting edge enables the printer to do perfect mitering easily, and the gauges and methods of setting for various angles make it the nearest to perfect of any miterer yet on the market. It is not to be compared with any similar machine. Yours truly,

JOHN C. OTTO

55 Franklin Street, Boston, Mass.

H. C. HANSEN, Dear Sir:—In regard to the Hansen Complete Mitering Machine, we are very glad to state that it is "complete" as you have named it, and is undoubtedly the best Mitering Machine that has ever been produced up to date. Its advantage are so obvious that it seems only necessary to show the machine to sell it. Yours truly, THE SPARRELL PRINT, R. E. Sparrell, Tr.

ADVANTAGES OF HANSEN'S COMPLETE MITERING MACHINE

1. The rule holder has an angle of 90 degrees, when placed in a central position, you can miter square sets a lifetime without changing its position.
2. It is easily set by a pin for any desired angle, having no lines to guess at, therefore enabling the operator to obtain the required angle positively accurate at all times.
3. It is graduated by 12-Pt. ems and has two gauges, the left hand gauge having a supporter that enters any one of the holes of even ems, and by turning the supporter each quarter turn it lengthens or shortens the measure a 6-Pt. em.
4. You can get the inside measure by placing 2, 3 or 4-Pts. between the supporter and gauge.
5. The knife is held firmly by two screws and is regulated by two adjusting screws.
6. A Jointer for sharpening the knife to the proper angle is furnished with each machine. This enables the operator to always have the same bevel which is a very essential point in order to obtain a clean cut.
7. The bed is indexed, 2, 3, 4, 5, 6, 8, 10 and 12 respectively, representing the different angles for a 3, 4, 5, 6, 8, 10 and 12 sided figure, therefore doing away with lines you have to guess at.
8. The handle strikes a rubber tube which does away with noise and jar received on other machines.

HANSEN'S IMPROVED CURVING MACHINE.



This is the simplest and most practical Curving Machine in the market. It will rapidly and accurately bend Brass Rules, Leads, or Slugs into circles, ovals or curves of almost any size; it will also straighten out curved or bent pieces of Rule so that they may be used indefinitely.

The construction of this machine is simple, solid and powerful.

The curving cylinder can be easily detached, and circles, ovals, etc., taken from it without injuring their completeness. The degree of curve desired is constantly at the will of the operator.

PRICE \$15.00

TYPE-HIGH GAUGE.

This gauge saves an immense amount of time, and will enable you to put a gauge on work sent in by Electrotypers and Engravers. If electrotypes are too high or low you are forced to spend valuable time in the press room, all of which is a total loss because unnecessary.



PRICE, \$2.50

HANSEN'S COMPLETE TYPE MEASURE

Made in two sizes, of four and six inches.

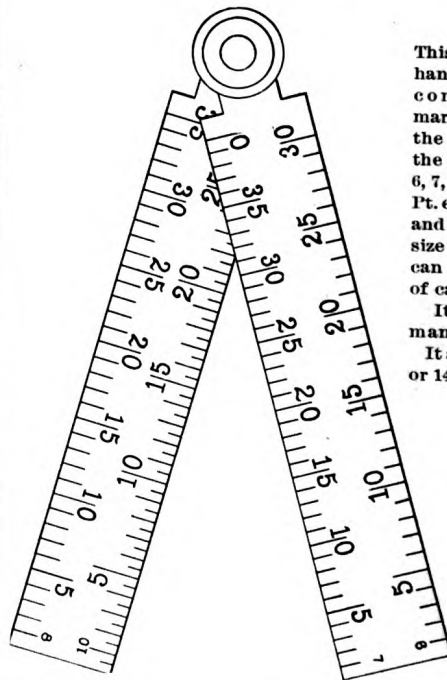

This Measure is the handiest and most complete on the market. It affords the printer to find the number of 5, 5½, 6, 7, 8, 9, 10, 11 and 12 Pt. ems in the length and width of any size pamphlet, as it can be used as a pair of calipers.

It is made of German Silver.

It also gives Agate or 14 to in. measure.

HANDY
TO
CARRY
IN THE
VEST
POCKET

Send for illustrative circular.

4-inch,	.	.	.	\$1.00
6-inch,	.	.	.	1.50



**LITTLE
GIANT
RULE & LEAD
CUTTER**

Sizes and Prices.

No. 1, gauges 12-in.
\$7.00

" 12, " 12½ in.
back, 11½ in front
\$10.00

THE "C." & M LEAD CUTTER.

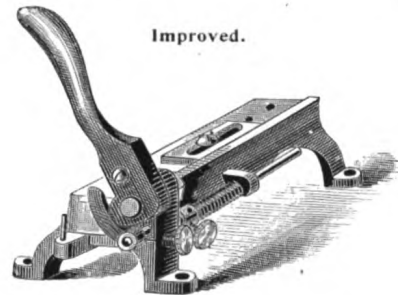

This is one of the best and cheapest Lead Cutters in the market. It is well and strongly made, and will not get out of order. The No. 2 has a front gauge, which allows the operator to cut short lengths rapidly and accurately.

No. 1, single gauge, cuts to 48 picas \$2.00
No. 2, double gauge, cuts to 60 picas 3.50

Copper

Brass

Metal

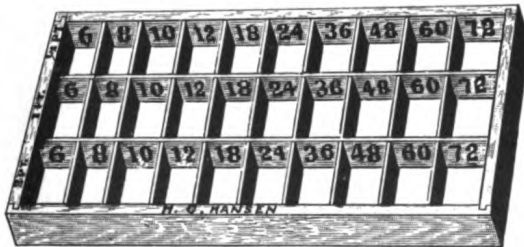

ASSORTED CASE OF THIN SPACES

Cut accurately in ten sizes from 6 to 72-Pt. and three thicknesses, ½, 1 and 2-Pt.

The various thicknesses can be easily distinguished by the different kinds of metal.

½-point is made of Copper, 1-point Brass, and 2-point Metal

The case will fit in a full size blank case with other quarter cases. Thin Spaces of any size are sold separately at 25 cents for 2 ounce package. Any size or sizes cut to order at \$2.00 per lb.

PRICE, Complete with Case, \$5.00

New Type Cases

We show here some new ideas in cases. These have special merits individually and they are not freaks designed just for the purpose of introducing something new. These cases are useful to every printer and a great time-saver. The line of type cases is large, and is not added to unless there is an urgent demand for their sale.

COMBINATION JOB CASE



Designed especially for use in legal blank and similar work. Cap side same as California job. Holds brass leaders from 1 to 16 ems, including half ems from 1 to 5. This case will take a 25-lb. font of type and a 10 or 12-lb. font of brass leaders easily. The use of this case will save 50 to 75 per cent. of the compositor's time in legal blank and similar composition. Price, \$1.20.

DEARING ACCENT CASE



Will take care of all the accented letters with which printers under ordinary circumstances ever come in contact. It is divided into five sections, for caps, small caps and lower-case of Romans, and caps and lower-case of Italics. It has extra boxes for Spanish, French and Portuguese accented letters. Price, \$1.50.

PRACTICAL SPACE AND QUAD CASE



Many offices have the spaces and quads separated from the job type, a new space and quad case has become a necessity. This case provides for $\frac{1}{2}$ and 1 point spaces without the necessity of mixing. Each case will accommodate seven sizes of spaces and quads. The compartments are large. Price, \$1.10.

TYPE CASES

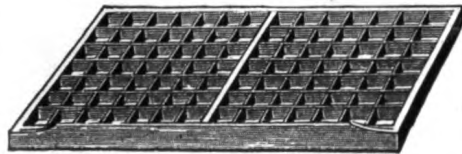

UPPER CASE

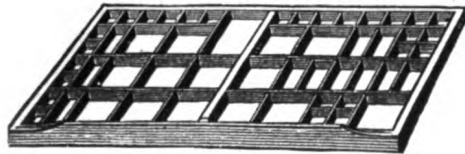

LOWER CASE.

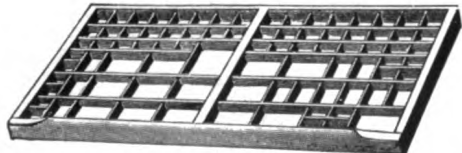

YANKEE JOB CASE.

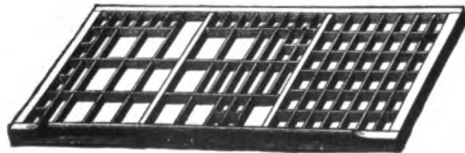

ITALIC OR JOB CASE.

PRICE LIST OF CASES

Full Size.

News, per pair	\$1.60
" " " Pat. clasp	1.75
Italic or Job90
" " " Pat. clasp	1.00
New York Job	1.00
Yankee Job	1.00
Improved Job	1.20
California Job90
Dearing Job Case,	1.00
" " " Pat. clasp	1.00
Triple90
" " " Pat. clasp	1.00
Space and Quad	1.00
Labor-saving Lead	1.00
Blank65
Figure	1.00
Metal Furniture, single depth	1.50
Metal Furniture, double depth	2.00
Wood Type, 23X32 1/4 in.	1.00
Mammoth Wood Type, 23X44 in.	1.30
Wells' Rule Case, No. 2	1.25
" " " No. 3	1.30
Butler Job per pair	3.00
Bettis Lead Case No. 1, for leads 4 to 28 em.	4.50
Bettis Lead Case No. 2, for leads 30 to 60 em.	4.50

Three-Quarter.

News, per pair	1.50
" " " Pat. clasp	1.60
Italic or Job85
" " " Pat. clasp90
Yankee Job85
Blank60

Two-Third.

News, per pair	1.40
" " " Pat. clasp	1.50
Yankee Job75
" " " Pat. clasp80
Improved Job90
Labor-saving Rule90
Blank45
Wood Type90

TYPE CASES



NEW YORK JOB CASE.

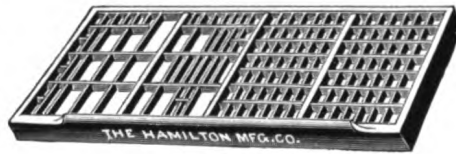

IMPROVED JOB CASE.

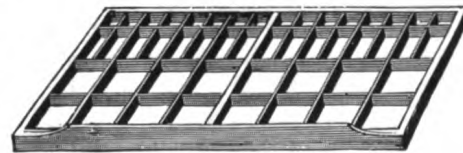

SPACE OR QUAD CASE.

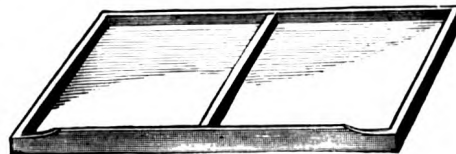

BLANK CASE.

THE HARRIS PATENT RULE CASES.

Case No. 1.

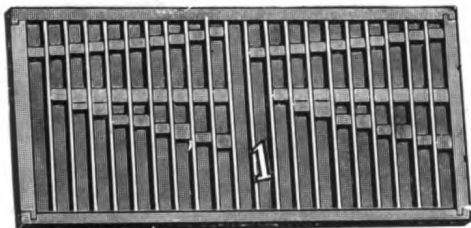

Case No. 2.

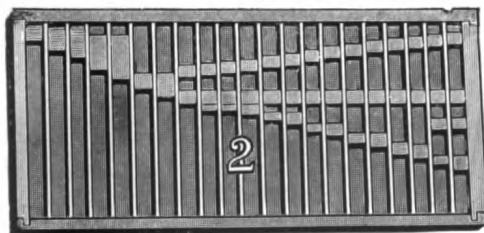

Case No. 4.

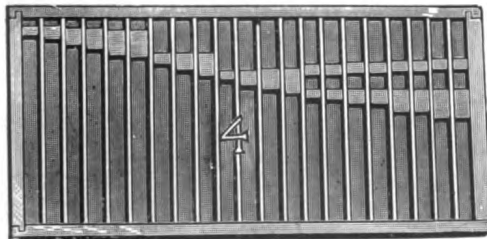

These cases are strictly in the line of economy, and they are the first, and in fact the only original scheme for rule cases that has ever been offered. They afford a most radical change in the manner of keeping fonts of brass rule, and are so varied in size and design as to furnish appropriate cases for every size of font, from eight lbs. upward. The Harris rule cases are made to fit an ordinary blank case, so that a blank case containing four of them may be shoved into a frame with job cases, or set on top like other cases. **Case No. 1** is made double, and will hold two complete fonts of labor-saving rule of 8 pounds each, or a total of 16 pounds in the case. **Case No. 2** is of the same dimensions as Case No. 1, and like it holds 16 pounds of rule—all of one font or kind. **Cases Nos. 3 and 4**, each of the same dimensions as the Nos. 1 and 2 sizes, are intended to be used together as one case, and will hold 32 pounds of rule. These cases being small and compact they can be taken from the blank case and placed in front of the compositor on his small cap case when he has a job of rule work, saving him many a walk and much annoyance each day going back and forth to the regular rule case.

PRICE LIST.

Case No. 1	\$1.25
“ “ 2	1.00
“ “ 3	1.00
“ “ 475

The Harris Rule Cases can be seen at our salesroom, and printers are invited to call and examine them. Without doubt, they are a great improvement.

PERFECTION RULE CASE.

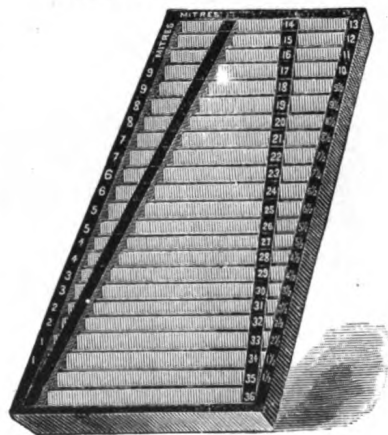

Will hold about twenty pounds of labor-saving brass rule, and has a separate place for every length by half-picas from 1 to 9½ and by picas from 10 to 32. It has a double space for lengths below ten picas. Four fit in a blank case.

Price, each \$.90

Case No. 3.



Labor-Saving Rule Case.

One of the best labor-savers is the new Compact Rule Case, made as illustrated here. It takes in all different lengths of labor-saving rule from one to thirty-six ems in length, with half picas up to ten line, having a separate compartment for each length and also for mitered corners.

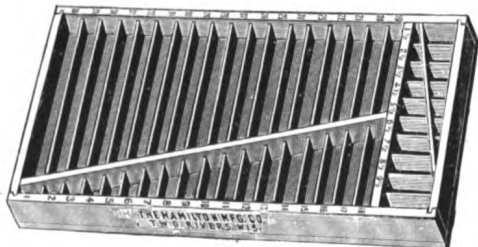

Holds 18 pounds Labor-saving rule.
Compact Rule Case No. 3. Price, 90 cents.

The two-third Yankee Job Case

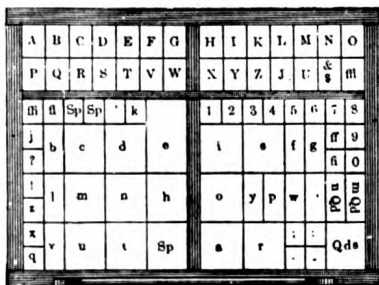

PRICE, 75 cents.

**SANSPAREIL - - - HARRIS
RULE CASE**

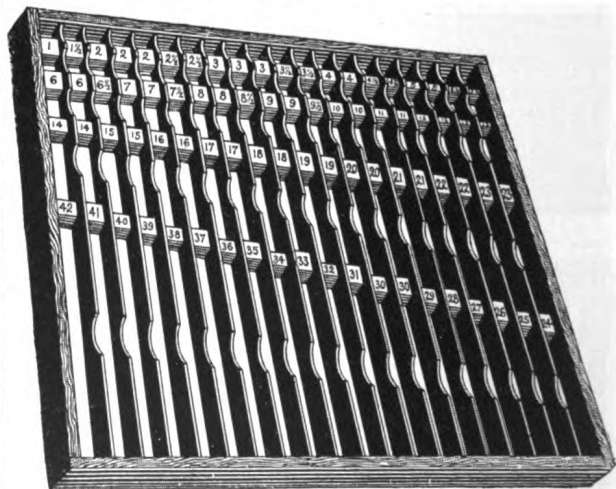

It surpasses all other Cases

*It Protects the Rule.
Rule cannot fall flat.
Is easy to extract.
Each Case Complete.
Is a convenient size.
Capacity is large.
It is durable.*

**Embodies all the
Possible
Good Features
In a Rule Case**

Price, \$1.50

Holds 30 lbs. L. S. rule.

WISCONSIN COMBINATION "QUARTER" CASE.

"Quarter Cases are the same size as and may be used in combination with Harris Rule Cases

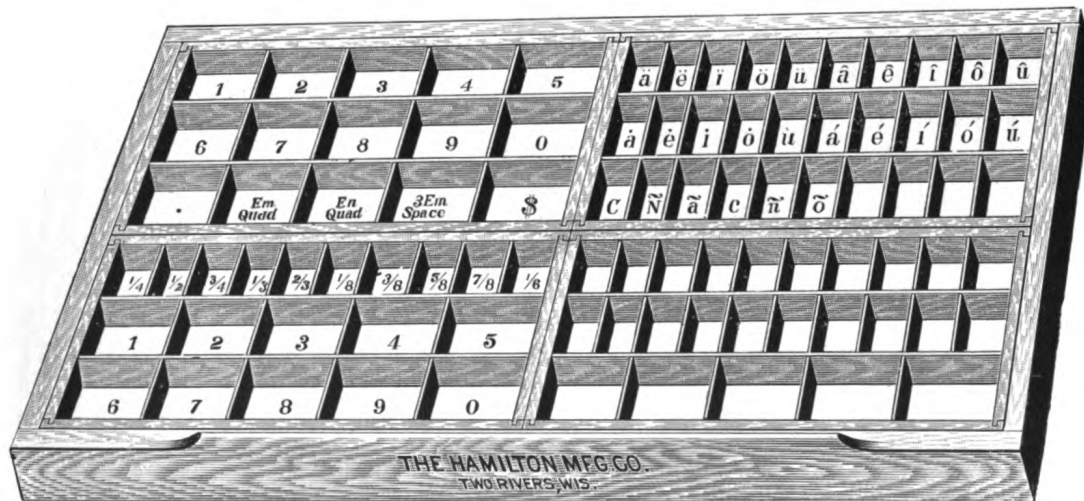

Four Wisconsin "Quarter" Cases in Full Sized Blank Case.

Quarter Case No. A, for Figures, etc., 65 cents.

Quarter Case No. C, for Figures and Fractions, etc., 65 cents.

Quarter Case No. B, for Accents, Split Fractions, etc., 65 cents.

Quarter Case No. D, for Signs, Borders, etc., 65 cents.

Per Set of Four, in regular full size, Blank Case, \$3.25

"Quarter" Cases supply a means of keeping these valuable sorts where they can be found. They can be placed on a cap case, on a stand, or on the stone, convenient to hand of compositor. In setting mathematical work, foreign languages, dictionaries, special catalogues, etc., these "Quarter" cases will prove invaluable to the printing trade.

CABINETS.

**WISCONSIN WINDOW CABINET.**

Specially designed for placing in front of a window, as it does not obstruct the light, of which the cases on top get the full benefit. Two men may work undisturbed at the sides, while the job cases in front are convenient for other men. The top is flat, and is useful for holding tied-up type.

Price, with 18 full size Cases, two pair News Cases on top. \$36.00

**FLAT AND GALLEY TOP CABINETS.**

	Flat Top.	Galley Top.
With 12 Two-third Job Cases	\$15.00	\$18.00
“ 16 “ “ “	18.00	21.00
“ 20 “ “ “	21.00	24.00
“ 12 Three-quarter Italic Cases	18.00	21.00
“ 16 “ “ “	22.00	25.00
“ 20 “ “ “	26.00	29.00
“ 12 Full Size Italic Cases	22.00	25.00
“ 16 “ “ “	26.00	29.00
“ 20 “ “ “	30.00	33.00

Porter Steel Run Cabinet No. 2

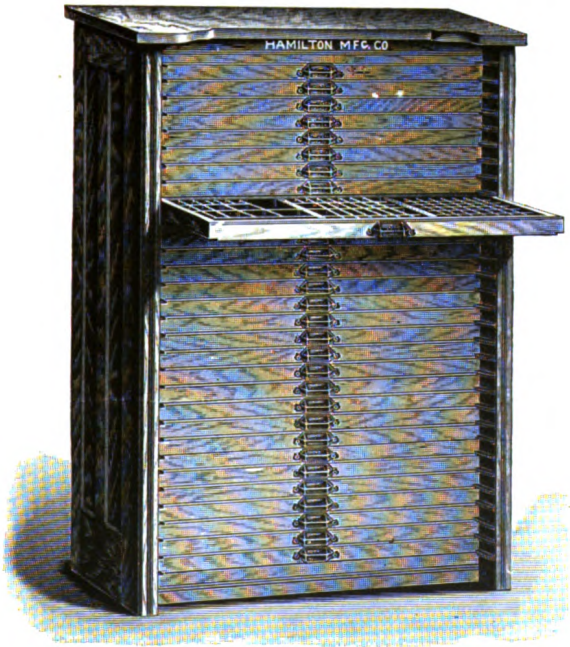

Filled with "New Departure" Cases

The merits of these Cases are well known. They ride upon the side rails only, and the bottoms do not come in contact with the case runs.

COMBINED with all the excellent features of other Steel Run Cabinets, the Porter Cabinet has the improved Steel run and the Extension Front, allowing any case to be drawn and placed at any convenient height, without using another case as a rest. The depth of the Extension Front is 4 inches. As these Cabinets are fitted in the 23 Case and 46 Case sizes, with the Patented Tilting Brackets, they can be attached so that the News Cases on top are on the opposite side from the Job Cases, thus acquiring the distinctive and valuable feature of the Polhemus Cabinets. The option is given purchasers of having Cabinets fitted with the regular Job Case or the California Job Case. Unless otherwise stated, all Cabinets are now filled with California Job Cases.

Price List of Porter Cabinets

No. 1.	25 Cases, Single Tier, Flat Top,	\$43.00
" 2.	30 " " " " " "	51.00
" 3.	40 " " " " " "	68.00
" 4.	50 " (Single or Double Tier), Flat Top	85.00
" 5.	60 " " " " " "	100.00
" 6.	23 " Single Tier, with 1 pair Tilting Brackets and 1 pair News Cases on Top	45.00
" 7.	46 " Double Tier, with 2 pr. Tilting Brackets and 2 pair News Cases on Top	90.00
" 8.	25 Blank Cases, Single Tier, Flat Top	38.00
" 9.	30 " " " " " "	45.00
" 10.	40 " " " " " "	60.00
" 11.	50 " " (Single or Dbl. Tier) Flat Top	75.00
" 12.	60 " " " " " "	90.00

Bellows

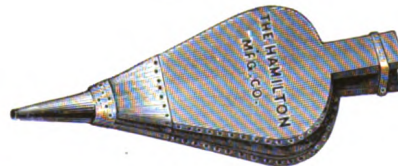

Small size, . . . \$1.00 Large size, . . . \$1.25

Wood Type Cabinets and Cases



These Cabinets furnish the most economical method of keeping wood type. The type is preserved and kept free from dust, and at the same time every letter is available without disturbing others. The No. 6 Cabinet shown above occupies but 9 square feet of floor space and affords 140 square feet of case surface for the storage of wood type.

No.	Cases	Dimensions	Flat Top	Galley Top
No. 1.	12 Cases,	23 x 32 inches,	\$24.00	\$27.50
" 2.	16 "	23 x 32 "	30.00	33.50
" 3.	20 "	23 x 32 "	36.00	39.50
" 4.	12 "	23 x 44 "	30.00	34.00
" 5.	16 "	23 x 44 "	40.00	44.00
" 6.	20 "	23 x 44 "	48.00	52.00

The "Wells" Long Wood Quoins

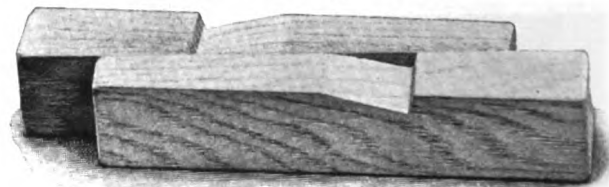

These Quoins are improved by a Top Notch, which greatly assists in unlocking the forms. They are made in four sizes, all working in pairs with straight furniture.

No.	Box of 100 Quoins,	Hickory,	Boxwood,
" 5.	" 100 "	.75	\$1.10
" 3.	" 100 "	1.10	1.75
" 4.	" 100 "	1.10	1.75

Twentieth Century UNIT TYPE CABINETS.

PRICE LIST

Unit A, 10 cases of various depths,	\$17.50
Unit B, 8 cases, 7 of regular depth,	\$15.00
Unit C, 8 blank cases for electrotypes,	\$13.00
Unit D, 8 indexed electrotypes cases,	\$16.00
Cap Piece, Style A, plain,	\$3.00
Cap Piece, Style B, drawer and 60 sort boxes,	\$7.50
Base Piece,	\$1.50

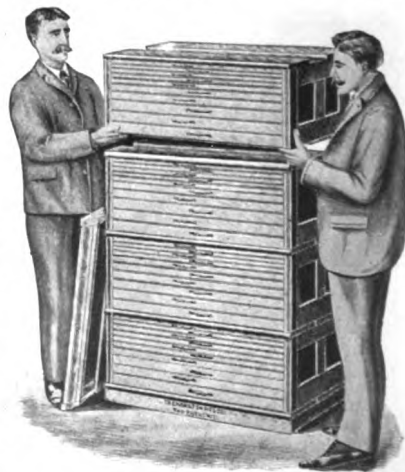

Double Polhemus Cabinet No. 1

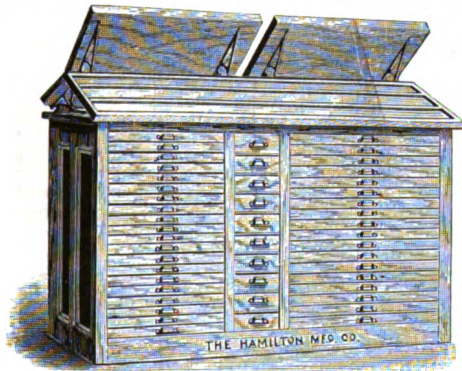

Showing Sort Drawers, Galley Top, and Job Cases. These Cabinets are also furnished Galley Cabinet instead of Sort Drawers, if preferred, at same price. 18 full size Cases, 20 two-third Cases 2 pairs of News Cases and 2 pairs of Hamilton's Patent Tilting Brackets on top, full length Galley Dump, and Sort Drawers or Galley Cabinet. \$75.00
 No. 5. Containing 25 two-third cases and 25 full cases, (steel runs) including the above, \$95.00

Leader Boxes

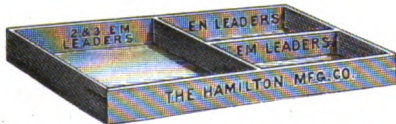

Just "the thing" for holding leaders. This size is 5 x 8 x 1 3/4 inches. Requires one for every size of body type in the office.
 Hamilton Leader Box, per doz., \$2.50 Each, 25c.
 Large size, " " 5.00 " 50c.

Handy Letter Board Cabinets

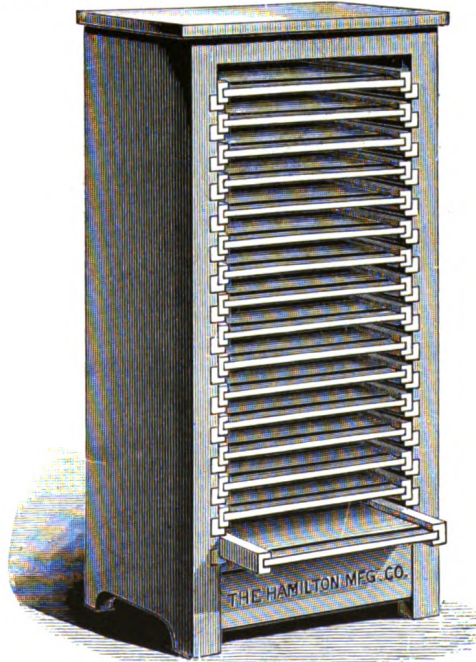

For job work these Cabinets are unrivaled. They will save their cost in a few months by preventing "pi" alone. They occupy a floor space of 16 x 19 inches, with Letter Boards of 12 x 15 inches inside, and are made of hardwood throughout. Boards are closed at sides and back, and are rabbeted in front to receive galleys.
 Cabinets with 10 Boards, \$10.50 12 Boards, \$12.00
 16 Boards, \$15.00

CASE STANDS AND RACKS.

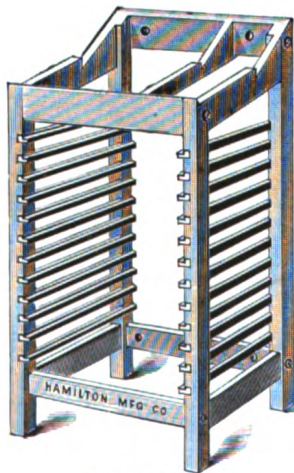

Single Stand.

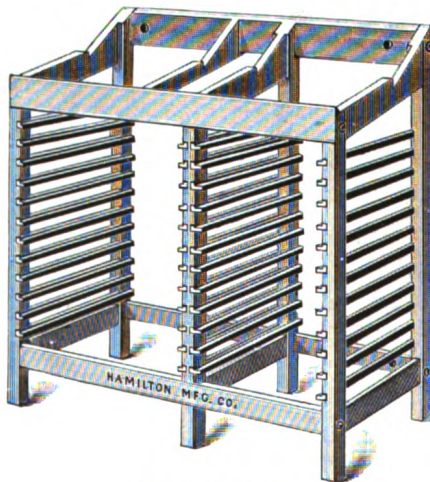

Double Job Stand.

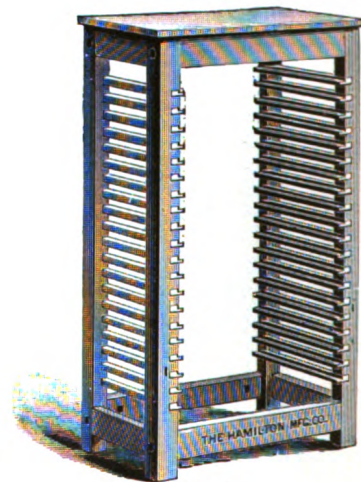

Case Rack.

PRICE LIST OF STANDS.

These Stands are put together with bolts, so that they can be taken apart and set up readily, for convenience in packing and shipping.

No. 1.	Single Stand, without racks,	\$3.75
No. 2.	Single Stand, with racks for 12 two-third cases,	4.50
No. 3.	Single Stand, with racks for 8 full size cases	4.00
No. 4.	Single Stand, with racks for 12 full size cases.	4.50
No. 5.	Double News Stand, without racks,	4.25
No. 6.	Double News Stand, with racks for 8 full size cases,	4.50

PRICE LIST OF STANDS.

No. 7.	Double News Stand, with racks for 10 full size cases,	\$5.00
No. 8.	Double News Stand, with racks for 12 full size cases,	5.50
No. 9.	Double Job Stand, with racks for 8 full and 8 two-third cases,	5.25
No. 10.	Double Job Stand, with racks for 10 full size and 10 two-third cases,	5.50
No. 11.	Double Job Stand, with racks for 12 full size cases and 12 two-third cases,	6.00
No. 13.	Double Stand, with galley rest and racks for 16 full size cases,	6.25

Other styles of Stands and Cabinets furnished to order.

PRICE LIST OF CASE RACKS.

Case Racks for 12 full size cases,	\$6.00
Case Racks for 16 full size cases,	7.00
Case Racks for 20 full size cases,	8.00
Case Racks for 24 full size cases,	9.00
Case Racks for 30 full size cases.	10.00

**New York
Double and Quadruple Stand.**

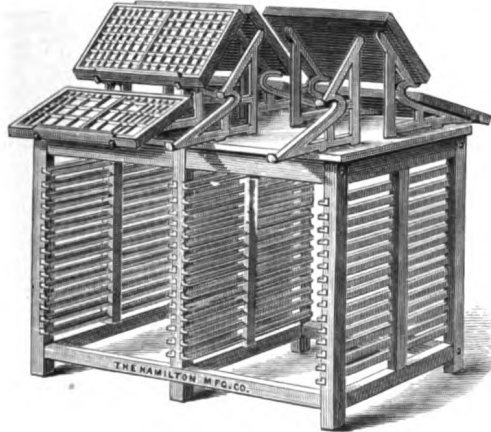

New York Quadruple Stand.

The lower cases project into the alley several inches, affording the compositor ample leg room and allowing him to get closer to the type. The angle of the lower case is just right for rapid setting. The upper case is raised above the lower and brought forward closer to the compositor's hand. The cases are held on very strong iron brackets, securely screwed to a hardwood top.

A Double Stand holds 30 cases and 2 pairs of news cases on top. A Quadruple Stand holds 60 cases and 4 pairs of news cases on top.

PRICE LIST, INCLUDING BRACKETS.

New York Double Stand, with racks for 30 cases and 2 pairs on top,	\$10.50
New York Quadruple Stand, with racks for 60 cases and 4 pairs on top,	18.00

THE POLHEMUS STANDS.

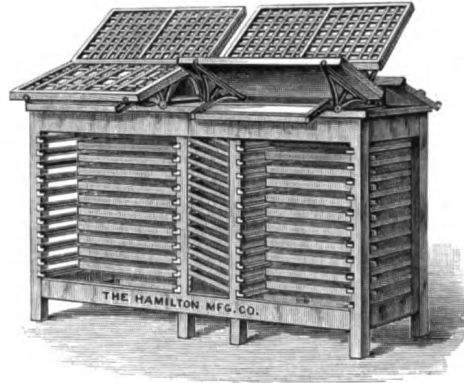

Double Polhemus Stand No. 2.

The Polhemus Stands have all the features of the ordinary stand, combined with all the conveniences of the Polhemus Cabinets. Contains a galley rack between the two tiers of cases. It is provided with the Tilting Brackets. The compositor works on the opposite side from the job cases, and a standing galley is arranged over the job cases.

PRICE LIST OF STANDS.

No. 1. Single Polhemus Stand, with racks for 12 full-size Cases, and one pair Patent Tilting Brackets on top,	\$ 7.50
No. 2. Double Polhemus Stand, with racks for 24 full-size Cases, and no Galley Rack, and two pairs patent tilting brackets on top,	13.00
No. 3. Double Polhemus Stand, with racks for 12 full and 12 two-thirds cases, and with galley rack, and two pair patent tilting brackets on top,	20.00

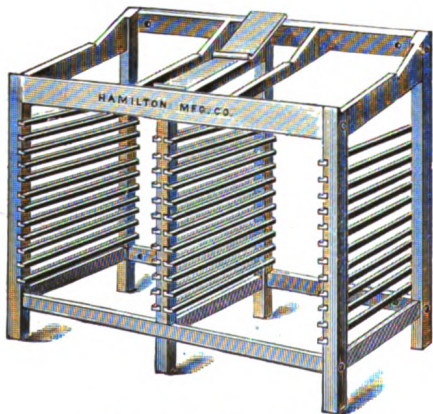

Double Stand with Galley Rest.

Double Stand No. 14, with galley rest, for 20 full size cases \$6.50
 " " " 15, " " " 24 " " " 6.75

CITY STANDS.

The upper case in these Stands projects forward over the lower case, bringing it nearer the compositor, who sets caps with greater ease than from the ordinary stand. Under the lower case there is a shelf to hold a galley, and the lower case may be pushed back (see cut) as far as necessary to permit emptying type on the galley without leaving the stand.

The Single City Stands are made to hold 15 full size cases and the Double City Stands to hold 30 full size cases.



Double City Stand.

Double City Stand, with racks for 30 full size cases \$9.50
 Single " " " " " 15 " " " 6.50

Elm City Counter



Counter, 1000, . . . \$ 7.00 Counter, 10,000, . . . \$ 8.00
 " 100,000 . . . 10.00 " 1,000,000 . . . 12.00

This Counter is made of brass, and is the strongest and most compact counter on the market.

Cylinder Press Counter

Counts
 100,000 . . \$6.00

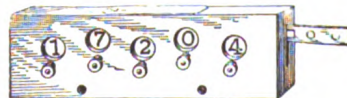

Job Press Counter

No. 1 counts 10,000
 Size 1 3-4 x 4 1-4 \$3.00
 No. 2 counts 100,000
 Size 1 1-4 x 5 3.25

Attachments for putting on to work with throw-off for Gordon Presses, 50 cents

Square Leg Table and Stone

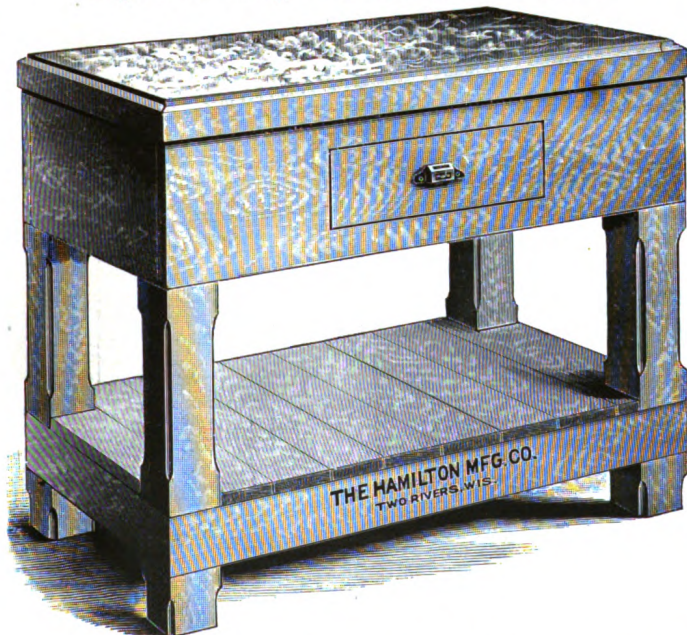

All these Imposing Frames are made of hardwood in knock-down form. This insures convenience in handling, and large frames can be taken up stairways and through narrow doors.

Frame and Marble Stone Complete

24 x 36	\$15.00	26 x 44	\$18.00	28 x 50	\$21.50
30 x 60	25.50	26 x 76	27.00	28 x 80	32.00
30 x 90	38.00	36 x 60	32.00	48 x 60	40.00

Marble; \$1.00 per square foot.

INK SLABS. 6x9, 50c. 8x12, 75c. 10x15, \$1.00 12x18, \$1.50

Ink and Roller Cabinet



A very necessary article of printing office furniture. The use of it will result in a saving of ink and rollers, which will speedily pay for the cost of Cabinet.

No. 1. Shelf for ink, shelf for brayer and ink slab, and brackets to hold 6 eighth and 6 quarto rollers.

Weight, 75 pounds, \$6.50

No. 2. Shelf for ink, shelf for brayers and ink slabs, and brackets for 6 each eighth, quarto and half medium rollers. Weight, 100 pounds, \$9.50

No. 3. Shelf for ink, shelf for brayers and ink slabs, and brackets to hold 12 each eighth, quarto and half medium rollers. Weight, 135 pounds, \$13.00

ELECTRO CABINETS.

	Flat Top	Galley Top
No. 1 12 two-third cases,	\$12.00	\$15.00
No. 2 16 " "	14.00	17.00
No. 3 20 " "	16.00	19.00
No. 4 12 three-quarter cases,	15.00	18.00
No. 5 16 " " "	18.00	21.00
No. 6 20 " " "	21.00	24.00
No. 7 12 full size cases	19.00	22.00
No. 8 16 " "	22.00	25.00
No. 9 20 " "	25.00	28.00

Illustration same as Cabinet cut shown on page 222

EUREKA LEAD RACK.

This is a good low-priced Rack, substantially constructed, in two sections, each holding lengths for 4 to 28 ems, varying by ems. One section may hold leaders, the other slugs or reglet.

Price \$2.50

ANNEX TYPE BOX.

This is a brass cup which can readily be attached to the boxes of the lower case. They are used for holding leaders, fractions, and other sorts which may be required in special jobs.

Each \$.20
Per dozen 2.25

WOODEN GALLEYS.

8 x 10 and 8 x 12 \$.40
10 x 1555
12 x 18, 8 x 24 and 10 x 2480

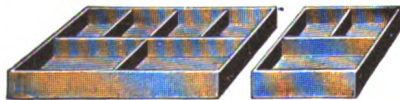
SORT AND LEADER BOXES.

Sort Box, 8 x 10 x 1 1/4 \$.35
Leader Box, 5 x 8 x 1 1/425

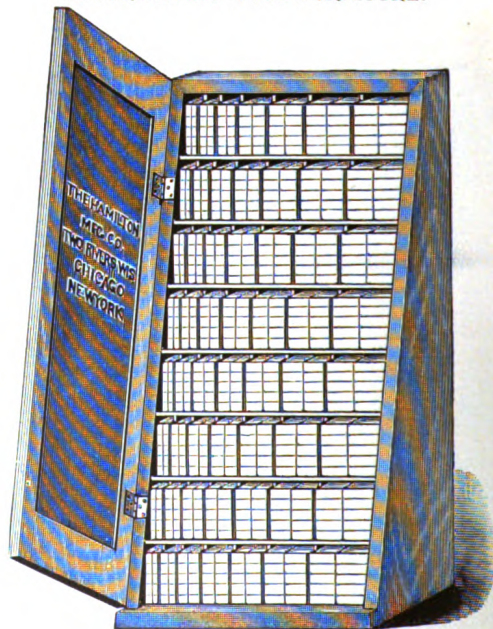
LABOR-SAVING WOOD FURNITURE.**PRICES—Including Cases.**

2 TO 12 PICAS WIDE, 10 TO 60 PICAS LONG.

No. 1—Half case, 280 pieces with partitions \$ 6.00
No. 2 " " " without partitions 5.00
No. 3—Full " 560 " with partitions 10.00
No. 4 " " 560 " without partitions 8.00
No. 5—Double " 1120 " with partitions 18.00
No. 6— " " 1120 " without partitions 15.00

The above prices include doors on cases.

No. 7 Mammoth Labor-Saving Furniture Case, containing 1,530 pieces of furniture from 2 to 10 ems wide, and from 10 to 160 ems long . 40.00

If you don't see what you want in this Catalogue, write for it.

TWO-TIER LEAD RACK.

In this Rack leads and slugs will not pi. There are compartments to take leads from 4 to 12½ by ems, and from 13 to 60 by ems. Each compartment is plainly numbered. The Rack is made in a superior solid style, and the compartments are 8 inches high. Will hold 750 pounds of leads or slugs.

Price \$6.50

LABOR-SAVING REGLET CASE.

Case No.	Quantity	Length (picas)	Case and Reglet	Reglet Only
1	1800	10 to 60	\$10.00	\$6.00
2	2400	10 "120	18.00	12.00
3	4200	10 " 51	18.00	11.00
4	2100	10 " 51	11.00	5.50
5	6300	10 "150	45.00	30.00
6	3150	10 "150	27.00	15.00

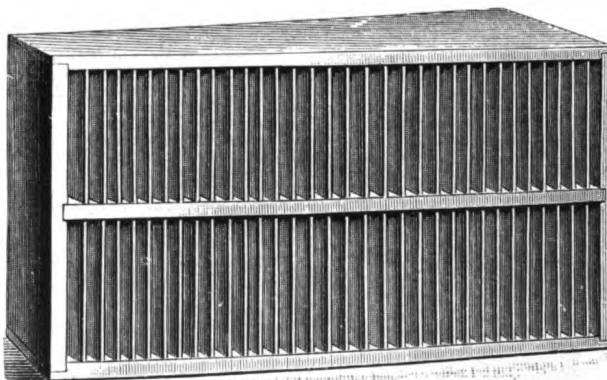

Two-Tier Lead Rack.

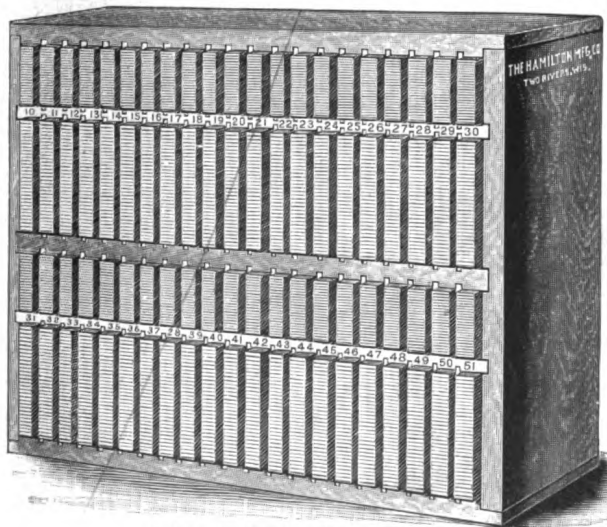

Labor-Saving Reglet Case No. 4.

BOSTON LEAD RACK.

For the printer who desires to have "a place for everything and everything in its place," these Racks are indispensable. They are made in four sections, from 4 to 60 ems pica, as shown in the accompanying cut, with length of leads plainly stamped on the top of each compartment. Each of the Racks are 16 inches long and 6¼ inches high.

No. 1	holds 4 to 15 ems	. . \$.90
" 2	" 16 to 30 "	. . 1.20
" 3	" 31 to 45 "	. . 1.50
" 4	" 46 to 60 "	. . 1.80
Set of Four	 5.00

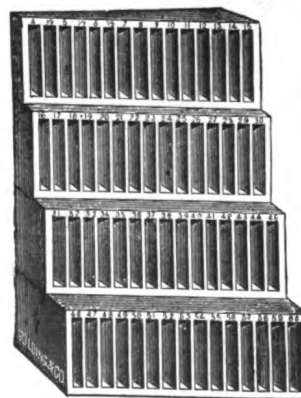

Boston Lead Rack.

PATENT INTERLOCKING DRYING RACK.

With these Racks sheets are taken direct from the fly, and may be stacked ceiling-high, in a perfectly straight and rigid pile, which cannot be knocked over by accident, and with no more weight on the bottom than on the top sheets. The pile is a most effective drying room, occupying only the floor space of one rack, and from the time the sheets are fed until they are ready for shipment they need not be handled. The interlocking device, which makes the pile straight and rigid, is shown in the cut below. Each Rack will slide with ease on the one immediately below it. They save handling, all the time of that operation, and the consequent waste of paper through offset and finger marks. In many cases these Racks save expensive slip-sheeting. They circumvent electricity, by receiving the sheet direct from the fly. They ensure evenness of temperature, and thereby assist in getting a perfect register on lithographic work. They are made with hardwood sides, wide softwood slats, and are very strongly put together.

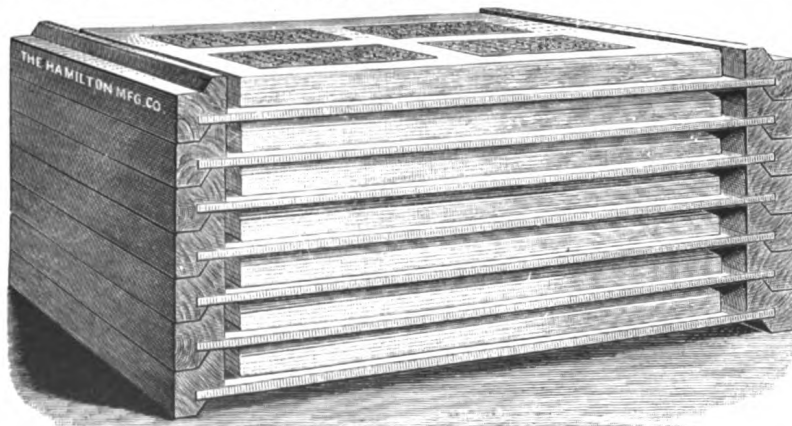
**Patent Interlocking Drying Rack.**

PRICES, EACH.

8 $\frac{3}{4}$ x13 inches, inside, and under	\$.20	18x25 inches, inside, and under	\$.40
11x17 " " " "25	24x36 " " " "50
13x19 " " " "30	32x48 " " " "60
15x21 " " " "35	38x52 " " " "65

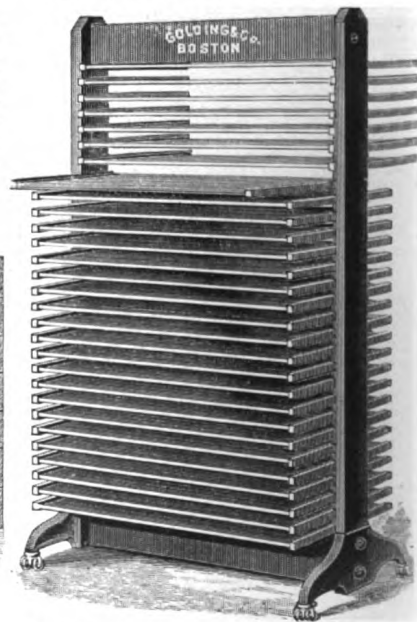
MOVABLE DRYING RACK.

This Rack is a very economical arrangement for holding paper direct from the press, and saves money, time and stock.

It occupies a floor space of only 2x3 $\frac{1}{2}$ feet, and is mounted on castors so that it may be easily placed in the most desirable position for receiving work from the press, or it may be rolled to a warm place or to the window for quick drying.

No. 1, 20 Dryers . \$15.00 No. 2, 30 Dryers . \$19.00
 Dryers, per dozen \$4.80

LEAD AND RULE MEASURES.

Divided into Pica ems, point system, and has ens cut to 10 picas. Nickel-plated.

Price, each \$1.00

Type Measures made to order.

FLAT TOP GALLEY CABINETS.

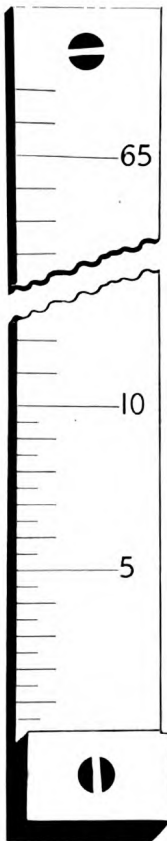

LEAD OR RULE MEASURE.

PRICES.

For 20 Galleys 1 tier	\$ 8.00
“ 30 “ 1 tier	11.50
“ 40 “ 2 tier	15.00
“ 60 “ 2 tier	22.00

AGATE MEASURES

14 to inch } 100 Agate	\$1.25
} 200 “	2.50

RULE FILES.

Price \$.15

BENZINE AND LYE BRUSHES.

Benzine Brush, 2½ x 5, fine Goats' hair	\$.50
“ “ 2½ x 5, extra quality bristles50
“ “ 1 x 5, long handle30
Lye Brush, 2½ x 825
“ “ 2½ x 5, extra quality50
“ “ 2½ x 8, all bristles75

BRASS LABEL-HOLDERS.

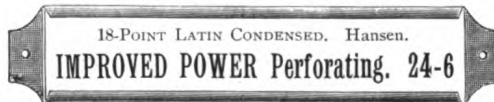

Price per hundred, complete, size 1x5½ inches, with cards and tacks, \$2.75

COPY HOLDERS.

Young's Copy Holder	\$1.00
Novelty Copy Holder25
Weinschenk's Copy Holder75

COPY HOOKS.

Price, each \$.15

BRASS TAKE SLUGS.



Price, each \$.15

ELECTROTYPED TAKE SLUGS.



Price, each \$.10

CYLINDER PRESS TAPE.

We carry Cylinder Press Tape in rolls of various sizes.

HAND PUNCHES.

Hand Punches, for punching Ball Orders, etc. \$1.25

PUBLICATIONS.

The Inland Printer, 25c. Yearly, \$2.50 International Printer, 25c. Yearly, \$2.50
 National Printer Journalist, 20c. Yearly, \$2.00
 American Printer, 20c. Yearly, \$2.00 The Printing Art, 35c.

BRASS OIL CANS.

No. 1, 10c. No. 2, 15c. No. 3, 20c. No. 4, 25c. No. 5, 30c. No. 6, 35c. No. 7, 40c.

Yearly subscriptions taken for all publications.

Folio Chase.

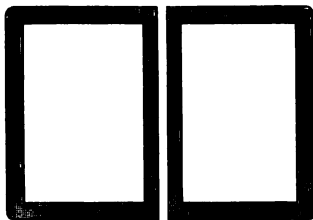

Quarto Chase

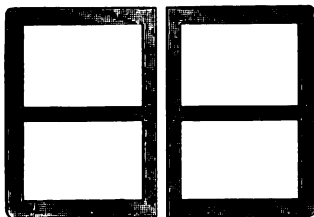

FOLIO CHASES.

No.	Size over all.	Size each, inside.	Price, pair.
1.	.17 x 20 $\frac{3}{4}$.14 $\frac{1}{2}$ x 8 $\frac{3}{4}$	\$ 9.00
2.	.20 x 24 $\frac{3}{4}$.17 $\frac{3}{4}$ x 10 7-16	9.00
3.	.24 x 28 $\frac{3}{4}$.21 $\frac{3}{4}$ x 12 7-16	10.05
4.	.26 x 31 $\frac{3}{4}$.23 $\frac{3}{4}$ x 13 15-16	11.00
5.	.29 x 41 $\frac{3}{4}$.26 $\frac{3}{4}$ x 18 13-16	13.50
6.	.32 x 43 $\frac{3}{4}$.29 $\frac{1}{2}$ x 19 13-16	14.45
7.	.33 x 46 $\frac{3}{4}$.30 $\frac{1}{2}$ x 21 5-16	15.20
8.	.34 $\frac{1}{2}$ x 49 $\frac{3}{4}$.31 $\frac{1}{2}$ x 22 11-16	16.15
9.	.38 x 53 $\frac{3}{4}$.35 $\frac{1}{4}$ x 24 11-16	17.50

With Cross Bars, \$3.00 extra.

WROUGHT IRON CHASES.

Warranted Square and True, and made of the
Best Material.

Book Chase with Shifting-Bars

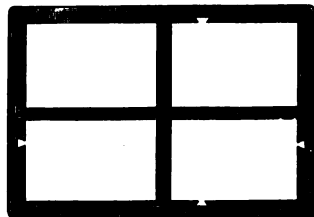

PRICE LIST.

BOOK CHASE WITH SHIFTING-BARS.

No.	Size each, over all.	Size each, inside.	Price, each.
1.	.17 x 20 $\frac{3}{4}$.14 $\frac{1}{8}$ x 18 $\frac{5}{8}$	\$10.50
2.	.20 x 24 $\frac{3}{4}$.17 $\frac{3}{4}$ x 22 $\frac{1}{2}$	10.95
3.	.24 x 28 $\frac{3}{4}$.21 $\frac{3}{4}$ x 26 $\frac{1}{2}$	11.85
4.	.26 x 30 $\frac{3}{4}$.23 $\frac{3}{4}$ x 28 $\frac{1}{2}$	12.25
5.	.27 x 39 $\frac{3}{4}$.24 $\frac{1}{2}$ x 37 $\frac{1}{4}$	13.35
6.	.29 x 42 $\frac{3}{4}$.26 $\frac{1}{2}$ x 40 $\frac{1}{4}$	13.90
7.	.33 $\frac{1}{2}$ x 48 $\frac{3}{4}$.30 $\frac{3}{4}$ x 46	15.15
8.	.37 x 53 $\frac{3}{4}$.34 $\frac{1}{4}$ x 51	16.00
9.	.38 $\frac{1}{2}$ x 54 $\frac{3}{4}$.35 $\frac{3}{4}$ x 52	16.35

Electrotype Chases, 6x8, \$1.00

SKELETON CHASES.

No.	Size each, over all.	Size each, inside.	Price, each.
1.	.17 x 20 $\frac{3}{4}$.14 $\frac{1}{8}$ x 18 $\frac{5}{8}$	\$ 4.50
2.	.20 x 24 $\frac{3}{4}$.17 $\frac{3}{4}$ x 22 $\frac{1}{2}$	4.95
3.	.24 x 28 $\frac{3}{4}$.21 $\frac{3}{4}$ x 26 $\frac{1}{2}$	5.85
4.	.26 x 30 $\frac{3}{4}$.23 $\frac{3}{4}$ x 28 $\frac{1}{2}$	6.25
5.	.27 x 39 $\frac{3}{4}$.24 $\frac{1}{2}$ x 37 $\frac{1}{4}$	7.35
6.	.29 x 42 $\frac{3}{4}$.26 $\frac{1}{2}$ x 40 $\frac{1}{4}$	7.90
7.	.33 $\frac{1}{2}$ x 48 $\frac{3}{4}$.30 $\frac{3}{4}$ x 46	9.15
8.	.37 x 53 $\frac{3}{4}$.34 $\frac{1}{4}$ x 51	10.00
9.	.38 $\frac{1}{2}$ x 54 $\frac{3}{4}$.35 $\frac{3}{4}$ x 52	10.35

9 $\frac{1}{2}$ x11 $\frac{1}{2}$. \$1.75 9 $\frac{1}{2}$ x14, \$2.00

Skeleton Chase.



News Chase.

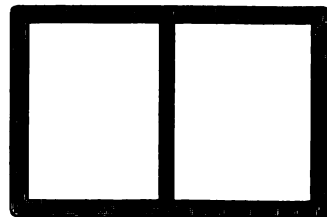

NEWS CHASES.

No.	Size each, over all.	Size each, inside.	Price, each.
1.	.17 x 20 $\frac{3}{4}$.14 $\frac{1}{8}$ x 18 $\frac{5}{8}$	\$ 6.50
2.	.20 x 24 $\frac{3}{4}$.17 $\frac{3}{4}$ x 22 $\frac{1}{2}$	6.95
3.	.24 x 28 $\frac{3}{4}$.21 $\frac{3}{4}$ x 26 $\frac{1}{2}$	7.85
4.	.26 x 30 $\frac{3}{4}$.23 $\frac{3}{4}$ x 28 $\frac{1}{2}$	8.25
5.	.27 x 39 $\frac{3}{4}$.24 $\frac{1}{2}$ x 37 $\frac{1}{4}$	9.35
6.	.29 x 42 $\frac{3}{4}$.26 $\frac{1}{2}$ x 40 $\frac{1}{4}$	9.90
7.	.33 $\frac{1}{2}$ x 48 $\frac{3}{4}$.30 $\frac{3}{4}$ x 46	11.15
8.	.37 x 53 $\frac{3}{4}$.34 $\frac{1}{4}$ x 51	12.00
9.	.38 $\frac{1}{2}$ x 54 $\frac{3}{4}$.35 $\frac{3}{4}$ x 52	12.35

UTILITY PAPER CUTTER

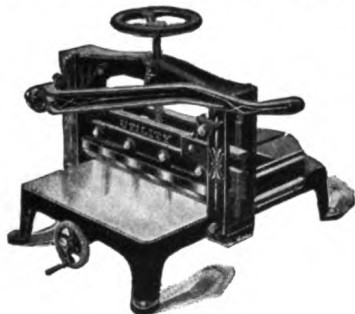

18-INCH CUT

One of the handiest and most useful Paper Cutters on the market. It will save its cost in a very short time as all small work may be cut, such as letter heads, note heads, circulars, cards, and all small work, thus saving the constant wear upon your large cutter.

PRICE, 16-inch . . . \$50.00
 " 18-inch . . . 60.00

GENERAL ELECTRIC MOTORS

They are
 Inexpensive,
 Durable,
 Ever Ready,
 Costs little to
 Operate, and
 Time Savers
 Write for Prices



This machine is made with the style J and K shown on page 235, in 5, 6 and 7 wheels. Any special design of figures can be duplicated at a slight advance over the following prices:

5 Wheel Machine, . . . \$14.00
 6 " " . . . 17.00
 7 " " . . . 21.00

IMPROVED WETTER

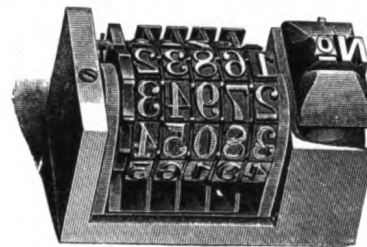

ACTUAL SIZE

A NEW TYPE-HIGH NUMBERING MACHINE

Steel Figures. Entirely Automatic. No Better Workmanship.

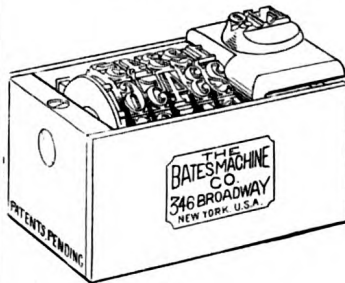

^J
 1234567890

^K
 1234567890

^L
 1234567890

^M
 1234567890

No 12345

Model No. 26, 5 wheels, \$14.00

Model No. 28, 6 wheels, \$18.00

PREMIUM CARD CUTTER

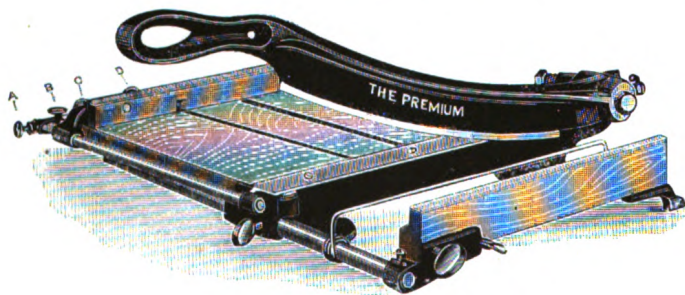

PRICE, \$10.00

THIS is the popular, general, all round machine, with a 12 inch blade, meeting the requirements of a medium sized cutter. A distinctive advantage is secured by a peculiar arrangement of the joint, by means of which a sheet of any length may be cut. By the simple adoption of a spring overhead connected by a cord attached to the handle, the cutter is adapted to rapid work where a great number of small pieces of uniform size are to be cut.

PRICES

Manufacturer's Cutter, 24-inch blade,	\$25.00
The Springfield, 24-inch blade,	18.00
Premium Cutter, 12-inch blade,	10.00
The Popular, 15-inch blade	7.00
Studio Cutter, 10-inch blade,	3.00
Dandy Photo Trimmer, table 8-inch square, . .	2.00
Diamond Photo Trimmer, 6-inch blade,	1.25

IF you are included among the great number of Amateur Photographers you will be interested in the Dandy Cutter or Trimmer, as many prefer to call it. The table is 8 inches square and has a graduated back gauge. The movable blade is curved, giving a drawing cut so essential to smooth work.

The efficiency of the machine is increased by the combination of the curved movable blade and the peculiar construction of its pivotal spring joint, which allows the blade a slight lateral motion and thus secures perfect contact of the two blades at every point.

This gives smooth edges to the card or paper which is cut. A straight upper blade as used in some cutters tends to push or crowd the work out of place.

The superiority of these improvements over the ordinary straight blade with bolt joint may be demonstrated in theory, but a better and quicker evidence is to test the machine yourself.

DANDY PHOTO TRIMMER

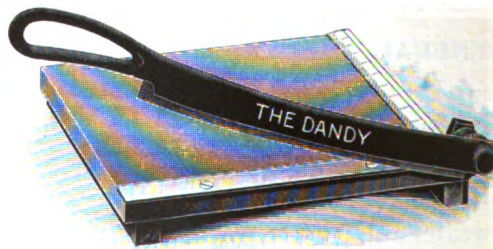

PRICE, \$2.00

ELM CITY BRONZING PAD.



Does away with the waste of bronze so usual in bronzing, not an atom escapes except what is required for the work. Bronze is placed in the top and is delivered through valves in the center of fur at bottom, passing through a sieve before reaching the paper. The quantity of bronze required can be regulated by the screw at the end of the pad. After filling, the sliding door is closed so that no bronze can escape except through the bottom.

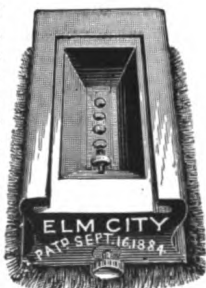

It is of convenient size and very light. By its use a large per cent. of the bronze generally wasted is saved, as the ELM CITY feeds only as fast as wanted, and just where you want it on the work, and not all over the table. You can keep a record of the number of pounds put in for certain work, thus knowing what each job costs for bronze.

PRICE, large size, 2½ x 6 inches, . . . \$2.50
 small " 2¼ inches square, . . . 1.50

UNIVERSAL DUSTER AND BELLOWS



No. 1, Lgh. of Cylinder 16-in. Inside Diam. 2½, Entire Lgh. 20-in. Price, \$1.50
 No. 2, " " 18-in. " " 2½, " " 22½ " 2.00

ELM CITY PRESS PUNCH.

Patent applied for

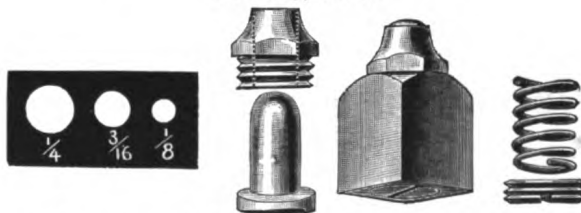

One or more may be locked in a type form and will cut a clean, round hole, 1-8, 3-16 or 1-4 inch in paper or card stock at the same time the job is printed. This punch will not clog as each piece cut is automatically ejected by the plunger as soon as the impression is released. The ejector protects the rollers from any danger of injury from the cutter. The punches are made on 30 and 36-Pt. bodies. All parts being interchangeable, new cutters can be readily fitted in case of accident. Cutters are made 2 points lower than type to allow for pasting a small square of cutting fibre on the tympan, furnished with punches.

PRICES	{	Per Set for cutting 1-8, 3-16 and 1-4 inch holes,	\$1.50
		One Punch, any size,	.75
		Extra Cutters, made of finest tool steel,	.15
		Cutting Fibres, per doz.,	.10

BREHMER WIRE STITCHERS

This Brehmer style Wire Stitcher is built especially for printers and bookbinders to cover the capacity required for the general class of booklet, pamphlet, novelties, and calendar pad stitching. Simplicity of construction, perfect stitching, ease of operation, small cost for renewal of wearing parts, and exposed mechanism are features of superiority that make the Brehmer the best Wire Stitcher.

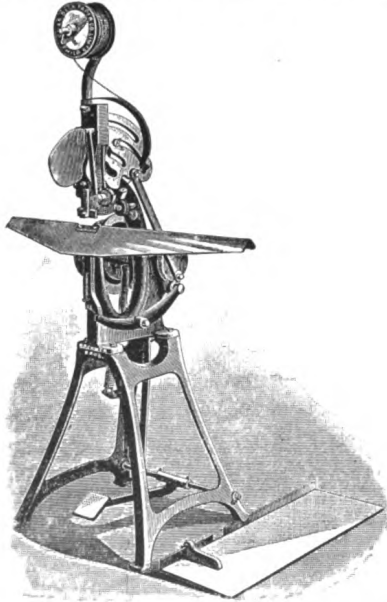

Nos 33



No. 31

PRICES:

No. 33.	Belt Power, Iron Stand,	to 1-5 inch thick,	\$150.00
No. 31.	Treadle Power, Iron Stand,	to 1-5 inch thick,	100.00
No. 30.	“ “	Bench Machine, to 1-5 inch thick,	80.00

Over 25000 Brehmer Stitchers in use.

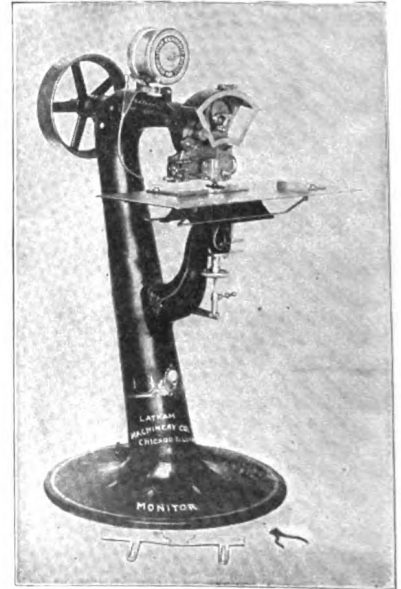
**No. 1. 20th Century
Monitor Wire Stitcher**

Combined Roll and Straight Feed, capacity two sheets to 7-8 inch, uses 25, 26, 27, 28 and 30 round wire, 20 x 25 flat wire.

PRICE, \$450.

THE "COLT'S ARMORY" PRESS PRINTING AND EMBOSSING

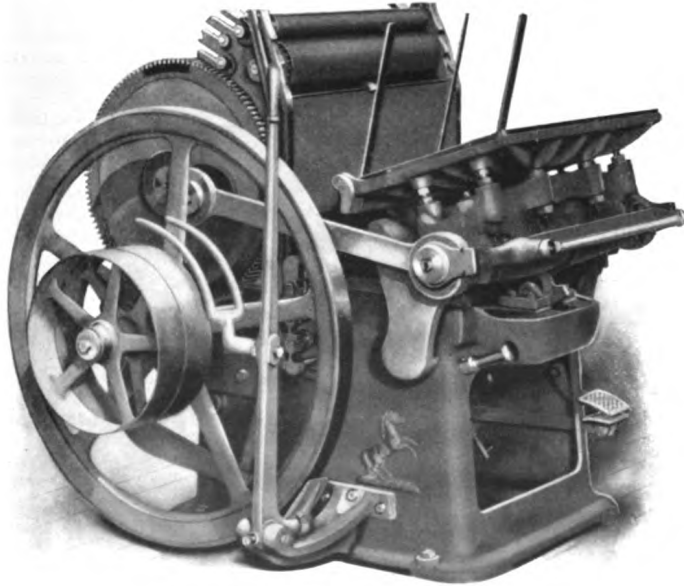

Carried in stock and for sale by

H. C. HANSEN, TYPE FOUNDER,

WRITE FOR PRICES

EXCLUSIVE FEATURES OF "COLT'S ARMORY" PLATEN PRINTING PRESSES.

The relief of the platen controlling action during the impression.

The chase latch, arranged to be operated by a pedal and to hold the form where it belongs.

The automatic oil reservoir for the crank pins and their bushings.

The drop-forged steel connecting rods.

The operating mechanism of ink fountain, causing a positive feed of ink at any rate of deposition desired.

The hook connection, locked to hardened steel roller.

The heavy Tympan clamps.

The wide feeding angle of platen and its slow moving dwell.

The combined brake and belt shifter.

The smoothest and most durable action.

The detachable journal boxes, for distributor stocks avoiding wear of carriage ways.

The construction of adjuster bar and sleeves, saving expensive break-downs, and permitting the use of hard tympan without adjusting the impression bolts.

The fly-wheel can be stopped within half of a revolution.

The long, direct slide to the impression, with the heavy elongated guiding ears or bridge, securely locked upon the frame, ensuring registration

THE JONES GORDON PRESS

THE BEST JOB PRESS IN THE WORLD.

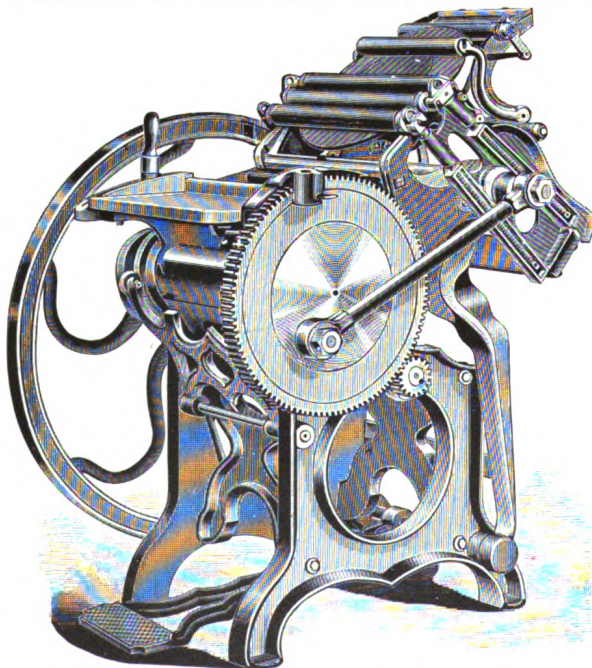

HAS TIME AND LABOR SAVING FEATURES FOUND ON NO
OTHER PRESS OF THIS PATTERN.

SUPERIOR AT EVERY POINT.

Roller Pulls: It has loops on the roller carriage heads. Keeps your hands clean while taking out or putting in rollers.

Heaviest Press Built: The Jones Press is the heaviest press of this pattern built. It has no competitor in this line.

Gear Wheel Guard: This also holds the fly to the feed-board and throws it to the right of the large gear wheel, giving the feeder more elbow room than on any other press.

Form Starter: When the chase is released, the form is started from the bed of the press, giving the pressman a chance to get a good hold on it before starting to lift out

Self-Locking Chase-Hook: By this device the chase is automatically locked in place and cannot get out until released. The pressman does not have to touch the chase-hook in putting in the form.

Light Running: This feature has not been forgotten. The great weight of the Jones Press has been so evenly distributed, the heavy parts so nicely balanced, that it requires very little more exertion to run, even the larger sizes, than it does an ordinary sewing machine.

Perfectly True: Our beds and platens are hand-scraped to a perfectly true surface after leaving the planers, thus making it possible to print a full form of solid type as easily and with as little make-ready as it does a single line. You do not have to stop to build up low places in the bed or platen. We do that for you in putting them in our special process of hand-scraping.

SIZES AND PRICES

8 x 12	· · ·	\$135.00	12 x 18	· · ·	\$240.00
10 x 15	· · ·	200.00	14 x 20	· · ·	310.00
			14½ x 22 Frame Cast Solid		\$340.00

Steam Fixtures, \$10.00. Short Fountain, \$10.00. Old Style Long Fountain, \$20.00. Duplex Distributing Fountain, \$25.00. Roller Throw-off, 25.00. These prices include set of cast rollers cast brayer (or mould in place of rollers), extra set of stocks, and three chases.

The Lightning Jobber

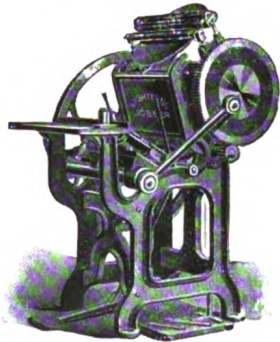

SIZES AND PRICES

7 x 10	\$ 95.00	9 x 13	\$120.00
8 x 12	105.00	10 x 15	145.00
Steam Fixtures, \$10.00.		Long Fountain, \$20.00.	
		Short Fountain, \$10.00	

This price includes two chases, cast rollers or mould and an extra set of stocks.

Chandler & Price Presses & Cutters

7x11 C.&P. Gordon	\$125.00	8x12 C.&P. Gordon	\$135.00
10x15 " "	200.00	12x18 " "	240.00
14x20 " "	310.00	14½x22 " "	340.00
Steam Fixtures, \$10.00		C.&P. Long Fountain, \$20.00	
		Buckeye Fountain, \$10.00	

23-inch Paper Cutter,	- - -	\$ 95.00
26-inch " "	- - -	115.00
30-inch " "	- - -	150.00

The IDEAL Paper Cutters

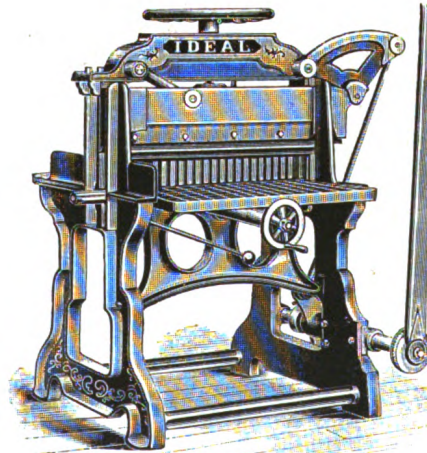

SIZES AND PRICES

20-in.	\$80.00	25-in.	\$110.00
30-in.	150.00	32-in.	165.00

Front Table 16 inches wide in 30 and 32 inch Cutters instead of the usual 12 inches. In 25-inch Cutter it is 12 inches.

A constant stock of these Cutters and Presses on hand.

Muller Patent Half-tone Softening Hammers and Punches

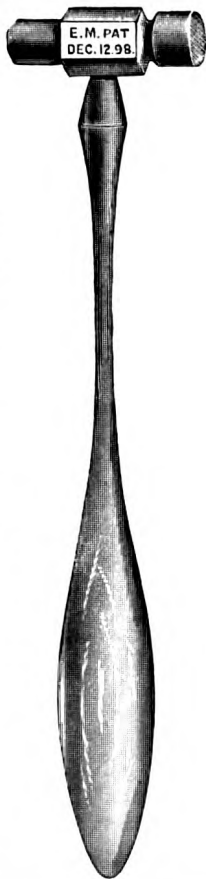

For softening harsh vignettted edges of illustrations, whether original half-tones, electros, stereos, or woodcuts.

Lines to match any screen are cut on a convex surface, in hand-forged steel, with sharp cutting edges

Hammers also made for use on stipple and grain work.

The harsh edges of cut are tapped with hammer, and the results are magical.

No special skill is required.

Punches are for use where there is no room for the hammer.

Any screen desired is furnished, and a different screen at each end of No. 1 Hammer. In ordering state screen desired.

No. 1 Hammer, screen at both ends,
\$5.00 net.

No. 2 Hammer, screen at small end
and stipple at large end, \$6.50 net.

No. 3 Hammer, screen at small end,
burnisher at large end, \$3.50 net.

Oblong Punch, $\frac{1}{2}$ x $\frac{3}{8}$, any screen,
\$1.50 net.

Square Punch, $\frac{1}{2}$ x $\frac{1}{2}$ any screen,
\$1.50 net.

GALLEY PROOF PRESS.

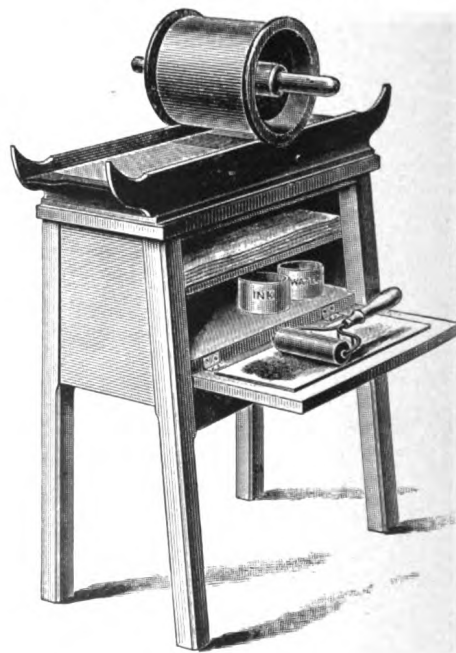

SIZES AND PRICES.

No. 1, 5 x 27 in.	\$15.00; with stand	\$22.00
" 2, 8 $\frac{1}{4}$ x 27 "	20.00; " "	27.00
" 3, 15 x 27 "	30.00; " "	38.00
Boxing75

A brayer included with every press.

SPECIAL FEATURES OF THE PROUTY PERFECTED PRESSES.

Strength. Steel shafts extending through the entire length of press; double gears and pinions; solid platen, backed by six impression screws; solid frame and bed. It is heavier than any other press of its size, and the weight put where it does most good, not into counter weights.

Speed. Limited only to the capacity of the feeder. Printers are running the largest size press at a speed of 2,000 per hour all the time, and the smaller sizes at 3,200 per hour; faster than any other press will do and STAND IT.

Distribution. By the aid of the patented fountain and four rollers with patented trucks, we get a distribution giving the same results as the angle rollers on cylinder presses.

The Frame and Bed are combined in one substantial casting, provided on the inside with heavy ribs extending from one bearing to another. This construction insures an absolutely unyielding bed and a rigid foundation for the working parts. It prevents, as no other method can, all possibility of the bearings being thrown out of line, and consequent cramp and wear when the press is placed upon an uneven floor.

Bushed Bearings. All of the frame-bearings subject to wear are provided with heavy bushings (linings), which, in case of wear after years of service, may be readily and cheaply replaced. The frame is thus rendered practically indestructible.

Platen-Adjuster. The movement of a lever located on left side of the press, just below the platen, gives the pressman instant and perfect control of the platen in its parallel relation with the bed or form. The only objection to the vibrating platen is thus overcome, and the use of a wrench in adjusting the platen seldom if ever becomes necessary.

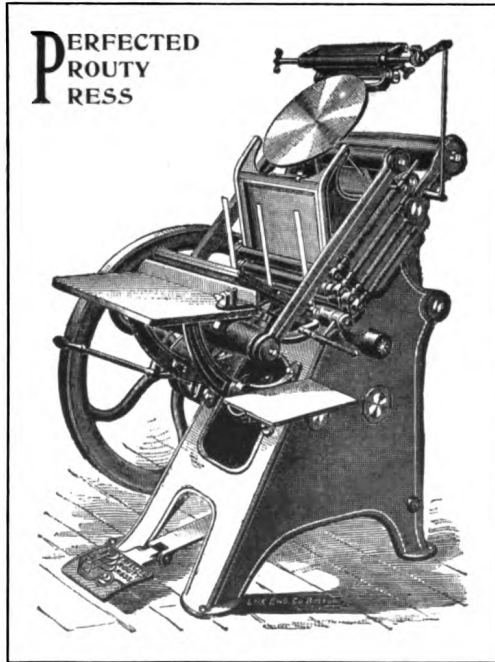

SIZES AND PRICES.

No. 1 Press.

Size of chase inside, 7 x 11 in. . . \$185.00
 Ink Fountain 20.00
 Steam Fixtures 10.00
 Net weight complete, 725 lbs.

No. 2 Press.

Size of chase inside, 9 x 13 in. . . \$250.00
 Ink Fountain 22.00
 Steam Fixtures 12.00
 Net weight complete, 1,300 lbs.

No. 3 Press.

Size of chase inside, 10 x 15 in. . . \$300.00
 Ink Fountain 24.00
 Steam Fixtures 14.00
 Net weight complete, 1,800 lbs.

No. 4 Press.

Size of chase inside, 12 x 18 in. . . \$375.00
 Ink Fountain 26.00
 Steam Fixtures 16.00
 Net weight complete, 2,600 lbs.

Special No. 4, 13 x 21 \$455.00

This size is particularly adapted for wood printing and embossing.

Boxing, when necessary, No. 1, \$2.00, No. 2, \$3.00, No. 3, \$4.00, No. 4, \$5.00, delivered F. O. B. at Boston.

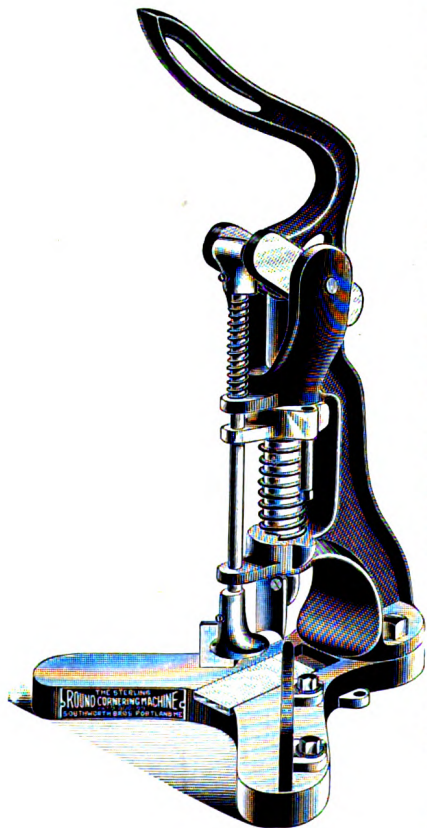

The Sterling Round Cornering Machine. Price, \$15.

Punching Attachment,	\$10.00
Stabbing Attachment,	\$5.00
Extra Knives, 5 sizes, each,	\$1.25
Extra Punches, 5 sizes, each,	\$2.00
Extra Needles, for stabbing, each,	.15
Cutting Blocks, per doz.,	.35

Designed to meet the requirements of Printers and Book-binders.

Write for further particulars.

The "Success" Wire Stitcher No. 2.



No. 1, for Hand Power, \$40.00

No. 2, for Hand and Foot Power, \$65.00

Wire per Spool
50 cents.

STANDARD TYPE MEASURES.

3-Em. 

4-Em. 

5-Em. 

6-Em. 

8-Em. 

10-Em. 

12-Em. 

13-Em. 

21-Em. 

30-Em. 

For setting Composing Sticks perfectly to any number of ems desired, and as Standards for cutting Leads and Brass Rule, and for ascertaining the accuracy of Type or any Point System Material, these Measures will be found invaluable in every Printing Office and Type Foundry.

They are made in lengths as shown herewith, viz.: 3, 4, 5, 6, 8, 10, 12, 13, 21 and 30 ems 12-Point (Pica), and may be used separately or in combination to make any length desired from 3 to 112 ems Pica. They are accurately adjusted to the Point System Standard as adopted by all the Type Founders in the United States.

On the 30 em Pica measure is marked the required number of ems of the different Point System type bodies equal to its length.

Explanation. Place the 30-em Pica Standard in a composing stick, then place the number of ems of any of the bodies marked upon its face in the stick, and if your type is correct it will justify accurately with the Standard.

Price for Complete Set, \$5.00

H. C. HANSEN.		30	12-PT.	36	10-PT.	40	9-PT.	45	8-PT.	60	6-PT.	360	1-PT.	32	11-PT. AND 1	8-PT.
														51	7-PT. AND 1	3-PT.



THE H. C. HANSEN POWER IMPROVED PIN-HOLE PERFORATOR.

THIS cut represents the New Pin-Hole Perforating Machine, which for durability, strength, and general adaptability to the purposes for which it is intended stands second to none, having a number of advantages over all other machines. It will perforate a sheet 26 inches wide and any desired length.



It consists of two die wheels placed in such a position as to register perfectly, with no gearing to get out of order.



It has a nicely finished table with gauge on side which can be quickly and accurately set at any desired distance from the point of perforation.



An excellent feature of this machine, and one that will be appreciated, is that it does the work in less than one-fourth the time consumed by any other machine, and may be run either by hand or steam power.

The following are expressions of but a few of the many using this Perforating Machine who have testified to its good qualities.



ROCKWELL & CHURCHILL.

MR. H. C. HANSEN,

Dear Sir:—It is with pleasure that I write of our experience with the perforating machine purchased of you in July, 1888. It has been in use nearly every day on all kinds of stock, and the perforation is as clean on 16 lb. folio as it is on the heavy ledgers or card stock. Your instructions to run only one sheet at a time has not been our custom, as we run three or four at once of ordinary stock with clean work and without apparent injury to the machine. I have never seen its equal for rapidity and perfection on straight work.

E. L. SLOCOMB,

Foreman Job Room.

MR. H. C. HANSEN,

Dear Sir:—Your Pin-Hole Perforating Machine far exceeds our expectations. We have perforated in the past four months over 300,000 sheets of paper, from a half note to a full sheet folio, and with a half inch head and through centre of sheets. We are satisfied that the machine will do all you claim for it and can recommend it to anyone having straight perforating to do. Yours truly,

HARTFORD FIRE INS. CO.

W. H. BARNARD, Supt. Ptg. Dept.

MR. H. C. HANSEN

We have had one of your Rotary Perforators in constant use for the past seven years and it has given us good satisfaction. Yours truly,

A. E. MARTELL & CO.

PRICE, Complete, \$50.

THE IMPROVED
Horton Mailer.

\$20.00

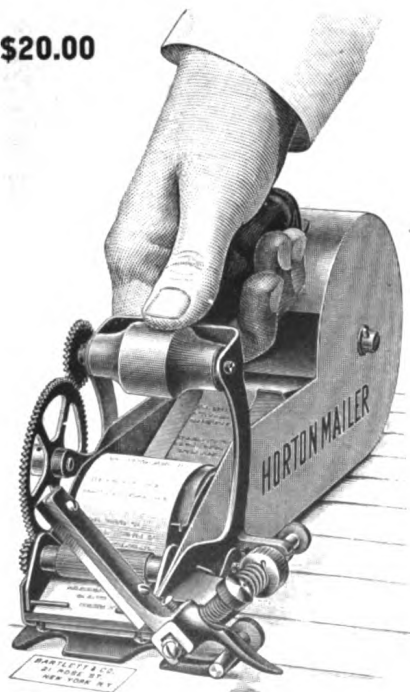

No matter what mailer you now use, it will pay to replace it with the Horton.

The Horton Mailer is guaranteed to do better, easier and faster work than any other machine.

It is easy to learn to operate, requiring but a few minutes' practice to attain a good rate of speed.

It is 12 inches long, 3 inches wide, 5 inches high, and weighs two and three-quarter pounds. Delivered in a strong wooden box.

When ordering Mailer do not forget to give width of mailing slip.

ROUSE'S AMERICAN LEAD AND RULE CUTTER

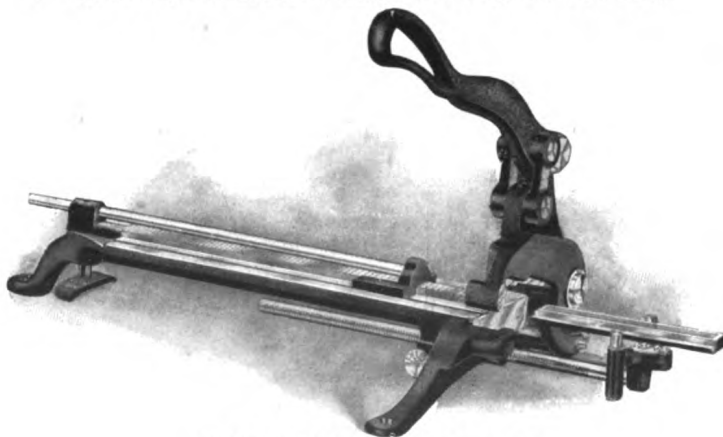

AMERICAN LEAD AND RULE CUTTER NO. 2

CAPACITY AND PRICES.

No. 2, Gauges to 105 Picas, by Nonpareils,	\$10.00
No. 3, Gauges to 105 Picas, by Nonpareils, also to 45 Picas, by Points,	\$12.00

LARGE STOCK OF THE CELEBRATED SIGMUND ULLMAN CO.'S PRINTING INKS.

PUT UP IN TUBES, 1-4, 1-2, 1, 5, AND 25 LB. CANS.

BLACK.		BLUE.		GREEN.		BRONZES	
Per lb.		Per lb.		Per lb.		Per lb.	
High grade news ink, 5 lbs. or over.....	\$.15	Azure Blue.....	\$2.50	Olive Green.....	\$2.00	Pale Gold per lb.....	1.25
Book Black.....	.30	Bronze Blue No. 1.....	2.50	Dragon Green.....	3.00	Silver.....	1.75
Job " and Comb.....	.40	Imperial Blue.....	3.00	Regal Green.....	3.00	VARNISH.	
" " ".....	.75	Berlin Blue.....	2.00	Silk Green.....	2.00	Varnish No. 0.....	\$.50
" " ".....	.50	Ultramarine Blue No. 2.....	2.50	Bronze Green.....	2.00	Liquid Dryer.....	.75
Zulu Black.....	.50	Ultramarine Blue No. 3.....	3.00	Light Green.....	1.50	REDUCING COMPOUND.	
Zulu Black in 10 lb. lots.....	.35	Milori Blue.....	3.00	Dark Green.....	1.50	1, 2, 5 and 10 lb. cans at 50c. per lb.	
Nubian Black No. 5.....	1.00	Oriental Blue.....	2.50	Poster Green.....	.50	Hawkins'.....	50c.
Nubian Black No. 4.....	1.50	Bronze Blue No. 4.....	1.00	French Green Lake, deep.....	2.00	SPHINX PASTE.	
Half Tone Nubian Black.....	1.00	Bronze Blue No. 2.....	2.00	YELLOW.		1-2 Pint.....	\$.10
Combination Black.....	2.00	Light Blue.....	1.50	Chrome Yellow, Deep.....	\$2.00	Pint.....	.15
" ".....	3.00	Deep Blue.....	1.00	Chrome Yellow, Light.....	1.50	Quart.....	.25
" ".....	5.00	Poster Ultramarine Blue.....	.50	Lemon Yellow.....	2.00	PAD CEMENT.	
" " Half-tone.....	2.00	Imperial Purple.....	3.00	Persian Orange.....	2.00	1-2 Pint.....	\$.30
" ".....	3.00	Bluish Violet.....	5.00	Poster Yellow, Light.....	.50	Pint.....	.50
" ".....	5.00	RED.		WHITE.		Quart.....	.90
Document Black.....	1.50	Poster Red.....	\$.50	Fine White.....	\$1.00	Gallon.....	3.00
Gloss Black.....	2.00	Job Red, light.....	1.50	Printing White.....	2.00	MAILING MACHINE GUM.	
Blue Black.....	1.50 & 2.50	" " deep.....	1.50	Magnesia White.....	1.00	5 Gallon kegs.....	\$2.25
Bronze Blue Black.....	2.50	Bronze Red.....	5.00	DOUBLE-TONE		10 Gallon kegs.....	4.00
Green Black.....	2.00	Brilliant Lake.....	5.00	Antique Bronze.....	\$4.00	25 Gallon bbls.....	8.00
Plate Black.....	1.50	Deep Cherry Red.....	4.00	Light Sepia, A.....	2.50	GROVER'S	
Engravers' Proof.....	8.00	Superior Rose Lake.....	3.00	Agate.....	2.50	PRINTERS' DETERGENT.	
BROWN.		Permanent R. R. Red I.....	3.00	Purple Black, A.....	2.50	1 lb. cans.....	\$.20
Bismarck Brown.....	\$3.00	Permanent R. R. Red II.....	2.50	Greenish Black, A.....	2.50	5 lb. pails.....	.75
Chocolate Brown.....	3.00	Permanent R. R. Red III.....	1.50	Commercial Blue, A 4.....	2.50	10 lb. pails.....	1.25
Photo. Brown, Light.....	3.00	Permanent R. R. Red IIII.....	1.00	Blue Grass, A.....	2.50	ELECTRIC DISSIPATOR.	
Mahogany Brown.....	2.00	Brilliant Red O.....	2.50	Black 4 A.....	2.50	Pint bottle.....	1.00
Sienna Brown.....	2.00	Brilliant Red I.....	1.50	Bronze Green, 3 A.....	3.00	Quart bottle.....	2.00
Bronze Brown.....	4.00	Brilliant Red II.....	1.25	Maroon A.....	2.50	Gallon bottle.....	7.00
Poster Brown.....	.50	Brilliant Red III.....	1.00	Olive Black.....	2.50	ARABOL PADDING COMPOSITION, SOLIDIFIED	
COPYING INK.		Brilliant Red IV.....	1.00	BRONZES.		3lb. pail.....	\$1.00
Red, Scarlet, Green, Purple.....	\$3.00	Brilliant Red V.....	1.00	Rich Gold per oz.....	\$.10	6 " ".....	1.50
IMITATION TYPEWRITER		Brilliant Red VI.....	1.00	Rich Gold per lb.....	1.00	12 " ".....	3.00
Purple, Red, Blue, Green, Black.....	\$3.00	Fine Vermillion.....	1.50	Rich Gold per lb.....	1.25	And up at 25c. per pound	
ALUMINUM INK.		Gloss Red.....	2.00	Pale Gold per lb.....	1.00	Potash.....	.15 cents
Aluminum Ink.....	\$5.00	GOLD SIZE.		GOLD INK.			
		Gold Size.....	\$1.50	Gold Ink, deep and light.....		\$5.00	

TINTS, \$1.00 and \$1.50 per pound

THIS SPECIMEN BOOK WAS PRINTED WITH SIGMUND ULLMAN CO.'S PRINTING INKS.

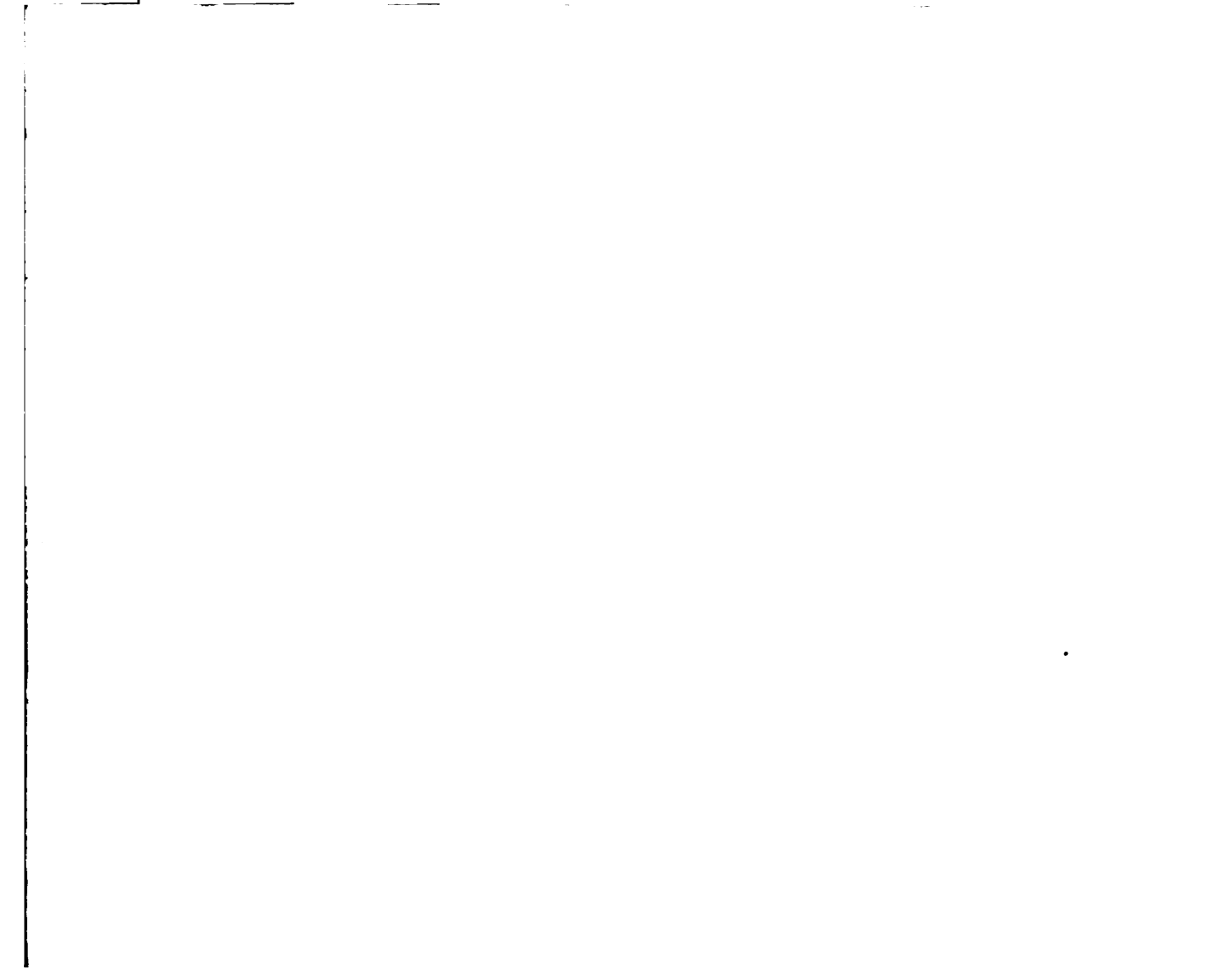

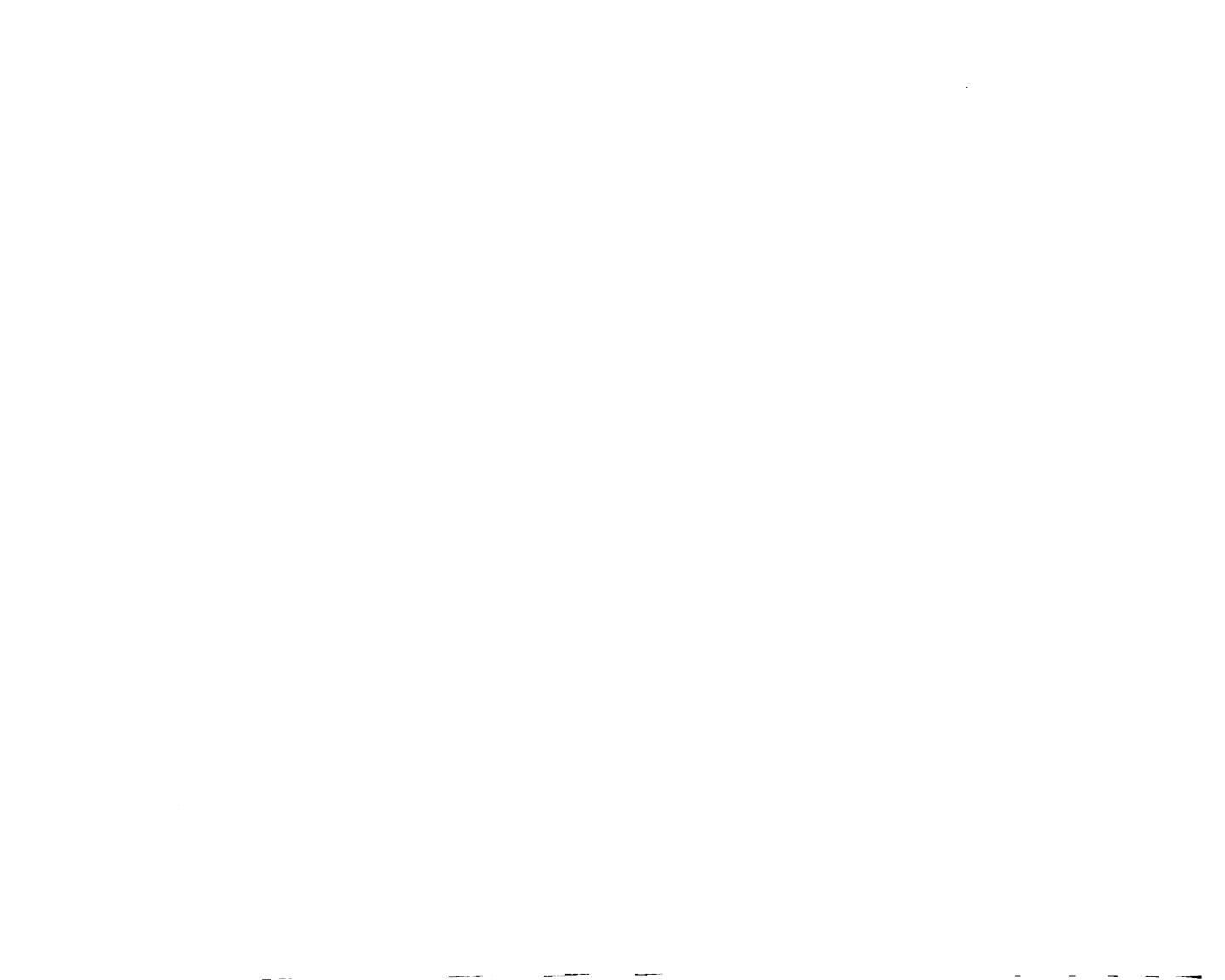



APR 24 1956



