



This is a digital copy of a book that was preserved for generations on library shelves before it was carefully scanned by Google as part of a project to make the world's books discoverable online.

It has survived long enough for the copyright to expire and the book to enter the public domain. A public domain book is one that was never subject to copyright or whose legal copyright term has expired. Whether a book is in the public domain may vary country to country. Public domain books are our gateways to the past, representing a wealth of history, culture and knowledge that's often difficult to discover.

Marks, notations and other marginalia present in the original volume will appear in this file - a reminder of this book's long journey from the publisher to a library and finally to you.

Usage guidelines

Google is proud to partner with libraries to digitize public domain materials and make them widely accessible. Public domain books belong to the public and we are merely their custodians. Nevertheless, this work is expensive, so in order to keep providing this resource, we have taken steps to prevent abuse by commercial parties, including placing technical restrictions on automated querying.

We also ask that you:

- + *Make non-commercial use of the files* We designed Google Book Search for use by individuals, and we request that you use these files for personal, non-commercial purposes.
- + *Refrain from automated querying* Do not send automated queries of any sort to Google's system: If you are conducting research on machine translation, optical character recognition or other areas where access to a large amount of text is helpful, please contact us. We encourage the use of public domain materials for these purposes and may be able to help.
- + *Maintain attribution* The Google "watermark" you see on each file is essential for informing people about this project and helping them find additional materials through Google Book Search. Please do not remove it.
- + *Keep it legal* Whatever your use, remember that you are responsible for ensuring that what you are doing is legal. Do not assume that just because we believe a book is in the public domain for users in the United States, that the work is also in the public domain for users in other countries. Whether a book is still in copyright varies from country to country, and we can't offer guidance on whether any specific use of any specific book is allowed. Please do not assume that a book's appearance in Google Book Search means it can be used in any manner anywhere in the world. Copyright infringement liability can be quite severe.

About Google Book Search

Google's mission is to organize the world's information and to make it universally accessible and useful. Google Book Search helps readers discover the world's books while helping authors and publishers reach new audiences. You can search through the full text of this book on the web at <http://books.google.com/>

HAWKS & SHATTUCK'S
Specimen Book
AND PRICE LIST.

P. 3087.

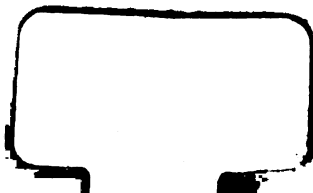

S

K

MATERIAL

REET.

Digitized by Google

Price List of Roman Type.

	25 lb Founts and over	Founts under 25 lbs	25 lb Founts and over	Founts under 25 lbs
Pearl	\$ 1.20	\$ 1.80	Great Primer	\$.40 \$.60
Agate	.74	1.44	Paragon	.40 .60
Nonpareil	.64	1.16	Dbl. Small Pica	.40 .56
Minion	.56	1.00	Double Pica	.40 .56
Brevier	.52	.90	Double English	.40 .56
Bourgeois	.48	.80	Five-line Nonp'l	.40 .56
Long Primer	.46	.74	Dbl. Gr. Primer	.40 .56
Small Pica	.44	.70	Double Paragon	.40 .54
Pica	.42	.66	Seven-line Nonp	.40 .54
English	.40	.62	Four-line Pica	.40 .54

Sorts sold at same rate as 25-pound founts.

In ordering Body Type, state whether Italic, Leaders or Accents are wanted.

HOW TO ORDER.

ORDER by NAME and NUMBER. NEVER cut the Book. When you order from any other book, be sure to mention what book it is.

When Quads and Spaces are wanted for Display Founts, make an order for them, as they are sold separately.

When giving measure for Leads, Slugs or Rule, by ems, Pica ems are always understood, unless otherwise specified.

Write orders on separate sheet from letters. Put each item on a line by itself.

Always state how you wish goods shipped, whether by boat, rail or express.

When shipping old type to us, mark your own name on every package.

When ordering Chases, send diagram with correct inside and outside measures marked.

When writing for information, tell us what you want us to do, rather than ask us what we can do. Knowing your wants, we aim to supply them. To ask us what we can do is to set us to guessing what you want.

TERMS.

Parties who are established in business, doing well, and have a good reputation for promptness in paying their bills, can have as good accommodation here as at any other house. Such persons are entitled to the usual 60 days on our books. When extension is desired, it will be necessary to notify us before the expiration of the time, and specify the time asked for. On such extensions interest will be charged at the rate of 1 per cent. per month; and if more than two months is allowed, the account must be closed by note.

No accounts will be opened with those we are not acquainted with. Parties desiring credit must furnish unquestionably good reference, near at hand.

For prompt payment *within* 30 days from date of purchase, we allow a discount of 10 per cent. from list. On machinery 5 per cent. For spot cash 2 per cent. additional discount is given.

Wood type, Zylotype News Plates, and a few minor articles are net.

PRICES.

Particular attention is directed to the fact that the prices given are, without any exception, *Eastern List Prices*, and are therefore, in some instances, from 10 to 15 per cent. lower than the quotations of other houses, who advance prices "to cover freight." Compare them and see for yourselves.

Prices of job founts are changed in many cases owing to the adoption of Point System and New Schemes. Don't imagine that the number of A's in a fount determines the price of a fount; prices are not arbitrary, but are arrived at by weight.

Address all communications to

HAWKS & SHATTUCK, 409 WASHINGTON STREET, SAN FRANCISCO, CAL.

HAWKS & SHATTUCK'S

△ **NEW** △

SPECIMEN BOOK

AND △ PRICE △ LIST △ OF

STANFORD LIBRARY

TYPES, RULES, BORDERS AND OTHER PRINTING MATERIAL

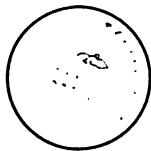

SAN FRANCISCO:
OFFICE AND WAREROOM, 409 WASHINGTON STREET.

1889

Digitized by Google



a. 14645.

Y9A98L1 0907MAY8

HAWKS & SHATTUCK'S

Illustrated Price List.

ACCOUNT BOOKS.

BRADBURY'S		
Advertising.....		3 00
Job.....		3 00
Subscription, 1,000 names.....		3 00
CHALLEN'S		
Advertising, 52 pages.....		1 00
" 100 ".....		2 00
" 200 ".....		3 00
Subscription, 750 names.....		1 00
" 1500 ".....		2 00
" 3000 ".....		3 00

ANNEX BOXES.

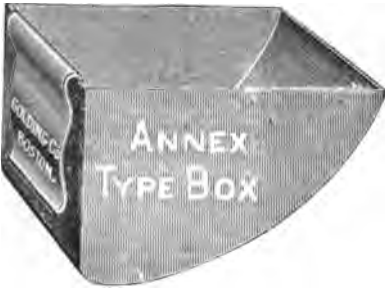

Each..... 25

BELLOWS.

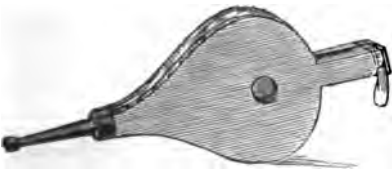

Medium Size, 6 inches..... 90
Large " 8 "..... 1 15

BODKINS.



Common..... 15

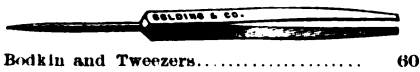

Bodkin and Tweezers..... 60

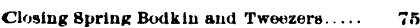

Closing Spring Bodkin and Tweezers..... 75



Tweezers, common..... 25
" medium..... 40
" fine..... 60
" extra fine..... 75

BENZINE CANS.



Quart..... 75

BRUSHES.

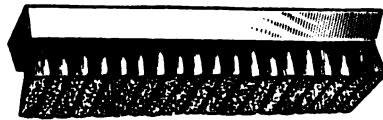

Ley, best bristle, full size..... 1 00
" " " medium size..... 75
" " " small size..... 50
Tampico..... 65

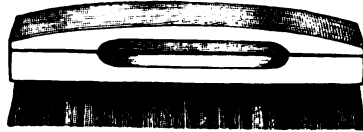

Benzine..... 50



Cement; 1 inch..... 25



Proof..... 1 00

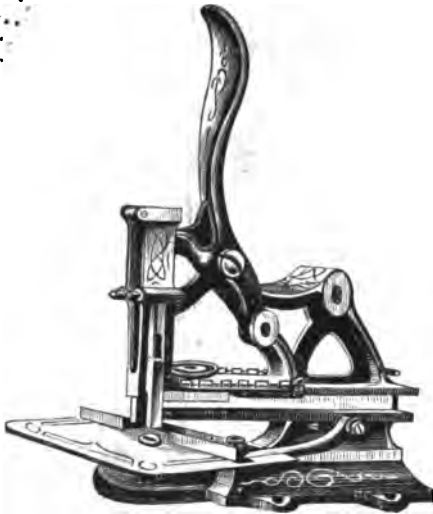

LIGHTNING STAPLE BINDER.

This machine holds 200 staples at a charge, and delivers, drives and clinches automatically. There is only one adjustment, and that is by a handsome screw under front end of machine. The work is done rapidly and thoroughly. Every wearing part of the machine is made of hardened steel. "There is more machine for the money" in this machine than in anything of the kind ever made.

The weight is 15 lbs.; length, 15 inches; width, 10 inches; height, 16 inches, and there is space enough under the arm to allow of driving the staples seven inches from the margin. A Treadle Attachment can be applied in five minutes, and is so arranged that the machine becomes automatic in every respect.

The staples are strung on wooden rods, and easily inserted in the machine.

PRICES.

With hand lever.....\$18 00
Foot-power attachment, extra..... 6 00

STAPLES.

No. 7, 3-16 inch, for 2 to 16 shs., per 5000..\$ 1 25
" 8, 1-4 " " 16 " 32 " " .. 1 25
" 9, 5-16 " " 32 " 60 " " .. 1 25

HERCULES STAPLE BINDER.

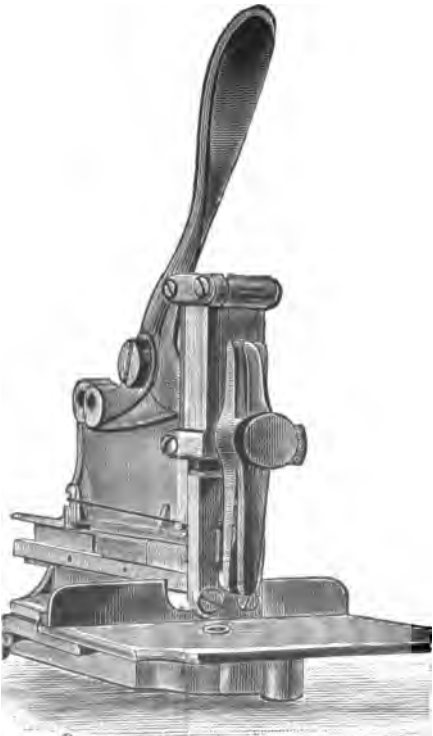

This machine is calculated to fill a space in the list between the Breech Loader and the Lightning and proves an excellent machine to the printer, by which he can effectually do all his light pamphlet work.

Price, complete, with foot power.....\$10 00
Staples, per 1,000..... 25

Staples are strung on wood and put up in boxes of 5,000 each size. Size F, 3-16 inch; size G, 1-4 inch; size H, 5-16 inch; size K, 3-8 inch length of leg.

Always mention name of machine you use when ordering staples.

BREECH LOADER WIRE STAPLE BINDING MACHINE

This machine binds papers of all kinds with wire staples; holds 100 staples at a charge; feeds them automatically; inserts them one by one into the job, and clinches them flat on under side of the papers. Its capacity is from 1 to 50 sheets, and it does its work easily.



Price.....\$3 00
Staples, 3-16, 1-4, 5-16 in., box of 500..... 25

SINGLE-STROKE STAPLE PRESS.



Price.....\$1 50
Staples, per 1,000..... 1 00

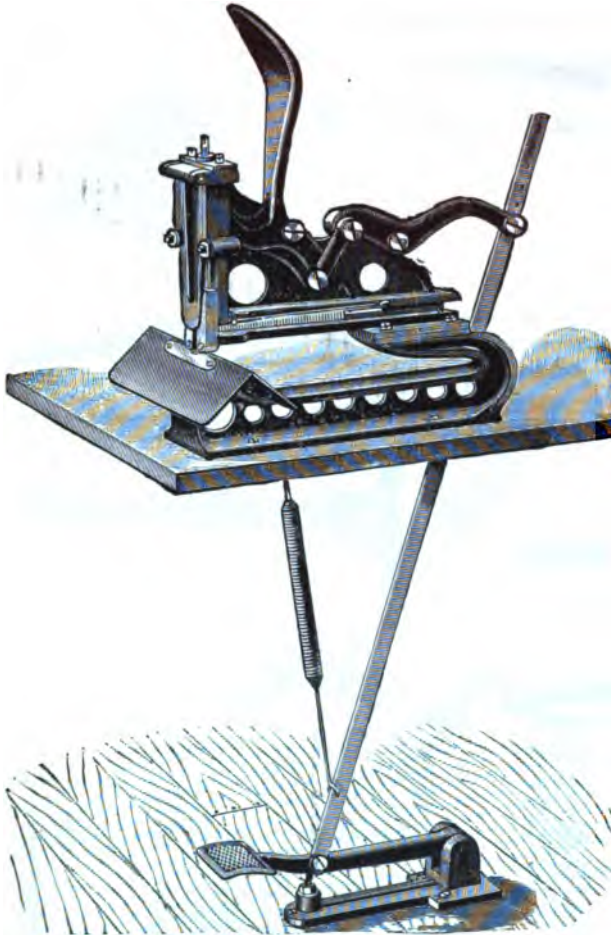

**MIDDLE STITCH
OR "SADDLE BACK"
BINDER.**

An indispensable machine for Book-binders, Printers and Stationers, for binding pamphlets of any thickness under 125 pages through the fold.

Very Useful when Binding Calendars.

Length under arm, 12 inches

PRICE \$30.00.

Staples put up in boxes of 5,000. Price \$1.25 a box.

In ordering Staples please mention name of machine.

IMP'D. TABLET HOLDER AND CLAMP.

Used for straightening up and holding sheets of paper while being glued for tablets.

Will hold any quantity up to 3,000 sheets of paper, and any size from 2½x2½ to 8½x14 inches. With an additional clamp and larger Press Boards, almost any size of work can be easily handled.

Accommodates all the various sizes of commercial stationery, and readily admits of their being glued on one or both sides.

It is strong, easily understood, nothing about it to break or get out of order. It is almost indestructible, and so simple that any one can use it.

PRICES.

Price of Tablet Holder and Clamp, including four Beveled Press Boards for blocking.....\$ 3 25
Price of Extra Clamps..... 1 35

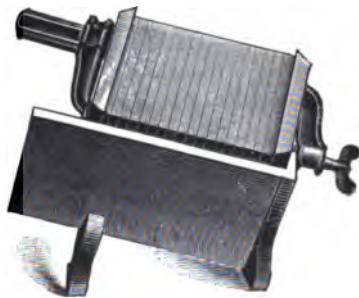

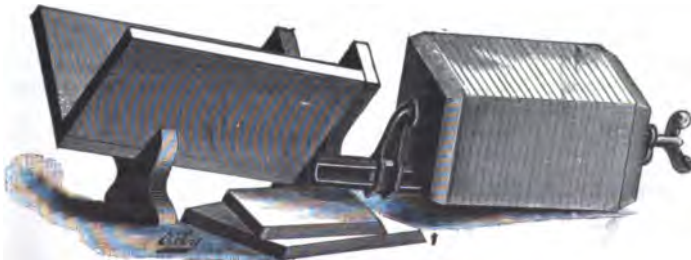

(Tablets being evened and clamped.)

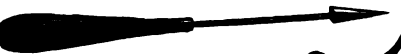

(Tablets with surface ready for gluing.)

OUTFIT FOR BRASS RULE WORK.

Soldering Copper.....	\$0.45		Flat Pliers.....	\$0.45
Blow Pipe, with ball.....	40		File Stone.....	35
Soldering Acid.....	20		Square Graver.....	25
Wire Solder, bunch.....	10		Files, smooth cut.....	30
Round Flyers.....	35		Try Square, 3 in.....	75
Price, complete, boxed.....			\$3.60	

BRACKETS.

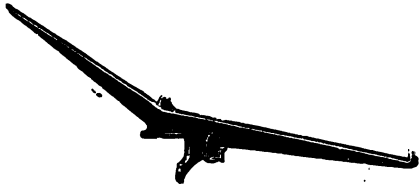

DOUBLE CASE BRACKETS.

Per pair.....\$1 25



GALLEY BRACKET.

Per pair.....\$0.40



SWINGING GALLEY BRACKET.

Per pair.....\$1 00

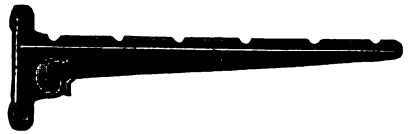

ROLLER BRACKET.]

Per pair.....\$0 50



PRINTERS' LAMP BRACKET.

Brackets, each.....\$0 75

Per dozen.....\$8 00

BINDERS' LIQUID CEMENT.

Red, blue or colorless, for gumming labels, pads and tablets.

Half Pints.....	\$0 35
Pints.....	60
ELASTIC COMPOUND.....	75 40

BLANKETS.

7-col. Hand Press, felt.....	\$4 00
8- " " " ".....	5 00
Cylinder, felt, 44 inch 7/8 yard.....	6 00
" " 47 " ".....	6 50
" rubber, 36 " ".....	8 25

BOOKS.

The American Printer.....	\$2 00
Practical Printer.....	1 00
Wilson's Punctuation.....	1 50
Abbreviated Long Hand.....	25
Suggestions on Punctuation.....	25
Inland Printer, per year.....	2 00
Superior Printer, per year.....	1 00
American Art Printer, per year.....	1 50
Paper and Press, per year.....	2 00

BRASS LEADS.

Twelve to Pica, 7/8 lb., cut.....	\$1 00
Ten " " ".....	90
Eight " " ".....	80
Six " " ".....	75

ELM CITY BRONZING PAD.



Is self-feeding; has no rival. It is an economizer of bronze powder and the most perfect device for bronzing in the market. It receives the bronze in the top which is closed tightly with a slide not shown in the cut and delivers it through valves upon a sieve, in the midst of fine beaver fur, at the bottom. The quantity of bronze to be used can be regulated by opening or closing the valves by means of the thumb-screw at the end of the pad. No bronze escapes except through the bottom.

Large size, 2 1/2 x 6 inches.....	\$2.50
For light work, 2 1/2 inches square.....	1.50

BRONZES.

All Shades and Qualities, 7/8 oz., from 20c to 80c
In pound packages, 7/8 lb.....\$1 00 to \$5 00

CABINETS.

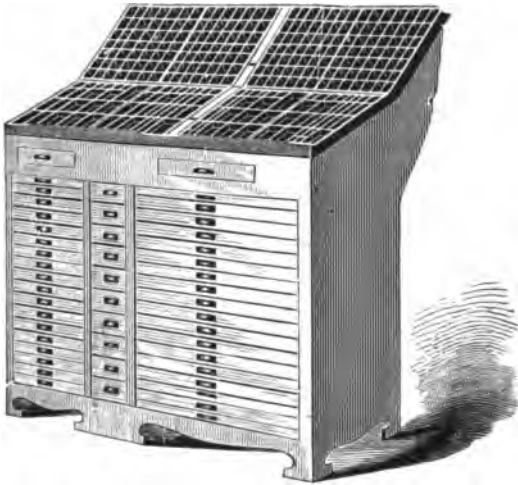

COMBINATION CABINET.

Containing 2 pair news cases, 36 job cases, 10 sort drawers, and 2 copy drawers, \$90 00

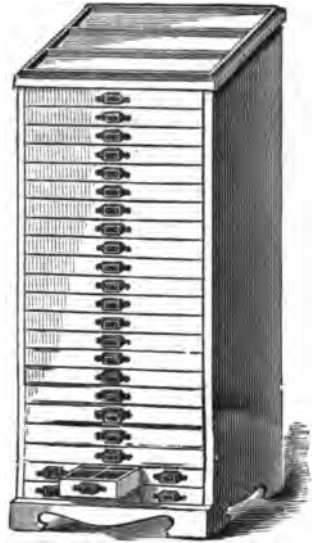

FLAT TOP CABINET.

16-case, $\frac{3}{4}$ size.....\$ 21 50
 20- " " 26 00
 Galley Top, \$ 2 50 extra.

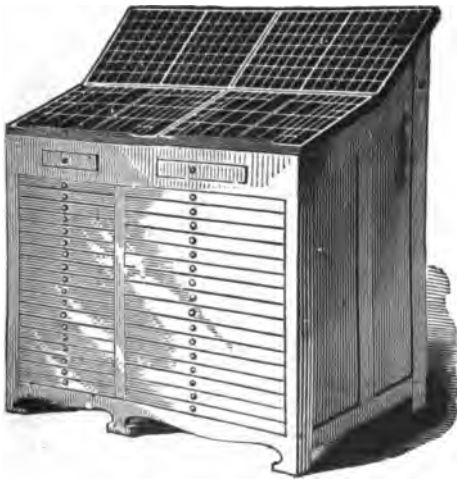

EAGLE CABINET.

Containing 2 pair news cases, 36 job cases and 2 copy drawers.....\$ 75 00



FLAT TOP CABINET.

12-case, $\frac{3}{4}$ size.....\$ 20 00
 16- " " 25 00
 20- " " 30 00
 16- " full " 30 00
 20- " " 35 00
 Galley Top \$ 2 50 extra.



FLAT TOP CABINET.

6-case, $\frac{3}{4}$ size.....\$ 9 00
 8- " " 11 00
 10- " " 14 00
 12- " " 16 00

BLANK CABINETS, FLAT TOP.

16-case, $\frac{3}{4}$ size.....\$ 20 00
 " full " 25 00

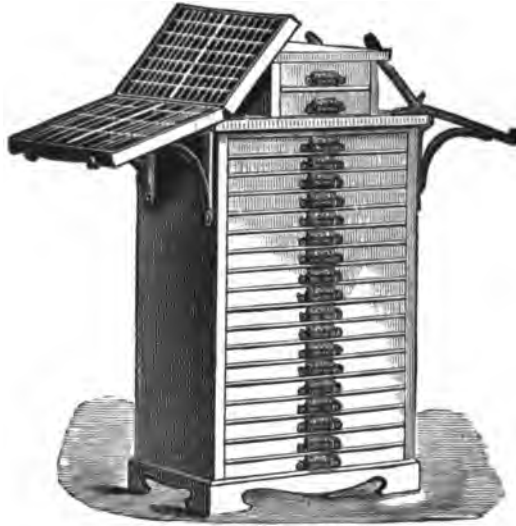

HAWK'S BRACKET CABINET.

18 Full Size Cases, Cherry.....	\$50 00
18 1/4 " " "	45 00
18 1/2 " " "	40 00



SORT CABINET.

Containing 100 Drawers	\$80 00
" 75 "	60 00
" 50 "	45 00



INK CABINET. With Marble Slab, 18x24 inches, \$15 00

CASES.

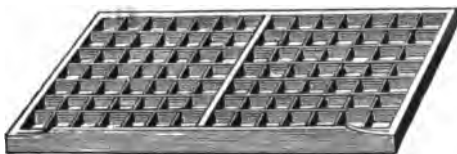

CAP CASE.

Full Size, per pair.....	\$ 1 75
½ " " "	1 60
¼ " " "	1 50

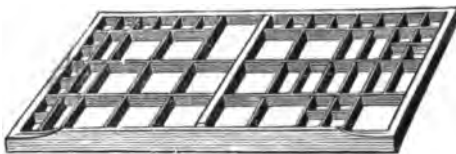

LOWER CASE.

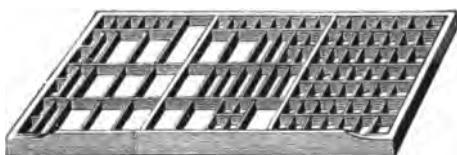

JOB OR ITALIC CASE.

Full Size, each.....	\$ 1 00
½ " "	90
¼ " "	80

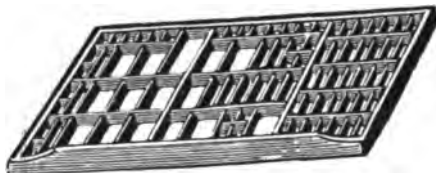

CALIFORNIA JOB CASE.



CHICAGO JOB CASE.

Full Size, each.....	\$ 1 15
----------------------	---------

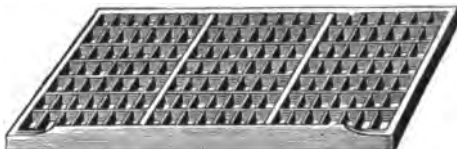

TRIPLE CASE.

Full Size, each.....	\$ 1 00
----------------------	---------



YANKEE JOB CASE.

Full Size, each.....	\$ 1 00
½ " "	90
¼ " "	80

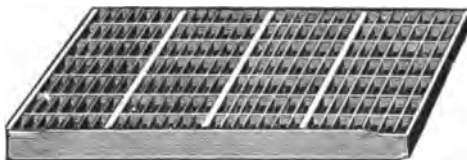

QUADRUPLE CASE.

Full Size, each.....	1 25
----------------------	------

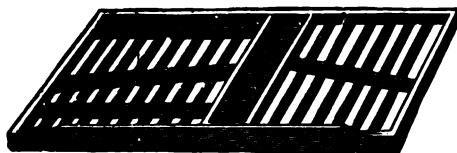

RULE CASE.

Full Size, each.....	\$ 1 50
½ " "	1 40
¼ " "	1 30

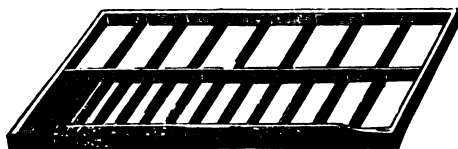

SLUG CASE.

Full Size, each.....	\$ 1 25
----------------------	---------

CASES.

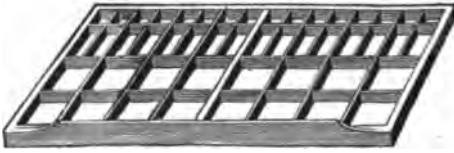

QUAD AND SPACE CASE.

Full Size, each.....\$ 1 25
 1/2 " " 1 00



BLANK CASE.

Full Size, each.....\$ 0 90
 1/2 " " 80
 1/4 " " 70

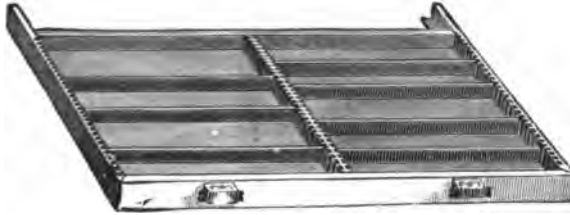

WOOD TYPE CASE.

Full Size, each.....\$ 1 35



METAL FURNITURE CASE.

Full Size, each.....\$ 1 25

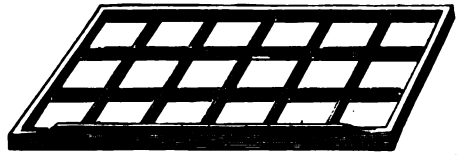
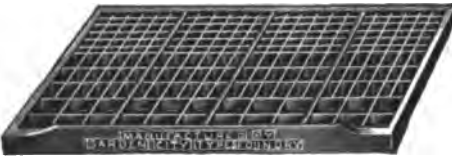

FIGURE CASE.

Full Size, each.....\$ 1 00



BORDER CASE.

Full Size, each.....\$ 1 50

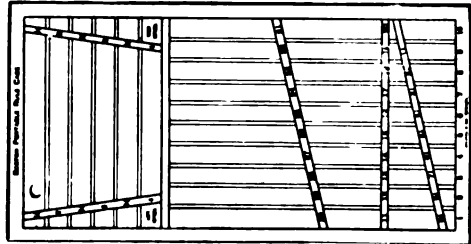

BOSTON RULE CASE.

Each.....\$ 1 00



NO. 1. PLAN OF YANKEE JOB CASE.

This shows the proper way of laying the case, when the space boxes are all in front. Many, however, prefer to retain the old plan of keeping the 4- and 5-em spaces in the top row of the lower part of the fl.

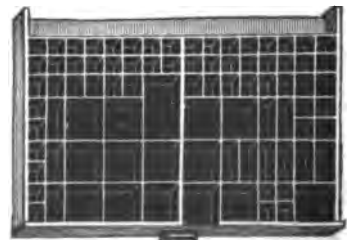

NO. 2. YANKEE JOB CASE.

Shows the old plan. The caps should be laid exactly as in No. 1. Printers having this style of case can change them to plan No. 1 easily, by transferring the partition between the q, x and v boxes over into the t box.

CASE STANDS.

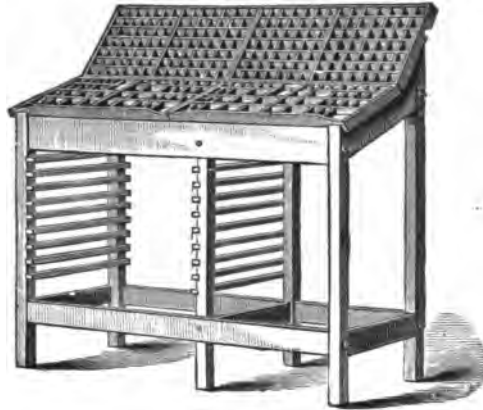

NEWS STAND

News, with rack for 8 cases and 2 pairs up.....\$ 6 00



JOB STAND.

Job, with racks for 12 full and 12 $\frac{3}{4}$ cases, and 2 pair up.....\$ 7 50
 " " " 24 $\frac{3}{4}$ cases and 2 pairs up..... 7 50
 Double, with racks for 24 full cases and 2 pair up..... 8 50

AUTOCRAT STAND.

This is a Printer's Stand or Frame, in its simplest, most compact and most convenient form. The prominent feature is the

GALLEY TRAY

Under each lower case, where the compositor can empty his stick by simply pushing his lower case up sufficiently to expose the galley, after which the case is drawn back to its place.

Every printer who has had galleys of matter piled, or inspected by office loafers, will appreciate and indorse this as a dead-shot to Spy and Pl. The projecting form of lower case support affords a comfortable place to sit or stand, with no cases rubbing against the knees, and insures freedom from interruption of fellow workmen who may want to "set a line."

Each stand will accommodate two pairs of news cases, fifteen full size job cases and six news galleys. On the deck on top, back of the brackets, there is also a large space, which may be utilized for sort drawers or more galleys.



Not only is this the best stand to buy, on the score of convenience, but likewise that of economy. A common news stand, with only six or eight case slides below, costs \$ 8.50 — a total of \$ 15. The Autocrat holds twice as many cases and the same number of galleys, for two-thirds the price.

Autocrat, with racks for 15 cases and 2 pairs up.....\$ 11 00.

BOSTON CARD CUTTER.



These machines are made in a very thorough manner. The upper knife is curved, and is made of the best steel, while the frame is of iron, and the table of hard wood, which is the best surface for moving paper over easily. The front gauge is positive, easily set, and accurate, being controlled by a rack and pinion, which holds the gage exactly parallel with the knife. It has reversible iron back gauge, extending 28 inches from the knife, and a side gauge, which may be placed in three different positions on the table, according to the size of work being cut.

No clamp is required with this cutter, as it has a drawing cut, which keeps the sheets straight. Sheets or strips of any length can be cut, as the standard holding the upper knife has an offset, allowing the inside strip to pass over it and the outside strip under it.
 Cuts 24 inches, boxed.....\$ 21 00
 " 12 " " 13 00

ELM CITY CARD CUTTER.

Reliable and perfect. With a 12-inch blade it will cut a sheet of any size. This was never before accomplished by any machine. A full sheet of card board may be cut on it with as little trouble as on any large machine. It is a good cutter at a price that no office need be without one; and a machine that will do excellent work.



Price.....\$ 10 00



DURANT COUNTER.

No. 1, counts 10,000.....\$ 8 00
 No. 2, counts 100,000..... 10 00

CURVES AND CLAMPS.

The following shows the complete construction of a form containing curved lines held by the improved curves and clamps. The dotted lines are the curves and clamps, the shaded lines the spaces and quads, and the blank space is filled in with plaster.

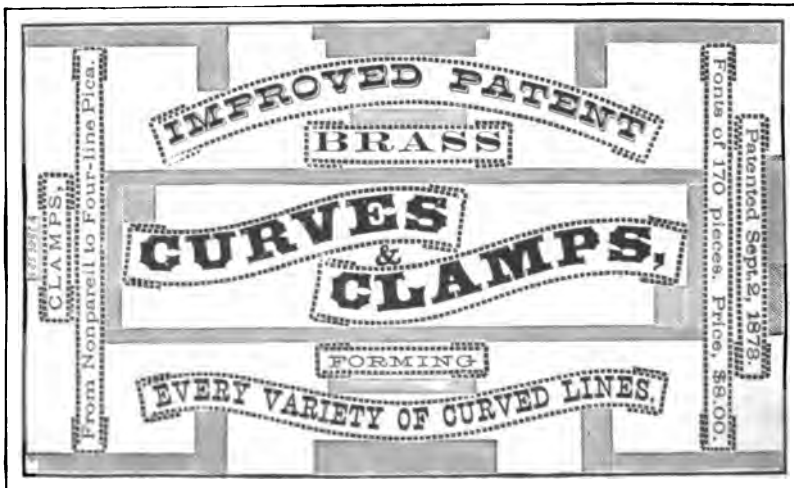

Founts of 170 pieces, \$8 00.

Half founts, \$4 50.

COMPOSING STICKS.



SCREW.

6-inch, 2 inches deep.....	\$0 75
6- " 2½ " "	85
6- " 2¾ " "	90
8- " 2 " "	95
10- " 2 " "	1 15
12- " 2 " "	1 30
Each additional inch.....	15



YANKEE, OR BEVELED SCREW.

Same prices as the Screw stick above.



ALBION.

6-inch nickel-plated.....	\$1 50
8- " " "	1 75



THE BUCKEYE.

6 in. long x 2, 2¼ or 2½ in. deep.....	\$0 80
8 " " 2, 2¼ or 2½ " "	1 00
10 " " 2, 2¼ or 2½ " "	1 20
12 " " 2, 2¼ or 2½ " "	1 40
14 " " 2, 2¼ or 2½ " "	1 60
16 " " 2, 2¼ or 2½ " "	1 80
18 " " 2, 2¼ or 2½ " "	2 00
20 " " 2, 2¼ or 2½ " "	2 20

Lays flat. Quick and easy to set. Will not slip. Warranted accurate.



BOSTON, OR GROVER.

6-inches.....	\$1 10
8- "	1 20
10- "	1 40
12- "	1 60
Each additional inch.....	20



GOLDING'S STANDARD NEWS.

	2-in. deep	2¼-in.	2½-in.
5-inch.....	\$0 85	\$0 90	\$1 00
6- "	90	95	1 05

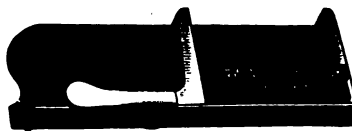

GOLDING'S STANDARD GRADUATED JOB.

6-inch clasp, 2-inch deep.....	\$1 75
8- " " " "	2 00
10- " " " "	2 25
12- " " " "	2 50

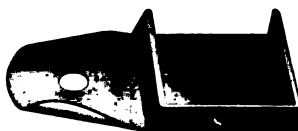

BOSTON NEWS.

These sticks are made to fit the newspaper standard measure—13 ems point system. They are 5 inches long, 2¼ inches deep, and weigh but five ounces. The knee is firmly riveted to the back of the stick and cannot possibly spring.

Price, each.....	\$0 80
Nickel plated.....	1 15



MAHOGANY JOB.

20-inch.....	\$1 15	28-inch.....	\$1 40	36-inch.....	\$1 60
24- "	1 30	32- "	1 50	40- "	1 70

COMPOSING STICK CLAMPS.

Each.....	\$0 20
-----------	--------

CHASES.

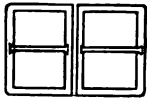

HALF CHASES, WITH BARS.

4-column quarto, 24 x 33 1/4 inches over all, per pair	\$ 14 50
5 " " " 28 1/2 x 33 3/4 " " " "	15 50
6 " " " 32 1/2 x 46 " " " "	18 00

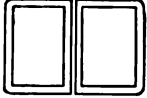

HALF, OR TWIN CHASES.

5-col. folio, 21 1/2 x 29 1/2 in. over all.....	\$ 9 50.
6-col. folio, 24 1/2 x 33 3/4 in. over all, \$10.	8-col. folio, 28 1/2 x 42 1/2 in. over all, \$14
7- " " 25 1/2 x 38 1/4 " " 12.	9-col. " 30 1/4 x 46 " " \$16

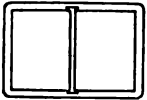

NEWS CHASES.

17x21 inches over all.....	\$5 00	27x39 inches over all.....	\$7 00
20x25 " "	5 50	29x42 " "	7 50
24x30 " "	6 00	30x44 " "	7 75
25x25 " "	6 50	32x46 " "	8 00

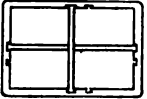

BOOK CHASES.

17x21 inches over all.....	\$8 00	25x35 inches over all.....	\$ 9 50
20x25 " "	8 50	29x42 " "	10 00
24x30 " "	9 00	32x46 " "	11 00

HEADING CHASES, WITH CROSSBAR.

8 1/2 x 19 1/4 size over all; 6x17 size inside....	\$6 50	10 1/4 x 23 1/2 size over all; 8x21 size inside, \$7 00
10 1/2 x 30 1/4 size over all; 8x28 size inside.....	\$9 00	

JOB PRESS.

7x11 inches inside.....	\$ 1 50	10x15 inches inside.....	\$2 50
8x12 " "	1 75	11x17 " "	2 75
9x13 " "	2 00	13x19 " "	3 00
14x29 inches inside.....	\$3 50		

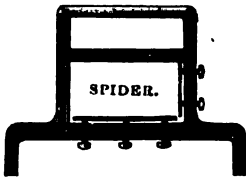

SPIDER CHASES.

For Pearl and Official Presses.

7x11.....	\$ 1 50
8x12.....	1 75

Chases of Special sizes made to order.

IRON SIDE AND FOOT STICKS.

Beveled, for ordinary quoins, 7/8 inch.....	\$0 08
Straight, " patent " "	05

DATE LINES.

Electrotyped from any style of type.....	\$0 75
--	--------

Oakland, Cal. 189

San Francisco, Cal. 189

San Francisco, Cal. 189

Portland, Or. 189

The above three date lines are engraved patterns. We have also engraved patterns for Los Angeles, Stockton, San Jose, Oakland, Sacramento, Fresno and San Diego, and for Seattle and Tacoma, Wash., same style as that of Portland, Or., here shown. Each, 75 cents. Lines engraved to order.

COMPOSING AND MAKE-UP RULES.



Composing, 15 ems and less.....\$0 25
 " each additional pica..... 02
 Make-up, 15 ems and less..... 35
 " each additional pica..... 08

POCKET RULE CASE.

With 10 assorted Rules, 12 to 30 ems.... 1 50

COLUMN RULES.

See Specimen page.

COMPOSITION KETTLES.

Each.....\$6 50

COPY HOLDERS.



Each.....\$0 75

CIRCULAR QUADS.

Per fount of 8 sets.....\$3 50

CORNER QUADS.

Per set of 4, Nonpareil or Pica.....\$0 15

CUTS.

Orders filled from any book, at Prices Quoted.

CURVING MACHINES.



Golding's No. 1, curves ¼ inch to 4 inches
 in diameter.....\$12 00
 Golding's No. 2, curves ¼ inch to 8 inches
 in diameter..... 18 00

ELECTROTYPING AND STEREOTYPING.

Done to order at regular prices.

ENGRAVING.

Engraving executed in the best of style at fair rates.

ENGRAVERS' WOOD.

Boxwood, 7 sq. in.....from \$0 02½ to \$0 08
 Maple, " " " " 01½ " 02

ENGRAVERS' TOOLS.

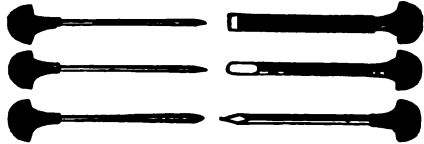

Per set of six.....\$2 50
 Pine Tools, per set of six..... 6 25

THE INDISPENSABLE TRI-PATENT EYELET MACHINE.

FOR CLOTH, PAPER OR LEATHER.



This is the best eyeletting machine in the market, and is simple, durable and rapid. By changing and replacing punches, fasteners and bed, this machine can be used for every variety of work, and will do the work of four machines. When operating with one handle, the other can be raised and thrown out of the way.

All parts can be duplicated. Machine is complete with any one attachment.

PRICE OF MACHINE AND ATTACHMENTS.

Machine without Punch and Set.....\$7 00
 Punch and Set for HLB or HLX Eyelet..... 1 00
 " " " " HLC Eyelet..... 1 50
 " " " " Calendar Eyelet..... 1 50

PRICE LIST OF EYELETS.

Names	Holding Capacity	No. in box.	Price per box.
HLB Common	1-16	500	\$0 20
HLB extra	¼	500	25
HLB double	½	100	17
HLX common (card)	1-32	500	17
HLX " document	¼	250	18
HLX extra	3-16	250	35
LHX double	¼	100	22
HLC common	¼	100	30
HLC extra	3-16	100	40
Calendar	1-16	100	17

SIZES OF EYELETS.

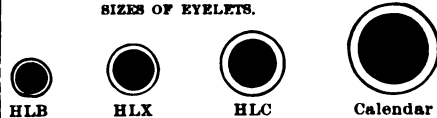

EYELET PUNCH AND SET.

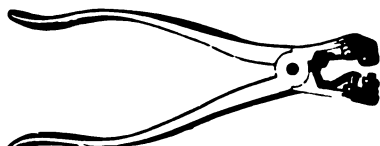

A tool that should be in every office.....\$2 50
 "B" Eyelets, in boxes of 1,000, per box... 25

FURNITURE.



METAL.

In 25 and 50-pound founts, per lb.....\$0 25
Quotations, any weight, per lb..... 30

WOOD.

Cherry Reglet, Nonparell to Great Primer, per yard.....\$0 03
2-line Pica to 5-line Pica Furniture, per yard..... 05
6- " " " 8- " " " " 07
9- " " " 12- " " " " 08
13- " " " 16- " " " " 10
Side Sticks..... 07
Pine Reglet, pay yard..... 02

STEEL FURNITURE.

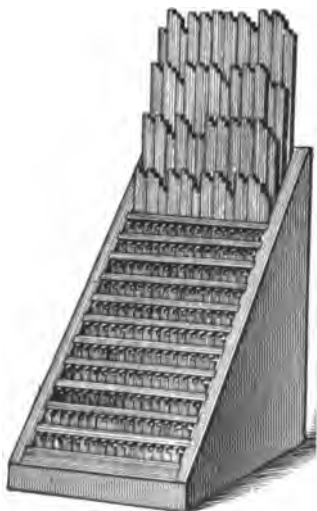

40 Cents per Pound.

It is cut to point system, and every length is an exact pica.

Fount No. 1 weighs 26½ lbs., and contains 44 pieces, 4 of each length from 2 to 12 inches.

Fount No. 2 weighs 53 lbs., and contains 88 pieces, 8 of each length from 2 to 12 inches.

Fount No. 3 weighs 78 lbs., and contains 70 pieces, 6 of each length from 2 to 12 inches, and four of the 15, 18, 20 and 24 inch lengths.

Among the advantages of this material are these: Being of steel it is not easily damaged and will never wear out. Being used in hollow squares, it will fill from four to six times as much space as the same weight of metal furniture. It can be put together in one-quarter to one-sixth the time. It makes a light and accurate form; a square and accurate lock-up. It helps to secure accurate register.

FURNITURE SAW.



12 Inches.

Each.....\$1 50

TAPE FASTENER.



Fastens the tape with an eyelet, which is neatly clinched by the Fastener. A useful tool for pressmen.

Price, including one box of eyelets.....\$1 25

Sent by mail for 16c extra.

FELT CLOTH FOR DISTRIBUTORS.

In rolls, 2½ inches wide, 12 yard.....\$5 00

The same, per yard..... 50

FOOT SLUGS.

Brass, Pica, cut to column.....\$0 10

" Gr. Primer, cut to column..... 25

Metal, " " " 05

" 2-line Pica 06

FEEDERS—PEERLESS.

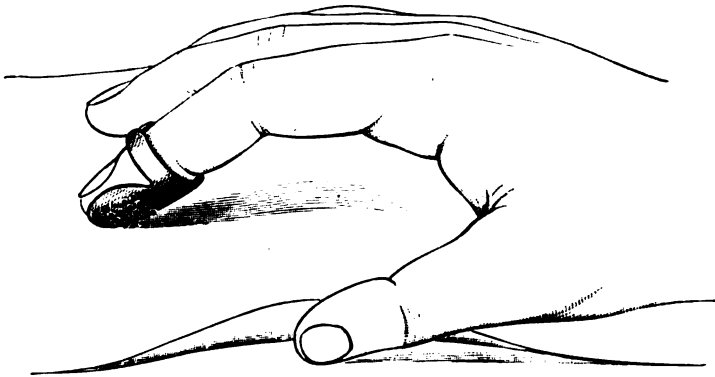

Per dozen.....\$1 25

CYLINDER FEEDERS.

Steel, each..... 50

GALLEYS.



THE DEARING ALL-BRASS GALLEY.

Made entirely from hard-rolled brass without annealing. It is light, solid and strong; made without screws or rivets: It is practically one piece of solid brass. Cannot be injured by lye, steam or water. As the bottom bends over and forms an immovable brace for the sides, it will readily be seen how firm and rigid the whole becomes.

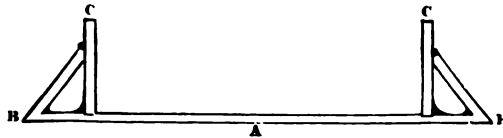

END VIEW OF THE DEARING ALL-BRASS GALLEY.

The bottom of this galley is made of extra-hard rolled brass, of the finest quality, and the sides and end braces are formed from the same piece as the bottom. The sides or upright facing strips are formed of minion rule brass, held rigidly in place by the brace formed from the bottom.

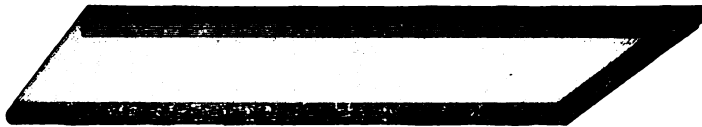

NEWS.

Single column, brass-lined.....\$2 00	Double column, brass-lined.....\$2 50
" " all brass Dearing 2 00	" " all brass Dearing..... 2 75

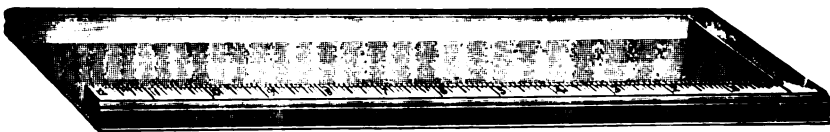

GRADUATED.

These have a scale of Picas clearly marked on the moulding, and will be particularly useful in making up.

6x 9 inches inside.....\$2 00	12x18 inches inside.....\$4 00
8x12 " " 2 50	14x19 " " 5 50
10x15 " " 3 00	16x21 " " 7 00

GALLEYS. (CONTINUED.)



PATENT SEAMLESS GALLEY.

These galleys are made of one piece of metal, doing away with screws, hence having nothing in their construction which can rust and eventually weaken them. In ordinary galleys formed of one piece of metal, with the sides bent up at a sharp angle, the corner so formed is always the weakest part of the galley, and its strength is still further diminished by the necessary cutting away of the metal to form a sharp corner for the type to rest on. In our galley this defect is overcome. The metal bent up to form the sides of the galley extends around the end or head, to which it is firmly soldered, making a strong and stiff corner. We have also devised for use with this galley a very convenient and effective end lock, which can be instantly clamped to the side of the galley in any position.

	Plain.	With clamp.
6x11½.....	\$1 15	\$1 60
8x11½.....	1 30	
6x23½.....	2 00	2 60
8x23½.....	2 25	



JOB.
\$2.00

6 x10, brass-lined.....	\$1 50	10x16, brass lined.....	\$3 00
8½x13	2 00	12x18.....	3 50

\$2.50



WOODEN GALLEYS.

These galleys are made from clear, seasoned cherry, filled with water proof composition.

Job, 4x 6 inches inside.....	\$0 20	News, 2½x24 inches inside.....	\$0 50
" 6x 9 " "	30	" 4½x24 " "	60
" 8x12 " "	40	" 6½x24 " "	75
" 10x15 " "	55		
" 12x18 " "	80		



SLICE GALLEY.

Octavo, Slice, 6 x10.....	\$2 00	Super Royal, Slice, 14x21.....	\$3 50
Quarto, " 8½x13.....	2 25	Imperial " 15x22.....	4 00
Medium " 10 x16.....	2 50	Republican, " 18x25.....	4 05
Royal, " 12 x18.....	2 75		



LIBERTY GALLEY.

This galley is made entirely of brass and very strongly riveted.

Single Column.....	\$2 25	Double.....	\$3 00
--------------------	--------	-------------	--------

GALLEY LOCK-UP.



"LIBERTY" GALLEY LOCK-UP.

This device does away with quoins, side-sticks, shooting-stick and mallet. Is complete and secure and cannot get out of order. Is always ready for use, and neither water nor acids have any effect on it. Lock up so securely that no matter how long locked up, or how many proofs have been taken, the form is always kept tight. Can be made to fit any size galley.

Price, each.....\$1 50

GALLEY RACKS.

The rack is 10 inches wide and the brackets 3 inches apart, excepting the last two, which are 6 inches apart, allowing room for "emptying" or lifting without taking the galley off the rack. The larger sizes are made in the same proportion.

These racks hold a large quantity of matter in a small space.

For 6 galleys... \$3 50
 " 8 " 6 00
 " 12 " 8 50
 Per pair..... 40

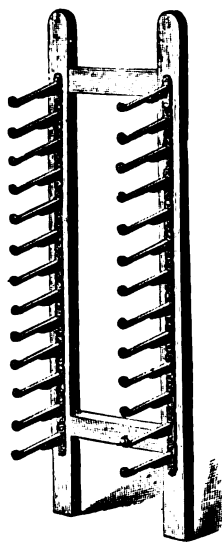
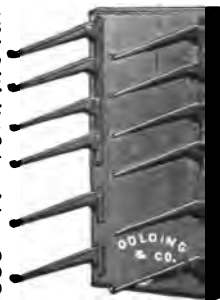

COMMON GALLEY RACK.

For 10 Galleys.....\$ 7 00
 " 15 " 10 00

GALLEY CABINETS.



These cabinets will hold a large amount of matter in a very small space. They are very handy for standing matter in a job office, and are indispensable in book and newspaper establishments. They will take in any galley not over 8 1/2 inches wide.

For 20 Galleys.....\$ 9 00
 " 30 " 13 00
 " 40 " 17 50
 " 60 " 25 00

GAUGE BUTTONS.



This Gauge is attached to the platen sheet with paste, and is easily removed by dropping a little water in the hole in the center, without tearing the sheet. It has three flanges, varying from 1-16 to 3-16 of an inch wide, for narrow or wide margins.

Price, per dozen.....\$0 40

SOLID BRASS GAGES.



An improvement over the old fashioned kind in the shape of a solid brass gauge with a lip to prevent the sheet from slipping off. These are easily kept clean, and cost but a trifle.

Price.....\$0 05

GAUGE PINS.



STEEL GAUGE PINS.

Easily adjusted, and when placed in position are firmly secured to paper by two small teeth.

- No. 1, Pica. No. 3, Great Primer.
- No. 2, Medium. No. 4, Pica, short lip.

Per dozen.....\$0 60

Assorted when required.



SPRING TONGUE GAUGE PINS.

These are pica high only. Each pin has one long and one short tongue. Pins and tongues are both adjusted to a nicety, and the pin is held securely to the paper. The tongue may be bent to suit the different kinds of work.

Each.....\$0 15
Per dozen..... 1 20



PATENT WIRE GAUGE.

Cheap, simple and effective; made of steel wire, with fine ground points. The bend at lower corner prevents the sheets from catching and the pin from working out.

- No. 1, Pica high, for average work, per doz \$0 25
- No. 4, Pica high, for close margin..... 25
- No. 6, 1/4-inch round loop, for wide margin 25
- No. 9, 3/4-inch pointed loop, for bet. lines... 25



GOLDEN STEEL GAUGE PINS.

- No. 1, low gauge. No. 4, low, short peak.
- No. 2, medium. No. 5, med., 1/4-inch peak.
- No. 3, high. No. 6, low, long peak.

The low sizes are best for fine register, and the high for fast feeding. Their cheapness and lasting qualities recommend them to all printers. Manufactured from the best quality of steel.

Price, per dozen.....\$0 40



SINGLE PRONG WIRE GAUGE PINS.

Secured as quick as a flash by simply inserting the prong at the feeding line and forcing it home. The pin will hold in one sheet, and need not be inserted through more unless greater resistance is required. If the margin is extremely narrow, the projection or lip may be lessened by inserting the prong obliquely.

Per dozen.....\$0 20
Per gross..... 2 00

MAGILL'S BRASS GAUGE PINS.

No. 3 and 4, Per dozen.....\$0 40

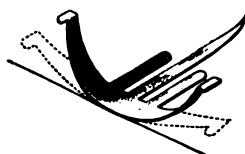

THE FLEXIBLE GAUGE PIN.

This is the latest improvement in gauge pins. It can be worked directly under the grippers without danger of being smashed. It is also very handy in feeding curled or wrinkled sheets. It can also be used between the platen and roller ways. It is made in three styles: No. 1, Low Bottom-Gauge; No. 3, High-Bottom Gauge; No. 4, Side-Gauge.

Per dozen, assorted.....\$0 75
Per set..... 25



1-8 Inch.

GRIPPER-FINGER.

Attached to any gripper. Immovable on the grippers. Any sheet removed. Besides the 1/4-inch Between-Line we make four other forms of Grippers:

- 1/2-inch Between-Line for wider spaces.
- Hair-Margin that will nip a label or other sheet cut to the border, which saves paper and after-trimming.
- Short-L for gripping from below the sheet.
- Long-L for lengthening the grippers and preventing large sheets from dropping over on the ink-disk or rollers.

In ordering SPECIFY WIDTH OF GRIPPEBS. Otherwise, a size fitting the average gripper (1 inch) and securable on all sizes under it, will be sent. Measure across the lower part of grippers.

Outfit of 10 pieces (1 pr. of each) either size \$3 00
Pair of fingers, either form or size..... 75
Single " " " " " 50



IMPROVED EXTENSION FEED GUIDE.

These are designed for printing large sheets requiring a gauge beyond the lower edge of the platen, and are secured to the platen bands.

Per Set, including extra pair of short guides and tongues.....\$1 00

MAGILL'S RADIATING GUIDES.

3 1/2 inch.....\$3 10

HEADINGS FOR NEWSPAPERS.

Electrotyped from any pattern, \$ 2 00 to \$ 5 00
 Engraved to order..... 10 00 to 50 00

INKS.

Black and Colored, all kinds, at maker's list prices. A full stock kept on hand.

INK KNIVES.

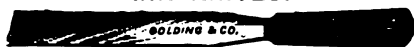

6-inch blade.....	\$0 60
8- " "	75
10- " "	1 15
12- " "	1 75

INK SLICE.

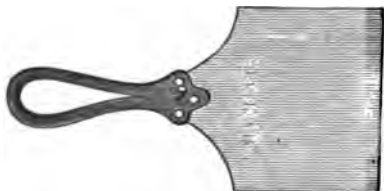

Each.....\$0 75

INK BRAYER.



The best implement for thoroughly mixing inks.
 Price, each.....\$0 25

INKING APPARATUS.

Including 2 cylinders, roller handle and 2 roller cores, complete—

For 7-column press.....	\$22 50
" 8- " "	25 00
" 9- " "	27 00

INK SLABS.

Glass or Marble, per square foot.....\$2 00
 Set in Tray, extra..... 1 00

Made any size.

INK FOUNTAINS.—CHANDLER & PRICE.

Price.....\$20 00

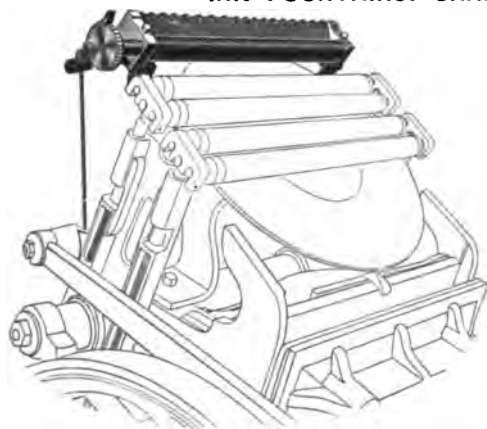

To those whose special work requires greater capacity than can be obtained with the Buckeye, we offer the Chandler & Price Fountain, which is so made as to permit contact with the rollers the whole length, and will thus furnish a greater supply of ink than the Buckeye. Its construction and operation will be readily understood from the Cut, which shows it attached to a 14 x 20 Chandler & Price Press. It is without all extra and useless parts which complicate and add to the difficulty of using, and at the same time is complete with all the requisites of a first-class fountain.

BUCKEYE INK FOUNTAIN.

Price.....\$10 00

This fountain will be found the easiest attached, easiest worked and most practical ink fountain in the market. Its roller is so adjusted as to supply ink uniformly on either a large or small job. Its size also makes it practical to use expensive ink without waste, only a small amount being required to fully supply the fountain. The bottom is so constructed as to permit all the ink to run down to the roller, there being no pocket or dead space. By turning the pawl from the ratchet wheel, the operation of the fountain is suspended without missing an impression.



INK FOUNTAINS—PEERLESS.



HINGED WELL INK FOUNTAIN.

When properly used it will carry an even color for any length of time. Can be easily cleaned and is so simple that any boy can use it. It can be raised or lowered by the use of the large screw, so as to give more or less contact with the distributing roller. The fountain roller can be adjusted by operating the screws on the top of the fountain, on either side, so that the required quantity of ink may be fed to the distribution roller.

Price.....\$25 00.

CYLINDER DISK DISTRIBUTION.

The Johnson cylinder-disk distribution shown in this cut is a combination of cylinder and disk distribution in its simplest form. Thorough distribution is obtained by its use. When less ink is desired the distributor can be removed, also the ink cylinder, if necessary. The fountain can be raised entirely clear of the form rollers by means of a large screw on the side.

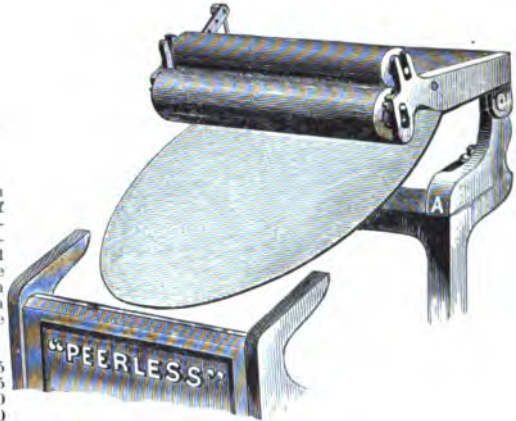

14½x22 press, \$50	11x17 press, \$45
14 x20 " 50	10x15 " 45
13 x19 " 50	9x13 " 40
	8x12 " 40

IMPOSING STONES AND FRAMES.

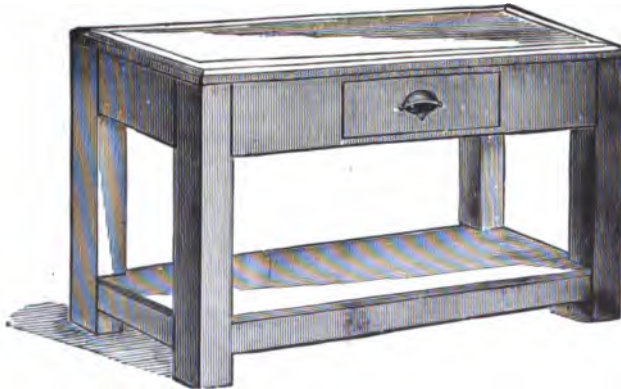

Tables for 2 pages.....	\$10 00
" " 4 "	12 00

Size in Inches.	No. pages.	Size of Paper.	Marble Stone with Table.	Marble Stone in Tray.
26x44	2	7 column folio.	\$23 00	\$15 00
28x50	2	8 " "	25 00	20 00
30x60	2	9 " "	33 00	25 00
20x72	4	7 " "	38 00	30 00
28x80	4	8 " "	40 00	33 00
30x90	4	9 " "	45 00	35 00
36x60	4	6 " quarto.	42 00	33 00

Marble is nicely surfaced, and set in plaster in the trays.

Marble Slabs of any special size furnished to order, either with or without tray.

INKOLEUM.



Lightning ink reducer and dryer.

It is colorless, and refines ink of any color without affecting the most delicate tints and makes all inks dry quick and glossy on paper but never on rollers.

Inkoleum gives pressmen complete control over job and cylinder presswork, rollers, ink, paper pulling at form, cuts that fill up, etc., cold mornings or damp hot air.

Price, per bottle.....\$0 50

KNIVES.

Printers' Knives, each.....\$2 00

LEADS AND SLUCS.

Accurately shaved, 18 inches in length, and put up in packages of 10 lbs. Sold in any quantity.

12-to-Pica, 7 lb.....	\$0 80
8- " " ".....	30
6- " " and thicker, 7 lb.....	18
Cut to order, 7 lb.....	18
Cut labor-saving, 7 lb.....	25

LEADERS.

Brass, 6-point, 7 lb.....	\$1 60
" 8- " ".....	1 60
" 10- " ".....	1 50
" 12- " ".....	1 40
Copper-Alloy Metal, 6-point, 7 lb.....	76
" " 8- " ".....	64
" " 10- " ".....	56
" " 12- " ".....	52

Brass and Metal Leaders are made to line with any face, on special order. They are kept in stock to match our Law and Legal Italic.

LEY.

H. & S. "Hell Fire" Type Wash, 7 lb.....\$0 20

LABOR-SAVING LEADS.

Accurately made and cut into graduated lengths, from 4 to 25 ems Pica.

Saxon, or thicker, in 20 lb founts, 7 lb.... \$0 25

LABOR-SAVING SLUCS.

Smooth and perfect, accurately cut from 4 to 25 ems Pica.

Nonpareil or thicker, in 25 lb founts, 7 lb, \$0 25

LABOR-SAVING BRASS RULE.

The rules are accurately cut to Pica ems, 1 to 10 ems by ems and ens, and from 10 to 25 ems by ems. All founts contain an assortment of mitres.

Saxon, or 6-to-Pica, 7 lb.....	\$2 00
Brilliant, or 4-to-Pica, 7 lb.....	1 75
Excelstor, or 3-to-pica, 7 lb.....	1 60
Pearl, or 5-point, 7 lb.....	1 60
Nonpareil, or 6-point, 7 lb.....	1 50
Larger sizes, 7 lb.....	1 50

We keep in stock faces Nos. 222, 319, 253, 234, 235 and 236, as shown in specimen pages. Other faces cut to order.

Rules mitred to order.

EUREKA LABOR-SAVING LEAD AND SLUC RACK.



Holds from 4 to 28 ems in length.

Price.....\$3 00

GOLDING'S LABOR-SAVING LEAD AND SLUC RACK.

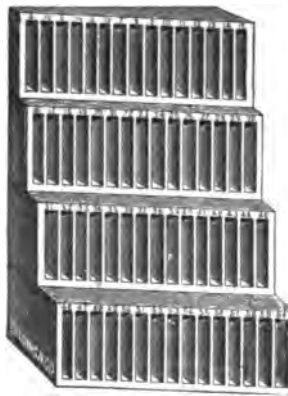

They are made in four sections with varying sizes, from 4 to 60 ems Pica, as shown in accompanying cut, with the length of the leads or reglets plainly stamped on the top of each compartment. Each rack is 16 inches long and 6 1/2 inches high.

	Without reglet.	With reglet.
No. 1, holding 4 to 15 ems.....	\$1 00	\$2 50
" 2, " 16 to 30 ".....	1 30	3 80
" 3, " 31 to 45 ".....	1 60	5 10
" 4, " 46 to 60 ".....	1 90	6 40

LABOR-SAVING WATERPROOF CHERRY REGLET.

Nonpareil and Pica, 25 pieces of each size, in founts.

	Nonp.	Pica.
Fount No. 1. 4 to 15 ems long...\$	80	\$ 80
" " 2, 16 to 30 " " ...	1 30	1 30
" " 3, 31 to 45 " " ...	1 80	1 80
" " 4, 46 to 60 " " ...	2 30	2 30

THE LABOR-SAVING FURNITURE RACK.



Full Size.



Half Size.

This furniture is perfectly true and accurately cut, from 10 to 60 ems long, well oiled, and made 2, 3, 4, 5, 6, 7, 8 and 10 ems wide.

Half fount, with case of 280 pieces.....	\$ 7 00
Single " " " 560 "	10 00
" " (without case) 560 pieces.....	8 00
Double " with case of 1,120 pieces.	16 00
" " (without case, 1,120 pieces.....	41 00

NEW LABOR-SAVING REGLET CASES.



SIZES AND PRICES.

- No. 3, contains 4,200 pieces 550 yards oil-soaked cherry reglet, half pica and half Nonpareil, cut from 10 to 51 ems long, 100 pieces of each length, varying one Pica only.....\$ 15 00
- No. 4, contains 2,100 pieces 275 yards oil-soaked cherry reglet, half Pica and half Nonpareil, cut from 10 to 51 ems long, 50 pieces of each length, varying one Pica only.....\$ 8 00

BRASS LABEL-HOLDERS.



These holders improve the appearance of the office; obviate all liability of the labels dropping off; facilitate in the selection of lines; save time, labor and patience in both composition and distribution.

PRICES.

1x5 1/2 inches, including cards and tacks, per dozen.....	\$ 0 35
" " " " " " " " 100.....	2 50

LITTLE GIANT LEAD AND RULE CUTTER.



Admitted by all to be the best machine in the market for cutting both rules and leads.

Nonpareil rule may be cut with the utmost ease on Nos. 1 and 2, and Long Primer rule on No. 3; and for cutting leads it has no superior.

It has a balanced handle, large bearings, powerful action, and is held at the head when cutting, so that it is impossible for the knife to spring from the work. The back gauge is reversible, so that, while the bed on a No. 1 Cutter is only eight inches long, a rule may be cut to a gauge twelve inches long. There is a front gauge for cutting narrow pieces of lead or rule, which is especially useful in cutting leads swiftly.

No.	Sizes and Prices.
1.	Gauges 12 in.....\$ 8 50
2.	" 12 " graduated to Picas 9 50
3.	" 18 " " " 12 50

CURTIS AND MITCHELL'S LEAD CUTTER.



Price.....\$2 50

MITERING MACHINE.



CHANDLER & PRICE'S MITERER.

Perfectly miters all kinds of brass or metal rule. The knife is made of the best steel and is easily removed and sharpened.

Price.....\$16 00

PRINTERS' VISE.

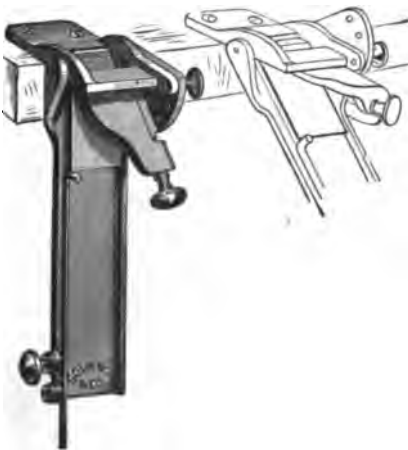

This is a convenient tool for filing rule at either angle of 45, 67 1/2, or 90°. The surfaces controlling the angles are hardened so that the file will not scratch them. The rule is held by a screw clamp, and the length is controlled by a reversible gauge extending eleven inches.

Price.....	\$2 50
Files, second cut, 8 inches.....	25
" smooth " 8 "	30



GOLDING'S UPRIGHT MITERER.

Price.....\$14 00

MUSTANG MAILER.

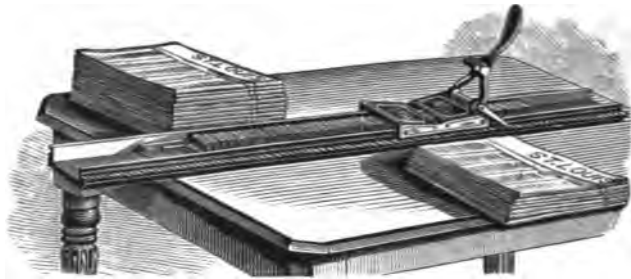

Its cheapness, simplicity and durability recommend it to publishers, and also to every business house having a large mail list.

The great advantage of this machine over others is that it prints directly upon the paper or wrapper, and does away with pasting. Where labels are used there is a liability of their being pulled off, in which case the matter mailed fails to reach its intended destination and is therefore lost, as well as the postage.

Another matter to be taken into consideration by those contemplating the purchase of a mailing machine is the cost. Purchasers of the Mustang are subject to no further expense after the first outlay, there being no royalty to be paid the patentee or manufacturer.

The Mustang Mailer occupies a space of 37 inches in length and 4½ inches in width, is made wholly of iron, without springs or complications of any kind to get out of order, and can be operated by a boy as easily as a man. They are capable of printing addresses at the rate of from 1,500 to 2,500 an hour, according to the expertness of the operator. The mode of operation is so admirably and effectually illustrated in the above engraving that it is deemed unnecessary to give an extended description.

The mail list is imposed made up upon galleys 1½ inches 10 ems Pica in width on the inside. Each galley will contain 75 to 80 addresses, is easily accessible for the purpose of making corrections, and convenient for handling.

The weight of the machine is only fifteen pounds, and galleys one pound each, making their transportation to any part of the country, by express, but a small item.

COST OF AN OUTFIT FOR A LIST OF 1,000 NAMES.

Mailer.....	\$ 11 00
13 Galleys.....	6 50
1,000 Reglets.....	2 00
75 lbs. Long Primer.....	34 50
10 lbs. Post Office Type.....	7 40
Total,	\$ 63 70

METAL REGLET, OR SLUGS.

Nonpareil, for use in Mailing Galleys, or Newspaper Headings, in place of Wood Reglet, 24 inches, each\$0 15

NEWSPAPER HEADINGS.

Electrotyped from any pattern, \$ 2 00 to \$ 5 00
Engraved to order..... 10 00 to 50 00

MALLETS.



Hickory, small.....\$0 40
" large..... 50

TYPOGRAPHIC NUMBERING MACHINE.



A numbering machine designed to be composed together with and surrounded by ordinary type, rules, etc., locked in a chase and operated in any printing press. At each impression the number automatically advances in consecutive order from 1 to 100,000.

Entirely self-acting. Requires no attachments. All parts steel. Composes in minimum space. Is constructed without a plunger, thus avoiding the necessity of using "frisket" sheets and the cutting of ink rollers.

MITRE BOX AND SAW.



Mitre Box.....\$0 50



12-inch Back Saw.....\$1 50

Price\$30 00

BATES AUTOMATIC NUMBERING MACHINE.

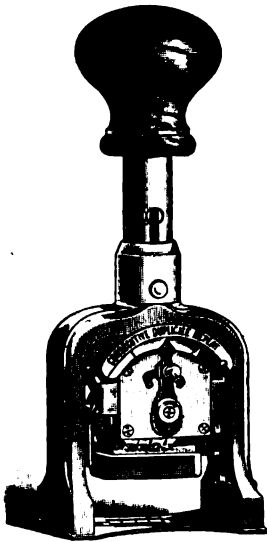

This machine is capable of absolutely accurate work, combines the minimum of size and weight with the maximum of durability and simplicity of operation, and will be sold at a low price.

It weighs scarcely fourteen ounces, and is built upon an entirely new principle, making it small and light to handle, thus insuring speed and ease of operation. It works with very little friction, and therefore, without noise. The frames are substantial iron castings, highly polished and nickel-plated. Every wearing part is made of steel, including the figure-wheels, and all parts receive the finest finish and are interchangeable to the smallest screw.

PRICES:

With four wheels, numbering from 1 to	9,999.....	\$ 14 00
" five " " " 1 to	99,999.....	16 00
" six " " " 1 to	999,999.....	18 00
" seven " " " 1 to	9,999,999.....	20 00

These prices are for machines made with any of the styles of figures shown, and apply to either style of machine—Automatic or Lever Movement. Prices for letter wheels upon application.

Each machine is guaranteed in every particular; is carefully packed in a wooden box with a bottle of ink, and will be forwarded to any address in the United States on receipt of price. Directions for operating accompany every machine.

STYLES.

Style A 12345	Style B 12345	Style C 12345	Style D 12345
Style E 12345	Style F 12345	Style G 12345	Style H 12345

Any size or style of figures will be made to order.

THE MONARCH NUMERATOR.

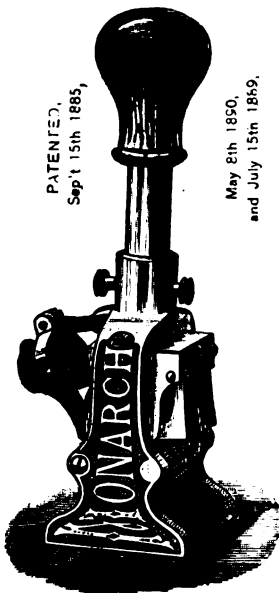

Finest Finish, Steel Wheels, Triple Action. Duplicating, Repeating and Consecutive.

The attachment for changing the different actions for numbering have been simplified to prevent any mishap through inexperience in operating. The inking attachment is entirely new, having a more direct and straight action of the ink pad to the figure wheels patented, also being more compact, producing a lighter, stronger and easier working machine. The frame and wheels are of steel highly finished, and nickel-plated throughout. It is the most simple machine extant, without complicated attachments to be continually getting out of order. Machines supplied with 4, 5, 6 and 7 wheels.

Machines numbering to	9,999.....	\$ 14 00
" " "	99,999.....	16 00
" " "	999,999.....	18 00
" " "	9,999,999.....	20 00

STYLES.

Style C. 1234567890	Style D. 1234567890	Style E. 1234567890
------------------------	------------------------	------------------------

NEWSPAPER FILES.

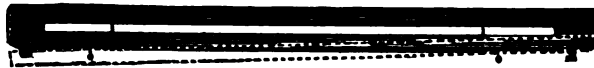

HAMILTON FILE.

To hold sheet 24, 26 or 28 inches wide, each.....\$1 25

ATWATER FILE.

To hold sheet 24, 26 or 28 inches wide, each.....\$ 50

OIL CANS.



Tin.....\$0 25
Brass.....40

PRESS OIL.

Hawks & Shattuck's Anti-Gumming Press Oil is the best oil for presses, gas and steam engines, etc. While of good body, it works smooth and easy, and positively WILL NOT GUM. Try it.

In gallon cans.....60 cents per gallon
In 5-gallon cans.....50 " "

Special rates in barrel lots.

PAGE CORD.

Per ball.....\$0 40

KENNEDY'S' HAND PASTER.



This machine is so constructed that the flow of paste can be regulated. It can be carried in the hand, between the thumb and the fore-finger without any inconvenience, while the sheets are being folded.

Price, including two wheels and four gates, \$3 50

PLANERS.

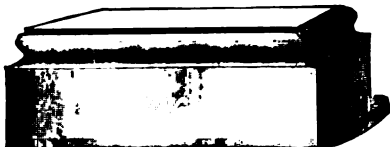

Small.....\$0 40
Large.....50
Proof Planers.....75

POINTS.

For Hand Presses, 7 pair.....\$0 50

PERFORATING RULE.

Steel, 7 foot.....\$0 75
Brass " ".....25

ST. JOHN PAPER KNIFE.



Made of fine steel and suitably pointed for paper cutting.

A very useful article in a printing office.

Price.....\$0 50

PAD COUNTER.

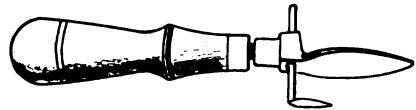

With this tool, the adjustable tongue having been once set to the thickness of the number of sheets desired, the whole job can be divided into pads of an equal number of sheets, without counting.

Price.....\$1 50

PRINTERS' PUNCH.



This punch is for cutting holes in ball programmes, etc., and where cards are laced together with silk or ribbon. They are handsomely and strongly made, nickel-plated, and can be furnished in any of the following shapes:



4 3 1 5 2

Price, each.....\$2 50
Also, cheaper grade.....1 25

ROSBACK PERFORATOR.

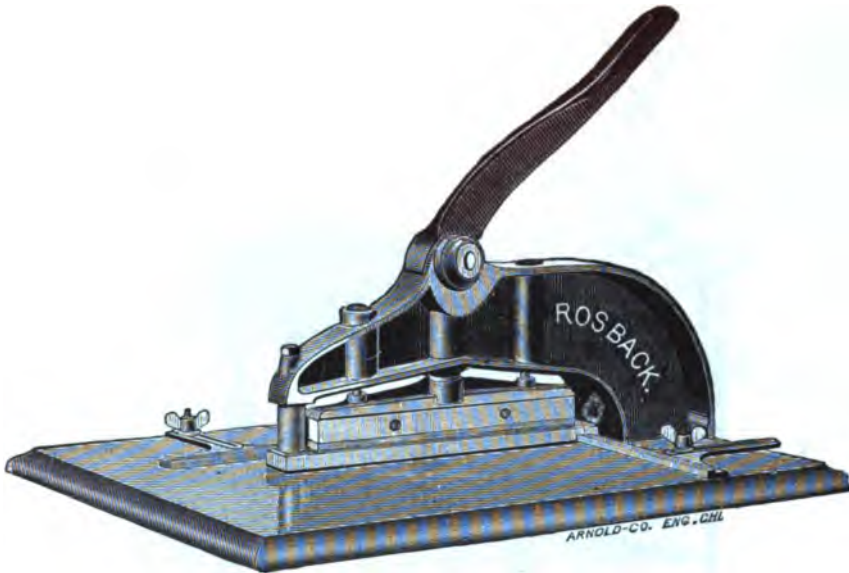

This machine does its work well; is simple and strongly constructed; has side and front gauges; the table which holds the work is 20x20 inches.

This machine will supply a want felt by hundreds of printers whose work does not justify them in purchasing the very expensive machine used by bookbinders.

It is large enough to perforate five checks without turning; has a fine cherry table, is light and durable. The perforations are round, as on postage stamps, and are large enough for any check book. In case of accident to the needles, they can be readily replaced at but a trifling cost.

Perforates 10 inches, Price.....\$37 50

THE STERLING FOOT PERFORATOR.



A strong, simple, durable machine, at a price within the reach of every printing office. Has side and back gauges. It has a larger table for handling stock than any other perforator. Is made of the finest steel, brass and iron, and warranted the equal in construction of any perforator in the market. Has special points of excellence that invite attention. Enables the country office to retain local business which goes elsewhere when home facilities are lacking.

Perforates round holes like postage stamps. Perforates ten inches, with five inches space for stubs. Perforates three sheets at a time better than it will one. No more smeary perforating with rule. No more customers driven away by disfiguring perforations. No more rollers ruined by perforating rules. No more vexation, bother, and loss of time, trying to do half decent work perforating on the press.

Price, crated.....\$ 50 00

Special boxing, when desired, 3 00

THE SEDGWICK PAPER JOGGER.



Is an attachment, for Cylinder and Adams Presses, for jogging or straightening the paper after it is delivered from the fly. It works automatically with the fly, and will jog any weight or quality of paper except a tissue better than it can be done by hand.

They are made to fit on all kinds of presses, and are all made so that they are adjustable to any size sheet—from the largest the press will print to 8 inches square. They can be adjusted in a minute, by means of the thumb-screw on the gauges, to take any size sheet, and are made to jog paper $3\frac{1}{2}$ inches high.

PRICE OF JOGGER, IN S. F.

To fit presses 24x36, or less.....\$18 00 To fit press larger than 24x26.....\$20 00



22 $\frac{1}{4}$ - and 25-inch Paragon.

PARAGON PAPER CUTTER.

The lever works over the table, but so curved as not to interfere with the handling of any length of paper in front of the knife. They have back and side gauges, and solid iron frames, table and stand. They have a measuring rule on the front table. The back gauge can be set within $\frac{1}{4}$ inch of the knife. The knife is made of the best quality of steel, and is easily adjusted by screws.

PRICES:

Cuts 14 inches, weight 200 lbs.	\$ 45 00
" 22 $\frac{1}{4}$ " " " 150 "	80 00
" 25 " " " 550 "	110 00

Freight from factory to be added.



14-inch Paragon.

ECONOMIC PAPER CUTTER.

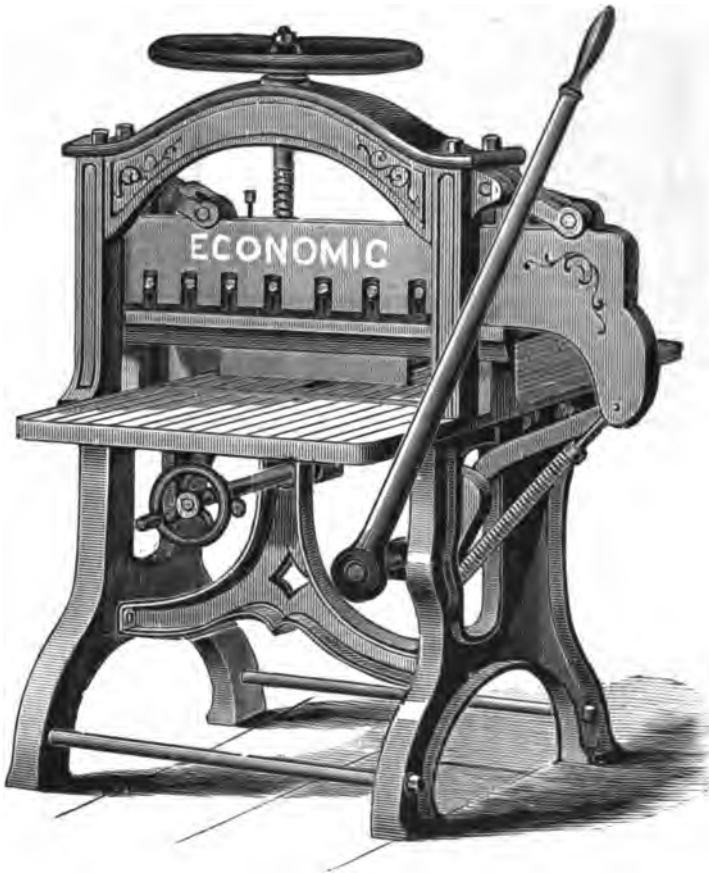

The best low-priced paper cutter in the market. This machine is designed to meet the demand of printers who want a good paper cutter at a low price. It is very simple in construction, yet it is powerful, strong, and as well built as any high-priced cutter. Every machine warranted.

24-inch.....\$ 135 00 30-inch.....\$ 175 00 32-inch.....\$ 200 00

Boxed and Shipped Free of Charge in San Francisco.

JEWEL PAPER CUTTER.



A perfect and thoroughly reliable cutter for printers' and bookbinders' use. Iron bed and table marked off in parallel lines, and measuring rules stamped on each. Both bed and table have side gauges, and the bed a back gauge, operated by a screw and crank wheel at the front of the machine. It has all the modern conveniences now in use on lever paper cutters. Strong, powerful, easily understood and operated, and will do its work as satisfactorily as any cutter made. The knife is operated by the end lever device.

PRICES.

30-Inch.....\$ 150 00
 Boxing..... 8 00
 23-Inch..... 90 00
 Boxing..... 5 00

Freight from factory to be added.

PEERLESS PAPER CUTTERS.



PEERLESS FRONT LEVER CUTTER.

30-Inch.....\$ 175 00
 32- " 200 00



PEERLESS END LEVER CUTTER.

30-Inch.....\$ 200 00
 32- " 225 00



PEERLESS POWER CUTTER.

Strong and durable; simple in construction; best workmanship; best material; greatest power.
 32-Inch.....\$ 450 00 36-Inch.....\$ 600 00 40-Inch.....\$ 700 00
 Freight from factory to be added.

GEM PAPER CUTTER.

This cutter is a simple, durable and perfect hand-machine. It possesses great strength and is very heavy, compact, firm and rigid; works smoothly and easily; knife cuts perfectly true; windlass-clamp has a free and quick motion; the cutting sticks of wood in table receive knife; table is divided into lines, squares and inches; has back and side gauges.

An inspection will convince any one of the superiority of the "Gem."

We can refer to very many sold and in use all over the United States for many years, which give perfect satisfaction.

SIZES AND PRICES, IN S. F.

Cuts 30 inches, weight, 1,200 lbs.....\$ 200 00
 " 32 " " 1,500 " 225 00

Above prices include Boxing.



COLT'S ARMORY JOB PRESS.



The most durable and economical. The best material and workmanship. The strongest press made. Exceptional strength and rigidity. All parts proportionately designed. Excellent distribution. Speed fast as desirable. Easy operation by treadle. Large wearing surfaces. Noiseless in operation.

PRICES AT FACTORY.

8x12 inches inside of chase.....	\$225 00
10x15 " " " "	320 00
13x19 " " " "	415 00
14x22 " " " "	480 00
Steam Fixtures, extra, for any size.....	15 00

Ink Fountains: Eighth, \$18; Quarto, \$20; Half Medium and Half Super Royal, \$25.

Included with each press, are: three chases, one roller mould, six form roller and four distributing stocks, twelve roller wheels six large and six small one regular changer, two feed tables, one socket and one small and one large impression wrench.

CHANDLER & PRICE OLD STYLE GORDON PRESS.

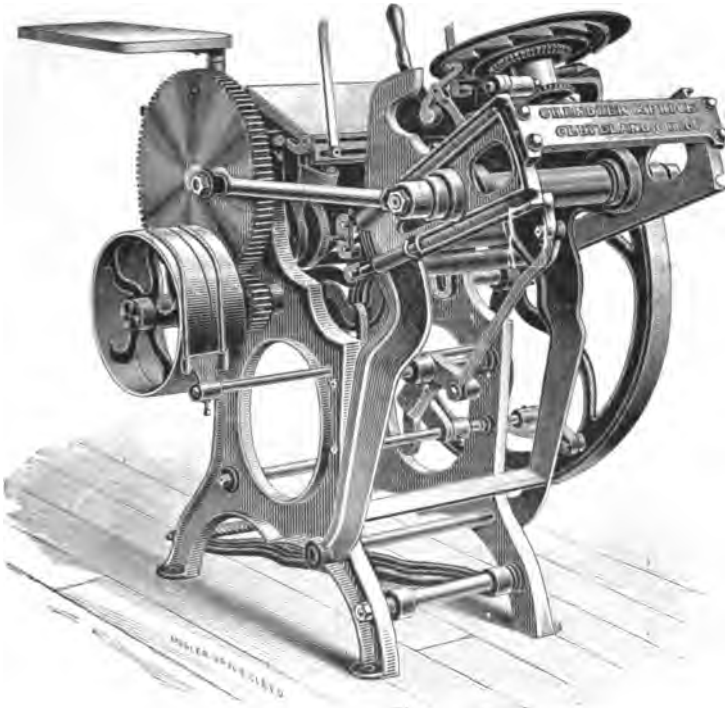

Eighth Medium, 7 x11, with Throw-off and Depressible Grippers.....	\$170 00
" " 8 x12, " " " "	190 00
Quarto " 10 x15, " " " "	280 00
Half " 14 x20, " " " "	425 00
" " 14 1/2 x22, " " " "	450 00
Steam Fixtures.....	15 00
Chandler & Price Fountain, for either size press.....	20 00
Buckeye Fountain.....	10 00

With each press there are three chases, one brayer, two sets of roller stocks, two wrenches and one roller mould.

SPECIAL FEATURES.

Steel shaft and steel side arms, forged from solid bar, without seam or weld. The most positive and practical throw-off yet introduced. Best material used. Most carefully finished. Hardened tool-steel cam rollers. Depressible grippers.

These presses have been recently greatly strengthened, the disk and roller carriers being so arranged as to give greatly increased distribution. One of the most durable, most reasonable in price, and most economical presses for the printer yet manufactured.

THE PEARL PRESS.



The Pearl is acknowledged by practical printers to be the best printing press for the price ever invented, and it has no superior at any price for ease and rapidity of motion, beauty of design and finish, thorough mechanical construction and compactness. The Pearl combines everything that can be reasonably asked for in a printing press at a moderate price.

SIZES AND PRICES.

No. 1, 5x8 inches inside chase.....	\$ 70 00
No. 2, 7x11 " " "	110 00
No. 5, 9x14 " " "	180 00

Freight from factory to be added.

The iron cabinet or press stand is made in keeping with the substantial character of the press, both forming a firm and beautiful structure from top to bottom, and affords packing room for tools, stock and material. Its upper drawer receives cards from the card dropper.

Two machine rollers, hand roller and ink table, gauges, two chases and a wrench are included with every press. Also extended shaft for attaching steam fixtures.

Weight, boxed, with iron cabinet, No. 1, 300 lbs; No. 3, 500 lbs; No. 5, 900 lbs.

PRICE-LIST OF EXTRAS.

	No. 1.	No. 3.	No. 5.
Chase, Common.....	\$ 0 70	\$ 1 25	\$ 1 50
" Screw.....	1 10	1 50	2 00
" Spider.....	1 00	1 40
Card Dropper.....	4 00	4 00
Ink Fountain.....	9 00	9 00	10 00
Rollers, each.....	75	80	1 20
Roller Cores, each.....	50	60	70
Roller Mould.....	2 50	3 00	3 25
Steam Fixtures.....	10 00	10 00	12 00
Boxing.....	2 00	3 00	4 00

PEERLESS JOB PRESS.



SIZES AND PRICES.

Eighth Medium, 8 x12 in. inside chase,	\$225 00
" " 9 x13 " " "	250 00
Quarto " 10 x15 " " "	300 00
" " 11 x17 " " "	350 00
Half " 13 x19 " " "	400 00
" " 14 x20 " " "	450 00
" Super Royal 14 1/2 x22 " " "	500 00
Steam Fixtures.....	15 00

Freight from factory to be added.

Three chases, six roller stocks, one roller mould, one impression wrench, one gripper wrench and one brayer, shipped with each press.

PILOT JOB PRESS.



These presses rank as the best of this class in the market. They are strong, easily operated and have all the essentials of a thoroughly good and practical printing press. The size, 8 1/2 x10 inches inside chase, embraces all ordinary commercial printing.

Price, boxed and shipped.....\$ 45 00
With Fountain..... 55 00

Furnished with one set of rollers cast, one chase and one wrench.

PRICE OF EXTRAS.

Roller Mould....	\$2 50	Chase.....	\$1 00
" Stocks, each	60	Spider Chase.....	1 25
" Casting, each	50	Hand Roller.....	1 00

BABCOCK CYLINDER PRESSES.

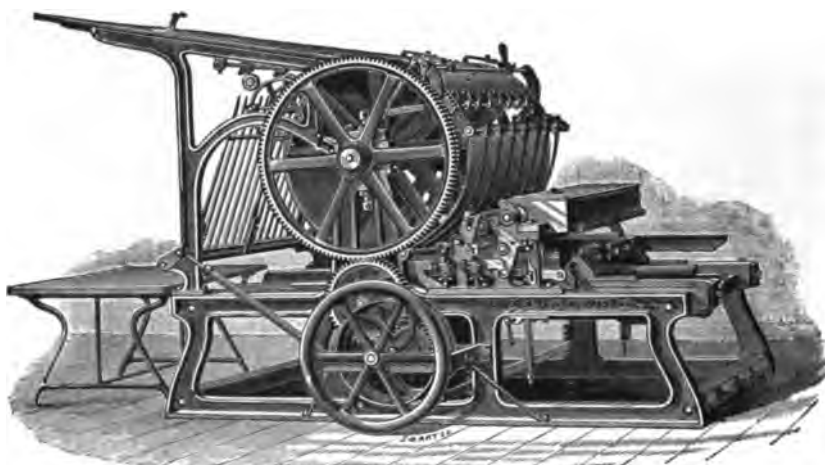

THE BABCOCK PATENT AIR-SPRING COUNTRY PRESS.

The best newspaper and job cylinder press in the market for the price. Size of bed 33x46 inches; will work a 6-column quarto newspaper without "cramping." It is simple, strong, and in every way splendidly constructed. Every machine is run and tested at the works before being boxed. Price includes accurately adjustable feed guides, hinged feed table, two sets roller stocks, roller moulds, wrenches, blanket, boxing, and shipping at New London, Conn.

Price, complete.....\$1,100 00
 Steam Fixtures, extra..... 50 00

Freight from factory to be added.

The accompanying cut is from a photo of the Babcock Country Press. This superb Air-Spring Press is fast making its way into favor with printers who want a fine machine at a reasonable price. It is a thoroughly built press, combining all the latest improvements for fast and good work, together with beauty in design and solidity in all its parts. With its other qualifications it is capable of a high rate of speed; has perfect register, fine distribution, runs easily and almost noiselessly. It is adapted to all kinds of work, having heavy foundation, air-springs and vibrators on form rollers. The rollers pass over the entire form.

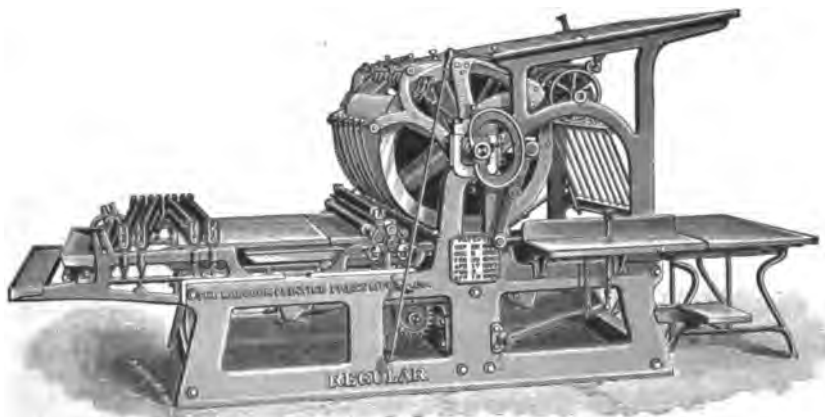

THE BABCOCK "REGULAR" DRUM CYLINDER TYPOGRAPHIC PRESS—TAPELESS DELIVERY.

Back, screw and table distribution. Two and four rollers. This press is manufactured in same sizes as the "Standard," the only difference in mechanism being in the distribution. Prices on application.

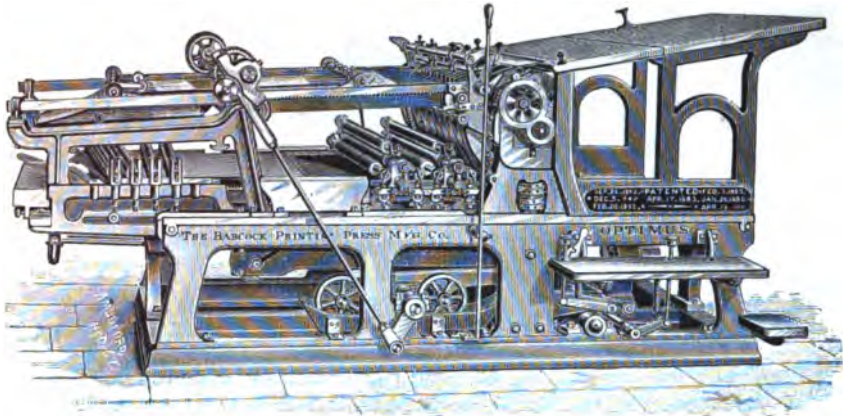
BABCOCK CYLINDER PRESSES.**BABCOCK "OPTIMUS" FRONT DELIVERY TWO-REVOLUTION PRESS.**

Delivers printed side up. No smutting or off-set. Perfect register, distribution and impression. This is the finest press made. All sizes in both two and four rollers. Prices on application.

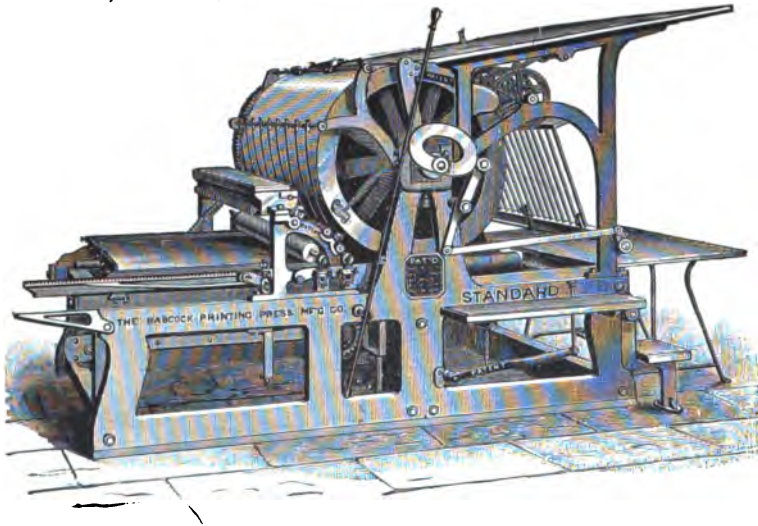
**BABCOCK "STANDARD" AIR-SPRING PRESS.**

These presses are built from new designs, combining strength and durability with increased capacity for speed, and embody several new and very important improvements; among them the following: Noiseless gripper motion, with perfect register. Air valves for removing the spring when desired, and invariably restoring it when the press is started. The shield, which effectually protects the piston and cylinder from paper, tapes, etc., that might fall upon them and produce injury. The piston can be adjusted to the size of the air-cylinder, so that the wear of either can be easily compensated. This easy, positive and perfect adjustment prevents leaks and vacuums and secures evenness of wear in the air-springs. The roller-bearing has the following advantages: Any single roller may be removed without disturbing the others. All the rollers may be removed and replaced without altering their "set." When desired, the form rollers may be released from contact with the distributor and type, without removing the rollers from their bearings or changing their "set." The ink fountain is set very high, allowing easy access to the forms, and furnishes much better distribution than the old style. These presses have also the patent positive slide motion and patent back-up mechanism, and are the equal, and in many respects the superior of any first-class presses in the market. They also have tapeless delivery. These improvements will commend themselves to the approval of printers. Made in all sizes. Prices on application.

THE CRANSTON CYLINDER PRESS.

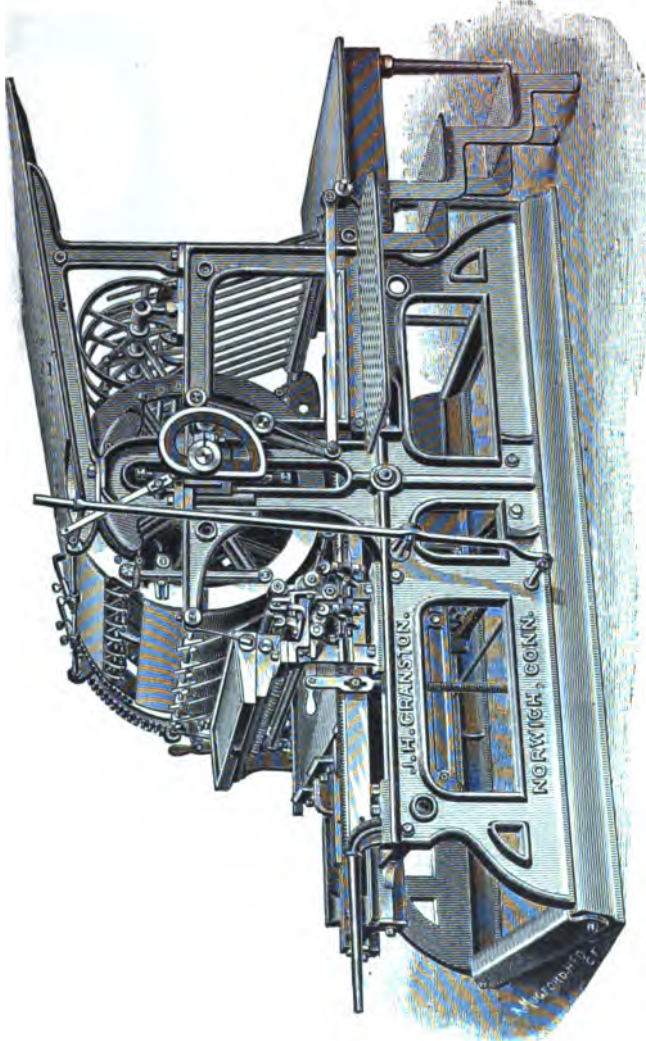

Above cut shows Cranston's improved two-roller newspaper press, with rack and pinion distribution, air springs and tapeless delivery. It has all modern improvements and is built for high speed.

- No. 3, 32x46 inches, weight 9,000 lbs.....\$1500 00
- No. 3½, 33x48 " " 9,500 " 1600 00

Freight from factory to be added.

The Cranston is built in all sizes and styles, two and four rollers. Full information, prices, etc., on application.

THE PALMYRA CYLINDER PRESS.

(For cut of press see page 36.)

This is a rapid, easy running, noiseless, convenient and strong machine, capable of doing first-class work. They register perfectly. These presses are provided with an impression trip which enables the feeder to instantly suspend the impression. It is provided with steel bed shoes, tracks and track rollers, and all gears are cut. The ink table and distributing rollers can be readily moved aside, giving access to the bed on three sides. The facilities for making ready, both as to form and cylinder, are unequalled. The flow of ink from the fountain can be perfectly controlled. Two form rollers, fountain vibrating roller, two composition distributors, and two metallic changers secure perfect distribution. Roller moulds, wrenches and blankets furnished without extra charge.

NO.	SIZE OF BED BETWEEN BEARERS.	SIZE OF FORM.	PRICE.
3	29x43 inches,	24x39 inches,	\$ 700 00
4	32x46 " "	27x42 " "	800 00

Freight from factory to be added.

THE PALMYRA CYLINDER PRESS.

(For prices, etc., see page 35.)

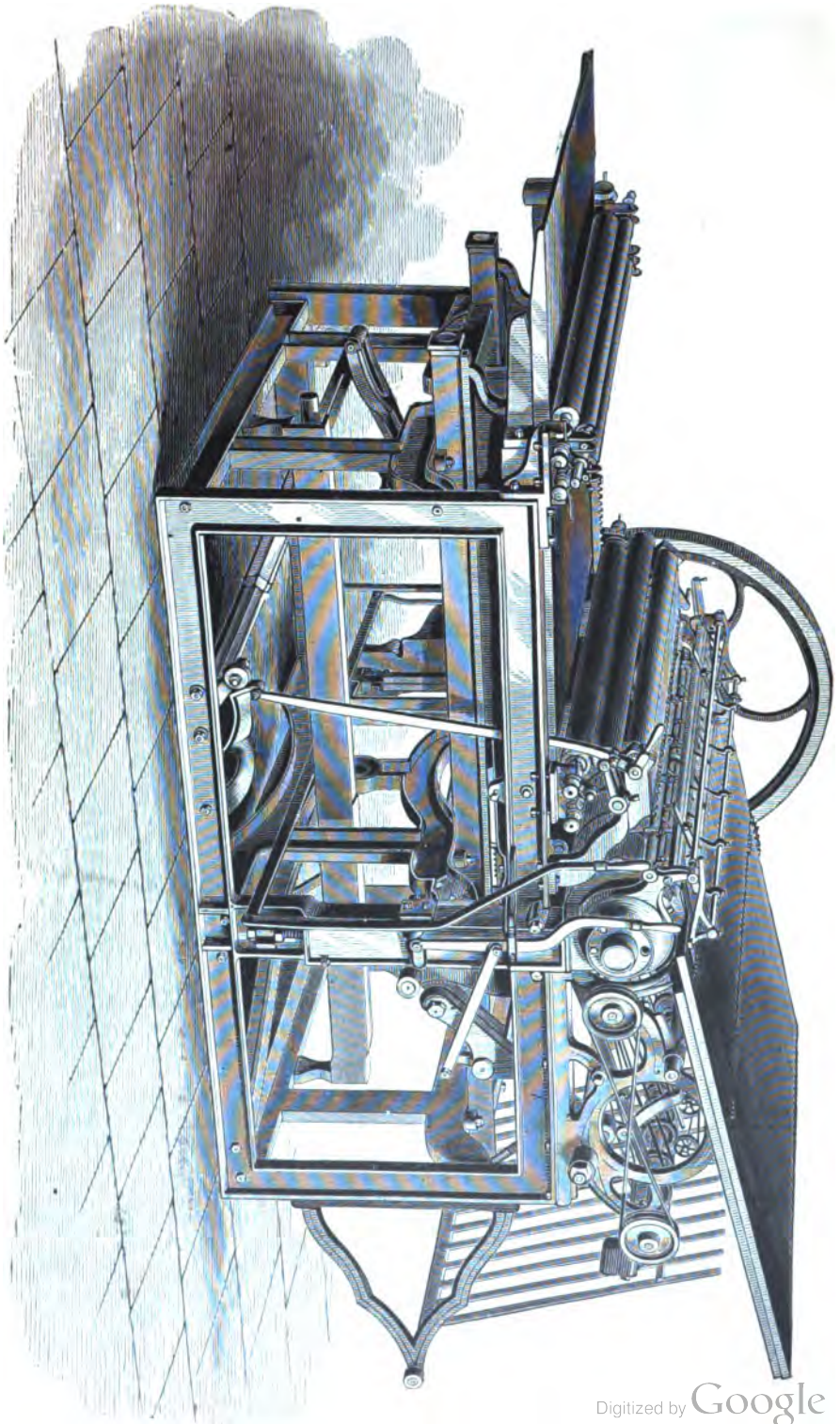

OVERHEAD FIXTURES.

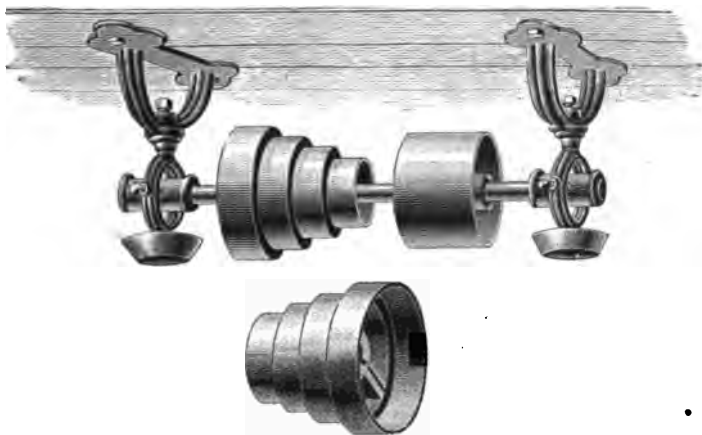

Consist of counter shaft, two self-adjusting hangers with oil cups, two cone pulleys and driving pulley.

For Eighth ¹ Medium, 3 speed cone.....	\$ 20 00
" Eighth Medium, 4 " "	22 50
" Quarter Medium, 3 " "	22 50
" Quarter Medium, 4 " "	25 00
" Half Medium, 3 " "	27 50
" Half Medium, 4 " "	30 00

When ordering over-head fixtures, give exact diameter of main shaft; also number of revolutions per minute.

WASHINGTON HAND PRESS.

PRICES IN SAN FRANCISCO.

7-column, platen 23x35, bed 26½x39.....	\$250 00
8- " " 25x39, " 28½x42	270 00
9- " " 27x43, " 31½x47½.....	300 00

Boxing and Drayage, \$10 00.

Blankets, \$4 00 and \$5 00.

Two pair of points, one wrench and one extra frisket go with each press.

INKING APPARATUS.

Includes 2 cylinders, roller handle and 2 roller cores, complete—

For 7-column press.....	\$22 50
" 8- " "	25 00
" 9- " "	27 50



ARMY PRESS.

This press resembles the modern common Hand Press in having ways, bed, tympan and frisket. In place of a platen and levers, it has a cylinder, by the rotation of which the bed is moved and the impression given at each motion back and forth. The tympan is covered with the best gum cloth. The frisket is covered with paper, same as other hand presses. The form is luted by hand. The impression is adjusted by screws under the bearings of the cylinder. The sheets are worked folded and turned, taking four impressions to complete each paper. 200 to 300 impressions per hour can be worked, and do good newspaper work.

PRICES.

6-column folio, 14 x21 inches....	\$70 00
7- " " 16½x22½ "	90 00





PROOF PRESS.

These are thoroughly constructed and are strong and substantial, with no part to regulate or get out of order; the iron roller, large and heavy, is neatly covered with a felt blanket; angle irons, attached to each end of the frame door, act as brackets when it is opened and as a catch when closed; the frame is of iron, and the closet, very handy for roller, ink and paper, is of walnut.

PRICES IN S. F.

- No. 1, with iron frame, bed 10x31 in....\$ 32
- No. 1, without frame, " 10x31 " ... 23
- No. 2, with iron frame, " 16x31 " ... 44
- No. 2, without frame, " 16x31 " ... 32

Each furnished with extra large and heavy roller neatly covered with best felt blanket, frame of iron, with walnut closet.

ECONOMIC PROOF PRESS.

The Economic Proof Press has at last filled the long-felt want of a cheap and efficient device for taking single and double galley proofs in a printing office. It differs from the more expensive articles in this nature only in the matter of being bottomless—any level surface of stone, metal, glass or wood answers for a rest. The machine consists of two solid iron tracks, connected at the ends by rods of sufficient height to allow the free passage of a galley of type beneath them, and a 21-lb felt-covered cylinder that is operated in precisely the same manner as those of the more expensive proof presses. The full length of track is 34 inches; entire weight of machinery, not exceeding 35 pounds, rendering it easily portable.



Price.....\$ 14 00

PRESS BOARDS.

- 23x30 in.....\$ 0 50
- 26x36 in..... 75
- 31x46 in.....\$ 1 00
- 35x52 in..... 1 25

QUOINS.

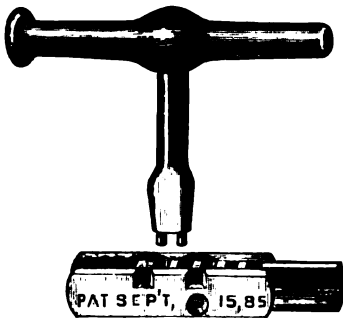

KEYSTONE.

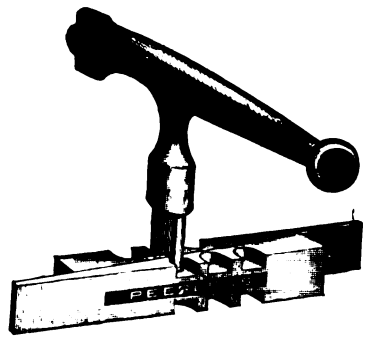

PEERLESS.

Safe, simple, sensible Lock-ups, quick, quiet and quadratic.

PRICES:

- No. 1, per dozen.....\$ 2 50
- No. 2, " 3 00
- Keys, each 50

WOOD QUOINS.

- Hickory, per 100.....\$ 0 60
- Boxwood " 75

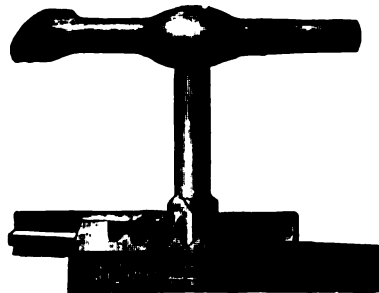

HEMPEL.

HICKOCK RULING MACHINE.

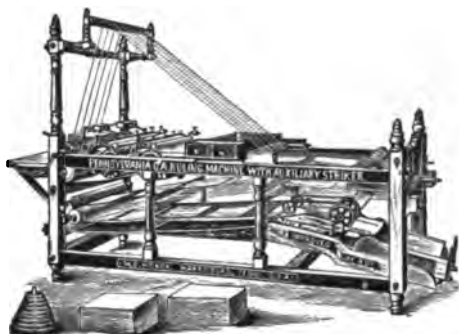

Address us for circulars and prices.

JOB PRESS ROLLERS.



CAST TO ORDER.

	Core.	Casting.	Complete.		Core.	Casting.	Complete.
Eighth medium.....	\$0 75	\$0 50	\$1 25	Half medium.....	\$1 00	\$1 00	\$2 00
Quarter "	85	75	1 60	" super-royal..	1 15	1 25	2 40

HAND ROLLERS.



SIZES AND PRICES.

Length.	Diam.	Frame and Core.	Casting.	Complete.
3-in.	1 1/4	\$0 50	\$0 30	\$0 80
4-in.	1 1/2	65	30	95
5-in.	1 3/4	75	35	1 10
6-in.	1 3/4	90	35	1 25
8-in.	1 3/4	1 00	50	1 50

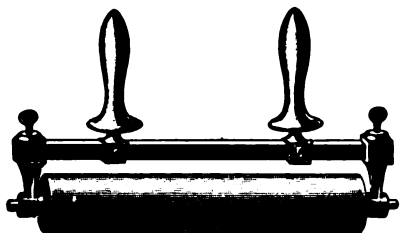

18-in.	3 1/2	2 75	1 80	4 55
--------	-------	------	------	------

HAND PRESS ROLLERS.

Length.	Core.	Casting.	Complete.
36-in.	\$1 20	\$2 75	\$3 95
40-in.	1 40	3 25	4 65
44-in.	1 60	3 75	5 35

ROLLER MOULDS.

3 1/2 inches diameter, per running inch	\$0 40
For eighth medium press.....	3 00
" " large.....	3 50
" quarto " ".....	4 00
" " large.....	4 50
" half " ".....	5 00
" " " ".....	5 50

PROOF ROLLERS.

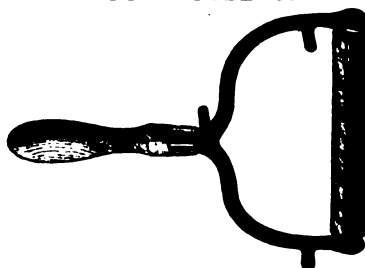

Length.	Diam.	Frame and Core.	Casting.	Complete.
6-in.	3 1/2-in.	\$1 20	\$0 65	\$1 85
8-in.	3 1/2-in.	1 50	80	2 30
10-in.	3 1/2-in.	1 75	1 00	2 75

CYLINDER PRESS ROLLERS.

CAST TO ORDER.

Per lb.....	\$0 35
-------------	--------

ROLLER COMPOSITION.



Fidelity, per lb..... Digitized by Google \$0 30

ROLLER BEARERS FOR PLATEN PRESSES.



The Bearers only take up about 1/4 inch inside each side of chase, the bearing surface overlapping the chase.

PRICE PER PAIR.

For 6x 9 press...\$0 35	For 10x15 press.\$0 50
" 7x11 " " 40	" 12x18 " 70
" 8x12 " " 45	" 13x19 " 75

SHOOTING STICKS.



Steel.....	\$0 75
Malleable Iron.....	50

SIDE AND FOOT STICKS.

Iron, beveled, per inch.....	\$0 06
" straight, "	05

SUB-HEADINGS.

Electrotyped, any pattern.....	\$0 55
--------------------------------	--------

SCISSORS AND SHEARS.

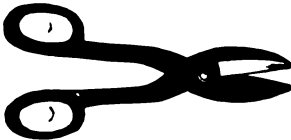

Snips.....	\$1 50
Scissors.....	75

STEREOTYPING PAPER.

PAPIER MACHE.

Per ream.....	\$15 00
Per quire.....	1 00

FACE PAPER.

White, per ream.....	\$4 50
" per quire.....	30
Cream, per ream.....	5 25
" per quire.....	40

STEREOTYPING BACKING COMPOUND.

Price, per lb.....\$0 20

TAPES.

FOR POWER PRESSES.

1/2-inch wide, per roll.....	\$0 85
3/4- " " "	1 35
1- " " "	1 65
1 1/2- " " "	1 75

TAKE SLUGS.

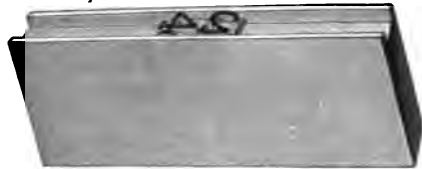

THE ST. JOHN TAKE SLUG.

The above cut represents a useful improvement in "Take Slugs," made of brass, solid and substantial; they have bearers above and below the figures, which protect them from injury, and give a line to measure from. The hole in the center is the exact size of the type used, and when the figures become useless they can be replaced at a very trifling cost. To the foreman or compositor in the newspaper office the slug speaks for itself more eloquently than words can.

Cut to any measure.....25 cents each

4

BRASS INDENTED TAKE SLUGS.

This slug is made of solid brass, and is almost indestructible. The figures are plainly indented in the face of the slug, and the line to measure from is unmistakable. They are cheaper than the ordinary electrotyped slug.

Cut to any measure.....20 cents each

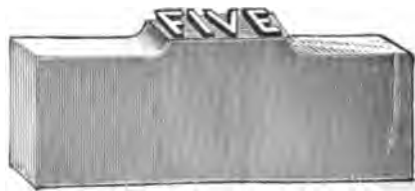

ELECTROTYPED TAKE SLUG.

Made from any figure or letter selected, not over Great Primer Body, at 20 cents each.

TYPE MEASURES.



Boxwood, 9-inch.....	\$1 50
" 12- "	3 00

Golding's, 12-inch\$0 15

WOOD RULE.

Per yard.....	\$0 12
---------------	--------

WOOD TYPE AND BORDERS.

Hamilton's and Page's at their list prices.

EXPLANATION OF THE ALIQUOT SYSTEM OF BODIES,

ON WHICH ALL TYPE AND RULE IN THIS BOOK IS MADE.

1-Point

POINT. This is the unit of all measurement in the Aliquot System of Bodies. It is exactly one-seventy-second of an inch, and one-twelfth of Pica.

1½-Point

GERMAN. This body is ½ of a Pica, and ¼ of Nonpareil. It is familiarly known as "Eight-to-Pica."

2-Point

SAXON is ½ of Pica, and ¼ of Nonpareil. It is the most useful of the lead and rule bodies. Four Saxons make one Brevier; five a Long Primer; six a Pica.

2½-Point

NORSE is ¼ of Long Primer.

3-Point

BRILLIANT is ¼ of Pica, and ½ of Nonpareil.

3½-Point

RUBY is ½ of Minion, and ¼ of English.

4-Point

EXCELSIOR is ½ of Brevier and ⅓ of Pica.

4½-Point

DIAMOND is ½ of Bourgeois, and ¼ of Great Primer.

5-Point

PEARL is ½ of Long Primer, and ¼ of Paragon.

5½-Point

AGATE is ½ of Small Pica.

6-Point

NONPAREIL is ½ of Pica, and ¼ of Great Primer. It is exactly one-twelfth of an inch.

7-Point

MINION is ½ of English.

8-Point

BREVIER is ½ of Columbian, and ⅔ of Pica.

9-Point

BOURGEOIS is ½ of Great Primer, and ⅔ of Pica. It is exactly ⅓ of an inch.

10-Point

LONG PRIMER is ½ of Paragon.

11-Point

SMALL PICA is ½ of Double-Small Pica.

12-Point

PICA is exactly ⅓ of an inch. This body is the printer's standard for measurement.

14-Point

ENGLISH is 2-lines Minion; a Nonpareil and a Brevier. Pica and a Saxon lead justify with it.

16-Point

COLUMBIAN is 2-lines Brevier; a Nonpareil and a Long Primer; etc.

18-Point

GREAT PRIMER is 3-lines Nonpareil; 2-lines Bourgeois; a Brevier and a Long Primer, etc. A Great Primer 3-em space is the same as a Nonpareil 3-em quad. 18-Point is exactly ¼ of an inch.

20-Point

PARAGON is 2-lines Long Primer; a Brevier and a Pica; Nonpareil and English; etc.

22-Point

DOUBLE SMALL PICA is 2-lines Small Pica; a Long Primer and a Pica; etc.

24-Point

DOUBLE PICA is 2-lines Pica; 3-lines Brevier; etc. It is ½ of an inch.

Each size is a factor, and justification of one body with another is therefore certain and simple. The Table of Sizes shows this fractional system so perfectly that it is not thought necessary to carry the sizes any higher than 24-Point, for further illustration. It is easy enough to understand that 28-Point is Double English, 30-Point is 5-line Nonpareil, 32-Point is Double Columbian, 36-Point is Double Great Primer, 40-Point is Double Paragon, 42-Point is 7-line Nonpareil, etc.

Fractional type bodies were first introduced into France, by M. Didot. The graduation was made by tenths, their 10-Point body, *Corpus*, being the standard. The French bodies, however, not agreeing with the American inch, Mr. N. C. Hawks, of San Francisco, proposed the above plan (of graduation by twelfths, from a Pica that should gauge exactly ⅓ of an inch,) to his firm, who adopted it in 1876. Other foundries followed, one by one, until nearly all are in harmony with this Aliquot System.

NEW BRASS RULES.

IN STRIPS OF TWO FEET, WITH PRICE PER FOOT.

DIAGRAM SERIES.

313 $\frac{3}{4}$	American	.06
313 $\frac{1}{2}$	German	.08
314	Saxon	.10
314 $\frac{1}{2}$	Norse	.12
315	Brilliant	.15
315 $\frac{1}{4}$	Excelsior	.20
315 $\frac{1}{2}$	Pearl	.25
316	Nonpareil	.30
317	Brevier	.40
318	Long Primer	.50
318 $\frac{1}{2}$	Pica	.60

SERIES 1.

220	American	.06
221	German	.08
222	Saxon	.10
223	Norse	.12
224	Brilliant	.15
225	Excelsior	.20
226	Pearl	.25
227	Nonpareil	.30
228	Minion	.35
229	Brevier	.40
230	Bourgeois	.45
231	Long Primer	.50

SERIES 2.

250	Saxon	.10
251	Norse	.12
252	Brilliant	.15
253	Excelsior	.20
254	Pearl	.25
255	Nonpareil	.30
256	Minion	.35
257	Brevier	.40
258	Bourgeois	.45
259	Long Primer	.50

SERIES 5.

232	Brilliant	.15
233	Brilliant	.15
234	Excelsior	.20
235	Pearl	.25
236	Nonpareil	.30
237	Minion	.35
238	Brevier	.40
239	Bourgeois	.45
240	Long Primer	.50

SERIES 8.

241	Norse	.12
242	Brilliant	.15
243	Excelsior	.20
244	Pearl	.25
245	Nonpareil	.30
246	Minion	.35
247	Brevier	.40
248	Bourgeois	.45
249	Long Primer	.50

WAVE SERIES.

351	German	.10
352	Saxon	.12
356	German	.12
357	Norse	.12
358	Norse	.12

LEADER SERIES.

319	Saxon	.10
320	Saxon	.10
321	German	.10
322	German	.10

NEW BRASS RULES.

IN STRIPS OF TWO FEET, WITH PRICE PER FOOT.

SERIES 20.

550	German	.12
551	Brilliant	.18
552	Excelsior	.22
553	Nonpareil	.32
553½	Bourgeois	.42
554	Pica	.65

SERIES 21.

594	Saxon	.12
596	Brilliant	.18
598	Excelsior	.22
600	Pearl	.27
564	Nonpareil	.32
602	Brevier	.42
566	Pica	.65

SERIES 23.

610	Saxon	.12
612	Brilliant	.18
614	Excelsior	.22
616	Pearl	.27
618	Nonpareil	.32
620	Brevier	.42

SERIES 24.

648	Saxon	.12
650	Brilliant	.18
652	Excelsior	.22
654	Pearl	.27
656	Nonpareil	.32
657	Bourgeois	.42
658	Bourgeois	.42
660	Pica	.65

SERIES 22.

746	Saxon	.12
747	Brilliant	.18
748	Excelsior	.22
749	Pearl	.27
750	Nonpareil	.32
752	Pica	.65

MISCELLANEOUS.

756	Pica	.40
757	3-line Nonpareil	.60
808	3-line Nonpareil	.60
809	2-line Pica	.80

788 Pica .70



789 2-line Pica 1.40



588 Pica .70



588½ 2-line Brevier 1.00



815 Pica .60



817 2-line Pica 1.40



769 Nonpareil .50



770 Bourgeois .55



771 Pica .65



772 2-line Brevier .80



773 3-line Nonpareil .95



774 2-line Pica 1.25



837 Nonpareil .30



838 Pica .60



561 Pica .70



841 Pica .60



Newspaper Rules.

Head Rules.

No. 253.	Excelsior body.	40 cts. each.
No. 234.	Excelsior body.	40 cts. each.
No. 243.	Excelsior body.	40 cts. each.
No. 254.	Pearl body.	50 cts. each.
No. 235.	Pearl body.	50 cts. each.
No. 244.	Pearl body.	50 cts. each.
No. 255.	Nonparell body.	60 cts. each.
No. 236.	Nonparell body.	60 cts. each.
No. 245.	Nonparell body.	60 cts. each.
No. 256.	Minion body.	70 cts. each.
No. 237.	Minion body.	70 cts. each.
No. 246.	Minion body.	70 cts. each.
No. 257.	Brevier body.	80 cts. each.
No. 238.	Brevier body.	80 cts. each.
No. 247.	Brevier body.	80 cts. each.

Standard Length.

HEAD RULES.			COLUMN RULES.		
4-column, Folio or Quarto,	-	8 $\frac{7}{8}$ inches.	4-column Folio or Quarto,	13 $\frac{7}{8}$ inches face.	
5- " " "	-	11 $\frac{1}{8}$ "	5- " " "	18 " "	
6- " " "	-	13 $\frac{3}{8}$ "	6- " " "	19 $\frac{3}{4}$ " "	
7- " " "	-	15 $\frac{3}{4}$ "	7- " " "	21 $\frac{3}{4}$ " "	
8- " " "	-	18 "	8- " " "	23 $\frac{3}{4}$ " "	
9- " " "	-	20 $\frac{1}{4}$ "	9- " " "	25 $\frac{3}{4}$ " "	

PRICES OF COLUMN RULES.

Nonparell body: 12 inches or less,	35 cts. each;	24 inches or less,	65 cts.;	28 inches or less,	75 cts.
Minion " " "	40 " "	" " 70 " "	" " "	" " 85 "	
Brevier " " "	45 " "	" " 75 " "	" " "	" " 95 "	

CROSS RULES.

Single, or Advertising, 5 cts.

Parallel Cross, 8 cts.

Double Cross, 8 cts.

Wave Cross, 6 cts.

DASH RULES.

Single Dash Rule, $\frac{1}{2}$ inch face, 8 cts.

Single Dash Rule, 1 inch face, 8 cts.

Parallel Dash Rule, 1 inch face, 9 cts.

Double Dash Rule, 1 inch face, 9 cts.

Cross and Dash Rules can be made from any faces selected from the pages of Brass Rules. When ordering Cross Rules, give the No. of Rule, and width of column. For Dash Rules, state No. of Rule, measure of column and length of face.

LABOR-SAVING BRASS RULE.

The Rules are accurately cut to PICA ems. All Fonts contain an assortment of Mitres. Other sizes and styles cut to order.

SINGLE. No. 222.
 6 to Pica Body.
 —
 2¾ lbs. average weight
 of Fonts.
 Price, \$1.75 per lb.

DOTTED. No. 319.
 6 to Pica Body.
 —
 2¼ lbs. average weight
 of Fonts.
 Price, \$1.75 per lb.

Parallel. No. 253.
 3 to Pica Body.
 —
 Average weight of
 Font, 5¼ lbs.
 Price, \$1.60 per lb.

Double. No. 234.
 3 to Pica Body.
 —
 Average weight of
 Font, 5¼ lbs.
 Price, \$1.75 per lb.

Double. No. 235.
 Pearl Body.
 —
 Average weight of
 Fonts, 6 lbs.
 Price, \$1.60 per lb.

Double. No. 236.
 2 to Pica Body.
 —
 Average weight of
 Fonts, 8 lbs.
 Price, 1.50 per lb.

BRACES.

No. 62, 30 cts.	
No. 61, 30 cts.	
No. 60, 30 cts.	
No. 59, 30 cts.	
No. 58, 30 cts.	
No. 57, 25 cts.	No. 31, 12 cts.
No. 56, 25 cts.	No. 32, 12 cts.
No. 55, 25 cts.	No. 33, 12 cts.
No. 54, 25 cts.	No. 34, 12 cts.
No. 53, 25 cts.	No. 35, 12 cts.
No. 51, 18 cts.	No. 36, 12 cts.
No. 50, 18 cts.	No. 37, 12 cts.
No. 49, 18 cts.	No. 38, 12 cts.
No. 48, 18 cts.	No. 39, 12 cts.
No. 47, 15 cts.	No. 40, 12 cts.
No. 46, 15 cts.	No. 41, 15 cts.
No. 45, 15 cts.	No. 42, 15 cts.
No. 44, 15 cts.	No. 43, 15 cts.

Complete Set, \$5.00.

BRASS CIRCLES.

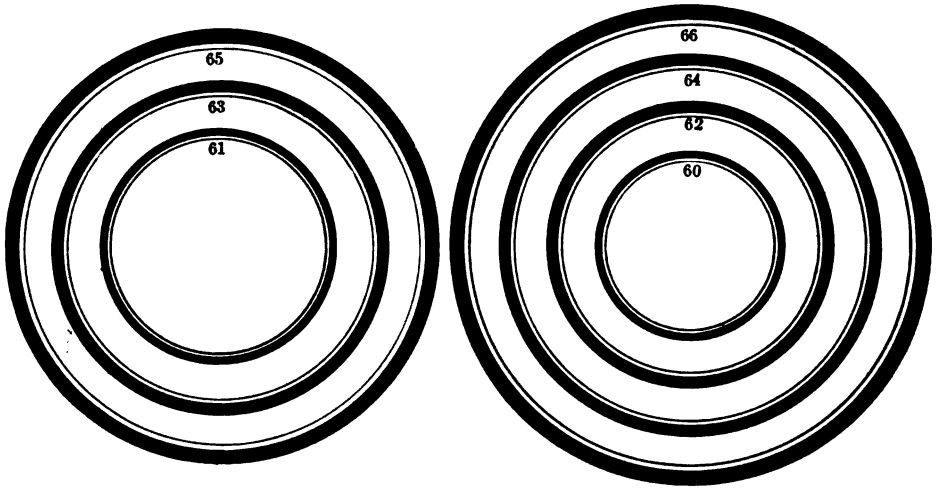

CIRCLES.—Nos. 60 and 61, 60 cents each; Nos. 62 to 65, inclusive, 75 cents each; No. 66, \$1.00.

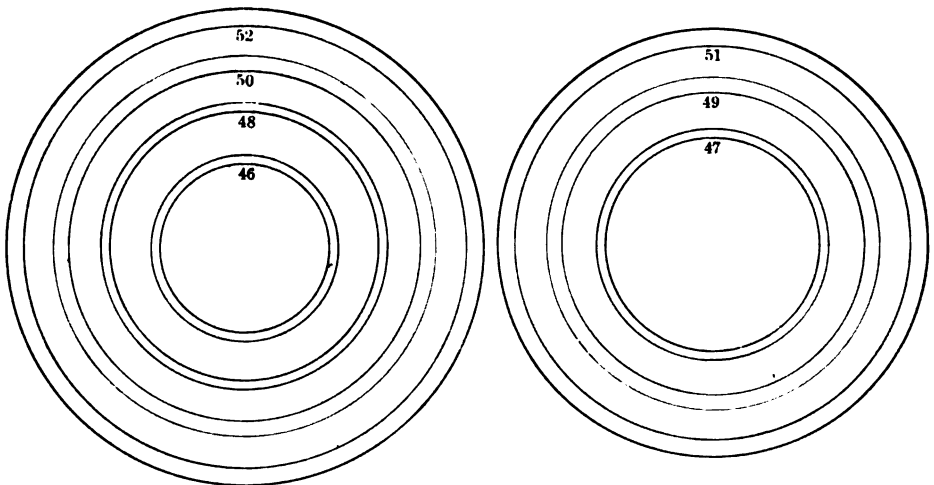

CIRCLES.—Nos. 46 and 47, 60 cents each; Nos. 48 to 51, inclusive, 75 cents each; No. 52, \$1.00.

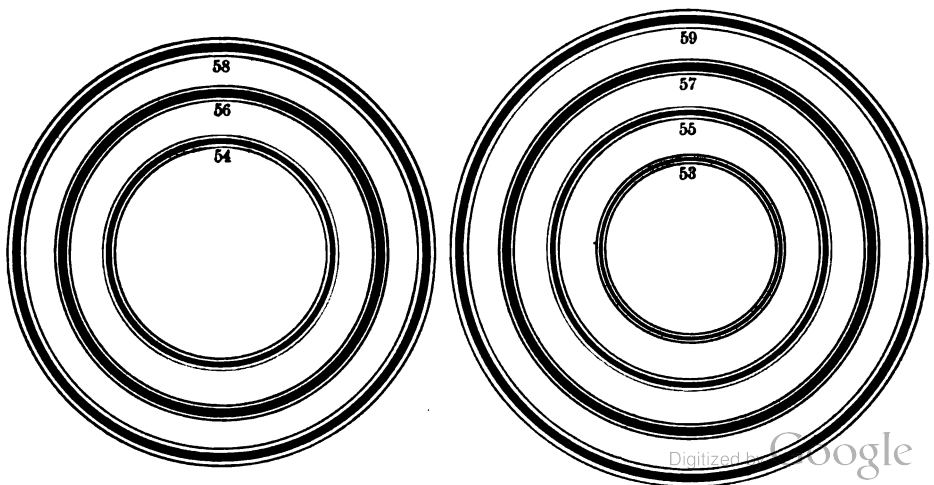

CIRCLES.—Nos. 53 and 54, 60 cents each; Nos. 55 to 58, inclusive, 75 cents each; No. 59, \$1.00.

BRASS CIRCLES AND OVALS.

CIRCLES.—Nos. 14 to 19, inclusive, 60 cents each; Nos. 20 to 27, inclusive, 75 cents each; No. 28, 90 cents.
OVALS.—Nos. 13 to 19, inclusive, 90 cents each; Nos. 20 to 27, inclusive, \$1.00.

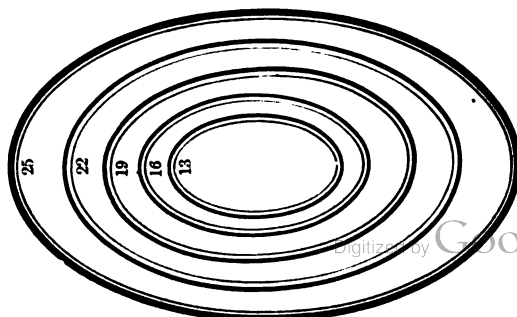
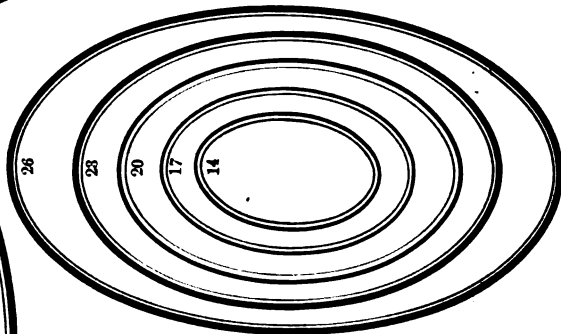
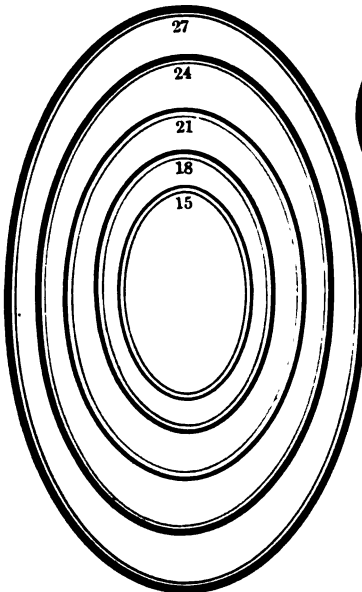
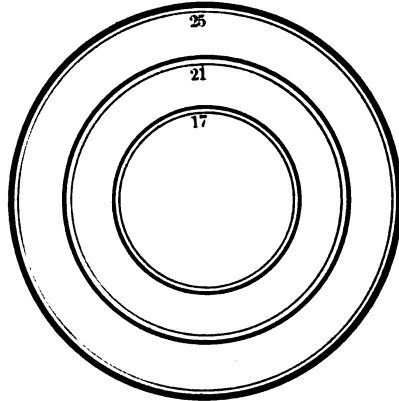
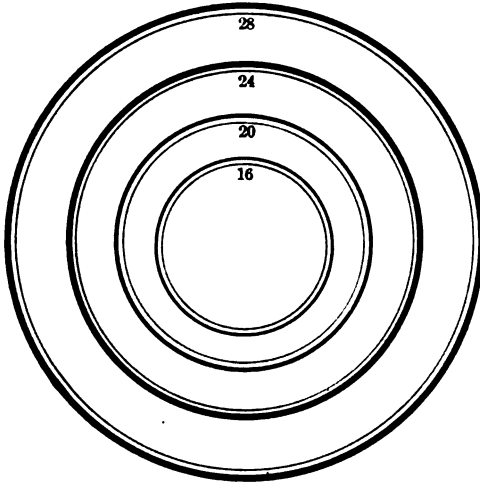
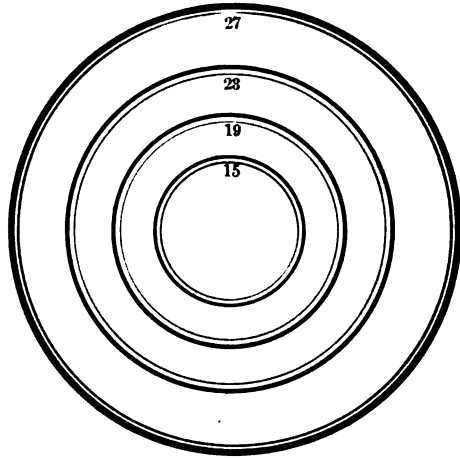
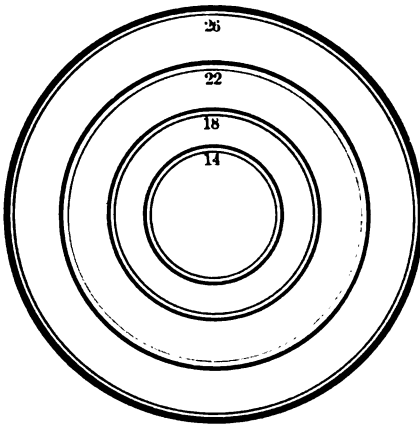

Brass Dashes.

Price, 10 cents each.

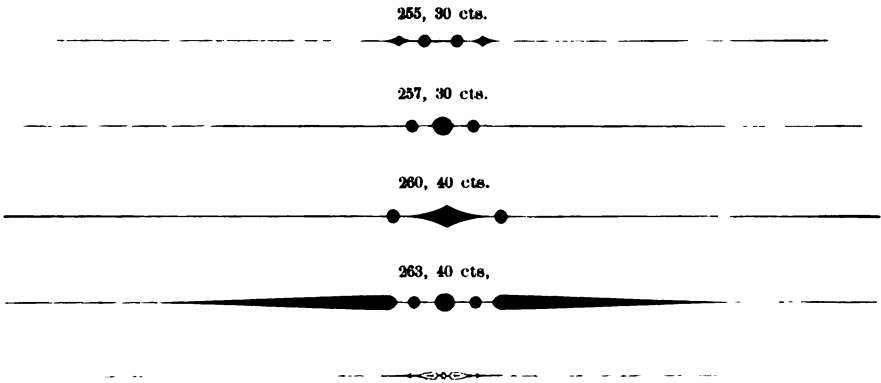
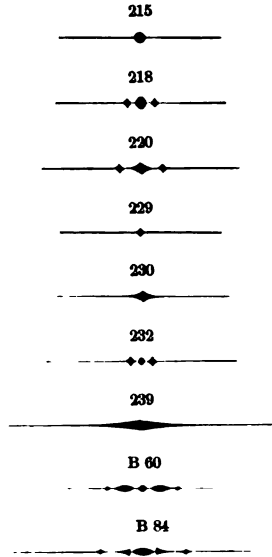
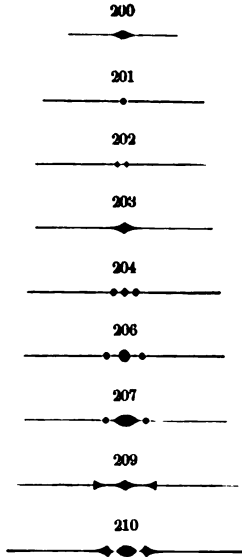

ORNAMENTAL DASHES.

Price, 25 cents each.

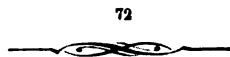
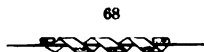

Digitized by

Newspaper Headings.

Headings electrotyped from any style of letter shown. Average Price, \$3.00.

48-POINT COMPRESSED.

Pescadero Times

48-POINT COMPRESSED CAPS.

SONOMA FLAG

60-POINT COMPRESSED.

Bolinas Eagle

60-POINT COMPRESSED CAPS.

OLEMA BEE

48-POINT AND 40-POINT TWO-LINE NO. 5.

BODIE MAIL

48-POINT TWO-LINE NO. 5.

IONE ITEM

60-POINT TWO-LINE NO. 5.

VISITOR

Newspaper Headings.

48-POINT AND 60-POINT TWO-LINE NO. 5.

NEW ERA

96-POINT AND 72-POINT TWO-LINE NO. 5.

GUARD

48-POINT LIGHTFACE CELTIC.

Adin News

60-POINT METROPOLITAN.

IMPRINT

60-POINT OLD STYLE CONDENSED NO. 2.

Kangaroo Appeal

72-POINT OLD STYLE CONDENSED NO. 2.

The Free Press

Newspaper Headings.

42-POINT AND 48-POINT WAYSIDE.

MONO INDEX

60-POINT LIGHTFACE RUNIC.

Salem Argus

48-POINT AND 60-POINT BISQUE.

COLUSA GLOBE

60-POINT AND 72-POINT BISQUE.

DIXON POST

72-POINT OLD STYLE.

New Age

48-POINT CHALLENGE.

Lodi Umpire

60-POINT BLACK_OPEN NO. 1.

Daily Call

Newspaper Headings.

60-POINT ANGLC-SAXON.

Our Typograph

60-POINT BLACK.

Vallejo Eye

72-POINT FRANKLIN TEXT SHADED.

San Luis Owl

84-POINT MODERN BLACK SHADED.

Vintal Post

96-POINT FRANKLIN TEXT SHADED NO. 2.

Rio Herald

84-POINT MODERN TEXT OPEN.

Yonre Voice

PLAIN FACES.

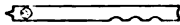

6-POINT ROMAN No. 10 (Nonpareil).

PRINTING is the art of producing impressions, from characters or figures, on paper or any other substance. There are several distinct branches of this important art—as the printing of books with movable types, the printing of engraved copper and steel plates, and the taking of impressions from stone, called lithographing. We have now to describe the printing of books or sheets with movable types, generally called letter-press printing, and which may undoubtedly be esteemed the greatest of all human inventions. The art of printing is of comparatively modern origin, only four hundred years having elapsed since the first book was issued from the press; yet we have proofs that the principles upon which it was ultimately developed existed among the ancient Assyrian nations. Entire and undecayed bricks of the famed city and tower of Babylon have been found stamped with various symbolic figures and hieroglyphic characters. In this, however, as in any similar relic of antiquity, the object which stamped the figures was in one block or piece, and could therefore be employed only for one distinct subject. This, though a kind of printing, was totally useless for the propagation of literature, on account both of its expensiveness and tediousness. The Chinese are the only existing people who still pursue this rude mode of printing by stamping paper with blocks of wood. The work which they intend to be printed is, in the first place, carefully written upon sheets of thin transparent paper; each of these sheets is glued, with the face downwards, upon a thin tablet of hard wood; and the engraver then, with proper instruments, cuts away the wood in all those parts on which nothing is traced; thus leaving the transcribed characters in relief, and ready for printing. In this way as many tablets are necessary as there are written pages. No press is used; but when the ink is laid on and the paper carefully placed above it, a brush is passed over with the proper degree of pressure. A similar kind of



7-POINT ROMAN No. 10 (Minion).

PRINTING is the art of producing impressions, from characters or figures, on paper or any other substance. There are several distinct branches of this important art—as the printing of books with movable types, the printing of engraved copper and steel plates, and the taking of impressions from stone, called lithographing. We have now to describe the printing of books or sheets with movable types, generally called letter-press printing, and which may undoubtedly be esteemed the greatest of all human inventions. The art of printing is of comparatively modern origin, only four hundred years having elapsed since the first book was issued from the press; yet we have proofs that the principles upon which it was ultimately developed existed among the ancient Assyrian nations. Entire and undecayed bricks of the famed city and tower of Babylon have been found stamped with various symbolic figures and hieroglyphic characters. In this, however, as in any similar relic of antiquity, the object which stamped the figures was in one block or piece, and could therefore be employed only for one distinct subject. This, though a kind of printing, was totally useless for the propagation of literature, on account both of its expensiveness and tediousness. The Chinese are the only existing people who still pursue this rude mode of printing by stamping paper with blocks of wood. The work which they intend to be printed is, in the first place, carefully written upon sheets of thin transparent paper; each of these sheets is glued, with the face downwards, upon a thin tablet of hard wood; and the engraver then, with proper instruments, cuts away the wood in all those parts on which nothing is traced; thus leaving the transcribed characters in relief, and ready for printing. In this way as many tablets are necessary as there are written pages. No press is used; but when the ink

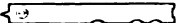

8-POINT ROMAN No. 10 (Brevier).

PRINTING is the art of producing impressions, from characters or figures, on paper or any other substance. There are several distinct branches of this important art—as the printing of books with movable types, the printing of engraved copper and steel plates, and the taking of impressions from stone, called lithographing. We have now to describe the printing of books or sheets with movable types, generally called letter-press printing, and which may undoubtedly be esteemed the greatest of all human inventions. The art of printing is of comparatively modern origin, only four hundred years having elapsed since the first book was issued from the press; yet we have proofs that the principles upon which it was ultimately developed existed among the ancient Assyrian nations. Entire and undecayed bricks of the famed city and tower of Babylon have been found stamped with various symbolic figures and hieroglyphic characters. In this, however, as in any similar relic of antiquity, the object which stamped the figures was in one block or piece, and could therefore be employed only for one distinct subject. This, though a kind of printing, was totally useless for the propagation of literature, on account both of its expensiveness and tediousness. The Chinese are the only existing people who still pursue this rude mode of printing by stamping paper with blocks of wood. The work which they intend to be printed is, in the first place, carefully written upon sheets of thin transparent paper; each of these sheets is glued, with the face downwards, upon a thin tablet of hard wood; and the engraver then, with proper instruments, cuts away the

PLAIN FACES.

(2-nick)

6-POINT ROMAN No. 13 (Nonpareil).

THE successful printer can attribute much of his fame to the persistency with which he endeavors to cater to the tastes and peculiarities of his patrons. To faithfully conform to the eccentricities of a certain class of people is no small task, and requires the exercise of that very essential requisite—patience—a virtue which every printer, if he wishes to occupy an advanced position in the calling, must cultivate. Our first statement, however, needs a little mending; yet the modification does not alter the fact. To make the matter plain, we will cite an example. An impecunious individual is obliged to seek the services of the printer. He wishes 5,000 bills printed, has but little means, and naturally desires the cheapest quality of work. Anything that sets forth his ideas, no matter how badly the rules of good taste are outraged, or how inferior the work, answers his requirements, or at least that is the view he entertains. In this case it would not be policy to strictly adhere to the wishes of a patron, and allow such damaging evidences of a printer's skill (?) to be circulated. Printers early learn the inevitable consequence of inferior workmanship, and only in exceptional cases do they quote prices that are inconsistent with creditable production, and in those cases they are governed more by the financial status of their patrons than by any desire to profit by a poor grade of work. The productions of this character are almost invariably traceable to the amateur, who, having no adequate conception of his calling, builds up a fictitious standard and glories in the result of his unskilled efforts. Thus it is that this one class of labor has an existence; it is stimulated and supported by those short-sighted people who believe that

ABCDEFGHIJKLMN O PQRSTU VWXYZ & Æ

ABCDEFGHIJKLMN O PQRSTU VWXYZ & Æ

abcdefghijklmnopqrstuvwxyzæ \$ £ 1234567890 ¼½¾⅓⅔⅕⅖⅗⅘⅙⅚

Ⓐ @ # \$ % ° ' " &

(3-nick)

7-POINT ROMAN No. 14 (Minion).

It is a remarkable fact that no class of business men have made less progress, morally, intellectually or socially, during the last two centuries, than the Book Publishers. However strange—not to say incredible—it may seem, it is particularly true of the publishers of our own country. At the same time, none need fear that we contemplate anything unduly harsh in the observations we are about to make on the subject. In instituting comparisons between the old and the new, we have to state facts, and examine the bearing which they seem to have on each other. If those facts are not all what they should be, the fault is not ours. We take up "the trade" as a subject the same as we do the antiquities of the Egyptians, the Hindoos or the Chinese; not for the purpose of bestowing praise or passing censure, but to learn from it whatever we can. No doubt in speaking of the Hindoos we say many things that would not be pleasing to the Brahmans should those worthy men happen to see them. Probably they would accuse us of malice, and tell the world that we are thus malignant because they would not allow us to desecrate the Vedas or other sacred books. If our friends, the publishers, are very much like the Brahmans in this respect, we cannot help it; nor can we say that we fear their

ABCDEFGHIJKLMN O PQRSTU VWXYZ & Æ

ABCDEFGHIJKLMN O PQRSTU VWXYZ & Æ \$ £ 1234567890 ¼½¾⅓⅔⅕⅖⅗⅘⅙⅚

abcdefghijklmnopqrstuvwxyzæ

Ⓐ @ # \$ % ° ' " &

(2-nick)

8-POINT ROMAN No. 14 (Brevier).

ASTONISHING it is that people will persist in practicing deceit. It is the most detestable and vicious agency that can be used in human intercourse. Men in all conditions of life, the lowest as well as the highest, despise and abhor it as an adder. You may slander, abuse and beat a man, and he can forgive it; but once make him the dupe of your deceit and in spite of himself he will always treasure up in his heart a secret hatred, vengeance and mistrust of you that is insatiable and incurable. Nothing was ever gained by it, as its results are inevitably fatal. Even though the end be accomplished, it is always followed by an unceasing, never ending dread and fear of discovery which will finally culminate in confession and shame. The world is too sharp-sighted to be kept in the dark, and human nature is too weak and dependent to long withstand the ceaseless pressure of guilt and shame. "Murder" will out, and the old adage has been demonstrated thousands of times. In business, and in society one deceitful action or word, however slight, will irretrievably damage your character and good standing. It is worse than lying, worse than dishonesty, for it is the very essence of both; and the person who practices deceit will not hesitate long before perjury or theft. It stifles ambition, shatters morals, and for these and other reasons *Square Dealing is far preferable.*

ABCDEFGHIJKLMN O PQRSTU VWXYZ & Æ

ABCDEFGHIJKLMN O PQRSTU VWXYZ & Æ

abcdefghijklmnopqrstuvwxyzæ \$ £ 1234567890 ¼½¾⅓⅔⅕⅖⅗⅘⅙⅚

Ⓐ @ # \$ % ° ' " &

PLAIN FACES.

(3-nick)

9-POINT ROMAN No. 13 (Bourgeois).

Several years ago we pointed out in these pages that a knowledge of the laws of color is as important to the printer as a knowledge of the art of drawing. If the latter enables the printer to sketch out his idea of the plan of a job, and also to avoid the anachronisms of design which are so often seen, the former creates a desire to use the most appropriate combination of tints and colors, and to avoid those vulgar, gaudy and displeasing effects which, proceeding from ignorance of the laws of color, inevitably spoil the best jobs wherever they are introduced. The cause of this is, in nearly every instance, sheer ignorance. There are persons who, with no knowledge of this kind, contrive to avoid blunders, and even often achieve good effects. In the same way, there are persons whose conversation is quite unexceptionable, who have never had the advantages of an education, and others who never know the slightest rudiments of syntax. These appear to have a kind of intuitive knowledge of the right words to select ; and printers who, without the



9-POINT ROMAN No. 10 (Bourgeois).

PRINTING is the art of producing impressions, from characters or figures, on paper or any other substance. There are several distinct branches of this important art—as the printing of books with movable types, the printing of copper and steel plates, and the taking of impressions from stone, called lithographing. We have now to describe the printing of books or sheets with movable types, generally called letter-press printing, and which may undoubtedly be esteemed the greatest of all human inventions. The art of printing is of comparatively modern origin, only four hundred years having elapsed since the first book was issued from the press ; yet we have proofs that the principles upon which it was ultimately developed existed among the ancient Assyrian nations. Entire and undecayed bricks of the famed city and tower of Babylon have been found stamped with various symbolic figures and hieroglyphic characters. In this, however, as in any similar relic of antiquity, the object which stamped the figures was in one block or piece, and could therefore be employed only for one distinct subject. This, though a kind of printing, was totally useless for the propagation of literature, on account both of its expensiveness and tediousness. The Chinese are the only existing people who still pursue this rude mode of printing by stamping paper with blocks of wood. The work which they intend to be printed is, in the first place, carefully written upon sheets of thin transparent paper ; each of these sheets is glued with the face downwards upon a thin tablet of hard

(2-nick)

10-POINT ROMAN No. 11 (Long Primer).

The chief interest in the history of Spain is to be found in two great epochs—one, embracing the career of the Moors in that country, and the effect they produced on its national character, and on the civilization of Europe ; the other the discovery and settlement of America by the Spaniards, after the domination of the Moors in the Peninsula had received its death-blow at the hands of Ferdinand and Isabella. The history of the discovery of the New World, which has produced such extraordinary results to mankind, and exceeds in importance all other events in modern times, is known to every reader ; but the fact is not so well known that even so far back as 1788 this style of type was regarded as a standard, even among the most obdurate typographic authority of modern times. Book and newspaper work requires as nice discrimination in the selection of the size and style of types used as that of any other branch of the business, and where it is not exercised the work will be faulty and unfinished, and tend to demoralize the taste of the public, as well as help

PLAIN FACES.

(3-nick)

11-POINT ROMAN No. 7 (Small Pica).

Workmanship of the present day in the line of Printing, as compared with the best product of the art, say 1800, is immeasurably in favor of the present era. Let us by no means disparage the efforts of our progenitors, even if their finest workmanship, their illustrated bibles, their Shakspeares, their Miltons, their Goldsmiths and Popes, etc., as compared with our present publications of that class seem gray, smudgy or coarse and their types almost barbarous hieroglyphics. No, let us set a better example for the future typo. In the days of the Revolution and of Franklin our ancestors had to be content and probably were very thankful in obtaining coarse and unsightly materials of whatever description. Down to the year '27 it was in vain type-founders and paper makers complained of the unfavorable appearance of their best and most painstaking productions. Printing as an art was a mere mat-

(2-nick)

12-POINT ROMAN No. 10 (Pica).

In the management of small or large printing establishments, the importance of a correct knowledge as to what constitutes true economy should be attained as speedily as possible; for the obvious reason that hardly any other line of business possesses as many loop-holes for waste and loss. Of course no one enters the printing business to lose money, but many who are now engaged in it have but a limited idea as to its true method of management, and in ignorance as to the causes that conspire against their making money. It is to these persons our remarks will mainly apply, hoping that the few practical suggestions here given may be beneficial to them in their future operations. The more general liability of loss in small offices lies mainly in the carelessness of the employer, or those whom

OUR BODY TYPE STOCK

Is kept in Complete Founts, Sections and Sorts. The Complete Founts are put up in 50s and 100s. The Sections are as follows:

Caps, Small Caps,	Points, Figures,	Lowercase, Odd Sorts,	Leaders, Italic,	Accents, Quads and Spaces.
----------------------	---------------------	--------------------------	---------------------	-------------------------------

By "Odd Sorts" is meant Braces, Dashes, Commercial Marks, References, Fractions, etc. These Sections are each the proper proportion for a 50-lb. fount.

Loose Sorts are kept in neat boxes, and comprise every character of a Roman fount.

It will be seen that through the above convenient arrangement we are enabled to meet any demand with promptness and accuracy; in fact, quicker than the average foundry, where you have to wait for sorts to be cast.

NOTE—In ordering founts, please specify whether Leaders, Italic or Accents are wanted or not.

POSTER ROMANS.

14-POINT ROMAN No. 4 (English).

KING HENRY IV. SHAKSPEARE.

HOTSPUR. Revolted Mortimer! He never did fall off, my sovereign liege, but by the chance of war. To prove that true, needs no more but one tongue, for all those wounds, those mouthed wounds, which valiently he took, when on the gentle Severn's sedgy bank, in single opposition, hand to hand, he did confound the best part of an hour, in changing hardiment with great Glendower! Three times they breathed, and three times did they drink, upon agreement, of swift Severn's flood; who, then, affrighted

Third Act, Scene Second. 1234567890.

18-POINT ROMAN No. 4 (Great Primer).

KING HENRY IV. SHAKSPEARE.

HOTSPUR. Revolted Mortimer! He never did fall off, my sovereign liege, but by the chance of war. To prove that true, needs no more but one tongue, for all those wounds, those mouthed wounds, which valiantly he took, when on the Severn's sedgy bank, in single opposition, hand to hand, he did

Third Act, Scene Second. 1234567890.

Fonts of about 28 pounds complete with quads and spaces at 40 cents per pound.

POSTER ROMANS.

16-POINT POSTER ROMAN.

OF ALL the Bonny Buds that blow, in Bright or Cloudy Weather, Of all the Flowers that come and go the whole twelve months together, this little purple Pansy brings

20-POINT POSTER ROMAN.

OF ALL the Bonny Buds that blow in bright or cloudy weather, of all the Flowers that come and go the whole twelve months together, this

24-POINT POSTER ROMAN.

OF ALL the Bonny Buds that blow in bright and in cloudy weather, Of all the Flowers that come and go

30-POINT POSTER ROMAN.

AMONG the Bonny Buds that blow in the clear or cloudy weath

Fonts of about 28 pounds complete with quads and spaces at 40 cents per pound.

OLD STYLES.

NONPAREIL OLD STYLE NO. 2.

LET me tell you how I write mean letters and bitter editorials, my boy. Sometimes, when a man has pitched into me, and "cut me up rough," and I want to pulverize him and wear his gory scalp at my girdle, and hang his hide on my fence, I write the letter or editorial that is to do the business. I write something that will drive sleep from his eyes and peace from his soul for six weeks. Oh, I do hold him over a slow fire and roast him. Gall and aquaforts drip from my blistering pen. Then I don't mail the letter, and I don't print the editorial. There's always plenty of time to crucify a man. The vilest criminal is entitled to a little reprieve. I put the manuscript away in a drawer. Next day "*I don't know about this. There's a good deal of bludgeon and bowie-knife journalism in that. I'll hold*

IN A FEW humorous remarks recently made at a meeting of the St. Louis Typothetae, Mr. Richard Ennis said that it is with the greatest apprehension that one should undertake to speak in an assemblage composed of the employing printers in this or any other city; for, of all classes of men, they are most inclined to analyze, criticize, reconstruct, strengthen, and "put sense" in all the "matter" with which they come in contact. Whether he be professor or mechanic, politician or preacher, scientist or educator, the average printer feels it but just to "doctor the copy" which passes through his hands, improve the grammar and round the periods with the absolute sway of an autocrat, feeling that no one outside of the printing office has any rights that he is bound to respect. The most printers take no man's statement as gospel, and nothing goes but that which passes his scrutiny. His individuality is supreme and complete, even to the extent of coining words and going outside
1234567890 Six-to-pica leads are used.

abcdefghijklmnopqrstuvwxy

BREVIER OLD STYLE NO. 2.

LABOR-SAVING TINT BLOCKS.—In general work of this class special color blocks have to be provided for each job, which are useless for any other purpose. Besides this it is usually considered necessary in such jobs to work the tints before the black, and this involves a great deal of preliminary work, as the black and color forms must be made to register exactly before the press can be started on the first color form. By using labor-saving tint blocks the expense is greatly reduced, as the same pieces can be used over and over again for different jobs, and, if ordinary care is exercised, the black form can be worked off at once, and the trouble of getting exact register is reduced to a minimum. In displaying a job to be worked in colors *in this manner put the prominent lines in panels of brass rule or border, taking care to have the enclosing rules an equal number*

JOHN A. TAYLOR, who is publishing a paper in Washington Territory, is chuck full of the youthful vigor and enthusiasm that characterizes all new conductors of the editorial pencil. John has several little jobs on hand which he is working up in the ways of reforms. He is trying to show his constituents the hollow emptiness of the seductive circus—trying to persuade them that the glittering splendor of this vanity fair is only tawdry tinsel and cheap paint. But John's people will go to the circus all the same, like John and his handsome wife will themselves, provided the circus man leaves them some tickets. John is also trying to shame the tramp nuisance out of existence, and to make his Western town grow faster than its neighbors. Listen John, to the voice of experience. We have seen the new man rise up in all his vigor to reform mankind, and in the end he fell by the wayside, and the procession filed past him into the big tent. We have heard the young enthusiast in his endeavor to lead his neighbors up to their sense of duty,
1234567890—1234567890

abcdefghijklmnopqrstuvwxy

OLD STYLES.

BOURGEOIS OLD STYLE NO. 2.

THE United Typothetæ of America held its second annual meeting in New York on the 18th of September. From the address of the President, Theodore De Vinne, we make the following excerpt: This organization came not too soon. Other crafts had long ago proved the advantage of a national association. All the important trades we deal with are organized. There are societies of stationers, paper-makers, paper-rulers, and type-founders. The compositors of our offices have been organized for nearly forty years. But that was not enough. There are societies of pressmen and electrotypers, as well as press feeders. We are told by these societies *that they are banded together for our good as well as for their own. I will not challenge that assurance, but I may*

OCCASIONALLY, when it is rendered necessary for engraving purposes to run a type-metal plate in a plaster-of-paris mold, the metal comes out punctured with numerous air and steam holes, not at all like the smooth surface of the plaster in which it has been cast. These undesirable results are caused by the molten metal bubbling like boiling water as soon as it touches the mold, then cooling and hardening full of cavities on the underside where it is intended for engraving. So very objectionable a result can be readily obviated by a few simple precautions. Warm the plaster mold, then fasten it face upward in a shallow cast-iron pan, plunge pan and all into a pot of type-metal, and keep it immersed until the air and steam are no longer given off. Then draw it out, permit it to cool, and separate the plate, and it will be found free from cavities and ready for planing and trimming.

1234567890 1234567890

abcdefghijklmnopqrstuvwxyzz

LONG PRIMER OLD STYLE No. 2 ON SMALL PICA BODY.

PARRHASIUS.—The golden light into the Painter's room streamed richly, and the hidden colors stole from the dark pictures radiantly forth; and, in the soft and dewy atmosphere, like forms and landscapes magical, they lay. The walls were hung with armor; and about, in the dim corners, stood the sculptured forms of Cytheris, and Dian and stern Jove; and from the casement soberly away fell the grotesque, long shadows, full and true; and like a veil of filmy mellow-*ness, the lint-specks floated in the twilight air.*

Parrhasius stood, gazing forget-

PARRHASIUS.—The golden light into the Painter's room streamed richly, and the hidden colors stole from the dark pictures radiantly forth; and, in the soft and dewy atmosphere, like forms and landscapes magical, they lay. The walls were hung with armor; and about, in the dim corners, stood the sculptured forms of Cytheris, and Dian, and stern Jove; and from the casement soberly away fell the grotesque, long shadows, full and true; and like a veil of filmy mellow-*ness, the lint-specks floated in the twilight air.*

Parrhasius stood, gazing forgetfully upon his canvas. There Prometheus lay, chained to the cold rocks of Mount Caucasus; the vulture at his vitals, and the links *of the lame Lemnian fettering in his*

1234567890

abcdefghijklmnopqrstuvwxyzz

1234567890

OLD STYLES.

SMALL PICA OLD STYLE No. 2.

SMALLEST FONT, 25 LBS.

OR 11 POINTS.

FROM ORIGINAL MATRICES.

AN APOSTROPHE TO THE PRINTING PRESS.

BY AN ENTHUSIASTIC COMPOSITOR.

THE PRINTING PRESS! How wonderful was its conception! How marvelous has been its growth! What strides made in the past century! How rapidly has it adapted itself to the increased demands made upon it! Fifty years ago we wondered at the *thousands* of sheets printed in a *month*; but now we behold *millions* of sheets turned out in a single *day*! No other art affords such a comparison.

The printing press! To what historic uses has it been put! Out from its revolving cylinders have come books on every conceivable subject. The scriptures, which had previously been chained in isolated places, to be perused by the few, are now *circulated in millions* throughout the whole earth. The writings of ancient philosophers are now to be found in all parts of the civilized world. Educational literature is brought within the reach of every man, woman and child. Over \$725,000 worth of books are published daily. 1234567890. 1234567890.

abcdefghijklmnopqrstuvwxyz

PICA OLD STYLE No. 2.

SMALLEST FONT, 25 LBS.

OR 12 POINTS.

FROM ORIGINAL MATRICES.

THE IDEAL COUNTY EDITOR.

HIS TRIALS AND TROUBLES.

THE editor who would emblazon the word success on his shield must combine the luminous instinct of common sense with the courage of his honest convictions. As the *chronicler of current local history*, he should "nothing extenuate, nor aught set down in malice." This maxim is worth remembering.

Imbued with Justinian's sense of actual justice—"the perpetual disposition to render to every man his due"—the personalities of journalism, always grateful to the public man, would not be accentuated with the rancor of partisan or personal prejudice, while they might be sufficiently incisive and pungent to satisfy the popular taste for lively criticism. 1234567890. 1234567890.

abcdefghijklmnopqrstuvwxyz

OLD STYLES.

15 A 10 A 30 n 18-POINT OLD STYLE \$5.20
 OUT! OUT! BRIEF CANDLE,
 Life's but a walking shadow, a poor player
 WHO STRUTS HIS HOUR UPON THE STAGE

12 A 8 A 25 a 20-POINT OLD STYLE \$6.40
 PRINT AND PROSPER
 Should be every ASTUTE BUSINESS

8 A 6 A 15 a 30-POINT OLD STYLE \$7.70
 Assist the BLIND Man 2

5 A 4 A 8 n 48-POINT OLD STYLE \$10.00
 Gentle CHILD 8

OLD STYLE ITALIC.

25 A 75 a 6-POINT OLD STYLE ITALIC \$2.40
This is a Lady upon a TIGHT ROPE and her Monkey. She washes with Ivory Soap. 123 Stern Fact.

25 A 75 a 8-POINT OLD STYLE ITALIC \$2.95
Typographic Error: STUPID BOY trying to learn the Printing Business. 47 Cold Truth.

20 A 40 n 10-POINT OLD STYLE ITALIC \$2.40
Kiokley Winkley KANGARIE Fujubi Fujube Fingamarce Mufti Pufti 123

20 A 40 n 12-POINT OLD STYLE ITALIC \$3.05
Florium Zorium BUCKERIBUM Figglety Wigglety 35 Um

12 A 25 a 18-POINT OLD STYLE ITALIC \$3.75
Chicken Foot, ASPARAGUS and Applesauce

10 A 20 n 20-POINT OLD STYLE ITALIC \$4.50
Down in the Depths 'mid the Coral

5 A 8 a 30-POINT OLD STYLE ITALIC \$3.85
The Haywards Journal.

Also, 48-Point Old Style Italic, 6 A 4 A 10 a \$12.40

Hawks & Shattuck, San Francisco.

OLD STYLE EXPANDED.

18 A 36 a 6-POINT OLD STYLE EXPANDED. \$2.90
ARTISTIC AND NEAT DESIGNS
Furnished only by Experienced Workman 456

15 A 25 a 9-POINT OLD STYLE EXPANDED. \$3.05
THE PACIFIC COAST
23 Pictures of Pretty Winter Scenes

12 A 20 a 12-POINT OLD STYLE EXPANDED. \$3.10
TWENTY MAIDS
Romany Rum Rebellion 29

8 A 12 a 18-POINT OLD STYLE EXPANDED. \$4.05
ORNAMENTS
Protean and Art 56

6 A 10 a 24-POINT OLD STYLE EXPANDED. \$5.25
PRAISED
Brown Hats 89

5 A 8 a 30-POINT OLD STYLE EXPANDED. \$6.25
GRADE
37 Pine Logs

4 A 6 a 36-POINT OLD STYLE EXPANDED. \$7.35
PAINT
Fine Red 2

EMERALD NO. 3.

20 A 30 a

6-POINT EMERALD No. 3

\$2 90

IN THE HOMES BEYOND THE BORDER

Several Interesting Problems here Presented for your Consideration
5 Silver Tongued Orators from the Empire State 7

15 A 25 a \$2 25

8-POINT EMERALD No. 3

15 A \$0 85

THE FIRST LOT OF STEEL PENS

That Sold at Wholesale Brought in Fabulous Prices
252 EACH GROSS NETTING NEARLY THIRTY 383

12 A 18 a \$2 30

10-POINT EMERALD No. 3

12 A \$0 95

STRAWBERRY FESTIVALS

Illinois and Michigan Central Railroads
58 KANSAS CITY TRAINS 43

10 A 15 a \$2 90

12-POINT EMERALD No. 3

10 A \$1 15

BRIDGE TENDERS

Carpet Baggers Associations
48 ROMEO AND JULIET 56

8 A 10 a \$3 00

18-POINT EMERALD No. 3

8 A \$1 50

RACE HORSES

Western Newspaper
89 EXAMINED 48

6 A 8 a \$4 50

24-POINT EMERALD No. 3

6 A \$2 10

NECK LACE

Beautiful Stairs
6 SHINE 3

Also, 36-Point, 5 A 6 a \$7 40

Also, 48-Point, 4 A 5 a \$10 00

Hawks & Shattuck, San Francisco.

Digitized by Google

SELF-SPACING OLD STYLES.

6 POINT OLD STYLE No. 27

Price per lb, 68 cts.

In January, 1886, I put in a font of Self Spacing and I am glad to state to you that from the total amount of composition of four compositors for sixty days, I estimate that the saving by increased composition was equal to the whole cost of the type. This favorable showing has induced me to add to the office, this month, four hundred

8-POINT OLD STYLE No. 22

Price per lb, 55 cts.

In January, 1886, I put in a font of Self Spacing and I am glad to state to you that from the total amount of composition of four compositors for sixty days, I estimate that the saving by increased composition was equal to the

9-POINT OLD STYLE No. 28

Price per lb, 50 cts.

In January, 1886, I put in a font of Self Spacing and I am glad to state that from the total amount of composition from four compositors for sixty days, I estimate that the saving by increased composition

10-POINT OLD STYLE No. 24

Price per lb, 48 cts.

In January, 1886, I put in a font of Self Spacing and I am glad to state to you that from the total amount of composition of four compositors for sixty days, I estimate the saving

11-POINT OLD STYLE No. 25

Price per lb, 46 cts.

In January, 1886, I put in a font of Self Spacing and I am glad to state to you that from the total amount of composition of four compositors for sixty days, I estimate the saving

12-POINT OLD STYLE No. 26

Price per lb, 44 cts.

In January, 1886, I put in a font of Self Spacing and I am glad to state to you that from the total amount of composition of four com-

6-POINT OLD STYLE ITALIC No. 27

Circular fonts, \$7.00

In January, 1886, I put in a font of Self Spacing and I am glad to state to you that from the total amount of composition of four compositors for sixty days, I estimate that the saving by increased composition was equal to the whole cost of the type. This favorable showing has induced me to add to the office, this month, four hundred

8-POINT OLD STYLE ITALIC No. 22

Circular fonts, \$5.40

In January, 1886, I put in a font of Self Spacing and I am glad to state to you that from the total amount of composition of four compositors for sixty days, I estimate that the saving by increased composition was equal to the

9-POINT OLD STYLE ITALIC No. 28

Circular fonts, \$4.80

In January, 1886, I put in a font of Self Spacing and I am glad to state that from the total amount of composition from four compositors for sixty days, I estimate that the saving by increased composition

10-POINT OLD STYLE ITALIC No. 24

Circular font, \$4.45

In January, 1886, I put in a font of Self Spacing and I am glad to state to you that from the total amount of composition of four compositors for sixty days, I estimate the saving

11-POINT OLD STYLE ITALIC No. 25

Circular fonts, \$4.20

In January, 1886, I put in a font of Self Spacing and I am glad to state to you that from the total amount of composition of four compositors for sixty days, I estimate the saving

12-POINT OLD STYLE ITALIC No. 26

Circular fonts, \$3.95

In January, 1886, I put in a font of Self Spacing and I am glad to state to you that from the total amount of composition of four com-

TWO-LINE LETTER, 5.

CAST FROM SOLID COPPER MATRICES.

30 A, 9 POINT TWO LINES No. 5. \$1.80
THE AMERICAN JUVENILE HISTORICAL ASSOCIATION 4678

25 A, 10 POINT TWO LINES No. 5. \$1.70
ANNUAL CONCLAVE VETERAN MILITARY HEROES
ILLUMINATED HOLIDAY PRESENTS 123

25 A, 11 POINT TWO LINES No. 5. \$1.95
ADVENTURES OF LITTLE TELEMACHUS 809

20 A, 12 POINT TWO LINES No. 5. \$1.80
SOUTHERN ELECTORAL COMMISSION
COMPARATIVE GEOGRAPHY 567

20 A, 14 POINT TWO LINES No. 5. \$2.10
1234 ELEMENTS OF GEOGNOSY 5678

15 A, 16 POINT TWO LINES No. 5. \$2.10
BRYAN LITERARY ASSOCIATION
8 THE MUSICAL RECORD 6

15 A, 18 POINT TWO LINES No. 5. \$2.30
SCHILLER 8 ART 3 GALLERY

15 A, 20 POINT TWO LINES No. 3. \$3.10
SCULPTURE 9 PROFESSORS
INSURANCE GUIDE 67

TWO-LINE LETTER, 5.

10 A. 22 POINT TWO LINES No. 3. \$2.45
JOLIE RAILROAD GUIDE
83 RAPID TRANSIT

10 A. 24 POINT TWO LINES No. 5. \$3.25
OUR MUSICAL GEMS 4

8 A. 28 POINT TWO LINES No. 5. \$3.10
HOME CULTURIST

6 A. 36 POINT TWO LINES No. 5. \$3.80
THE EXPRESS

5 A. 40 POINT TWO LINES No. 5. \$4.65
ECONOMIST

5 A. 48 POINT No. 5. \$5.50
RICHMOND

TWO LINE LETTER, 6.

25 A, 10 POINT TWO LINES No. 6. \$1.95
PHILOLOGIC KNOWLEDGE TREASURY 5
EDUCATIONAL PUBLICATIONS

20 A, 12 POINT TWO LINES No. 6. \$2.05
LEGENDARY LOGICAL FRAGMENT 8
73 SPIRITUALISM 58

20 A, 14 POINT TWO LINES No. 6. \$2.50
2 AMERICAN PHOTO LANDSCAPE
28 MONONGAHELA 67

16 A, 16 POINT TWO LINES No. 6. \$2.35
PRINTERS PEN MANUALS 8
SPECIMEN BOOK

16 A, 18 POINT TWO LINES No. 6. \$3.05
METROPOLITAN COLLEGE

16 A, 20 POINT TWO LINES No. 6. \$3.30
PRACTICAL GEOMETRY

10 A, 22 POINT TWO LINES No. 6. \$3.00
GOTHIC ORNAMENTS

10 A, 24 POINT TWO LINES No. 6. \$3.85
MARINE REPORTS

CONDENSED No. 2.

25 A, 9 POINT TWO LINE CONDENSED No. 2. \$1.25
LAWS AND REGULATIONS PERTAINING TO MAINE DEER HUNTING
\$48 INSTRUCTIONS FOR AMATEUR SPORTSMEN £82

25 A, 10 POINT TWO LINE CONDENSED No. 2. \$1.50
CARD BOARD AND PAPER BAG MAKERS' ASSOCIATION
456 PROGRESS OF PRINTING 789

25 A, 12 POINT TWO LINE CONDENSED No. 2. \$1.80
PATRIOTISM OF ENGLISH AND SCOTCH COLONISTS
HISTORY OF THE UNITED STATES

20 A, 14 POINT TWO LINE CONDENSED No. 2. \$2.00
LIFE AND WORKS OF WM. M. THACKERY.
BIOGRAPHICAL ANECDOTES

20 A, 16 POINT TWO LINE CONDENSED No. 2. \$2.25
TRAVELS IN THE REALMS OF ALGEBRA
ELEMENTS OF GEOMETRY

15 A, 18 POINT TWO LINE CONDENSED No. 2. \$2.10
NORMAN DANISH GAELIC FLEMISH
HISTORY OF GERMANY

16 A, 20 POINT TWO LINE CONDENSED No. 2. \$2.80
BATHTUB FIRESIDE JOURNAL

10 A, 22 POINT TWO LINE CONDENSED No. 2. \$2.15
OUR REVISED TEXT-BOOKS

CONDENSED No. 2.

10 A.

24 POINT TWO LINE CONDENSED No. 2.

\$2.90

BIOGRAPHICAL SKETCH

10 A.

28 POINT TWO LINE CONDENSED No. 2.

\$3.15

MONOPOLE RACE HORSE

6 A.

36 POINT TWO LINE CONDENSED No. 2.

\$3.15

LITERARY THEMES

5 A.

48 POINT CONDENSED No. 2.

\$4.05

TIMES-UNION

5 A.

60 POINT CONDENSED No. 2.

\$5.35

COAL MINES

4 A.

72 POINT CONDENSED No. 2.

\$7.20

MONTHLY

COMPRESSED.

CAST FROM SOLID COPPER MATRICES.

30 A 50 s., 6 POINT COMPRESSED. \$2.00
DICTIONARY OF LITERATURE AND ART.
Personal Adventures and Travel on Pacific Shores
Historical and Biographical 164

25 A 40 s., 10 POINT COMPRESSED. \$2.30
ELECTROTYPE FOUNDERS
Early History of Paper Manufacture
Progress of the Arts 67

30 A 50 s., 8 POINT COMPRESSED. \$2.90
THE ART OF TYPE FOUNDING
Death of Captain Cook to the Present Time
Voyages round the World

25 A 40 s., 12 POINT COMPRESSED. \$3.30
PRINTER INSTRUCTOR
Winter Flowers of the Andes
Chili Hundreds 34

16 A 30 s., 14 POINT COMPRESSED. \$2.95
Containing Explanations of 178 Terms in Anatomy
CORBIN'S MEDICAL DICTIONARY 381

16 A 25 s., 18 POINT COMPRESSED. \$3.45
Memoir of Napoleon Almanac Bonaparte 1868
MOST ACCURATELY COMPILED

12 A 20 s., 22 POINT COMPRESSED. \$4.00
Winter Camp-life Among the Loggers,
FOREST LIFE AND TREES 18

10 A 15 s., 26 POINT COMPRESSED. \$5.20
History and General Resources
123 EXPLORATIONS 456

8 A 12 s., 36 POINT COMPRESSED. \$5.95
Notes 7 SKETCH 8 Tours

EXPANDED.

Cast from Solid Copper Matrices.

26 A 40 a, 5 POINT EXPANDED No. 3. \$3.15
EUROPE AND AMERICA
History of the Arts and Science of
93 Painting, Sculpture 45

30 A 40 a, 8 POINT EXPANDED No. 3. \$3.85
COMEDY TRAGEDY
Characters of the Theatre
9 Opera Singer 8

30 A 50 a, 6 POINT EXPANDED No. 3. \$3.20
EDUCATION PUBLICATION
A Revised German Translation
Complete Works 86

20 A 30 a 10 POINT EXPANDED No. 3. \$3.55
ENGINEERS
Eminent Mechanics
Stephens 38

16 A 26 a, 12 POINT EXPANDED No. 3. \$4.00
SOLID COMBINATION
Gigantic Telegraphic Monopolies
13 United States 56

10 A 16 a 18 POINT EXPANDED No. 3. \$5.05
SACRED MUSIC
Sunday School Concert
85 Religious 23

5 A 8 a, ORIGINAL 28 POINT EXPANDED No. 3. \$5.00
Scientific School
3 STORIES 5

4 A 6 a, ORIGINAL 40 POINT EXPANDED No. 3. \$7.95
Languages 8
2 LINE 9

CONDENSED OLD STYLE.

CAST FROM SOLID COPPER MATRICES. PATENTED.

25 A 40 s,

12 POINT CONDENSED OLD STYLE.

\$2.40

Coleridge's Religious, Poetical and Dramatic Effusions!
A Complete Literary Work on The Questionable Doctrine of Theopneusy.
47 PHILOSOPHICAL AND THEOLOGICAL OPINIONS

20 A 30 s,

18 POINT CONDENSED OLD STYLE.

\$2.90

Phenomena of the Physical World Explorations
Last Course of Interesting Lectures on Geological Formations
46 HISTORY OF TERRESTRIAL GLOBES 38

15 A 20 s,

24 POINT CONDENSED OLD STYLE.

\$3.80

Ring Bells for the Duchess of Rosemary Lane.
THE SIGN OF THE SILVER FLAGON

10 A 15 s,

36 POINT CONDENSED OLD STYLE.

\$4.50

Earliest Time to the Fall of the Empire
THE PEGOPONNESIAN WAR

6 A 10 s,

40 POINT CONDENSED OLD STYLE.

\$3.95

Antediluvian RUINS the Lost City

6 A 10 s,

48 POINT CONDENSED OLD STYLE

\$5.10

Puritanic ARCHIVES England

CONDENSED OLD STYLE.

CAST FROM SOLID COPPER MATRICES. ORIGINAL.

20A 40s 10 POINT COND. OLD STYLE, No. 2. \$2.45

486 CHRISTMAS PUDDINGS 123
In a Bookselling and Publishing House,
A Very Nice Young Man

25A 40s 12 POINT COND. OLD STYLE, No. 2. \$2.90

HEROINES OF FICTION
American Revolution Romance
35 Border Sketch 92

15 A 25 s.

18 POINT CONDENSED OLD STYLE, No. 2.

\$3.30

Standard Fire and Marine Insurance Company
13 POSTAL UNION CARDS 52

10 A 15 s.

24 POINT CONDENSED OLD STYLE, No. 2.

\$4.30

Plains of the Great Western States
KANSAS 74 OREGON

6 A 10 s.

36 POINT CONDENSED OLD STYLE, No. 2.

\$4.75

Bright and Quaint Fancies
13 SKETCH-BOOK 24

4 A 6 s.

40 POINT CONDENSED OLD STYLE, No. 2.

\$4.06

German HOME Manner

6 A 10 s.

48 POINT CONDENSED OLD STYLE, No. 2.

\$7.80

Patent TYPE Sport

4 A 8 s.

60 OR 48 POINT CONDENSED OLD STYLE, No. 2.

\$6.35

From HONG Kong

OLD STYLE TITLE EXTENDED

CAST FROM SOLID COPPER MATRICES. ORIGINAL.

PATENTED JUNE 22, 1875.

15 A 15 A 20 a, 6 POINT OLD STYLE TITLE EXTENDED. \$2.30

THE MIDDLE WATCH OF THE NIGHT
The Bright, Silver Moon, Twinkling Stars and a Cloudless Sky
TIS THE HOUR OF FAIRY BAN AND SPELL
POLITICAL ECONOMY.

15 A 15 A 20 a, 8 POINT OLD STYLE TITLE EXTENDED. \$2.95

A GLITTERING ARCH OF SILVER
The Dim Mortal Bounds of Our Elfin Fairy Land
DOOM OF THE CULPEPPER

12 A 12 A 15 a, 10 POINT OLD STYLE TITLE EXTENDED. \$2.95

SCIENTIFIC ADVANTAGES
Sublime Harmonies of Natural History
BURLESQUE BOTANISTS

10 A 10 A 15 a, 12 POINT OLD STYLE TITLE EXTENDED. \$3.65

CELESTIAL SCENERY
Professional Starry Researches
AMONG THE ASTEROIDS
Babbling Brooks.

CONDENSED OLD STYLE ITALIC No. 2.

PATENTED

20 A 40 a, 10 POINT CONDENSED OLD STYLE ITALIC, No. 2. \$2.00

*Of all the causes which conspire to blind
Man's erring judgment, and misguide the mind,
What the weak head with strongest bias rules,
Is pride, the never-failing vice of fools.*
345 POPE'S ESSAY ON CRITICISM 678

20 A 40 a, 12 POINT CONDENSED OLD STYLE ITALIC No. 2. \$3.25

*You scorn what lies before you in the page
Of nature and experience, moral truth;
And dive in science for distinguish'd names,
Sinking in virtue as you rise in fame.*
48 YOUNG'S NIGHT THOUGHTS 56

TITLE COMPRESSED

CAST FROM SOLID COPPER MATRICES.

30 A, 12 POINT TITLE COMPRESSED \$2.95
MEMORIES OF A HAPPY NEW ENGLAND YEAR WHICH HAS JUST PASSED

20 A, 18 POINT TITLE COMPRESSED \$2.65
15 MAGNIFICENT BRIGHTLY COLORED WOOD ILLUSTRATIONS

20 A, 22 POINT TITLE COMPRESSED \$2.90
MODEL MORAL MANAGEMENT OF CHILDREN IN INFANCY

15 A, 24 POINT TITLE COMPRESSED \$3.00
51 ECCLESIASTIC THEOLOGICAL LITERATURE 34

10 A, 36 POINT TITLE COMPRESSED \$3.65
PHILOSOPHY HISTORY MATHEMATICS

8 A, 40 POINT TITLE COMPRESSED \$3.30
ADVENTURE IN ANCIENT TURKEY

6 A, 48 POINT TITLE COMPRESSED \$3.20
HISTORY OF THE INSURRECTION

6 A, 60 POINT TITLE COMPRESSED ON 48 POINT BODY \$2.95
GEOLOGICAL 85 MAELSTROM

4 A, 72 POINT TITLE COMPRESSED ON 60 POINT BODY \$3.20
FARMINGTON INDUSTRY 6

ALDINE.

CAST FROM SOLID COPPER MATRICES.

30 A 50 a,	5 POINT ALDINE.	\$2.05	30 A 50 a,	NONPAREIL ALDINE.	\$2.10
Cupid's Expedition to Explore the Termination of all True Love SKETCHES OF LIFE AND CHARACTER 845			Nice Discrimination Should be Used in Selecting FIRST-CLASS PRINTING OFFICES 342		

30 A 50 a, 8 POINT ALDINE. \$2.75
DARING INDIAN RAIDS OF BRONZED MEXICAN GREASERS
A Charge Equalled Only by the Unparalleled Bills of a Saratoga Café Proprietor.
984 Devilish Delight of 'Ansome 'Arry. 257

20 A 30 a, 10 POINT ALDINE. \$2.20
MAY BLOSSOM'S TOYS AND PICTURE BOOKS
Quaint Sayings Manners and Customs of the Merry Little Chicks
835 Pretty Little Dark Blue Eyes 246

20 A 30 a, 12 POINT ALDINE. \$3.00
INCIDENTS AND INFERNAL PLOTS
Random Sketches and Notes by the Herald Reporters
46 Interesting General News 23

20 A 30 a, 14 POINT ALDINE. \$3.65
PIRATICAL PASTRY POTENTATE
Sermons by the Gormandizing Harlem Pie Eater
27 Deluded Dyspeptics 38

15 A 25 a, 18 POINT ALDINE. \$3.75
Our 34 Heathen Chinee Bible Societies 59
VALUABLE CONTRIBUTIONS

12 A 20 a, 22 POINT PICA ALDINE. \$4.60
Brass Faucets, Lamp Fixtures, Etc.
86 MANUFACTURERS 75

ALDINE.

8 A 15 a.

28 POINT ALDINE.

\$5.50

BOTANIC SCIENCE
Exhaustive 6 Researches
5 Demonstrated 8

8 A 12 a.

36 POINT ALDINE.

\$7.85

Boston 512 Commons
CLUB HOUSE

6 A 10 a.

40 POINT ALDINE.

\$7.55

Robert Browning 3
TROSACH

6 A 10 a.

48 POINT ALDINE.

\$10.50

Can 6 SEA 8 Run

3 A 5 a.

60 POINT ALDINE ON 48 POINT BODY.

\$6.65

Name 3 Doves

CONDENSED ALDINE.

CAST FROM SOLID COPPER MATRICES.

PATENTED.

- | | | |
|--|----------------------------|--------|
| 40 A 50 a, | 6 POINT CONDENSED ALDINE. | \$2.00 |
| Guide through France, Belgium, Holland, Germany, Italy, Sicily, Spain, Great Britain and Ireland
An Authorized Exhaustive Treatise on the Interesting Subject of How to Make an Economical Tour on the Eastern Continent
346 HAND-BOOK FOR TRAVELERS IN EUROPE AND THE EAST 758 | | |
| 40 A 50 a, | 8 POINT CONDENSED ALDINE. | \$2.25 |
| Being the Work adopted by the University of France for Instruction
In the Colleges High Normal Schools and Other Educational Institutions of the Parisian Municipality
12345 EPITOME OF THE HISTORY OF PHILOSOPHY 67890 | | |
| 40 A 50 a, | 9 POINT CONDENSED ALDINE. | \$2.00 |
| Review of the Progress and Influence of the Arts Embracing a
Treatise and an Exhaustive Opinion of Vernet With Notices of the Works of Celebrated Artists
18. OUTLINE HISTORY OF THE FINE ARTS 82 | | |
| 30 A 40 a, | 10 POINT CONDENSED ALDINE. | \$2.20 |
| Ships Rounding Cape Horn in Fierce Mid-Winter Storms
Islands of the Australasian Seas, during a Cruise Under Captain Benjamin Morrell
345 ADVENTURES IN THE PACIFIC OCEAN 678 | | |
| 30 A 40 a, | 12 POINT CONDENSED ALDINE. | \$2.80 |
| Manners, Religion, Literature, and Social Condition of the Greeks
Thirteen Learned Professional Educators of Southern European Provinces
12 LIFE AND TRAVELS OF HERODOTUS 34 | | |
| 20 A 30 a, | 14 POINT CONDENSED ALDINE. | \$2.40 |
| Consisting of Letters and Papers Relating to the Contest for Liberty
80 GIBBS' FRENCH DOCUMENTARY HISTORY 75 | | |
| 20 A 25 a, | 18 POINT CONDENSED ALDINE. | \$3.00 |
| Remarkable Traits and Humors of the Alleged Comical Man
56 OLD COMMERCIAL ANECDOTES 34 | | |

CONDENSED ALDINE.

CAST FROM SOLID COPPER MATRICES.

PATENTED.

15 A 20 a, 22 POINT CONDENSED ALDINE. \$3.25
Elements of Moorish and Egyptian Architecture
12 MISCELLANEOUS QUESTIONS 34

10 A 15 a, 28 POINT ALDINE. \$3.90
Núñez Comisióu de Cámara á la Ramón
12 FRANÇAIS CAÑONS. 45

10 A 15 a, 40 POINT ALDINE. \$6.00
Upton Military Instruction Manual
23 INTELLECTUALITY 25

6 A 10 a, 48 POINT CONDENSED ALDINE. \$4.55
Treating GASTRIC Elements

5 A 8 a, 60 POINT CONDENSED ALDINE ON 48 POINT BODY. \$6.00
8 Troubles SIN Dressed 3

4 A 8 a, 72 POINT ALDINE CONDENSED ON 60 POINT BODY. \$6.75
Great COUNTER Sales

BOLDFACE AND ITALIC.

CAST FROM SOLID COPPER MATRICES.

30 A 60 a, 6 POINT BOLDFACE ROMAN. \$2.60
Though Printing be considered a Modern Invention,
It is allowed to have been practiced in the East from a very Early Period. It has been
51 SECLUSION OF THE CHINESE 29

30 A 50 a, 7 POINT BOLDFACE ROMAN. \$3.00
According to the Common Traditions of the Hærlmites,
It appears that the Art of Printing was first introduced there; but now the
83 SCHEMERS CLAIM ORIGINALITY 18

30 A 50 a, 8 POINT BOLDFACE ROMAN. \$3.60
It is a matter of surprise that the Discovery of the
Art of Printing having been made so recently that no certain
24 TREATISE ON PRINTING 13

25 A 40 a, 10 POINT BOLDFACE ROMAN. \$3.25
To commence Printing an Edition of the
Holy Bible in the Early Period of the Art Preservative
67 LUDOVICO GUICCIARDINI 15

20 A 30 a, 12 POINT BOLDFACE ROMAN. \$3.95
In 1450 Faust and Guttemberg entered into
THE ADVANCEMENT OF ART

30 A 50 a, 6 POINT BOLDFACE ITALIC. \$2.60
It is not certain that he did more than supply the money for the Concern.
John Fust, or Faust, was one of the three artists considered as the Inventors of Printing.
62 FAUST AS A PROMOTER OF THE ART 14

30 A 50 a, 8 POINT BOLDFACE ITALIC. \$3.25
*In 1462 Faust and Schæffer printed a number of
Bibles, and disposed of them in Paris; the price is said to have been*
36 FIVE HUNDRED CROWNS 15

25 A 40 a, 10 POINT BOLDFACE ITALIC. \$3.35
*We have been informed that the Mentz Printers
Administered an Oath to all whom they employed; this*
21 WAS CONTINUED UNTIL 46

20 A 30 a, 12 POINT BOLDFACE ITALIC. \$3.60
England introduced the Printing Art in 744
58 INTRODUCTION 29

ELEPHANT AND MODERN TITLE.

CAST FROM SOLID COPPER MATRICES.

50 A 75 a, 5 POINT ELEPHANT. \$4.95

We are informed that John Preston printed a Book at Goa in 1577
Our Ambassador to Morocco, assures us that there is not a Printing Office in the Territory
567 EARLY TYPOGRAPHIC TRIBULATIONS 284

30 A 50 a, 6 POINT ELEPHANT. \$2.60

Some old Danish Missionaries are said to have sent a Printing
Press and several workmen to Tranquebar ; where they printed Prayer Books, Etc
75 METEOROLOGICAL CALCULATIONS 14

30 A 50 a, 7 POINT ELEPHANT. \$3.50

John Euschedius, a printer, discovered an old
Parchment Horarium, containing the Lord's Prayer and Creed
63 ANCIENT PRINTING OFFICE 14

30 A 50 a, 8 POINT ELEPHANT. \$3.85

The earliest Production from the Peruvian
Press was printed at Limarena by Pablo L. de Arriago, in 1621
50 ADVANCE OF PRINTING 16

25 A 40 a, 10 POINT ELEPHANT. \$3.50

The second Newspaper which was issued in
America appeared in Boston on December 21, 1719
40 AMERICAN JOURNALISM 17

18 A 25 a, 12 POINT ELEPHANT. \$3.35

Boston claims the credit of issuing the 1st
NEW BOSTON LETTERS

30 A 50 a, 6 POINT MODERN TITLE. \$2.40

Archibald Binny was a native of Scotland, in which country he had, after
Becoming a Printer, conducted the business of Type Founding on a limited scale at Edinburgh,
and Emigrated to the United States about 1795.

2386 TYPE FOUNDING AND ITS IMPROVEMENTS 9220

20 A 15 A 30 a, 12 POINT MODERN TITLE. \$4.90

CO-OPERATIVE BUILDING ASSOCIATION
Excellent Opportunities for Safe Investments
\$5.00 SHARES \$5.00

TITLE ITALIC AND HALF TITLE.

CAST FROM SOLID COPPER MATRICES.

30 A 50 s, 6 POINT TITLE ITALIC. \$2.60
*Of all discoveries made, we conceive the reflecting mind will admit,
that none have tended more to the improvement and comfort of society than Printing*
THE NEW YORK DAILY NEWS.

25 A 40 s, 8 POINT TITLE ITALIC. \$3.15
*Of all the discoveries which have been made, the
reflecting mind will admit, that none have tended more to the*
SCIENTIFIC AMERICAN.

25 A 40 s, 10 POINT TITLE ITALIC. \$3.30
*Of all the discoveries which have been made,
none have tended more than Printing to improve society*
PRINTERS' WAREHOUSE.

15 A 25 s, 12 POINT TITLE ITALIC. \$3.35
Of all the discoveries which have been made
AMERICAN MEMORIAL.

30 A, 6 POINT HALF TITLE. \$1.45
OF ALL MODERN INVENTIONS OR DISCOVERIES NONE HAVE MADE MORE
58 RAPID STRIDES THAN PHOTO-ENGRAVING 25

25 A, 8 POINT HALF TITLE. \$1.60
IF IT BECOMES NECESSARY TO LAY IN A STOCK OF TYPE,
58 INVESTIGATE OUR FACILITIES 94

25 A, 10 POINT HALF TITLE. \$1.85
STANDARD AMERICAN FOUNDRY PRODUCTION
34 SELECT FRENCH DESIGN 78

20 A, 11 POINT HALF TITLE. \$1.95
AMERICAN STEREOTYPER'S JOURNAL
BOSTON NEWSPAPERS

20 A, 12 POINT HALF TITLE. \$2.25
SOCIETY FOR PROTECTING BEES
12 HOUSEMAIDS 34

INCLINED FACES.

PATENTED.

30 A 60 s, 6 POINT INCLINED BOLDFACE. \$2.35
Bradstreet Reports 8751 Celestial Merchants in San Francisco
Establishment of Chinese Emigration and Commercial Relations with the European Nations
38 THE ANGLO-CHINESE LANGUAGE 24

30 A 60 s, 8 POINT INCLINED BOLDFACE. \$3.15
American Contributions to Food, Industry and Art
The West is Surpassed by no other Part of the World in Grain Growing
18 COMMERCIAL PRODUCTS 90

25 A 40 s, 10 POINT INCLINED BOLDFACE. \$3.15
Elements of Science, Rhetoric and Composition
Anecdotal Biographies of all the Leading American Authors
18 AMERICAN LITERATURE 89

20 A 40 s, 12 POINT INCLINED BOLDFACE. \$3.60
The United States Business Directory
Electrical Inventions of Prominent Americans
2 EDISON'S TELEPHONE 4

25 A 40 s, 8 POINT BACK SLOPE TITLE. \$2.25
We hold these truths to be self-evident—that all men are created equal; that they are endowed by their Creator with certain inalienable rights;
58 REPUBLICAN GOVERNMENT. 18

15 A 25 s, 10 POINT BACK SLOPE TITLE. \$2.55
We hold these truths to be self-evident—that all men are created equal; that they are endowed by
58 AMERICAN UNION. 18

15 A 25 s, 12 POINT BACK SLOPE TITLE. \$3.35
Of all discoveries, none have tended more to improve art and society than Printing
8 NATIONAL MAGAZINE 5

OLD STYLE ANTIQUE.

30 A 50 s. 6 POINT OLD STYLE ANTIQUE. \$2.45
Wholesale Destruction of the Numerous Implements of the Theatrical Stage
How We Arranged and Managed Our Private Evening Entertainments in a Country Village
645 SERIES OF LITTLE PLAYS FOR LITTLE FOLKS 723

30 A 50 s. 8 POINT OLD STYLE ANTIQUE. \$2.70
History of the United States of America, Complete in Six Volumes
A Collection of Orations and Speeches of Daniel Webster the American Statesman
64 MASTERLY ARGUMENT AND ELOQUENCE 51

25 A 40 s. 10 POINT OLD STYLE ANTIQUE. \$3.00
Farmers, Agriculturists, Stock and Poultry Jobbers
The Centennial Exposition of the Ohio Valley and Central States
1878 EVERY HUNDRED YEARS 1875

20 A 30 s. 12 POINT OLD STYLE ANTIQUE. \$3.00
Compared with Fascinating Extravanzas in Fiction
456 A SINCERE SCHOLAR 123

12 A 20 s. 18 POINT OLD STYLE ANTIQUE. \$3.80
The Brownies and Their Quaint Book
123 MAGAZINES 679

10 A 15 s. 22 POINT OLD STYLE ANTIQUE. \$4.25
Three Brown Boys Fairy Tale
42 YULE LOG 67

8 A 12 s. 28 POINT OLD STYLE ANTIQUE. \$5.45
New Homestead Books
31 LEISURE 70

IONICS

— CAST FROM ORIGINAL MATRICES —

- 30 A 50 a, 6 POINT IONIC \$2.60
CIVILIZING INFLUENCES OF EDUCATION
True Episodes of French History during the Consulate and the First Empire
35 Enlightened France 37
- 30 A 50 a, 8 POINT IONIC \$3.60
DISCOVERY OF LAKE SHIRWH
Narrative of an Expedition to the Region of the Zambesi
35 Charles Livingstone 26
- 20 A 30 a, 10 POINT IONIC \$2.70
TRAVELLERS IN ARMENIA
Valuable Discoveries among the Ruined Cities
68 Relic Hunter 25
- 15 A 25 a, 12 POINT IONIC \$3.05
INTERIOR OF AFRICA
Anecdotes of the Chase of the Gorilla
24 Giraffe Hunters 58
- 15 A 30 a, 18 POINT IONIC \$4.90
INCOMPREHENSIVE
Series of Explanatory Grammar
57 Studious 23
- 12 A 25 a, 22 POINT IONIC \$5.85
Constitutional Reformation
25 DIFFICULT 84

ANTIQUÉ CONDENSED.

CAST FROM SOLID COPPER MATRICES.

- 30 A 50 a, 6 POINT ANTIQUÉ CONDENSED No. 4. \$2.10
ELABORATE ACCOUNT OF THE RECENT DISCOVERIES AT NINEVEH
Duer's Exhaustive Lectures on the Constitutional Jurisprudence of the United States of North America
1718 Illustrations of Ancient American Arts. 1875
- 30 A 50 a, 8 POINT ANTIQUÉ CONDENSED No. 4. \$2.05
PRETTY STORIES FOR OUR YOUNG PEOPLE
The Origin, Formation, Discussion, Revision and Final Adoption of the Constitution
89 Homes and Haunts of British Poets. 75
- 20 A 30 a, 10 POINT ANTIQUÉ CONDENSED No. 4. \$2.05
HOUSE AND SENATE OF THE UNITED STATES
Adventures and Historical Researches in Mexico and Central America
51 and their Silver Mines. 18
- 20 A 30 a, 12 POINT ANTIQUÉ CONDENSED No. 4. \$2.80
THE LANGUAGE OF FLOWERS
Biographical and Historical Sketches of the State of Virginia
75 Pioneers of Richmond 93
- 15 A 25 a, 18 POINT ANTIQUÉ CONDENSED No. 4. \$3.30
COMPLETE OCTAVO DICTIONARY
Origin and Definitions of 963 Enigmatical Words
35 Introductory Preface 24
- 12 A 20 a, 22 POINT ANTIQUÉ CONDENSED No. 4. \$3.80
BIOGRAPHICAL SUBJECTS
United States and Foreign Mail Service
International Postage 53
-

N. C. HAWKS, SAN FRANCISCO.

Digitized by Google

ANTIQUE CONDENSED.

10 A 15 s.

28 POINT ANTIQUE CONDENSED No. 4.

\$4.80

RHETORIC 4 GRAMMAR
American Authentic Dictionary

8 A 12 s.

36 POINT ANTIQUE CONDENSED No. 4.

\$6.30

PRINT 78 PRESS
United Letter Founders

4 A 8 s.

40 OR 48 POINT ANTIQUE CONDENSED No. 4.

\$6.90

YORKVILLE
Rowing 5 Regatta

6 A 10 s.

48 POINT ANTIQUE CONDENSED No. 4.

\$8.65

Man INDIANS Rail

5 A 8 s.

60 POINT ANTIQUE CONDENSED No. 4.

\$9.60

Hat ROME Colt

ANTIQUE CONDENSED No. 5.

CAST FROM SOLID COPPER MATRICES. ORIGINAL.

20 A 30 a.

12 POINT ANTIQUE CONDENSED No. 5.

\$1.65

**Thrilling Campaigns and Stories by the Old Continental Soldiers
Trials and Hardships of Harvey Birch in the Fierce Struggle for American Independence
15 Massachusetts 68
SOLDIERS AND PATRIOTS OF THE REVOLUTION**

15 A 25 a.

18 POINT ANTIQUE CONDENSED No. 5.

\$2.10

**New England Home Life a Hundred Years Ago
Professors of Mesmerism, Spiritualism, Sorcery, Witchcraft,
12 American 34
HISTORICAL FRENCH REMINISCENCES**

12 A 20 a.

24 POINT ANTIQUE CONDENSED No. 5.

\$3.30

**Great Authors of New England
Comprehensive Selections from the Publication
EDUCATIONAL INSTITUTION**

8 A 12 a.

36 POINT ANTIQUE CONDENSED No. 5.

\$3.60

**Our South American Settlements
Notes on the Virginian Indian Wars
78 SOUTHERN MANNERS 54**

ANTIQUE CONDENSED No. 5.

CAST FROM SOLID COPPER MATRICES. ORIGINAL.

6 A 10 a.

40 POINT ANTIQUE CONDENSED No. 5.

\$3.85

**The United States Historic
Recorder and Statistical Compiler
45 IMPORTERS 63**

6 A 10 a.

48 POINT ANTIQUE CONDENSED No. 5.

\$6.50

**Considered Letters
Legal Documents Series
15 HISTORIES 78**

5 A 8 a.

60 POINT ANTIQUE CONDENSED No. 5.

\$7.55

**Handsome Gardens
23 SUMMER 54**

ANTIQUES No. 6.

CAST FROM SOLID COPPER MATRICES.

- 30 A 50 a, 6 POINT ANTIQUE No. 6. \$2.90
In the early Hebrew Manuscripts the custom of Abbreviating
Common or Proper Words was carried to such an extent that only the Most Expertly
12 ORIGIN AND HISTORY OF PRINTING 34
- 30 A 50 a, 8 POINT ANTIQUE No. 6. \$3.00
From time to time new methods of Engraving, and
Various plans for cheapening and improving the processes of Zincography
56 ENCYCLOPEDIA OF PRINTING 78
- 30 A 50 a, 9 POINT ANTIQUE No. 6. \$3.30
Ancient History shows that from time immemorial
Men have attempted to Revolutionize the Customs of their Fathers
12 TREATISE ON ENGRAVING 34
- 25 A 40 a, 10 POINT ANTIQUE No. 6. \$3.35
What may be styled Amateur Printing?
Enthusiastic Followers of the Art Preservative of Others
36 TYPOGRAPHICAL 24
- 20 A 30 a, 12 POINT ANTIQUE No. 6. \$3.85
The Points now used in Punctuation
Introduced into Writing in Year of Our Lord
CHRISTOPH 123 COLUMBUS
- 10 A 20 a, 18 POINT ANTIQUE No. 6. \$3.80
California Merchandising Trades
16 AUCTIONEERS 42
- 10 A 20 a, 22 POINT ANTIQUE No. 6. \$5.80
Old Commanding Officers
4 BATTLE FLAGS 8

ANTIQUES.

8 A 15 s.

24 POINT ANTIQUE No. 2.

\$6.50

Select Music Album
27 SCORES 45

6 A 10 s.

28 POINT ANTIQUE No. 2.

\$6.30

Mortal Statistics
6 GOLD 3

6 A 10 s.

36 POINT ANTIQUE.

\$11.10

Messengers
2 LIGHT 8

4 A 6 s.

48 POINT ANTIQUE.

\$10.80

Tide Mate
3 SHIP 9

4 A 6 s.

60 POINT ANTIQUE ON 48 POINT BODY.

\$12.40

Democrat

ANTIQUE EXTENDED No. 2

CAST FROM SOLID COPPER MATRICES.

26 A 40 s. 6 POINT ANTIQUE EXTENDED No. 2 \$4.20

BEAUTIFUL CHRISTMAS CAROLS
A New Art, Literary, Musical and Business Journal
543 Choice Extracts 688

20 A 30 s. 8 POINT ANTIQUE EXTENDED No. 2 \$4.00

RECONSTRUCTION PARTIES
The Nebraska Horticultural Association
32 Vernet Domain 54

16 A 20 s. 10 POINT ANTIQUE EXTENDED No. 2 \$3.50

MANHATTAN HOTELS
Time of Closing New York Mails
83 Post Office 65

16 A 20 s. 12 POINT ANTIQUE EXTENDED No. 2 \$4.50

ENGLISH COMPS
United States Post Office
1234567890

6 A 8 s. 22 POINT ANTIQUE EXTENDED No. 2 \$3.90

INSURANCE
Inspect 5 History

6 A 6 s. 28 POINT ANTIQUE EXTENDED No. 2 \$6.45

Modern Art

6 A 5 s. 40 POINT ANTIQUE EXTENDED No. 2 \$10.00

Church 3

FRENCH ANTIQUE EXTENDED.

CAST FROM SOLID COPPER MATRICES.

25 A 40 a, 5 POINT FRENCH ANTIQUE EXTENDED. \$3.25
Specimens of Decorations of the Nineteenth Century
Beautiful Landscape and Marine Paintings by a Few Notable English Artists
12345 ARTISTIC ORNAMENTATION 67890

25 A 40 a, 6 POINT FRENCH ANTIQUE EXTENDED. \$2.90
Ten Lectures on the Philosophy of Spiritualism
Ghostly Visitations from the Realms of the Present Great Unknown
12 MODERN SUPERSTITION 34

20 A 30 a, 8 POINT FRENCH ANTIQUE EXTENDED. \$2.70
The German and English Expedition
Foreign Explorations by 543 Youthful Adventurers
678 Hindoostan 219
WAR CORRESPONDENTS

15 A 25 a 10 POINT FRENCH ANTIQUE EXTENDED. \$2.95
French and English Lexicon
Whitcomb Common School Grammar
234 College 567
CEREAL PRODUCTION

12 A 20 a, 12 POINT FRENCH ANTIQUE EXTENDED. \$3.90
Novel Pencil Sketches
Prominent Artists of Europe
54 Pictures 37
ART GALLERIES

EGYPTIAN.

CAST FROM SOLID COPPER MATRICES.

30 A 50 s. 6 POINT EGYPTIAN. \$1.80

RELIABLE INFORMATION AND GUIDE BOOK TO THE HIDDEN SECRETS OF MAMMOTH CAVE

Personal Narrative and Results of a Prolonged Travel through the Sandwich or Hawaiian Islands with a Party of Fiji Islanders

Exciting Adventures of Timothy Trundlebed

7415 Illustrated and Related with a Keen Sense of Paralyzing Humor 2345

30 A 50 s. 8 POINT EGYPTIAN. \$2.35

BLOOD CURDLING ADVENTURES OF JIM ROBINSON CRUSOE

Historical and Descriptive Account of the Farce Islands, Elegantly Bound in Bob Veal

1 2 3 4 5 6 7 8 9 0 9 8 7 6 5 4 3 2 1

976th Annual New York Cattle and Poultry Exhibition

25 A 40 s. 10 POINT EGYPTIAN. \$2.60

ENTERPRISING BANKERS AND COMMISSION BROKERS

Metropolitan Fire and Marine Insurance Company of Hartford, Boston, Mass.

Capital and Fish Net Surplus, \$450,000

Philadelphian Industrial Kindergarten Departments

15 A 25 s. 12 POINT EGYPTIAN. \$2.30

ATLANTIC TELEGRAPH COMPANIES

Mineral and Botanic Resources of the United States Gov't

Stocks 1 2 3 4 5 6 7 Bonds

Bears, Margins, Options, Puts and Calls

15 A 25 s. 18 POINT EGYPTIAN. \$3.15

ENGRAVING ON WOOD AND METAL

American Geographical and Statistical Society 64

New York Tract Society Publication.

EGYPTIAN.

10 A 20 a.

22 POINT EGYPTIAN.

\$4.00

EGYPTIAN MONUMENTS
New York Typographical Celebration
American Society 85

8 A 15 a.

28 POINT EGYPTIAN.

\$4.00

MANUFACTURERS
Science and Mechanics Journal
18 Illustrated 75

8 A 12 a.

36 POINT EGYPTIAN.

\$7.15

CONSTANTINE
Manhattan Insurance
Company 57

6 A 10 a.

48 POINT EGYPTIAN.

\$8.95

MONITORIAL
Business Directory

EGYPTIAN CONDENSED SHADED.

PATENTED

12 A 20 s.

18 POINT EGYPTIAN CONDENSED SHADED.

\$4.25

Chamois of the Forests and Mountains of Switzerland

12 MIDSUMMER RAMBLINGS 34

10 A 15 s.

22 POINT EGYPTIAN CONDENSED SHADED.

\$4.50

American Manners and Customs Described by

12 MATTHEW ARNOLD 34

8 A 12 s.

28 POINT EGYPTIAN CONDENSED SHADED.

\$5.60

Philadelphia Centennial Exposition

18 INDEPENDENCE 76

6 A 8 s.

40 POINT EGYPTIAN CONDENSED SHADED.

\$7.25

Sketches of Historic Men

2 MONMOUTH 6

4 A 6 s.

48 POINT EGYPTIAN CONDENSED SHADED.

\$7.75

Elements of History

2 SCIENCE 3

BODWELL.

20 A

12-POINT BODWELL

\$1.90

JOURNALIST BRAIN SUPPLY @ MERCHANTS' STEAMBOAT GUIDE
12345 ✕ FARM AND GARDEN ✕ 67890

15 A

18-POINT BODWELL

\$2.40

EXPERT STEVEDORES' LEAGUES AND ASSOCIATIONS
5 ✕ FIRE AND MARINE INSURANCE @ ✕ 8

12 A

24-POINT BODWELL

\$3.25

ARTIST PRINTERS, THROW YOUR EYES
12 ✕ ON THIS ✕ 34

8 A

30-POINT BODWELL

\$3.50

SPRING VALLEY BASE-BALLERS

6 A

36-POINT BODWELL

\$3.85

GRIZLY BEAR MONARCH

5 A

48-POINT BODWELL

\$4.75

CALIFORNIA PRIDE

GOTH.

50 A

6-POINT GOTH

\$2.00

REST OR REPOSE OF MIND, RESULTING FROM A FULL BELIEF OF THE
VARACITY OR INTEGRITY OF A PERSON. 1234567890

40 A

8-POINT GOTH

\$2.25

A LOAN OF MONEY TO A MAN EMBARRASSED MAY
AFFORD HIM A TEMPORARY RELIEF 1234567890

30 A

10-POINT GOTH

\$2.25

THE QUALITY OF MERCY IS NOT STRAINED;
IT DROPPETH AS THE GENTLE RAIN FROM

30 A

12-POINT GOTH

\$2.65

IT IS TWICE BLESSED, IT BLESSETH
HIM THAT GIVES AND HIM THAT TAKES,

18 A

18-POINT GOTH

\$3.15

IT BECOMES THE
THRONED MONARCH BETTER

12 A

24-POINT GOTH

\$3.35

HIS SCEPTRE
SHOWS THE FORCE

NORMAN CONDENSED.

30 A 8-POINT NORMAN CONDENSED \$1.45
OUR LITTLE POLLY IS DEAD, AND THE FEATHERS ON HER HEAD WILL
NEVER FLUTTER UP ABOVE THE DOOR

20 A 20 A 10-POINT NORMAN CONDENSED \$2.00
FOR THE BLACK HEN BELTED HER WITH HER LITTLE CROOKED
SPUR, AND POLLY DON'T WANT A CRACKER ANY MORE.

15 A 15 A 12-POINT NORMAN CONDENSED \$2.15
A BUMBLE-BEE BELTED WITH BROWN AND GOLD
ON A PURPLE 7680 CLOVER SAT

12 A 12 A 18-POINT NORMAN CONDENSED \$2.45
COLMAN'S NORTH BEACH MUSTARD CO.
18 BURR'S EXPORTATION 90

10 A 10 A 20-POINT NORMAN CONDENSED \$3.10
AMERICAN REVOLUTION STORY
23 LEXINGTON 54

8 A 8 A 24-POINT NORMAN CONDENSED \$3.30
IN MEMORY OF FRANKLIN
17 INDEPENDENCE HALL 76

6 A 6 A 36-POINT NORMAN CONDENSED \$4.50
NORMAN CONDENSED!
11 HANDSOME 22

GOTHIC CONDENSED No. 5.

- 30 A 50 a 6-POINT GOTHIC CONDENSED No. 5. \$1.90
THE MAYOR OF A CITY, IN AMERICA, IS THE CHIEF JUDGE OF THE CITY COURT, AND IS ASSISTED,
In some cases at least, by two Aldermen, sometimes known as Boodlers. \$1234567890
- 30 A 50 a 8-POINT GOTHIC CONDENSED No. 5. \$2.50
THE PITH OF THE SUNFLOWER AND LILAC, WHICH HAS NEITHER TASTE NOR SMELL,
Is Insoluble in Water, Ether, Alcohol and Oils. 1234567890
- 25 A 40 a 10-POINT GOTHIC CONDENSED No. 5. \$2.35
PAGAN, TO DISTINGUISH ONE FROM CHRISTIAN OR MOHAMMEDAN
Tent Life on the Arabian Deserts among the Sheiks 12345
- 20 A 30 a 12-POINT GOTHIC CONDENSED No. 5. \$2.65
OUR AIM IS TO EXCEED IN SPLENDID APPEARANCE
Standard Faces Have the Preference 12345
- 15 A 25 a 18-POINT GOTHIC CONDENSED No. 5. \$2.85
FROM CIRCUMSTANCES WE FORM OUR OPINIONS
Respecting Events of the Future 12345
- 12 A 20 a 22-POINT GOTHIC CONDENSED No. 5. \$3.25
CONTENT THYSELF TO BE OBSCURELY GOOD
And Never Cheat the Printer 12345
- 10 A 15 a 28-POINT GOTHIC CONDENSED No. 5. \$4.20
QUICK, TIDY AND LIGHT IN MOTION
Insulated Electric Motors \$123
- 8 A 12 a 36-POINT GOTHIC CONDENSED No. 5. \$5.35
AMERICA'S PROUD BOAST
Public Schools \$1234

GOTHIC ITALIC No. 2.

25 A 40 a 8-POINT GOTHIC ITALIC No. 2 \$2.25
ASPARAGUS WAS ORIGINALLY A WILD SEA COAST PLANT OF GREAT BRITAIN
The Common Name of one of its Species is Sparrow-Grass \$1234

25 A 40 a 10-POINT GOTHIC ITALIC No. 2 \$2.60
WE REMEMBER THAT HORRIBLE PATCH ON OUR TROUSERS
Though Forty Years Ago or More, It Haunts us Still \$2579

20 A 30 a 12-POINT GOTHIC ITALIC No. 2 \$2.55
ELEPHANTS CAN BE FOUND IN NEW YORK AND AFRICA
Elephas Sitieseum and Elephas Africanus

15 A 25 a 18-POINT GOTHIC ITALIC No. 2 \$3.80
LIFE'S REAL HEROES AND HEROINES ARE
Those who Suffer Silently and Alone 346

CURVED ANTIQUE.

10 A 15 a 18-POINT CURVED ANTIQUE \$3.40
SAN FRANCISCO THE AMERICAN GOLDEN GATE
Summer Sunrise on the Rockies in 1849

8 A 12 a 24-POINT CURVED ANTIQUE \$4.75
FANCY COSTUMES ON THE SANDS
Gambols of Seal Babies 1234

6 A 10 a 36-POINT CURVED ANTIQUE \$6.20
THE METROPOLITAN HOTEL
Barroom Luxuries 1234

4 A 6 a 48-POINT CURVED ANTIQUE \$7.25
Point Bodies REJUV!

NERO.

CAST FROM SOLID COPPER MATRIX. (PATENTED.)

4 A. \$2.35. 4 A. \$1.35.

36 POINT NERO.

5. \$1.90. \$5.60.

Manhattan Riding Academy
46 HORSEMEN 73

4 A. \$3.25.

48 POINT NERO.

6 A. \$2.30. \$5.55.

Modern - Galley - Slaves
6 RECORDS 3

3 A. \$3.50.

60 POINT NERO.

5 A. \$2.35. \$5.65.

Standard Machinery
2 UNIVERSE 4

3 A. \$4.15.

72 POINT NERO.

5 A. \$3.00. \$7.15.

Five WISE Men 5

MANHATTAN.

CANT FROM SOLID COPPER MATRIX. (PATENTED.)

10 A. \$1.50. 15 a. \$1.25.

GREAT PRIMER MANHATTAN.

\$2.75.

Artistically Arranged Theatrical and Operatic Stage Furniture
35 LIVINGSTONE SHAKESPEARE'S FALSTAF 74

8 A. \$2.00. 12 a. \$1.85.

DOUBLE PICA MANHATTAN.

\$3.85.

Attention! Thou Anarchial Political Agitators!
93 REVOLUTIONARY. 47

6 A. \$3.00. 10 a. \$2.15.

DOUBLE GREAT PRIMER MANHATTAN.

\$5.15.

Future Growth of Republican Cities
58 FALLEN FORTUNE 42

6 A. \$4.30. 10 a. \$3.60.

FOUR LINK PICA MANHATTAN.

\$7.90.

Modernized Custom-House
42 CANADIANS 79

5 A. \$4.95. 8 a. \$3.65.

FIVE ON FOUR LINE PICA MANHATTAN.

\$8.60.

Texas Silver Mines
78 HOUSTON 54

ITALIAN SHADED.

8 A 10-POINT ITALIAN SHADED \$2.30
OUR CASH BARGAINS
NEW STYLES 120

6 A 12-POINT ITALIAN SHADED \$3.00
AMERICANUS 12

4 A 18-POINT ITALIAN SHADED \$3.75
MARKETS 3

3 A 28-POINT ITALIAN SHADED \$4.25
DREAMS 5

3 A 36-POINT ITALIAN SHADED \$6.10
FROE 4

ALHAMBRA.

10 A 15 a 18-POINT ALHAMBRA \$2.50
THE WAY OF THE PRINTER IS HARD AND FULL OF TROUBLE
Do Something to Alleviate his Sufferings 1234567890

8 A 12 a 24-POINT ALHAMBRA \$4.10
THE BITTER FRUIT OF THE ALMOND TREE
South American Products 12345

6 A 10 a 36-POINT ALHAMBRA \$5.00
GO AMONG THE MOHAMMEDANS
And Learn Wisdom 1234

OLD STYLE ANTIQUE, NO. 2.

CAST FROM SOLID COPPER MATRIX.

24 A. 12 POINT OLD STYLE ANTIQUE.—F. \$2.85

THE SENTIMENTAL SONGSTER

20 A. 16 POINT OLD STYLE ANTIQUE. \$3.75

GOLD MINE CAMP

18 A. 20 POINT OLD STYLE ANTIQUE. \$4.50

CAREFUL PRINTING

12 A. 24 POINT OLD STYLE ANTIQUE. \$4.65

NEW STYLES

5 A. 36 POINT OLD STYLE ANTIQUE NO. 2. \$4.50

CAR STORIES

4 A. 40 POINT OLD STYLE ANTIQUE NO. 2. \$4.75

HEADING

3 A. 48 POINT OLD STYLE ANTIQUE NO. 2. \$5.50

MANSION

ANTIQUE CONDENSED, NO. 2.

CAST FROM SOLID COPPER MATRIX.

40 A, LONG PRIMER ANTIQUE CONDENSED No. 2. \$1.80
A REVISED HISTORY OF THE MODERN OLD-STYLES OF ARCHITECTURE
12345 FULLY ILLUSTRATED 67890

25 A, ENGLISH ANTIQUE CONDENSED No. 2. \$1.80
AESTHETIC SELECTIONS FROM THE OPERA OF DON JUAN
12345 BRILLIANT COSTUMES 67890

20 A, GREAT PRIMER ANTIQUE CONDENSED No. 2. \$1.80
PICTORIAL HISTORY OF GERMANY COMPOSERS
12345 MUSICIANS 67890

15 A, TWO LINES SMALL PICA ANTIQUE CONDENSED No. 2. \$2.40
BOSTON STOCK EXCHANGE REPORTS
12345 FINANCIERS 67890

12 A, TWO LINES PICA ANTIQUE CONDENSED No. 2. \$2.40
FOREIGN BUSINESS CORRESPONDENCE
23 TRANSACTIONS 67

10 A, TWO LINES ENGLISH ANTIQUE CONDENSED No. 2. \$2.25
CONNERS' TYPOGRAPHIC JOURNAL
45 FOUNDRY 98

10 A, TWO LINES GREAT PRIMER ANTIQUE CONDENSED No. 2. \$3.35
MECHANICS AND TRADERS

ANTIQUE CONDENSED, NO. 2.

CAST FROM SOLID COPPER MATRIX.

8 A.

TWO LINES PARAGON ANTIQUE CONDENSED NO. 2.

\$3.50

**PATENTED INVENTIONS
45 MACHINERY 67**

6 A.

MERIDIAN ANTIQUE CONDENSED NO. 2.

\$3.25

**DOMESTIC GOODS SALE
62 AUCTIONS 45**

6A.

FOUR LINES PICA ANTIQUE CONDENSED NO. 2.

\$4.75

THE CAT RAPIDS

6 A.

FIVE LINES PICA ANTIQUE CONDENSED NO. 2.

\$5.60

CONSTITUTIONAL

5 A.

SIX LINES PICA ANTIQUE CONDENSED NO. 2.

\$7.15

POINT TEAM

WAYSIDE.

EACH FONT COMPLETE WITH FIGURES AND ORNAMENTS.

25 A.

10 POINT WAYSIDE.

\$1.50

◀ ANOTHER GLASS AND STRONG TO DEADEN THIS PAIN ▶
▪ THEN ₪ ROGER ₪ AND ₪ I ₪ WILL ₪ START ▪

20 A.

12 POINT WAYSIDE.

\$1.60

I ▪ WONDER ▪ HAS ▪ HE ▪ SUCH ▪ A ▪ LUMPISH ▪ LEADEN
◀ ACHING THING IN PLACE OF A HEART ▶

20 A.

14 POINT WAYSIDE.

\$2.00

◀ WHY ▪ NOT ▪ REFORM ▪ THAT'S ▪ EASILY ▪ SAID ▶
◀ ALAS ₪ I ₪ AM ₪ PAST ₪ REFORM ▶

18 A.

16 POINT WAYSIDE.

\$2.05

IS THERE A WAY TO FORGET TO THINK
◀ HOME ₪ FORTUNE ₪ FRIENDS ▶

15 A.

18 POINT WAYSIDE.

\$2.55

◀ THE ₪ SAME ₪ OLD ₪ STORY ▶
◀ YOU KNOW ▶

10 A.

24 POINT WAYSIDE.

\$3.00

◀ A WAYSIDE REVERIE ▶
◀ ROGER ▪ AND ▪ YOU ▶

WAYSIDE.

EACH FONT COMPLETE WITH FIGURES AND ORNAMENTS.

10 A. 28 POINT WAYSIDE. \$4.00
STRIKE FOR TRUTH
AND HONOR

10 A. 30 POINT WAYSIDE. \$4.75
SAN FRANCISCO
NUMBER

8 A. 36 POINT WAYSIDE. \$5.00
GOLDEN GATE
RACES

6 A. 40 POINT WAYSIDE. \$5.25
STUPENDOUS

4 A. 48 POINT WAYSIDE. \$5.50
MORPHEUS

METROPOLIS.

CAST FROM SOLID COPPER MATRIX. (PATENTED.)

20 A, \$1.00. 20 A, \$.45. 6 POINT METROPOLIS. 75 a, \$1.50. \$2.95.

Our Specimen Book of Electrotype Business Cuts, Ornaments, Corners, Initials, Etc.,

1234 FOR RECOGNIZED PRINTERS AND PUBLISHERS ONLY. 5678

Is Not Equaled by Any Other Type and Electrotype Foundry in the United States. Send for it

BENJAMIN FRANKLIN CENTENNIAL TYPOGRAPHIC CONVENTION

20 A, \$1.35. 20 A, \$.45. 8 POINT METROPOLIS. 70 a, \$1.00. \$3.70.

This Neat and Attractive Series is Meeting with Universal

Approval among Job and Book Men, and we Predict for it an Immense Sale

SOLD IN FIFTY POUND FONTS AT ROMAN PRICE.

ALL COMPLETE WITH POINTS AND FIGURES.

15 A, \$1.15. 15 A, \$.45. 10 POINT METROPOLIS. 50 a, \$1.25. \$2.85.

Specimen Books are Supplied to all Job Printers in the

United States, Canada, Mexico, South America, Australia, China,

EUROPE, ASIA, AFRICA, NEW JERSEY.

84 NEWSPAPER 26 PUBLISHERS 70

15 A, \$1.50. 15 A, \$.70. 12 POINT METROPOLIS. 40 a, \$1.70. \$3.90.

Conners' Brass Rule Specimens on Application

The Finest Assortment Manufactured in the Country

THE TYPOGRAPHIC MESSENGER

ISSUED EVERY THREE MONTHS

10 A, \$1.90. 18 POINT METROPOLIS. 25 a, \$2.00. \$3.90.

Ancient Egyptian Monoliths

Readings, Recitations and Dialogues

68 JAMES CONNER 23

6, 8, 10 AND 12 POINT METROPOLIS SOLD AT ROMAN PRICES IN FONTS OF 50 POUNDS.

METROPOLIS.

CAST FROM SOLID COPPER MATRIX. (PATENTED.)

8 A, \$2.25.

24 POINT METROPOLIS.

15 a, \$2.00.

\$4.30.

New Autumn Styles
Metropolitan 4 Institutions
PROTECTIONIST

6 A, \$3.70.

36 POINT METROPOLIS.

10 a, \$3.00.

\$6.70.

Deacon Bishop
Union Hills Church
4 TRUNK 5

4 A, \$4.20.

48 POINT METROPOLIS.

6 a, \$3.20.

\$7.40.

Horse 2 Races
POSTERS

3 A, \$5.20.

60 POINT METROPOLIS.

NUMBER

MAYFLOWER.

CAST FROM SOLID COPPER MATRIX. (PATENTED.)

20 A. 12 POINT MAYFLOWER. \$2.15

86TH MAGNIFICENT ORIENTAL PAGEANT
QUAINT POEMS OF ANCIENT GODS OF MYTHOLOGY
MOTHER GOOSE FABLES

15 A. 18 POINT MAYFLOWER. \$2.75

∴ GALLANT 69TH REGIMENT ∴
HUMBLE COTTAGE MERRIE DANCERS
23 PROGRAMME 50

10 A. 24 POINT MAYFLOWER. \$3.15

PISCATORIAL ∴ WANDERINGS
BARREN DESERTS

6 A. 36 POINT MAYFLOWER. \$4.10

6 WANDERING 8
MORNING RAMBLES

4 A. 48 POINT MAYFLOWER. \$4.70

FOAM 8 BOAT

OLD STYLE ATHENIAN EXTENDED

CAST FROM SOLID COPPER MATRICES.

PATENTED.

15A 10A 30a.

6 POINT OLD STYLE ATHENIAN EXTENDED.

\$3.05

CONSTITUTIONAL JURISPRUDENCE

New By-Laws, Rules and Mandatory Regulations

CALIFORNIAN GOVERNMENT

15A 10A 25a.

8 POINT OLD STYLE ATHENIAN EXTENDED.

\$3.40

THE SOUTH-WEST EAGLE

Enterprising North-Western Journalists

GRAND GOLDEN GATES

10A 10A 30a.

10 POINT OLD STYLE ATHENIAN EXTENDED.

\$3.35

CELEBRATED ACTORS

Bright Little Juvenile Comedies

ELEGANT PROGRAM

Beautiful Easter Novelties

ENTERTAINMENT

8A 8A 15a.

12 POINT OLD STYLE ATHENIAN EXTENDED.

\$4.00

SACRED HISTORY

Ruined Egyptian Temples

ANCIENT ATHENS

6A 6A 12a.

18 POINT OLD STYLE ATHENIAN EXTENDED.

\$4.80

EXPEDITIONS

The Mining Regions

SACRAMENTO

ATHENIAN.

CAST FROM SOLID COPPER MATRICES. ORIGINAL.

PATENTED.

25A 15A 30s, 6 POINT ATHENIAN. \$3.75	25 A 15 A 30 s, 8 POINT ATHENIAN. \$4.70
THE AMERICAN PEOPLE	BORDER ARMY LIFE
Physical Architecture of Thermal Laws	Description of the Indian Nomads
125 ENGRAVINGS 890	12 PHILADELPHIA 48

20 A 15 A 25 s, 10 POINT ATHENIAN. \$5.20
BALL COSTUMES AND ORNAMENTS
Elegant Examples of the Costumes amongst all Nations
15 EXECUTED IN FINE STYLE 89

15 A 15 A 20 s, 12 POINT ATHENIAN. \$5.50
RECITATIONS AND READINGS
Eloquent, Patriotic, Humorous and Sentimental
15 ADAPTED FOR ARTISTS 23

10 A 10 A 15 s, 18 POINT ATHENIAN. \$5.95
FASCINATING READABLE
Selections from the Current Belles-Lettres
14 ENGLISH AUTHORS 56

8 A 8 A 12 s, 22 POINT ATHENIAN. \$7.30
COLLEGE SERIES
School PEDAGOGISM Histories

CAPS, 5 A, \$1.05. 18 POINT ATHENIAN ORNATE. SMALL CAPS, 8 A, \$1.05

MASSACHUSETTS BUILDING AND LOAN ASSOCIATION \$23

CAPS, 4 A, \$1.50. 22 POINT ATHENIAN ORNATE. SMALL CAPS, 6 A, \$1.30

UNITED STATES INSURANCE CO 250

CONDENSED ATHENIAN.

CAST FROM SOLID COPPER MATRICES.

PATENTED.

- | | | |
|---|------------------------------|--------|
| 30 A 50 s, | 6 POINT CONDENSED ATHENIAN. | \$2.75 |
| A TIGHT SQUEEZE; OR, THE ADVENTURES OF A PAIR OF THE FIRST FEMALE CORSETS | | |
| Facts Relative to the Death of Seven Young Maidens On a Stupid Tramp from New York to Mexico for Shoe-Leather Complexions. 8906 | | |
| Thomas Allen, Rowing Press Printer, at Palladio's Head, Middle-Row, Holborn, | | |
| 30 A 20 A 50 s, | 8 POINT CONDENSED ATHENIAN. | \$4.50 |
| THREE LITTLE MOTHERLESS CHILDREN CHICKENS AND THEIR MEANDERINGS | | |
| Search for Honey-Combs and Garden Worms in the Under-Brushes of Cantankerous South Carolina | | |
| 12 MYSTERIOUS ROBBERY OF THE VALUABLE BROKEN Egg. 34 | | |
| 25 A 15 A 40 s, | 10 POINT CONDENSED ATHENIAN. | \$4.65 |
| ATTENTION TO THE RELIEF OF GREEN CUCUMBER EATERS | | |
| Thoughtful and Intelligent Hospital Stomach Pump Company. Brilliant and Unique | | |
| 234 DEVELOPMENT OF GRIPING VEGETABLES 567 | | |
| 10 A 10 A 20 s, | 12 POINT CONDENSED ATHENIAN. | \$3.50 |
| THE COMMANDING AMERICAN LITERATURE | | |
| Independent and Original Birch Applications by the Million | | |
| 34 FOOTSTEPS OF THE DANCING MASTER 58 | | |
| 8 A 8 A 15 s, | 18 POINT CONDENSED ATHENIAN. | \$4.50 |
| Themes for Slovenly Blackmailing Slanderers | | |
| 26 COMPILED ABROAD AT HOME 34 | | |
| 6 A 6 A 10 s, | 24 POINT CONDENSED ATHENIAN. | \$5.85 |
| The Baby Window Finger-Marks | | |
| 12 GROTESQUE EXAMPLES 32 | | |
| 4 A 4 A 8 s, | 36 POINT CONDENSED ATHENIAN. | \$7.00 |
| Maine Crank Manufacture | | |
| ELEGANT 3 BRILLIANT | | |

GALLICAN.

CAST FROM SOLID COPPER MATRICES. ORIGINAL.

- 30 A 30 A 40 s, 6 POINT GALLICAN No. 2. \$3.00
A Complete Handbook for Travellers in Europe and America
18 MARCHES THROUGH PALESTINE 70
Revised and Only Authoritative Edition of Captain Mike Cleary's Practical City Politician
EGYPTIAN MONUMENTAL INSCRIPTIONS
- 25 A 25 A 40 s, 8 POINT GALLICAN No. 2. \$3.40
Great Railroad Construction in the United States
18 SCIENTIFIC ENGINEERING 72
Scientific Foot-Bridge Engineering on a Ponderous Centrifugal Scale
EARTH WORKS AND VIADUCTS
- 20 A 20 A 40 s, 9 POINT GALLICAN No. 2. \$3.50
Ferns and Flowers of Central America
17 ILLUSTRATED 68
Gorgeous Summer Foliage of Our Southern Countries
RECENT PUBLICATIONS
- 20 A 20 A 30 s, 10 POINT GALLICAN No. 2. \$4.10
Prominent American School Book
18 BOSTON 36
Prominent Californian Educational Publications
HOUSEHOLD EDITION
- 15 A 15 A 20 s, 12 POINT GALLICAN No. 2. \$4.55
Handsomest Formations
3 PERFECTION 5
Symmetrical English Architecture
576 FORTIFICATIONS 948

GALLICAN.

— CAST FROM SOLID COPPER MATRICES. —

10 A 10 A 15 A.

18 POINT GALLICAN No. 2.

\$5.30

Printers' ART Novelties
AUCTION SALES
Merchants Mechanics
EXPORT IMPORT

6 A 6 A 10 A.

24 POINT GALLICAN No. 2.

\$5.85

MODERN BRIDGES
Cloudless Structures
SUNBEAM 5

5 A 5 A.

28 POINT GALLICAN.

\$4.40

PINE FORESTS
2 LUMBER 3

5 A.

36 POINT GALLICAN.

ORIGINAL.

\$3.75

SIRE 26 SIGH

4 A.

40 POINT GALLICAN.

ORIGINAL.

\$4.60

HUD 8 SON

LIGHTFACE CELTIC.

- 30 A 40 s, 6 POINT LIGHT FACE CELTIC. \$4.25
Portraits of Distinguished Female Sovereigns Drawn
Crowned Heads of England, Germany, Austria, Russia, Portugal and Denmark
284 BY MOST EMINENT ARTISTS 567
- 30 A 40 s, 8 POINT LIGHT FACE CELTIC. \$5.50
Dictionary of Agricultural Technical Terms
Heaving the Log, Pying a Form, Political Pull, Manning a Hose
123 FARMER'S COMPANION 486
- 20 A 30 s, 10 POINT LIGHT FACE CELTIC. \$4.85
Men of Letters and Men of Science
The College Educators of America's Rising Generation
23 WITH ILLUSTRATIONS 45
- 20 A 25 s, 12 POINT LIGHT FACE CELTIC. \$5.50
The Great South-Western Prairies
Cattle Ranches of Texas, New Mexico and Utah
12 INDIAN EXPEDITION 15
- 10 A 15 s, 18 POINT LIGHT FACE CELTIC. \$5.80
Rules and Regulations
Californian \$54.25 Constitution
89 PRACTICAL 73
- 8 A 12 s, 22 POINT LIGHT FACE CELTIC. \$7.00
London £2 Bridges
European Tourist Guide
54 SCOTLAND 37
-

INCLINED ANTIQUE.

PATENTED.

30 A 50 s, 6 POINT INCLINED ANTIQUE. \$2.75

*Memoirs of the Lives and Works of Celebrated European Sculptors,
Painters, Engravers and Architects, Compiled in Book Form by American Writers
Historical and Descriptive Accounts*
123 BIOGRAPHICAL ART REMINISCENCES 456

30 A 50 s, 8 POINT INCLINED ANTIQUE. \$3.15

*America, Belgium, England, Scotland, Ireland, France,
Northern and Southern Germany, Argentine Republic, Austria, Rome,
Russia, Prussia, Australia and Italy*
15 TOURISTS' ILLUSTRATED GUIDE-BOOK. 67

25 A 40 s, 10 POINT INCLINED ANTIQUE. \$3.35

*Memorial Poems of Alice and Phebe Cary
Coleridge's Christabel, and other Imaginative Poems
European Tourist Guide*
18 AMERICAN LITERATURE 73

20 A 30 s, 12 POINT INCLINED ANTIQUE. \$3.50

*New York Legislature Enactments
Assets and Liabilities of Foreign Companies
Fire Insurance Risks*
23 INSURANCE COMPANY 45

LATIN ITALIC.

CAST FROM SOLID COPPER MATRICES.

- 30 A 50 a, 6 POINT LATIN ITALIC. \$2.35
The origin of Serpent-worship is to be sought for in the Constitution of the Human Mind, and not in any invented system of religion or superstition. It has relation to the Sexual system of Nature, which is typified in the Ancient Mythologies under various
SERPENT - WORSHIP AMONG THE PRIMITIVE RACES ' 1876
but this was also worshiped in Egypt,
- 30 A 50 a, 8 POINT LATIN ITALIC. \$2.50
It is needless to inform the majority of our Readers that the greatest of Real Authors—the most Profound Thinkers—are those who cared least for Notoriety or Fame. The most justly renowned
EDUCATION AND BELLES-LETTRES 1234
- 25 A 40 a, 10 POINT LATIN ITALIC. \$2.40
The actual practical Measure of Value, is the average Money-price of the Article in question, at the given time and place; and it is the average, because the Money-market,
PRODUCTIVE AGENCY 576
- 20 A 30 a, 12 POINT LATIN ITALIC. \$2.65
Wealth is a Relative Term, for as there is Property of only a certain Amount in a Country, so the possession of a Large Share
90 REVENUE EXPENDITURE 78
- 15 A 20 a, 18 POINT LATIN ITALIC. \$3.15
The American Army at Cambridge Two Months and no Blow had been struck to Country of the British Troops
18 UNITED STATES. 75
- 10 A 15 a, 22 POINT LATIN ITALIC. \$3.25
Curved composition is Handsome Attractive in proportion to its elegant
57 FORM IMPOSITION 18

LATIN COMPRESSED

CAST FROM SOLID COPPER MATRICES.

20 A 30 a, 12 POINT LATIN COMPRESSED \$2.25
Relative Discussions as to Specimens Quarried for Practical Scientific Examination
12345 SCIENTIFIC MINERALOGICAL RESEARCHES 67890

15 A 20 a, 18 POINT LATIN COMPRESSED \$2.95
Professional Medical Doctors Under Oratorical Discussion
89 OPERATIVE SURGICAL REVIEW 76

10 A 15 a, 24 POINT LATIN COMPRESSED \$3.40
Discoveries in Eastern Palestine and Jerusalem
34 HISTORICALLY COMPOSED 25

8 A 12 a, 36 POINT LATIN COMPRESSED \$4.55
Wonderful Success of Searchers Pursued
6 AUSTRIAN TRAVELLERS 2

8 A 12 a, 40 POINT LATIN COMPRESSED \$5.00
Arithmetical Questions Meditated
45 MATHEMATICS 78

6 A 10 a, 48 POINT LATIN COMPRESSED \$6.15
Combined PUSHED Powerful

LIGHTFACE RUNIC.

CAST FROM SOLID COPPER MATRICES.

25 A 40 s. 10 POINT LIGHTFACE RUNIC. \$3.90

Celebrated New York Musical, Theatrical and Literary Academies
A New Manual of English Pronunciation and Spelling for Higher Lessons
13 COLLEGIATE AND POLYTECHNIC 68

20 A 30 s. 12 POINT LIGHTFACE RUNIC. \$4.35

Handsome Souvenirs Every 100 Performances
First-Class Dramas, Comedies, Farces and Humorous Dialogues
69 MAYO DRAMATIC ASSOCIATION 16

15 A 25 s. 14 POINT LIGHTFACE RUNIC. \$4.75

Home, School and Public Readings
Whoever Envies Another Confesses His Superiority
8 COLUMBIAN SPEAKER 69

12 A 20 s. 18 POINT LIGHTFACE RUNIC. \$5.35

Popular Education in England
Life and Doings of Australian Bushmen
5 LETTER FROM EUROPE 3

10 A 15 s. 22 POINT LIGHTFACE RUNIC. \$5.85

The Science of Astronomy
Upton National Military Tactics
12 MOON ECLIPSE 78

LIGHTFACE RUNIC.

CAST FROM SOLID COPPER MATRICES.

6 A 10 s.

28 POINT LIGHTFACE RUNIC.

\$5.90

Sketches of Bonarroti
Spiritualistic Amativeness
ROYAL ACADEMY

5 A 8 s.

40 POINT LIGHTFACE RUNIC.

\$7.25

Manhattan Bank
Dime Saving Institute
18 UNITED 79

4 A 6 s.

48 POINT LIGHTFACE RUNIC.

\$8.40

Grand Rat Picnic
3 MEMBER 5

3 A 5 s.

60 POINT LIGHTFACE RUNIC.

\$9.45

One SIR Ned

LATIN SERIES.

COPYRIGHTED.

15 A 25 a.

18 POINT LATIN.

\$3.90

Celebrated and Eminent Lawyers
Abraham was Seventy-seven Years Old
SOCIETY 83 MANUAL

10 A 15 a.

22 POINT LATIN.

\$3.00

Recent Morocco Uprising
Artists' Second Annual Convention
3 MACKINTOSH 7

10 A 15 a.

28 POINT LATIN.

\$5.40

Principles of Chemistry
Complete History of France
NEW 59 IDEA

8 A 12 a.

36 POINT LATIN.

\$6.70

Christmas Presents
Four Thousand Guineas
4 BUFFALO 9

CLARENDON EXTRA CONDENSED.

CAST FROM SOLID COPPER MATRICES.

15 A 25 s.

18 POINT CLARENDON EXTRA CONDENSED.

\$2.70

POETS NOVELISTS WITS HUMORISTS ETC

Interesting Reminiscences and Sketches of American Society

12 The East and West 38

10 A 15 s.

24 POINT CLARENDON EXTRA CONDENSED.

\$3.35

KINGS AND QUEENS OF FRANCE

Legend, Romance and History of Heroism

16 Reign of the Dynasty 75

8 A 12 s.

36 POINT CLARENDON EXTRA CONDENSED.

\$4.50

GARLANDS OF FLOWERS

Grown in most Classic Localities

6 A 8 s.

48 POINT CLARENDON EXTRA CONDENSED.

\$5.50

MERCHANT MARINE

Instructive Entertaining 71

4 A 6 s.

60 POINT CLARENDON EXTRA CONDENSED.

\$6.55

Collect PORT Paint 3

CLARENDON.

SOLID COPPER MATRICES.

- 30 A 50 a, 5 POINT CLARENDON ON 6 POINT BODY. \$2.10
Sad Termination of the Poetic Moonless Rambles of Deacon Smith
Soul Inspiring Glances of a Tall, Gaunt, Freckle Faced Maiden of Doubtful Age and Questionable Antecedents
26 THE CHAMBERMAID'S ROMANTIC KLOPFMENT 79
- 30 A 50 a, 6 POINT CLARENDON. \$2.30
Practical Recipes for Manufacturing Pickles, Puddings and
The Manner of Compounding the Various Well Known Brands of American Homemade Happiness
45 MATTER TO BE KEPT STANDING 23
- 30 A 50 a, 7 POINT CLARENDON. \$2.50
Choice Mouldy Volumes for Antiquated Old Humanity
Celebrated Rare and Dusty Libraries, Gathered from All Quarters of the Earth's Surface
34 SCANDALOUS BOOKWORM DEPRAVITY 75
- 30 A 50 a, 8 POINT CLARENDON. \$2.80
Pleasant Americanized Methodical Pedestrianism
59 Complicated Experiences of a Roving Disciple of Faust and Guttenberg 34
MISCELLANEOUS AMUSEMENTS
- 30 A 50 a, 9 POINT CLARENDON. \$2.85
Dakota and Montana Indian Campaigns of General Custer
The Great Western Plains and their 4689 Unromantic Red men Inhabitants
LIFE AMONG THE DUSKY SQUAWS
- 25 A 40 a, 10 POINT CLARENDON. \$3.10
Pure Unwashed Mongolian Literature
Hideous Heathen Orgies. Grand Annual Opium Carnival
78 CHINESE LAUNDRY POEM 64
- 15 A 25 a, 12 POINT CLARENDON, No. 2. \$3.00
Pleasant Household Remedies
The Old Reliable Domestic Country Physician
3 GREATGRANDMOTHER 6

CLARENDON.

SOLID COPPER MATRICES.

15 A 25 s.

18 POINT CLARENDON.

\$3.85

Slender Smooth-faced Lunatics
Harmless Imbeciles 23 Raving Maniacs
3 CRUSHED DUDEISM 4

10 A 20 s.

22 POINT CLARENDON, No. 2.

\$3.80

Puritanical 84 Provinces
Sabbath Strolls in New Brunswick
POOL EXERCISES

8 A 15 s.

28 POINT CLARENDON.

\$5.20

Skullcracked 96 Philosophers
SOAP BUBBLES

5 A 8 s.

40 POINT CLARENDON.

ORIGINAL.

\$5.00

Latest Novel Series
3 MODERN 4

4 A 5 s.

48 POINT CLARENDON, No. 2.

ORIGINAL.

\$7.50

Real Irish Lace
2 POINT 8

CLARENDON COMPRESSED.

CAST FROM SOLID COPPER MATRICES.

- 30 A 20 A 50 a, 6 POINT CLARENDON COMPRESSED. \$2.35
RARE ANCIENT KICKAPOO KICKERS MANUSCRIPT COLLECTION CONVENTION
The Democratic, Greenback Merchants, Manufacturers and Bankers and National Commercial Labor-Saving Club
58 PROPORTIONABLE POETRY PROMISCUOUSNESS 78
- 30 A 20 A 50 a, 8 POINT CLARENDON COMPRESSED. \$2.70
PATENT OFFICE RECORDS FOR 1887 DISSEMBLING ROMEOS
Acute Remorseless Loveless Rambles Remembered Valuable New Books for Public Libraries
34 THE AMOROUS ADONIS QUILTING BEES 56
- 25 A 15 A 40 a, 10 POINT CLARENDON COMPRESSED. \$3.05
BLOWING OUT THE MUSICAL ASSOCIATION CANDLE FUND
The Mellifluous Arts and Sciences among the Ancient Melodious Egyptians
45 QUARTERLY NIGHTINGALE SONGS 62
- 15 A 10 A 25 a, 12 POINT CLARENDON COMPRESSED. \$2.55
LONG BRANCH SUMMER SEASIDE MURMURINGS
A Treatise on the Quiet Coolest Summer Retreats
\$8,754 BALTIMOREANS £8.14.6
- 15 A 25 a, 18 POINT CLARENDON COMPRESSED. \$3.45
Poetical Examination Committees
Association for the Advancement of Sciences
12 ENGLISH LANGUAGE 13
- 10 A 20 a, 22 POINT CLARENDON COMPRESSED. \$3.55
Interesting Moorish Architecture
Eighth Century French Society Sketches
13 ORIGINAL MOSQUES 14

CLARENDON COMPRESSED.

CAST FROM SOLID COPPER MATRICES.

8 A 15 a.

26 POINT CLARENDON COMPRESSED.

\$4.25

Special and Attractive Sale
Paracentesis of the Pericardium
54 INSTRUMENTS 67

8 A 15 a.

36 POINT CLARENDON COMPRESSED.

\$6.05

Attractive Milliners
American Bonnet Democrat
5 REFERENCE 7

8 A 12 a.

40 POINT CLARENDON COMPRESSED.

\$8.10

Washington's Letters
28 NATIONAL 65

6 A 10 a.

48 POINT CLARENDON COMPRESSED.

\$9.25

New York Journal
65 PRESS 14

CALEDONIAN.

40 A 75 a, 5 POINT CALEDONIAN. \$4.30

A practice of introducing Ornaments, Drawings, Emblematic Figures and even Portraits into Manuscripts, is of great antiquity. Varro wrote the lives of seven hundred illustrious Romans, which he enriched with their Portraits, as Pliny attests in his Pomponius Natural History.

1234 ANCIENT ILLUMINATED MANUSCRIPTS 5678

30 A 50 a, 6 POINT CALEDONIAN. \$2.90

Printers are sometimes asked why various kinds of Papers obtained the peculiar names they bear. Here is the reason: In ancient times when comparatively few people could read.

1234 NAMES OF PRINTING PAPER 5678

30 A 50 a, 8 POINT CALEDONIAN. \$3.15

Few Articles are of more General Use, or more important, in the Economy of Human Life, than Paper. As Medium for Recording and Preserving the Achievements

239 HISTORY OF PAPER MAKING 468

25 A 40 a, 10 POINT CALEDONIAN. \$3.35

Punctuation is the Art of dividing written composition into sentences, or parts of sentences by points or stops, in order to make

123 ART OF PUNCTUATION 456

20 A 30 a, 12 POINT CALEDONIAN. \$3.50

It is hardly necessary to call the attention of an ordinary observer to the Large Amount of Printing

123 FOUNDERS 456

15 A 25 a, 18 POINT CALEDONIAN. \$4.95

The first Writers suffered their Orthography to Deteriorate. Pictorials.

123 BOOK STORE. 456

CALEDONIAN.

10 A 20 s.

22 POINT CALEDONIAN.

\$5.30

The Greek Letters
Mister Makepeace Thackery
12 MAGENTA 56

6 A 12 s.

28 POINT CALEDONIAN.

\$5.10

Poetry Instruction
Art and Science in Verse
2 PRINTER 8

6 A 12 s.

36 POINT CALEDONIAN.

\$7.55

Origin of the Press
8 HERALD 6

5 A 8 s.

40 POINT CALEDONIAN.—ORIGINAL.

\$7.00

Words Letters 5
COMMON

4 A 6 s.

48 POINT CALEDONIAN.—ORIGINAL.

\$8.90

Note 25 Read
AMERICA

CLARENDON LIGHTFACE.

CAST FROM SOLID COPPER MATRICES.

-
- 30 A 50 a, 5 ON 6 POINT CLARENDON LIGHTFACE. \$2.25
Standard Systematical Description and Explanation of Some Appellative Terms
78 HISTORY AND POETRY 45
Interesting Detailed Account of the First Session of the United States Congress, held in the Commonwealth of Boston
57 GEOGRAPHICAL AND HISTORICAL ILLUSTRATIONS 24
- 30 A 50 a, 6 POINT CLARENDON LIGHTFACE. \$2.25
Memoirs and Miscellaneous Matters Relating to Their Arts Explained
34 OUR FELLOW CRAFTSMEN 25
The Imperfections and Unreliability of Electro Matrices as Used by Certain Disreputable Type Makers
123 DISTINGUISHED AMERICAN MECHANICS 789
- 25 A 40 a, 8 POINT CLARENDON LIGHTFACE. \$2.70
Enthusiastic Admiration of Courteous Hesitating Cavaliers
Amorous Meetings in Central Park Quiet Lanes and Sequestered Shady Nooks
345 NINETEEN BEAUTIFUL MAIDENS 678
- 30 A 50 a, 9 POINT CLARENDON LIGHTFACE. \$2.85
Adventures of Ambitious Kangaroo Hunters
Fabulous Stories of Life in the Jungles of South Australia and East India
23 TRAVELLING IN AUSTRALASIA 45
- 30 A 40 a, 10 POINT CLARENDON LIGHTFACE. \$2.80
Practical Definitions and Clearer School Rules
The Public School Education of Our Rising American Generation
98 COMMERCIAL ARITHMETIC 17
- 20 A 30 a, 12 POINT CLARENDON LIGHTFACE. \$2.80
Humorous Mechanical Theatre Executions
A Solemn Satire by the Only Original Mulcahey Minstrels
719 COMICAL CARICATURES 239
-

DORIC SHADED.

PATENT APPLIED FOR.

8 A 12 a,

18 POINT DORIC SHADED.

\$5.00

Condition of Germany
CUSTOM LEGEND
Social Political Commercial
16 HABITS 47

6 A 10 a,

24 POINT DORIC SHADED.

\$6.50

Entertainment
Elevating Instructive
MAGAZINE

5 A 8 a,

36 POINT DORIC SHADED.

\$9.00

Latin Orator
School Manuals
3 JUNIOR 8

DORIC SERIES.

CAST FROM ORIGINAL MATRICES

40 A 50 s, 6 POINT DORIC. \$3.45
THE NORTH AMERICAN HOME GARDENS
Principles and Rules for the Cultivation of Fine Fruits and Vegetables
12 Flowers and Shrubbery 45

40 A 50 s, 8 POINT DORIC. \$4.75
BROOKLYN BUSINESS DIRECTORY
Manufacturers, Tradesmen, Professionals, Amateurs,
12 The Farm Record 45

20 A 30 s, 12 POINT DORIC. \$4.00
WILD ADVENTURERS
America, Europe, Australasia, Africa,
812 Asia 367

15 A 20 s, 16 POINT DORIC. \$4.30
BIOGRAPHICAL
Union of the Country People
17 April 75

10 A 15 s, 20 POINT DORIC. \$5.45
HAND-BOOKS
Towns, Cities and Places
of Interest 6

DORIC SERIES.

CAST FROM ORIGINAL MATRICES.

8 A 12 s.

36 POINT DORIC.

\$8.05

MEMORIALS
Fort of Ticonderoga
7 Capture 5

5 A 8 s.

40 POINT DORIC.

\$7.50

LEXINGTON
United 75 States
Magazine

4 A 6 s.

48 POINT DORIC.

\$8.00

CONCORD
Brook 8 Farm
Meadow

GOTHIC NUMBER FOUR.

CAST FROM SOLID COPPER MATRICES.

-
- 50 A 75 s, 5 ON 6 POINT GOTHIC No. 4. \$4.80
Learning, if deep, if useful and refined, Communicates its polish to the Mind
Numerous Unfounded Remarks as to Professor Pedagogue A. Periwinkle's Horrible Midnight Hallucinations
35 INTRODUCTION TO GREEK PROSE COMPOSITION 67
- 30 A 50 s, 6 POINT GOTHIC No. 4. \$2.60
Expedition of Captain Clarke across the Rocky Mountains and
Through the Bad Lands of Idaho and Washington Ter., to the Mouth of the Columbia River
423 PRINTERS' FURNISHING WAREHOUSE 758
- 30 A 40 s, 8 POINT GOTHIC No. 4. \$2.95
Notes of a Tour among the Indian Tribes of Chili
Beautiful Rainbow Plumage of The South American Tropical Birds
\$75 RENWICK'S LIFE OF CLINTON \$32
- 20 A 30 s, 10 POINT GOTHIC No. 4. \$2.80
Society for the Advancement of Science
Polytechnic Associations of the English-French Republicans
18 ACCEPTED MASONS 63
- 20 A 30 s, 12 POINT GOTHIC No. 4. \$3.15
New style of Photographic Albums
Published from the Advance Sheets of the Authors
26 NOVEL TROUBLES 68
- 12 A 25 s, 18 POINT GOTHIC No. 4. \$4.80
Fall and Winter Opening
Gentlemen's Dress Goods Stock
38 OIL PAINTING 86
-

N. C. HAWKS, SAN FRANCISCO.

GOTHIC NUMBER FOUR.

8 A 15 a,

24 POINT GOTHIC No. 4.

\$5.90

**American Fine Arts
United Historical States
6 REUNION 3**

4 A 10 a,

36 POINT GOTHIC No. 13.

\$6.10

**United States Court
5 GEORGIA 4**

4 A 6 a,

40 POINT GOTHIC No. 13.

\$6.35

**English, Scotch,
8 GERMAN 6**

4 A 6 a,

48 POINT GOTHIC No. 13.

\$9.85

**Decided Ruin
MURDER**

GOTHIC CONDENSED No. 4.

CAST FROM SOLID COPPER MATRICES.

-
- | | | |
|---|----------------------------------|--------|
| 20 A 50 a, | 6 POINT GOTHIC CONDENSED No. 4. | \$2.00 |
| Account of Visits to the Malay and Lee-Choo Islands and Coast of China by Com. Barry | | |
| The Agricultural and Manufacturing Resources of the Enterprising Republics of South America cannot be Surpassed | | |
| 67 PACIFIC SURVEYING AND EXPLORING EXPEDITION 18 | | |
| 30 A 50 a, | 8 POINT GOTHIC CONDENSED No. 4. | \$2.20 |
| Valuable Collection of American Anecdotes, Original and Selected from Best Authors | | |
| History of the Discovery and Settlement of the Beautiful Valley of the Mississippi by Daniel De Soto | | |
| 868 TYPE FOUNDRY AND PRINTERS' WAREHOUSE 123 | | |
| 25 A 40 a, | 10 POINT GOTHIC CONDENSED No. 4. | \$2.40 |
| Lights and Shadows of New York Picture Galleries as seen from "L" Trains | | |
| 79 LEGENDS OF THE MONASTIC ORDERS 40 | | |
| 20 A 30 a, | 12 POINT GOTHIC CONDENSED No. 4. | \$2.45 |
| The Cultivation and Progress of Agriculture in the United States | | |
| 3 TREATISE ON MATHEMATICAL SUBJECTS 2 | | |
| 20 A 30 a, | 14 POINT GOTHIC CONDENSED No. 4. | \$2.95 |
| Prize Collection of the Most Notable Beauties in the World | | |
| EVERYDAY HAPPENINGS IN LIFE | | |
| 15 A 25 a, | 18 POINT GOTHIC CONDENSED No. 4. | \$3.15 |
| Essays on the Powers of Intellectual Assemblymen | | |
| WEBSTER'S POPULAR DICTIONARY | | |
| 12 A 20 a, | 22 POINT GOTHIC CONDENSED No. 4. | \$3.45 |
| Handsome Collection of Ancient Souvenirs | | |
| 937 CONSTITUTIONAL 253 | | |
| 10 A 15 a, | 26 POINT GOTHIC CONDENSED No. 4. | \$4.20 |
| Typographic CONNER'S Messenger | | |
| 8 A 12 a, | 40 POINT GOTHIC CONDENSED No. 4. | \$6.35 |
| National PACIFIC Company | | |
-

ANTIQUÉ POINTED.

CAST FROM SOLID COPPER MATRICES.

15 A 20 a,

12 POINT ANTIQUÉ POINTED.

\$3.30

CRITICAL ESSAYISTS

Free Lances in the Political Fields
95 Fierce Debate 87

10 A 15 a,

18 POINT ANTIQUÉ POINTED.

\$4.25

HISTORICAL SCENE

Fifteen Standard Volumes
43 Publisher 25

8 A 12 a,

22 POINT ANTIQUÉ POINTED.

\$4.30

FINE MUSIC

Curious Colored Crank 5

6 A 10 a,

28 POINT ANTIQUÉ POINTED.

\$5.60

CHINAMEN

Central Pacific Road 1

5 A 8 a,

40 POINT ANTIQUÉ POINTED.

\$6.65

Cents PEN Diver

4 A 6 a,

48 POINT ANTIQUÉ POINTED.

\$9.40

Dress Means

GOthic CONDENSED No. 6.

— CAST FROM SOLID COPPER MATRICES. ORIGINAL. —

25 A 20 A 40 a, 10 POINT GOTHIC CONDENSED No. 6. \$2.40

RELIABLE COMPANION OF AMERICAN FARMERS AND GARDENERS

Practical Directions and Hints for the Better Management of the Farm and Household

25 CATTLE RANCHES IN THE SOUTHWEST 63

20 A 12 A 30 a, 12 POINT GOTHIC CONDENSED No. 6. \$2.50

INCLUSIVE UNITED STATES BIBLIOPOLIST

Unique Literary Register and Repository of Promissory Notes and Queries

12 IMPORTANT AND VALUABLE 57

15 A 10 A 25 a, 18 POINT GOTHIC CONDENSED No. 6. \$2.85

MODERN BIOGRAPHICAL DICTIONARY

Ecclesiastical History of the Fifteenth and Sixteenth Centuries

24 BRIEF AND INCLUSIVE 78

15 A 10 A 20 a, 20 POINT GOTHIC CONDENSED No. 6. \$3.80

PHILOSOPHICAL POLITICIANS

The Constitutional History of England and Ireland

49 THIRTEEN VOLUMES 75

15 A 20 a, 24 POINT GOTHIC CONDENSED No. 6. \$4.80

56 ARTISTIC SELECTION 32

Collections of the Latest Operatic Music

10 A 12 a, 36 POINT GOTHIC CONDENSED No. 6. \$5.60

COAST 45 SURVEY

United States Internal Revenue

GOTHIC CONDENSED No. 6.

10 A 12 a.

40 POINT GOTHIC CONDENSED No. 6.

\$6.75

**Artistic Combination Borders
23 FLOURISHES 34**

6 A 10 a.

48 POINT GOTHIC CONDENSED No. 6.

\$7.75

**The Modern Sciences
PRINTING 18**

5 A 6 a.

60 POINT GOTHIC CONDENSED No. 6.

\$8.45

Roman BAR Storks

5 A 6 a.

72 POINT GOTHIC CONDENSED No. 6.

\$11.85

Graduations 35

GOthic CONDENSED No. 7.

CAST FROM SOLID COPPER MATRICES.—ORIGINAL.

25 A 20 A 40 a,

10 POINT GOTHIC CONDENSED No. 7.

\$3.10

INTERESTING ROCKY MOUNTAIN SPORTING ADVENTURES
Exciting Narratives of American Travels, Explorations and Discoveries
18 ANTELOPE OR BUFFALO HUNTERS 27

20 A 12 A 30 a,

12 POINT GOTHIC CONDENSED No. 7.

\$3.25

GREAT CLOSING CUT FURNITURE SALE.
Proceedings of the International Typographical Unions
15 RELIABLE COUNTRY PRINTERS 38

15 A 10 A 25 a,

18 POINT GOTHIC CONDENSED No. 7.

\$4.20

PHYSICIANS' MEDICAL LITERATURE
Hand-book of Practical Recipes and Formulas
13 STRICT STUDY 45

12 A 8 A 20 a,

22 POINT GOTHIC CONDENSED No. 7.

\$5.35

STATE COURT OF APPEALS
Constitutional SUPREME Jurisprudence

10 A 15 a,

28 POINT GOTHIC CONDENSED No. 7.

\$5.35

SPECIMEN JOB FACES
Five Mechanical Engineers 2

8 A 12 a,

36 POINT CONDENSED GOTHIC No. 7.

\$6.45

BOLDFACE GOTHICS
Heavy Condensed Runics

GOTHIC CONDENSED No. 7.

6 A 10 a.

40 POINT GOTHIC CONDENSED No. 7.

\$7.00

French Operatic Gems
2 ORIGINALS 3

6 A 10 a.

48 POINT GOTHIC CONDENSED No. 7.

\$9.75

Jereme 8 Avenue
RACE SING

5 A 6 a.

60 POINT GOTHIC CONDENSED No. 7.

\$10.80

Dime Shees 2

4 A 6 a.

72 POINT GOTHIC CONDENSED No. 7.

\$14.15

Fine Orators

ARCHED GOTHIC.

PATENT APPLIED FOR.

6 POINT ARCHED GOTHIC.
25A 20A 50a, \$2.60

Midnight Bathroom Reminiscences
Remarkable Adventures of an Over-crowded
LEAVE-TAKING OF SLUMBER
BOARDINGHOUSE SLAPJACKS

8 POINT ARCHED GOTHIC.
25A 20A 50a, \$3.15

Nineteen Hundred and Nine
Misunderstandings Never Corrected
GRINNING 54 GOSSIPS
MISCHIEF-MAKING MEN

20 A 20 A 40 a,

10 POINT ARCHED GOTHIC.

\$3.40

12 TRIUMPHS OF SIMEON GALL, ESQ 41

Indescribable Boastive Blandishments Greatly Overestimated
BRASS MOUNTED BOOK AGENT

15 A 15 A 30 a,

12 POINT ARCHED GOTHIC.

\$3.70

38 UNCONGENIAL RHEUMATISM 56

Comfortless Mustard Poultices For Lame Backs
DOMESTIC MEDICINES

10 A 10 A 20 a,

18 POINT ARCHED GOTHIC.

\$4.35

26 IMMELODIOUS ROOSTERS 35

The Terror-stricken Sunset Cackler
DOOMED GOBBLER

6 A 6 A 15 a,

24 POINT ARCHED GOTHIC.

\$5.05

26 CHILDHOOD 35

Currantbush Committees
SCRATCHES

✻ ARCHED * GOTHIC * CONDENSED ✻

CAST FROM SOLID COPPER MATRICES.

20 A 20 a.

12 POINT ARCHED GOTHIC CONDENSED.

\$1.95

CALIFORNIAN * TERRITORIAL * COLONIZATION * AND * EMIGRATION * COMMITTEE

Farmers' and Mechanics' Insurance Company. * Manufacturers' and Traders' Stock Exchange

23 ✻ Fidelity * National * Security * Association. ✻ 46

10 A 20 a.

18 POINT ARCHED GOTHIC CONDENSED.

\$2.35

ARGENTINE CONFEDERATION INDUSTRIAL EXPOSITION

Manufacturing Resources of Enterprising Republics of South America

✻ Exploring * Expedition * Falkland * Island ✻

10 A 15 a.

24 POINT ARCHED GOTHIC CONDENSED.

\$3.00

✻ AMERICAN * NATIONAL * BANKS ✻

Western Railroad Magnates Financial Operations

*** 75 Commercial Travelers 46 ***

6 A 10 a.

36 POINT ARCHED GOTHIC CONDENSED.

\$6.30

EDUCATIONAL * INSTITUTIONS

Musical, Literary and Theatrical Academie

North Cambridge University

COSMOPOLITAN.

PATENTED.

20 A 75 a,

8 POINT COSMOPOLITAN.

\$3.15

Under a Spreading Chestnut Tree the Village Smithy Stands;
The smith, a mighty man is he, with large and sinewy hands; and the
muscles of his brawny arms, are

THE OLD VILLAGE BLACKSMITH OF NEW ENGLAND.

Strong as iron bands.

15 A 50 a,

10 POINT COSMOPOLITAN.

\$3.10

Week in, and out, from Morn till Night, You can hear
His Bellows blow; you can hear him swing his heavy sledge
Like ringing the village bell,

12345 67890

15 A 40 a,

12 POINT COSMOPOLITAN.

\$3.15

Very Entertaining Concert Programmes
Seventh Annual Wednesday Evening Twilight Coterie
ASSEMBLAGE OF VETERANS

10 A 25 a,

18 POINT COSMOPOLITAN.

\$4.10

Cruise of the Yacht Atalanta
National Rowing Club Associations.

27 MONTAUK 41

8 A 15 a,

24 POINT COSMOPOLITAN.

\$4.40

Great Steeple Chase
Fleetwood Park Horse Race
JOCKEY CLUBS

— ❖ P E M B R O K E ❖ —



10 A 20 a.

18 POINT PEMBROKE.

\$2.45

Designed by Foundry Flinsch, of Germany.

The Word Ornaments and Logotypes of this Series are Original.

≡ H A R D + M E T A L + T Y P E ≡

6 A 15 a.

24 POINT PEMBROKE.

\$2.50

Bewitching Fairies, Basking in the Sunlight
Evening Dance of the Sirens in the Glen of Landroof

≡ B I L L + O F + F A R E ≡

5 A 15 a.

30 POINT PEMBROKE.

\$3.50

Abridged Specimens of Printing Types
Printing Materials, Brass Rule and Electrotypes

≡ C Y L I N D E R + P R E S S E ≡

5 A 10 a.

36 POINT PEMBROKE.

\$3.90

Ninth + Annual + Reception
Puritanical + Mardi + Gras + Carnival

≡ M O U N T A I N S E ≡

LIGHT MEDIAEVAL

CAST FROM SOLID COPPER MATRICES.

10 A 20 a.

12 POINT LIGHT MEDIAEVAL.

\$3.65

Third Grand Full Dress Reception
SIX SINGULARLY SOCIABLE SOLDIERS
Young Folks' Concert Music

10 A 20 a.

18 POINT LIGHT MEDIAEVAL.

\$5.50

Sierra Nevada Mountains
Western RHEINOLD Company
Mineral 47 Springs

8 A 12 a.

24 POINT LIGHT MEDIAEVAL.

\$6.05

Adventurous Prospectors
Interesting FARM Literature
Bountiful Vineyards

—♦— PURITAN —♦—

15 A 15 a.

18 POINT PURITAN.

\$4.25

YE ANCIENT YANKEE SINGIN' CLASS
HONORABLE NORTH AMERICAN PURITANS
KNIGHTS OF THE STIQUE

10 A 10 a.

24 POINT PURITAN.

\$5.40

OAKLAND MILITARY DISPLAY
BANQUET TO HIGH LOW JINKS
SOLEMN SORDID SOLDIERS

LATIN ORNATE AND SHADED

ORIGINAL.

15 A.

12 POINT LATIN ORNATE.

\$3.15

INTERESTING HISTORY
AMERICAN NAVAL COMMANDERS
3 UNITED STATES 2

8 A.

24 POINT LATIN ORNATE.

\$4.30

ESSAYS, DEBATES
LITERATURE

8 A.

24 POINT LATIN SHADED.

\$3.70

SCIENTIFIC COLLEGES
\$24 DIPLOMAS £83

26C EACH.

48 POINT LATIN ORNATE INITIALS.

ALPHABET, \$2.25.

A G K O S T

MARGUERITE

PORT OF INITIALS INCLUDE END SCROLLS. BRASS RULE TO LINE WITH SAME EIGHT CENTS PER FOOT.

GROTESQUE GOTHIC AND BELGRAVE.

— PATENTED —

20 A 20 A 30 a.

10 POINT GROTESQUE GOTHIC.

\$2.35

The American Printers' Society for Typographic Advancement
The Ambitious Workman Should Invariably be Encouraged to Merit Promotion
32 JAMESTOWN EVENING BULLET 45

20 A 20 A 30 a.

12 POINT GROTESQUE GOTHIC.

\$3.65

North American Army and Naval Review
Military Forces of the European Monarchical Governments
VETERAN GERMAN SOLDIERS

15 A 15 A 25 a.

18 POINT GROTESQUE GOTHIC.

\$4.05

BESTER WALLACK & COMPANY, ACTORS
Dramas, Pantomimes, Comedies, Tragedies, Farces,
39 + STAGE + STRUCK + 85

15 A 25 a.

18 POINT BELGRAVE.

\$2.90

George Washington Theological and Scientific Institution
12345 STANDARD AUTHORITY 67890

10 A 15 a.

24 POINT BELGRAVE.

\$3.25

Mercantile Safe Deposit and Insurance Co.
47 MARINE ARTIST 38

8 A 12 a.

36 POINT BELGRAVE.

\$4.45

Saratoga Mineral Water Springs
7 OLD PORT WINE 3

GROTESQUE ORNAMENTED

10 A 15 s.

24 POINT GROTESQUE ORNAMENTED.

\$4.95

Twenty-Fifth Wedding Anniversary
ANTEDILUVIAN : PROGNOSTICATIONS
Ocean Observatory Park

6 A 10 s.

40 POINT GROTESQUE ORNAMENTED.

\$5.45

United States Coast Survey
TOPOGRAPHICAL DELINEATOR
Civil Engineering News

—+—+ LINEAR : SHADED. +—+—

PATENTED.

8 A.

18 POINT LINEAR SHADED.

\$3.00

MENLO MUSICAL MARKS
37 : CONCERT : 54

6 A.

24 POINT LINEAR SHADED.

\$4.00

SPRING 4 ROBINS
AUTUMN

5 A.

36 POINT LINEAR SHADED.

\$6.00

3 BINDERS 6

EGYPTIAN SHADED.

PATENTED.

20 A 25 a, 10 POINT EGYPTIAN SHADED. \$4.50
Keyle's Practical Scenery and Antiquities of Ireland
12 ANTIQUARIANISM ON DRAUGHT 41

15 A 20 a, 12 POINT EGYPTIAN SHADED. \$5.00
Store of The Construction and Navigation
12 DEPARTMENT 39

10 A 15 a, 18 POINT EGYPTIAN SHADED. \$6.00
Deciphering Comic Inscriptions
15 BOSTON COMMON 6

6 A 10 a, 22 POINT EGYPTIAN SHADED. \$5.40
Studies of Famous Men
12 HERMIT 13

5 A 8 a, 28 POINT EGYPTIAN SHADED. \$6.70
American Sketch 8
NURSERIES

3 A 6 a, 36 POINT EGYPTIAN SHADED. \$6.55
Cheap Printers
2 MORAL 3

3 A 4 a, 40 POINT EGYPTIAN SHADED. \$8.40
River Stores

OBLIQUE AND INVERTED SHADE.

CAST FROM SOLID COPPER MATRICES.

PATENTED.

8 A 10 A, 18 POINT OBLIQUE SHADED. \$5.45
AFRICA STATE UNITED
48 CONSTITUTION 57

8 A, 24 POINT OBLIQUE SHADED. \$4.95
GRAND SPANISH
3 HISTORY 5

4 A, 36 POINT OBLIQUE SHADED. \$5.75
TRADITIONS

10 A, 12 POINT INVERTED SHADE. \$4.65
GRAMMATICAL
3 MUSIC 4

8 A, 18 POINT INVERTED SHADE. \$6.10
GUARDING
CLING

5 A, 24 POINT INVERTED SHADE. \$6.10
MORTAL

3 A, 30 POINT INVERTED SHADE. \$8.60
MOAN

NEW SHADED FACES.

CAST FROM SOLID COPPER MATRICES.

6 A 12 A, 18 POINT MONASTIC SHADED. \$2.50
HENRIQUES FRENCH PASTELS FOR CRAYON DRAWING
78 AUERBACH'S NEW VILLAGE STORIES 13

5 A 10 A, 24 POINT MONASTIC SHADED. \$1.50
NEW ENGLAND BERKSHIRE PAPER MILLS
30 BOSTON TRADES JOURNAL 15

3 A 6 A, 36 POINT MONASTIC SHADED. \$1.90
THE AMERICAN BOOK EXCHANGE
EDITORIAL CONVENTION

3 A 6 A, 40 POINT MONASTIC SHADED. \$4.00
CHARMING SERIAL STORIES

10 A 15 A, 18 POINT CURVED GOTHIC SHADED. \$3.50
Before the Period of the Renaissance A. D. 1848
UNIQUE MASQUERADE COSTUMES

8 A 12 A, 24 POINT CURVED GOTHIC SHADED. \$4.75
Heliotypes of Photo-Zinc Engraving
12 COOPER ART UNION 35

6 A 10 A, 36 POINT CURVED GOTHIC SHADED. \$6.25
Popular 2 STATE 8 History

ORNAMENTAL SPECIMENS.

PATENTED

10 A 15 a

18 POINT ORNAMENTED No. 37

\$5.25

Ohio Coal Mining Company
Second Monthly Finance Dividend
34 COMMERCIAL 35

6 A 10 a

24 POINT ORNAMENTED No. 41

\$5.85

Roanoke Market Reports
42 NORMAN 53

4 A 6 a

36 POINT ORNAMENTED No. 36.

\$7.00

Athenia 4 Hamblin

6 A 10 a

28 POINT ORNAMENTED No. 42

\$5.20

Irish Domestic Productions
Mercantile Insurance Corporations
5 MOUNTAIN 7

5 A

40 POINT ORNAMENTED No. 18

\$5.85

OREGONIANS 2

OLD STYLE EGYPTIAN.

PATENTED.

25 A 40 a,

8 POINT OLD STYLE EGYPTIAN.

\$2.90

Shall This Bill Pass the House to be Enacted?

CIBARIOUS LACTESCENT COMPOUNDS FROM KINE & CO.

76 Expert Milk-Maidens. 25

Vegetable Life as Seen Through a Microscope

20 A 15 A 20 a,

10 POINT OLD STYLE EGYPTIAN.

\$3.00

Garments Guaranteed to be Artistic

PERFECTION IN FOREIGN CUT CLOTHES

18 TAILOR-MADE GOODS 73

15 A 10 A 20 a,

12 POINT OLD STYLE EGYPTIAN.

\$4.05

Elaborate Gastronomic Feat

BILL OF FARE COLLABORATOR.

42 FRIED BIVALVES! 63

10 A 10 A 15 a,

18 POINT OLD STYLE EGYPTIAN.

4.80

British Frontier War

AUSTRIAN JUNGLE LIFE

89 BOOMERANG 67

8 A 6 A 12 a,

24 POINT OLD STYLE EGYPTIAN.

\$6.05

Modern Designers

SCENIC PAINTINGS

BRUSH WORKER

AMALGAMATED AND NOVELTY SCRIPTS.

CAST FROM SOLID COPPER MATRICES.

PATENTED.

10 A 25 a.

12 POINT AMALGAMATED SCRIPT.

\$3.00

*The books of Baskerville are valuable to the
Modern Printer only as Marking the Transition from the
Old Style to the New
456 Symmetry of Line and Curve 123*

8 A 20 a.

18 POINT AMALGAMATED SCRIPT.

\$4.50

*Magazine of Useful Information
According to Varro, Paper was invented by
234 Alexander the Great 567*

8 A 15 a.

22 POINT AMALGAMATED SCRIPT.

\$5.50

*James Conner's Sons
Adapted for Mercantile Printing.
3 Amalgamated Script 8*

10 A 30 a.

18 POINT NOVELTY SCRIPT.

\$6.00

*The Book Compositor.
There is no Class of Men connected with
the Printing Business whose interests are
so often overlooked by their Fellow-
Craftsmen as the Book Comps.
Bought of 1234567890 Altoona, Pa.*

Large Face Scripts.

COPYRIGHTED.

1

12 A 120 a.

12 POINT SCRIPT No. 2.

\$11.60

Shipped, in good order, and condition by Jas. Conner's Sons on board the Steamship George Washington, whereof A. Gager is Master for this voyage, now lying in the Port of New York, and bound for New Orleans, La., To say: Eight Boxes Merchandize being marked and numbered as in the margin, and are to be delivered in like order and condition, at the Port of New Orleans, the dangers of the seas only excepted, unto George H. Vinten, or to his assigns, he or they paying freight and charges in United States Currency, as entered in the margin hereof, with primage and average accustomed. In witness whereof the Master or Purser of the said vessel hath affirmed to four Bills of Lading, all of this tenor and date; one of which being accomplished, the others to stand void.

Dated in New York, the Eleventh day of August, 1866.

12 A 80 a.

18 POINT SCRIPT No. 4.

\$13.00

The very large Face of the Script shown in this Specimen compared to its Body—Great Primer—renders it well adapted to printing Certificates, Deeds, Leases, Bonds, and other Blanks; also to work in which a limited Space prevents the use of Scripts with larger bodies. It is equally useful for Circulars, Receipts, Orders, and many other kinds of Work.

James Conner's Sons.

Venetian, and Law Italic.

CAST FROM SOLID COPPER MATRICES.

20 A 60 s. 10 POINT VENETIAN. \$4.90

*The Science of Mathematical Demonstration, both in
Law and in other Departments of Inquiry where we do with mere
Probabilities, is long in being brought to Perfection.*

75 THE SCIENCE OF EVIDENCE. 18

20 A 50 s. 12 POINT VENETIAN. \$4.20

*Philosophers of this sort Picture to the Imagination
Virtue as being the most Valuable and Lovely of all Objects*

71 MORAL PHILOSOPHY. 85

10 A 30 s. 18 POINT VENETIAN. \$6.15

Life is the First Study of all Polite Nations

57 GREEK LANGUAGE. 81

25 A 75 s. 8 POINT LAW ITALIC. \$4.05

*This is to Certify, that I have hired and taken of
GEORGE JAMES, of the City of Brooklyn, in the County of Kings,
State of New York, the House and Lot known
UNITED STATES SUPREME COURT*

15 A 40 s. 10 POINT LAW ITALIC. \$2.80

*This Indenture, made the first day of May,
One Thousand Eight Hundred and Seventy-four, between*

5 COMMISSIONER OF DEEDS. 7

15 A 40 s. 12 POINT LAW ITALIC. \$3.50

*Know all Men, that I, WILLIAM LOT,
of the State, City and County of York, for the sum*

17 ONE THOUSAND DOLLARS 58

Herriet Scripts.

CAST FROM ORIGINAL MATRICES.

12 POINT HERRIET SCRIPT.

CARD FONT, 4A, 15a \$3.00
JOB FONT, 8A, 20a 6.00
CIRCULAR FONT, 12A, 50a 9.00

*Special Attention is Called to this Series of Script,
It Possesses Many New and Valuable
Improvements of Our Own Invention, Covered by Patents
1234 No more script prices for leads. 5678
Can be set Solid as well as Leaded.*

18 POINT HERRIET SCRIPT.

CARD FONT, 4A, 10a \$3.10
JOB FONT, 8A, 20a 6.20
CIRCULAR FONT, 12A, 50a 12.00

*Third Grand Knickerbocker Reception.
Dainty Favors for the Ladies.
Messrs. Taylor & Cutter, Artistic Habilitments
234 Academy of Music. 567*

24 POINT HERRIET SCRIPT.

CARD FONT, 4A, 10a \$4.50
JOB FONT, 8A, 20a 9.00
CIRCULAR FONT, 12A, 50a 17.10

*Type, Presses, Cabinets, Cases
Conner's Type Foundry
Centre, Beade and Duane Streets,
23 Printing Materials. 45*

Gotham Scripts.

CAST FROM ORIGINAL MATRICES

12 POINT GOTHAM SCRIPT.

CARD FONT, 4A 15a, \$3.00
JOB FONT, 8A 30a, 6.00
CIRCULAR FONT, 12A 50a, 9.00

*Triennial Masonic and Military Conclave
The Flanders White Brigade
Drop Letters of this Series Cast with Patent Support
12 Grand Army of the Republic. 34
Island National Guard.*

18 POINT GOTHAM SCRIPT.

CARD FONT, 4A 10a, \$3.25
JOB FONT, 8A 20a, 6.50
CIRCULAR FONT, 12A 50a, 12.75

*Your Presence Requested at the
Banquet Tendered to Mayor O'Sullivan
Our Juvenile Map Meetings.
1234 Delmonico's Beanery 5678*

24 POINT GOTHAM SCRIPT.

CARD FONT, 4A 10a, \$4.95
JOB FONT, 8A 20a, 9.90
CIRCULAR FONT, 12A 50a, 19.35

*Vendome Theologic School.
Wilmington Advertiser
A National Flirtation Society.
Jno M. Dunbar & Co*

Stylographic Text. Q.

PATENTED

25 A 40 a,

10 POINT STYLOGRAPHIC TEXT.

\$4.15

It Takes High Rank among the Latest Elegant

All Lovers of Fine "Art Printing" will Welcome this Superb Series.

12345 Productions of this Foundry. 67890

15 A 30 a,

12 POINT STYLOGRAPHIC TEXT.

\$4.20

A more Popular, more Appropriate, or

Elegant Selection than this Series could not be Made

45 by the most Fastidious. Q 68

8 A 25 a,

18 POINT STYLOGRAPHIC TEXT.

\$4.80

*James Tonner's Sons New Specimen
Book is the Result of Years of Diligent and
67 Careful Study and Labor. 89*

10 A 15 a,

18 POINT CURVED EGYPTIAN.

\$4.25

*National Rowing Associations
Grand Annual Regatta of the Valeencias
SUMMER RESORTS
Boston Summer Dakota Winter
84 Blue Fishing Club 70*

NUBIAN CONDENSED.

PATENT PENDING.

15 A 25 s.

18 POINT NUBIAN CONDENSED.

\$5.00

Our Renowned African Lake Explorers.
Exerciating Agonies of American Wedded Existence.

75 HAPPY BRIDES 43

Southern Maidens of Mahogany Complexion.

10 A 20 s.

24 POINT NUBIAN CONDENSED.

\$5.40

Busky Pugilistic Nubian Warriors.
Garmented Heathens Striking for Short Clothes!

74 BRAGGARAN 39

Uncompromising Cannibals Painted Black.

9 A 15 s.

36 POINT NUBIAN CONDENSED.

\$6.70

Panorama of Revolutionary War.
Vivid Pictures of That Great Struggle.

35 LAFAYETTE 27

OCTAGON SHADED.

PATENTED.

15 A.

12 POINT OCTAGON SHADED.

\$1.80

**WILLIAM CAXTON OF KENT
HIGH-MINDED AND OPEN-HEARTED
11 BORN IN WEALD 14**

12 A.

18 POINT OCTAGON SHADED.

\$2.50

**WYNKYN DE WORDE
EXCELLENT COMPOSITION
\$1284587890**

10 A.

24 POINT OCTAGON SHADED.

\$3.65

**BOOKBINDERS
FREDERICKSBURG!
15 THIRD 20**

6 A.

36 POINT OCTAGON SHADED.

\$4.40

**BRADFORD
BOOK 93 TYPE**

SIRIUS SERIES

8 A 15 a.

12 POINT SIRIUS.

\$3.35

**Ancient Order of United Americans
Direct for Sandwich Islands and Australia
DUPLIX TICKET CONCERN**

5 A 8 a.

18 POINT SIRIUS.

\$3.75

**Soap-Manufacturers' Hop
Tuesday Evening, October 14th,
ISLAND JOURNAL**

5 A 8 a.

24 POINT SIRIUS.

\$5.00

**Presidential Returns
Correct Daily Telegrams
REPORTORIAL**

4 A 6 a.

36 POINT SIRIUS.

\$7.30

**National Bank
Protestant Church
UNIVERSE**

MODERN BLACKS.

CAST FROM ORIGINAL MATRICES.

- 20 A 50 a, 6 POINT MODERN BLACK. \$2.00
Scenes of Wonder and Curiosity in California and the Sierra Nevada
Nevada and California Practical Processes of Gold and Silver Extraction Courlet's Guide to the Yosemite
12 *Hausberg München* 34
- 20 A 50 a, 8 POINT MODERN BLACK. \$2.55
The Illustrated Quarterly Educational Magazine
Literature of Europe In the Fifteenth, Sixteenth and Seventeenth Centuries, with
12 Portraits and Introduction Biography 34
- 15 A 40 a, 10 POINT MODERN BLACK. \$2.45
Parallel Extracts, Arranged for Translation into English and Latin
Ellis' Practical Hints on the Quantative Pronunciation
Latin, for the Use of Teachers and Linguists
12 Fragments of Early Latin 34
- 12 A 30 a, 12 POINT MODERN BLACK. \$2.40
Chapters on the History and Development of Languages
12 *Beitschrift für Praktische Baukunst* 34
Charters and Documents Illustrative of the Constitutional
History of the English Nation
-
- 15 A 40 a, 8 POINT BLACK NO. 3. \$1.75
'T is the Middle Watch of a Summer's Night, the
Earth is Dark but the Heavens are Bright; Naught is Seen in the Vault on High but
the Moon, the Stars, the Cloudless Sky, and the Ruler of Night
on the Welkin Blue Sunday School Scholars.
-

Modern Black No. 2.

CAST FROM SOLID COPPER MATRICES.

- | | | |
|---|------------------------------|--------|
| 30 A 50 a, | 6 POINT MODERN BLACK, No. 2 | \$4.50 |
| Suppose there was in the White House a President
Shrewd enough to Know When and How to do Right, What Then?
Government for the People and by the People. | | |
| 25 A 40 a, | 8 POINT MODERN BLACK, No. 2 | \$2.65 |
| Fair Competition is Healthy; it Breaks up
Monopoly and Places a Reasonable Value on Commodities
Which could not be Accomplished Otherwise | | |
| 25 A 10 a, | 10 POINT MODERN BLACK, No. 2 | \$2.50 |
| Observation and Practical Experience
Respecting the Things Worth Knowing in Life
Art of Giving Well and Cheaply | | |
| 8 A 20 a, | 12 POINT MODERN BLACK, No. 2 | \$2.45 |
| Stereotyping and Electrotyping:
Instruction for Depositing Copper Plates
Production of Papier-maché | | |
| 12 A 20 a, | 14 POINT MODERN BLACK, No. 2 | \$3.20 |
| Collection of Articles in Prose,
Covering every Phase of Married Life
Humorous and Versatile | | |
| 6 A 15 a, | 18 POINT MODERN BLACK, No. 2 | \$2.95 |
| A General Text-Book for
Those Knowing the Origin of Man | | |

Text and Text Italic.

6A 10A. 18 POINT TYPE. 64 MI.
First United States National Bank of Jefferson
1284 Bonds and Mortgages. 6789

7A 10A. 18 POINT TYPE. 64 MI.
Fourteenth Senatorial State District

8A 10A. 18 POINT TYPE. 64 MI.
North Zambesi Expedition

9A 10A. 18 POINT TYPE. 64 MI.
Scientific & Colleges

10A 10A. 18 POINT TYPE ITALIC. 64 MI.
Disastrous Consequences of the Greely Expedition
42 History of the Arctic Region 17

11A 10A. 18 POINT TYPE ITALIC. 64 MI.
Mutual Protection for Antique Monuments

12A 10A. 18 POINT TYPE ITALIC. 64 MI.
Seventeenth Century Literature

13A 10A. 18 POINT TYPE ITALIC. 64 MI.
Historical American

Hamburg Text.

CAST FROM SOLID COPPER MATRICES.

30 A 50 s. 6 POINT HAMBURG. \$2.35

January, which is now the first Month of the Year, did not always occupy this Honorable Position among The English Speaking People. In the British Islands the Year began 347 On the 25th of March until 1752, when it was altered. 289

20 A 40 s. 8 POINT HAMBURG. \$2.45

The Romans Called it "Martius," in honor of the God Mars. March is the Third Month in our Modern Year, it Contains Thirty-one Days In Ancient Rome it was the First Month.

15 A 30 s. 10 POINT HAMBURG. \$2.50

Death Throes of Winter and Birth Pangs of Spring. He was their God of Thunder, and also the God of the Heavens. 36 Giving the Darkness and Sunshine. 73

15 A 30 s. 12 POINT HAMBURG. \$2.85

These Fonts are all Supplied with Spaces and Quads, for which no Charge is Made, thus enabling Printers, 2 to use them without additional expense. 6

15 A 25 s. 14 POINT HAMBURG. \$3.30

Exhaustive Mathematical Researches Has Proven our Fonts Superior to All Others 3 in their Relative Proportions 5

— Hamburg Text. —

CAST FROM SOLID COPPER MATRICES.

10 A 20 s.

18 POINT HAMBURG.

\$3.50

The Sage Brush Literary Union.
Women May Weep, Sages May Frown.
3 Angels of Grim Death. 5

6 A 20 s.

22 POINT HAMBURG.

\$3.75

The United States Convention
Peace on Earth, Good Will to Man
Methodist-Episcopal

5 A 20 s.

24 POINT HAMBURG.

\$4.35

Central Park Belvedere
Hotel de Doronuss Francais
Spanish Theatres

5 A 12 s.

28 POINT HAMBURG.

\$4.35

Hamburg Loan and Trust
\$6 Association \$8

**COMBINATION
GRECIAN BORDER, No. 133.**

PATENTED.

FIRST SECTION.

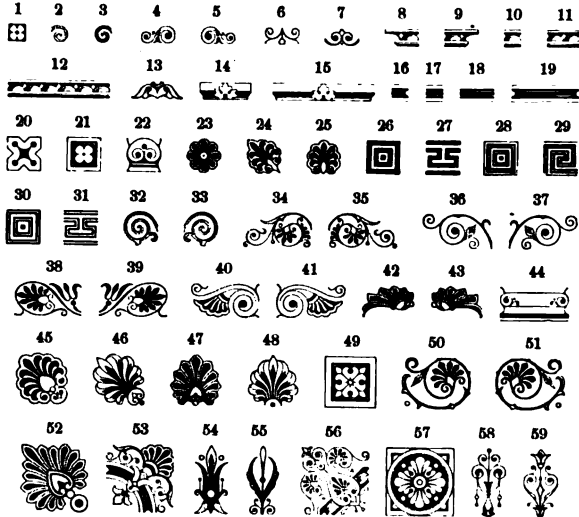

SECOND SECTION.

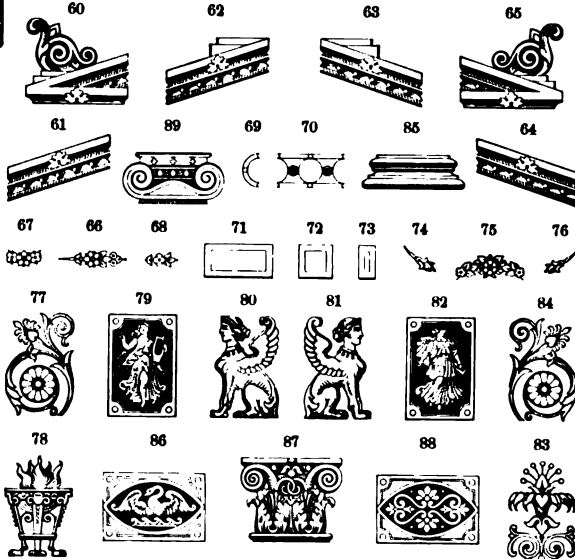

SECTION ONE, \$4.85.

SECTION TWO, \$4.15.

PER FONT, \$9.00.

N. C. HAWKS, SAN FRANCISCO.

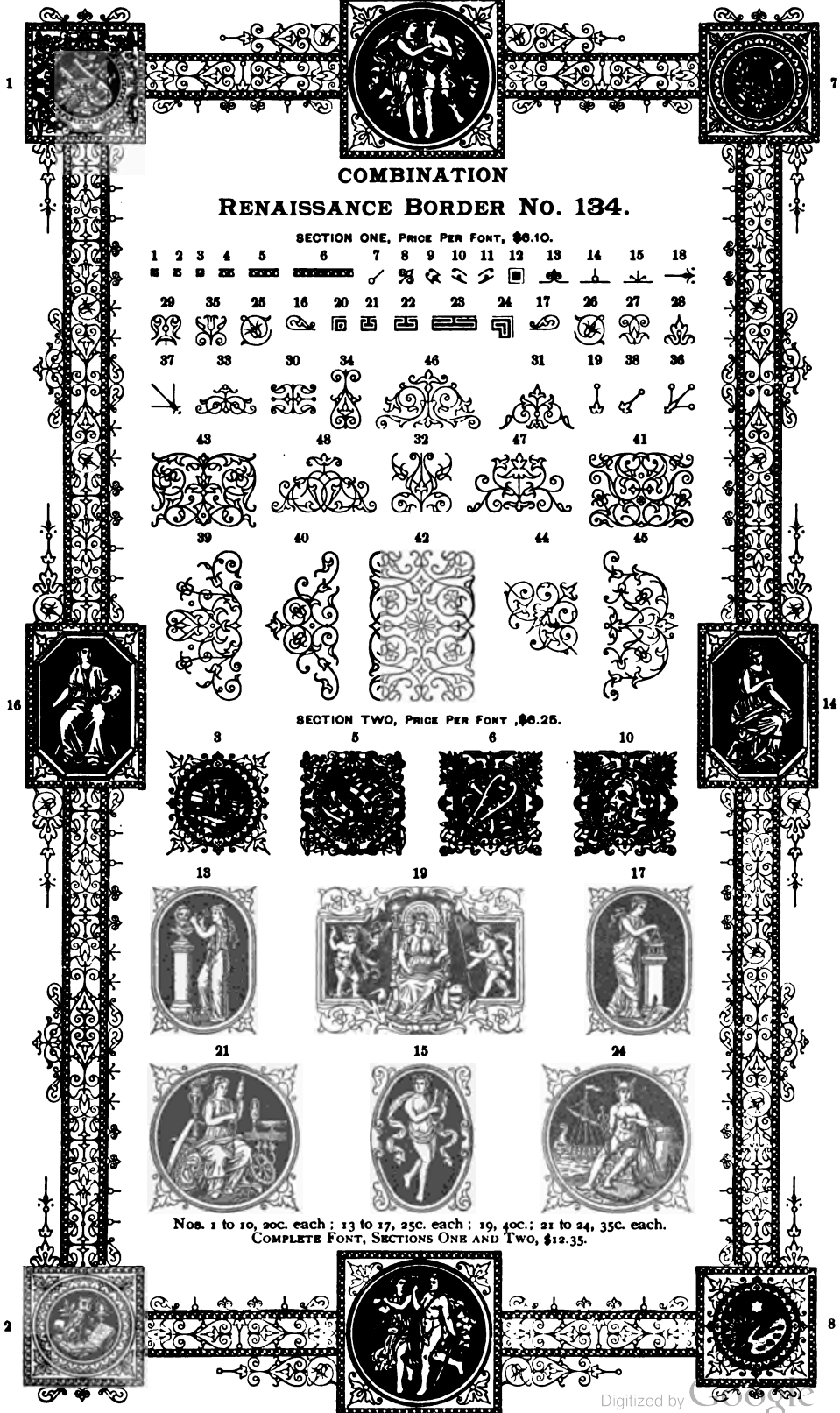

COMBINATION

RENAISSANCE BORDER NO. 134.

SECTION ONE, PRICE PER FONT, \$6.10.

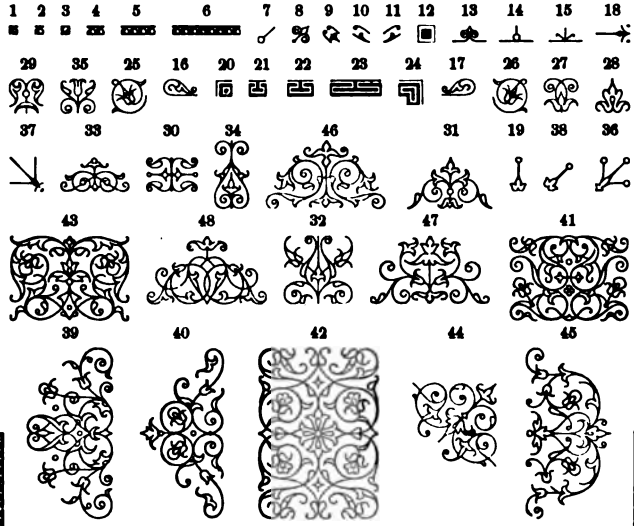

SECTION TWO, PRICE PER FONT, \$6.25.

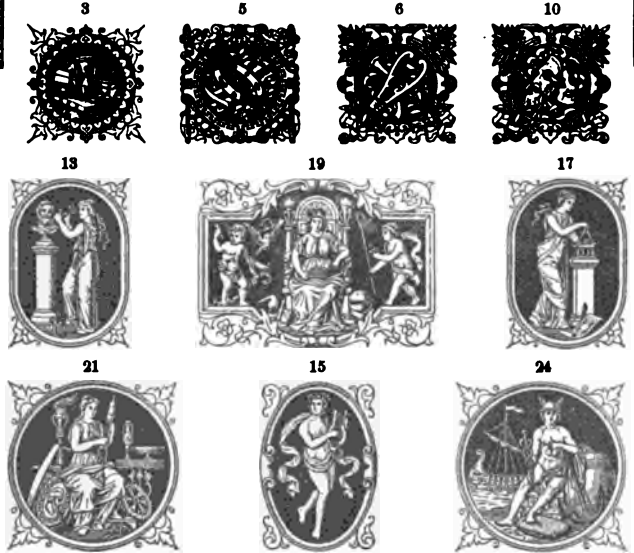

Nos. 1 to 10, 20c. each ; 13 to 17, 25c. each ; 19, 40c.; 21 to 24, 35c. each.
 COMPLETE FONT, SECTIONS ONE AND TWO, \$12.35.

ARCHITECTURAL ORNAMENTS.

Nos. 11, 12, 13, 18, 20, 23, 25 and 27, 5 cents each; Nos. 1, 2, 3, 4, 5, 6, 17, 19, 22, 24 and 26, 12 cents each; Nos. 9, 10, 14, 15, 16 and 21, 15 cents each; Nos. 7 and 8, 20 cents each.

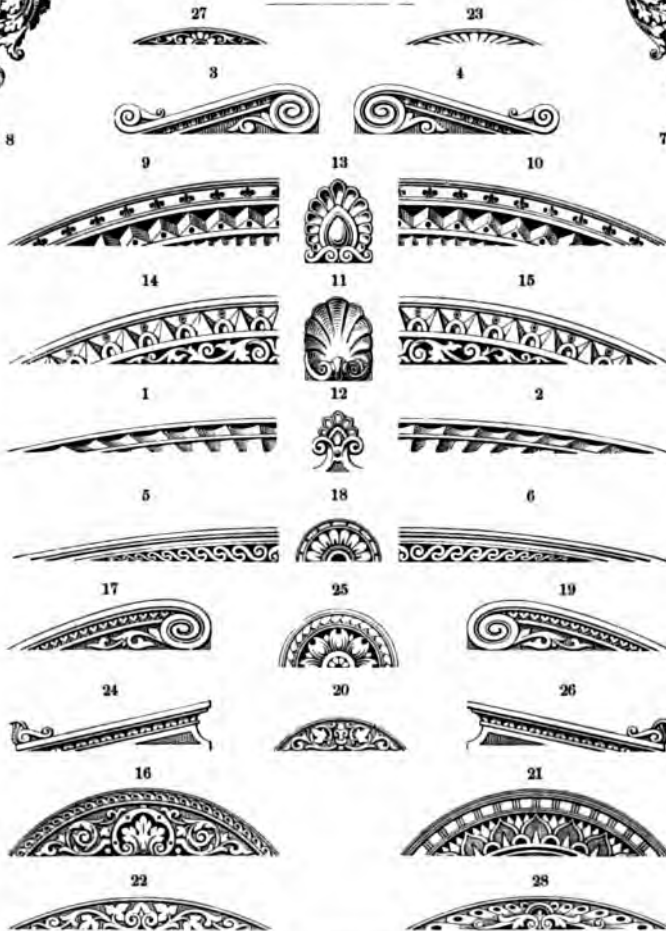

COMBINATION BORDER, NO. 141.



PER FONT, \$1.40

N. C. HAWKS, SAN FRANCISCO.

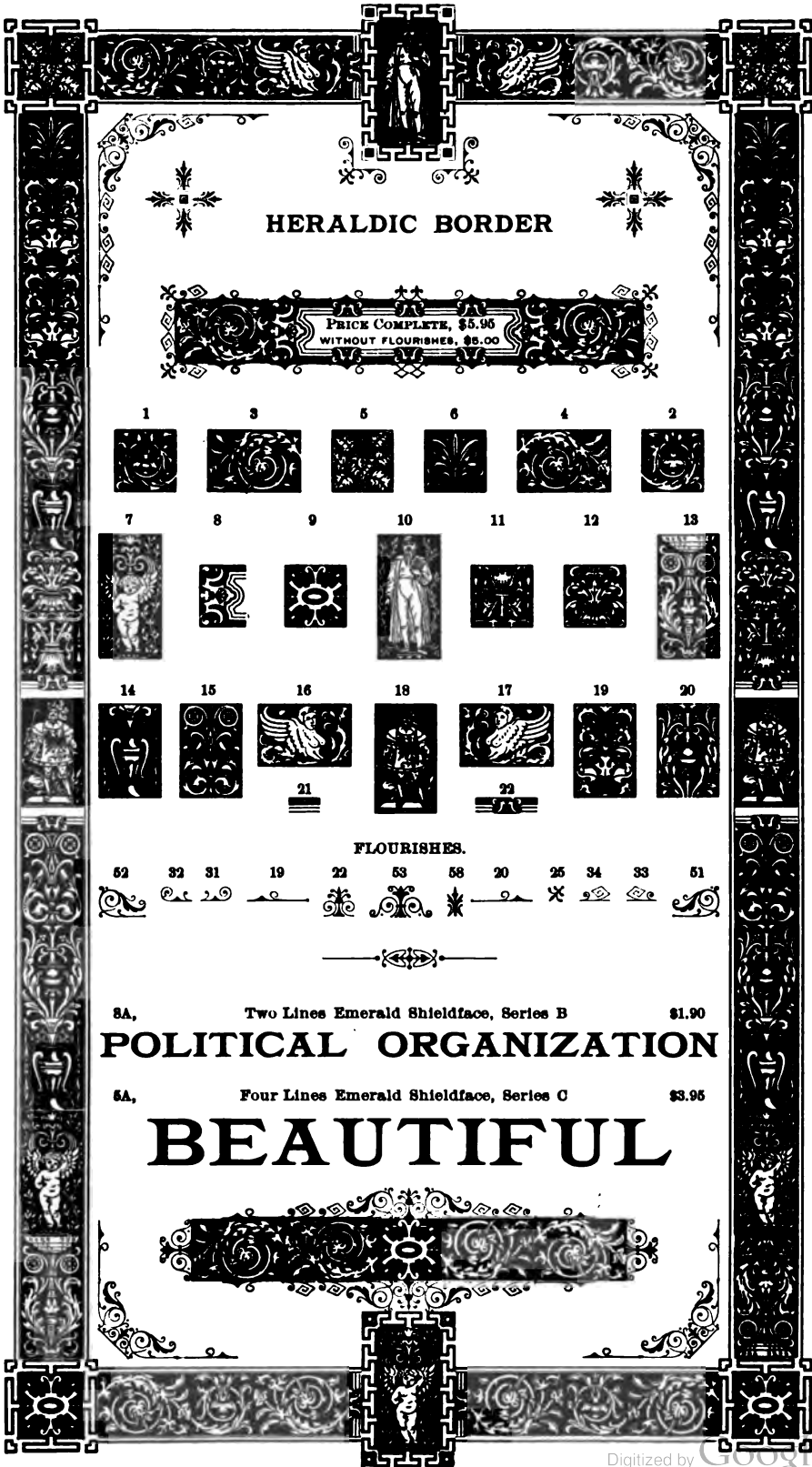

HERALDIC BORDER

PRICE COMPLETE, \$5.95
WITHOUT FLOURISHES, \$8.00

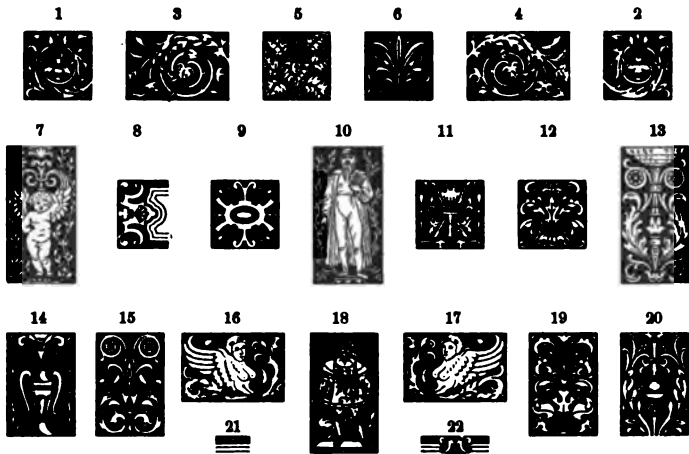

FLOURISHES.



8A, Two Lines Emerald Shieldface, Series B \$1.90
POLITICAL ORGANIZATION

6A, Four Lines Emerald Shieldface, Series C \$3.95

BEAUTIFUL



ILLUSTRATED CORNERS.

9 \$1.00



1 75c.



3 75c



7 75c



4 \$1.00



2 75c



6 \$1.00



5 75c



10 \$1.00



8 \$1.00



EXTRA CONDENSED No. 6.

30 A 60 a	8-POINT EXTRA CONDENSED No. 6	\$3.20
FORTY FUNNY FELLOWS ARE FOLLOWING THE SHADOWY Sunbeams and the Sweet Hopes We Have Cherished Are Low Lying 73256		
24 A 50 a	10-POINT EXTRA CONDENSED No. 6	\$3.00
Cormeilles Leads a Virtuous and Pious Life 1 2 3 4 5 6 7 8 9 0 DOUBLE BARRELLED ENGLISH SHOTGUNS		
18 A 36 a	12-POINT EXTRA CONDENSED No. 6	\$2.80
HUMDRUM EXISTENCE OF THE PLODDER WHOSE Innermost Soul is Not Above Pennies 3426		
12 A 25 a	16-POINT EXTRA CONDENSED No. 6	\$3.15
78432 BROOKLETS WILD BABBLING Down the Mountain Side Chirp and flutter		
10 A 20 a	20-POINT EXTRA CONDENSED No. 6	\$3.05
TIS SAID GRAND STREAMS FROM Brooklets to the Ocean Flow 87		
8 A 15 a	24-POINT EXTRA CONDENSED No. 6	\$3.15
HORRORS OF THE Fields of the Battle of Shiloh 751		
6 A 12 a	36-POINT EXTRA CONDENSED No. 6	\$5.15
MORE POWERFUL Than Bonaparte 215		
6 A 12 a	42-POINT EXTRA CONDENSED No. 6	\$6.25
BLACK GENTLEMEN in the Forest 43		
5 A 10 a	48-POINT EXTRA CONDENSED No. 6	\$6.45
MY SARAH Lies Dreaming 24		

BISQUE.

20 A	10-POINT BISQUE.	\$1.10
BABY ELEPHANTS AND CELEBRATED BLACKVILLE TWINS	3652	
15 A	12-POINT BISQUE.	\$1.10
LILY CLAYS ADAMLESS EDEN COMEDY TROUPE	435	
15 A	18-POINT BISQUE.	\$1.85
TAKE GREAT CARE OF THE PENNIES	453	
12 A	20-POINT BISQUE.	\$2.10
THE APPLE WOMANS CRIME	376	
10 A	24-POINT BISQUE.	\$2.25
DYNAMITE EXPLOSIONS	368	
8 A	36-POINT BISQUE.	\$3.65
OUR PRESIDENTS	56	
6 A	42-POINT BISQUE.	\$3.60
DREAD ANARCHY	1	
5 A	48-POINT BISQUE.	\$4.10
WARM RAINS	4	
5 A	60-POINT BISQUE.	\$6.05
GUM SHOP	5	
4 A	72-POINT BISQUE.	\$6.65
THE KIDS	3	

LIGHT MODERN.

10 A 15 a

24-POINT LIGHT MODERN

\$5.00

GENERAL AGENTS
Printers' Supply House 28

8 A 12 a

30-POINT LIGHT MODERN

\$5.00

ROCKY HOUSE
Printers' Supplies 54

6 A 10 a

36-POINT LIGHT MODERN

\$6.90

THOUSANDS
Ladies or Gents 2

5 A 8 a

48-POINT LIGHT MODERN

\$8.65

HUNDRED
Curley Heads 7

CIRCULAR GOTHIC.

6-POINT CIRCULAR GOTHIC

Caps, 30 A \$1.75

Lower Case, 75 a \$2.25

IMPORTERS AND WHOLESALE DEALERS IN ALL KINDS OF FOREIGN GOODS

The Electors shall Meet in their Respective States and shall vote by Ballot for President and Vice President

234 Magnificent and Fashionable Mahogany and Black Walnut Drawing Room Furniture 567

8-POINT CIRCULAR GOTHIC

Caps, 25 A \$1.60

Small Caps, 25 A \$1.30

Lower Case, 75 a \$3.00

LARGEST FURNITURE MANUFACTURER IN THE UNITED STATES

Most Magnificent and Fashionable Mahogany and Black Walnut Drawing Room Furniture

6235 HOTELS WERE CROWDED AT ALL THE EASTERN SUMMER RESORTS 3624

10-POINT CIRCULAR GOTHIC

Caps, 20 A \$1.50

Small Caps, 20 A \$1.15

Lower Case, 50 a \$1.90

WORCESTERS ENGLISH DICTIONARY WITH ENGRAVINGS

The Shakspeare Burns Byron and Longfellows Poems Nicely Bound in Cloth

8435 LARGEST PRINTING ESTABLISHMENTS IN THE UNITED STATES 5765

12-POINT CIRCULAR GOTHIC

Caps, 15 A \$1.60

Small Caps, 15 A \$1.20

Lower Case, 40 a \$2.05

THE NEW YORK AND PHILADELPHIA DEALERS

Largest Importations From the most Celebrated European Markets

43 LITHOGRAPHS AND PHOTOGRAPHS 53

16-POINT CIRCULAR GOTHIC

12 A 20 a \$4.35

12 A \$1.80

TWENTY SECOND OF FEBRUARY

The Fashionable Dress Makers Associations

234 THE CHICAGO DEALERS 457

24-POINT CIRCULAR GOTHIC

8 A 15 a \$4.20

8 A \$1.60

MONTHLY JOURNAL

Twelve to Seventy Copies Sold

42 MAGAZINES 34

Hawks & Shattuck, San Francisco.

Digitized by Google

GOTHIC No. 6.

24 A 50 a	6-POINT GOTHIC No. 6	\$1.60
8962354 HIEROGLYPHICS FROM THE EGYPTIAN PYRAMIDS Persian and Assyrian Uniforms Fresh Bright and New		
24 A 50 a	8-POINT GOTHIC No. 6	\$2.00
PRESERVED IN SCARLET LETTERS WRITTEN To The Italian Marble Fawn on Silverine 345678		
20 A 40 a	10-POINT GOTHIC No. 6	\$1.90
28 PRESERVED SCARLET LETTERS WRITTEN to the Italian Fawn on Bricks 68		
15 A 30 a	12-POINT GOTHIC No. 6	\$2.00
79 GRAPHIC CHARCOAL SKETCHES by Eminent Artists of Europe		
10 A 20 a	18-POINT GOTHIC No. 6	\$2.55
EVERY TOWN Knoweth Him More or Less 34		
8 A 15 a	24-POINT GOTHIC No. 6	\$3.70
68 BE ALLOWED To Choose		
6 A 10 a	30-POINT GOTHIC No. 6	\$5.15
Strange PEOPLE 5		
5 A 8 a	36-POINT GOTHIC No. 6	\$5.75
TYPE Foundry 23		
4 A 6 a	48-POINT GOTHIC No. 6	\$7.65
HER Parrot 8		

LINING GOTHIC

40 A 6-POINT LINING GOTHIC No. 19 \$1 05
THE ELECTORS SHALL MEET IN THEIR
RESPECTIVE STATES AND VOTE BY BALLOT FOR 234567

40 A 6-POINT LINING GOTHIC No. 16 \$1 75
THE EASTERN BRANCH
TWO MARBLE FRONT BUILDINGS 79

40 A 6-POINT LINING GOTHIC No. 18 \$1 30
MAGNIFICENT AND FASHIONABLE
BLACK WALNUT AND MAHOGANY FURNITURE 34

40 A 6-POINT LINING GOTHIC No. 15 \$1 85
HANDSOME NOVELTIES
THE PRINTERS' TYPE STANDS 23

40 A 6-POINT LINING GOTHIC No. 17 \$1 55
IMPORTER AND WHOLESALE
DEALER IN ENGLISH WOOLEN GOODS 56

30 A 8-POINT LINING GOTHIC \$1 80
EVENING PAPERS
THE FLORISTS' JOURNAL 3

20 A 10-POINT LINING GOTHIC \$1 65

FINE PRINTERS STATIONERS
AND BLANK BOOK MANUFACTURERS 574

20 A 12-POINT LINING GOTHIC \$2 10

THE PATENT DUPLEX
POCKETS NEVER TO RIP OR TEAR 5

12 A 18-POINT LINING GOTHIC \$2 70

38 MONEY AND STOCK

8 A 24-POINT LINING GOTHIC \$3 10

SOUND TEAMS 8

6 A 30-POINT LINING GOTHIC \$3 50

7 AMERICANS

4 A 36-POINT LINING GOTHIC \$3 35

PRINTERS 3

The six largest sizes line at both top and bottom.

Hawks & Shattuck, San Francisco.

GOTHIC EXTRA CONDENSED.

20 A 40 a 12-POINT GOTHIC EXTRA CONDENSED \$2.60
MALEDICTIONS DISTRIBUTED BROADCAST Everywhere Several Fundamental Computations Exemplified 4669573

15 A 30 a 18-POINT GOTHIC EXTRA CONDENSED \$3.70
BOLTESMANAZ AND CROSSMANERISM Exaggerated Ginfingers Flopperism 3725

10 A 20 a 24-POINT GOTHIC EXTRA CONDENSED \$3.30
SEVERAL AMUSING WONDERS Episodes Accumulating 374

6 A 12 a 30-POINT GOTHIC EXTRA CONDENSED \$3.65
HERMAN MENSONER Jake Leucoplastides 374

6 A 12 a 36-POINT GOTHIC EXTRA CONDENSED \$4.90
THEY HAD BEEN Bought and Resold 56

5 A 10 a 48-POINT GOTHIC EXTRA CONDENSED \$5.45
THE PRESS is Painted Dark Blue 56

5 A 8 a 60-POINT GOTHIC EXTRA CONDENSED \$6.55
75 ORIGINAL Schoolchildren

4 A 6 a 72-POINT GOTHIC EXTRA CONDENSED \$7.65
PLEASANT Sleighing 38

GOTHIC ITALIC No. 1.

24 A 50 a 8-POINT GOTHIC ITALIC No. 1 \$2.10

AS THE RIVER VANISHES FROM SIGHT WE ARE LOST IN THE CROWD
467 Your Train Slows Within the Vast and Mysterious Structures of a Very Sleepy Town 534

20 A 40 a 10-POINT GOTHIC ITALIC No. 1 \$2.15

SPIRITUAL GRAVITATION IS TERRIBLE AS LOST COURAGE
32 Irresistible as Possible and Men Fly to its Centers at the Dead of Night 48

15 A 30 a 12-POINT GOTHIC ITALIC No. 1 \$1.90

THE NIGHT USUALLY MADE HER LOOK PRETTY
752 Marguerite Began to Bang and Crimp Her Nut Brown Hair 346

12 A 25 a 16-POINT GOTHIC ITALIC No. 1 \$2.45

THE COMFORTS AND HAPPINESS OF MAN
432 Private Musical Instructions Given At Academy 875

10 A 20 a 20-POINT GOTHIC ITALIC No. 1 \$3.15

PULL HER HAIR WITH GRIM
5 Resolution Her Mother Came And Went 7

8 A 15 a 24-POINT GOTHIC ITALIC No. 1 \$3.50

KNOCKED AT HER DOOR
The American Athletic Society 19

GOTHIC No. 5.

24 A 50 a 5-POINT GOTHIC No. 5 \$2.95
SEARCHING FOR GRANDEUR
Working Patriotically For Appearances

20 A 40 a 8-POINT GOTHIC No. 5 \$2.60
DRIPPING BEAUTY
Dusky Wings and Whiskers

12 A 25 a 12-POINT GOTHIC No. 5 \$2.80
HONOURED
Unknown Countries

24 A 50 a 6-POINT GOTHIC No. 5 \$2.65
SEARCH FOR CHARLIE
Christmas and Holiday Dramatist

15 A 30 a 10-POINT GOTHIC No. 5 \$2.50
SHAKESPEARE
Marine Band Concerts

9 A 18 a 18-POINT GOTHIC No. 5 \$3.10
THE BOYS
Arabian Foundry

6 A 12 a 20-POINT GOTHIC No. 5 \$2.80
LITTLE TOM Greens Luck 5

6 A 12 a 24-POINT GOTHIC No. 5 \$4.00
5 Chicago or KANSAS

5 A 10 a 30-POINT GOTHIC No. 5 \$5.35
FINEST Printing 6

5 A 8 a 36-POINT GOTHIC No. 5 \$6.80
George BRAD 4

4 A 8 a 42-POINT GOTHIC No. 5 \$8.00
3 THE Suburb

4 A 6 a 48-POINT GOTHIC No. 5 \$9.50
Court YET 1

GOTHIC No. 9.

24 A 50 a 6-POINT GOTHIC No. 9 \$2.05
THE RAILWAY AND MARINE
Insurance Companies State of California 35

24 A 50 a 8-POINT GOTHIC No. 9 \$2.00
AMERICAN COUNTRIES
51 The United States of North America

12 A 25 a 12-POINT GOTHIC No. 9 \$2.30
REGULATIONS
Discount to the Trade 23

15 A 30 a 10-POINT GOTHIC No. 9 \$2.05
BOILED CHICKEN
Extra Fine Dinners Served 23

10 A 20 a 18-POINT GOTHIC No. 9 \$3.35

MERRY CHRISTMAS
31 Santa Claus Going his Rounds 14

8 A 15 a 20-POINT GOTHIC No. 9 \$3.60

GENTLE MAIDEN
Douglas and Garfield Parks 87

6 A 12 a 24-POINT GOTHIC No. 9 \$4.25

DEPARTMENT
32 Printers Specimens

5 A 10 a 36-POINT GOTHIC No. 9 \$6.60

ORIGINAL
Steam Engines 5

5 A 8 a 48-POINT GOTHIC No. 9 \$9.25

RANGE
Gothic Series

DEARBORN AND INITIALS.

24-POINT INITIALS. 3A, \$1.50

12-POINT DEARBORN

15A, \$2.10

THE OAKLAND EXODUS
FLIGHT OF CRANKS TO ALTURASBURG
WEAK BRAINS ON EARLY TRAINS

36-POINT INITIALS. 3A, \$2.50

18-POINT DEARBORN

8A, \$2.60

POOR HUMANITY
UNBALANCED MENTALITY
RELIGIOUS INSANITY

WIDE LINING GOTHIC.

30A 6-POINT WIDE L. GOTHIC No. 20 \$1.30

OUR DAILIES TEEM WITH
DARING DEEDS, AND BOOKS ARE
FILLED WITH FAME.

30A 6-POINT WIDE L. GOTHIC No. 21 \$1.60

BRASS BANDS WILL PLAY
AND CANNONS ROAR LOUD
HONOR TO

30A 6-POINT WIDE L. GOTHIC No. 22 \$1.75

THE NAME OF MEN
WHO HELD COMMISSIONS
AND WERE

30A 6-POINT WIDE L. GOTHIC No. 23 \$1.95

HONEST, BRAVE AND
TRUE; & YET THE QUERY
COMES TO ME

20 A

8-POINT WIDE LINING GOTHIC

\$1.80

WHAT DID THE PRIVATES DO?
WHO WERE THE MEN TO GUARD THE
CAMP WHEN THE FOES

15 A

10-POINT WIDE LINING GOTHIC

\$1.75

WERE HOVERING
ROUND? OR DUG THE GRAVES
⇒ OF COMRADES DEAR ⇐

15 A

12-POINT WIDE LINING GOTHIC

\$2.20

⇒ AND LAID ⇐
THEM IN THE GROUND?

DORMER SERIES.

6 A 12 a

18-POINT DORMER

\$2.50

Numerous Flat Irons and Rolling Pins
Eighteen or Twenty Months after the Honeymoon 78

4 A 8 a

30-POINT DORMER

\$3.15

Columbus Exhibition
Accident Insurance Policy Company 35

HAZEL SCRIPT.

9 A 30 a

14-POINT HAZEL SCRIPT

\$5.50

*A Popular Man must be Easy and Affable,
And never do anything Clownish nor Laughable; must
live without Friction, be plain in his Diction, and like a
Good Fellow pay up his Subscription.*

9 A 25 a

18-POINT HAZEL SCRIPT

\$6.40

*The weary Brain will Plot and Plan
Some Way of Duty Shirking: It's Queer how
Hard a Lazy Man
will work to Keep from Working!*

\$ 1234567890

7 A 20 a

24-POINT HAZEL SCRIPT

\$8.00

*Keep Your Eye on This.
Hazel Script Distances all Others.*

STEELPLATE TEXT.

6 A 14 a

18-POINT STEELPLATE TEXT

\$3.35

Rochester Somerville Company
Importers Wholesale and Retail Dealers 98

5 A 10 a

24-POINT STEELPLATE TEXT

\$3.85

Revenue Department
67 The National Supply Company

4 A 8 a

30-POINT STEELPLATE TEXT

\$4.45

Copper and Brass
Gold and Silver Mines 23

FREAK SERIES.

12 A 25 a 10-POINT FREAK \$2.75

‡Shadow and Sunshine‡
The †Darktown †Fire †Brigade 3

5 A 10 a 24-POINT FREAK \$3.95

Beautiful
Grain †Basket 8

9 A 18 a 12-POINT FREAK \$2.85

‡Splendid Music‡
Central †Opera †House †5

6 A 12 a 18-POINT FREAK \$3.35

‡Discontent‡
Annual †Struggle †2

4 A 8 a

30-POINT FREAK

\$4.50

Christmas †Decorations †46

LITHOTYPE ORNAMENTS.

(INTERCHANGABLE) PRICE \$15.00

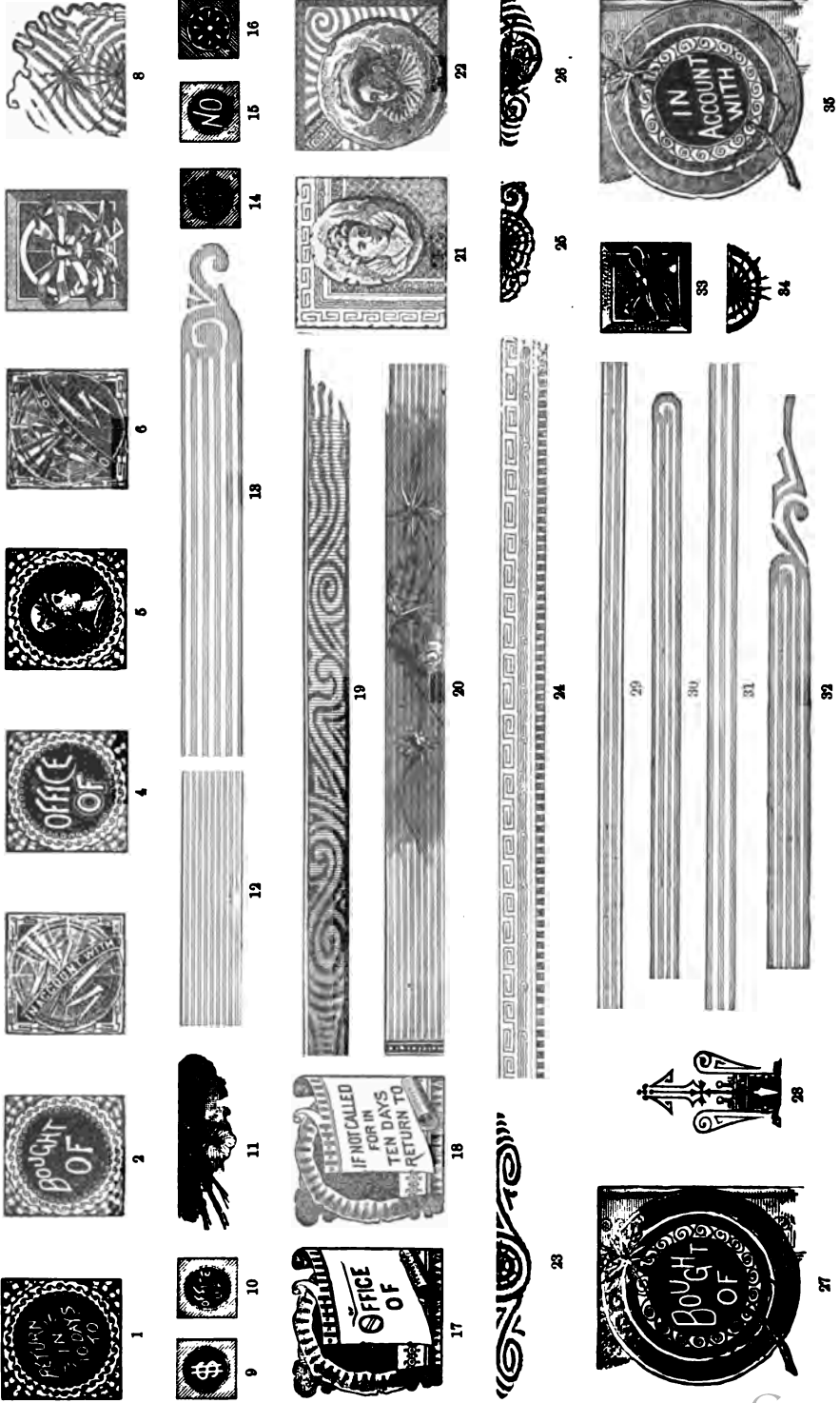

Hawks & Shattuck, San Francisco.

LITHOTYPE ORNAMENTS.

ON THE POINT SYSTEM.



36



37



38



39



40



41



42



43



44



45



46



47



48



49



50



51



52



53



54

HURON SERIES.

15 A 30 a 8-POINT HURON \$2.00
SCHOOL BOYS ABROAD
Elegant Piecture from Petersburg 2

8 A 15 a 18-POINT HURON \$2.95
MIDGETS
3 Orange Groves

12 A 25 a 10-POINT HURON \$2.00
DAYS OF YOUTH
5 Convicted and Sentenced

10 A 20 a 12-POINT HURON \$2.00
PERFECTION
Musical People Silent 4

6 A 10 a 24-POINT HURON \$3.35
ENGLISH Postal Clerks 3

COLGATE SERIES.

15 A 20 a 10-POINT COLGATE \$1.80
THE NATIONAL CONVENTION
87 Was Held in Chicago October the Eighth

6 A 10 a 24-POINT COLGATE \$3.15
ENGRAVINGS
7 Summer Clothings

12 A 18 a 12-POINT COLGATE \$2.15
DANCING AND SKATING
The Roller Skating Rink Carnival 5

10 A 15 a 18-POINT COLGATE \$2.95
UNCERTAINTIES
Bright Sunday Mornings 2

5 A 8 a 30-POINT COLGATE \$3.30
38 Riches are Only BORN OF TOIL

5 A 8 a 36-POINT COLGATE \$4.50
GENERAL Telegraph Office 4

ARCADE.

30 A	6-POINT ARCADE No. 1	\$1 60
THOUGHTS AND LANGUAGES ACT AND REACT UPON EACH OTHER 456789		
25 A	6-POINT ARCADE No. 2	\$1 75
THE PRIZE CANNOT BE OBTAINED WITHOUT LABOR 54		
20 A	9-POINT ARCADE	\$2 00
CAMELS WALK THROUGH THE 345		
15 A	12-POINT ARCADE	\$2 50
213 HESPERIAN CLIMATE		
10 A	18-POINT ARCADE	\$3 25
RESPECT WAS 58		
8 A	24-POINT ARCADE	\$4 00
67 PERSIANS		

CLEMATIS.

10 A 25 a	12-POINT CLEMATIS.	\$2.75
GRINDEST AND MOST SOBER		
Display of Chromos and Statuary of Great and Ancient Masters		
983 The Stars Shine Brightly Above 493		
8 A 20 a	18-POINT CLEMATIS.	\$3.85
MORRISON AND BUTTERWORTH		
Elegant Pictures of Siege of Paris on Exhibition		
34 Slow but Always Sure 65		
6 A 14 a	24-POINT CLEMATIS.	\$4.95
MODERN AND ANCIENT		
Those Beautiful Bells Ring Sweetly		
45 When for the Best 67		

BREVET.

10 A 20 a

12-POINT BREVET.

\$2 00

BULLER AND GRIM AROSE THE SUN

Another Pensive Cockroach who Now has Told his Sorrows

364 Twenty Pious and Funny Pugilists 578

8 A 16 a

18-POINT BREVET

\$3 75

BORN PROUD AND RICH

The Fastidious People of Egypt and Europe

5 A 10 a

24-POINT BREVET

\$3 65

POOR BUT HONEST

Are Practicing Political Economy

4 A 6 a

36-POINT BREVET

\$4 55

FAIR MAIDENS

Opera of Barber of Seville

ELITE.

10 A 25 a

12-POINT ELITE.

\$2.60

UPRIGHT AND HONEST CONGRESSMEN

The Biggest and Most Stupendous Humbugs Under the Political System

85 Represent Nobody But Themselves 76

8 A 20 a

18-POINT ELITE.

\$3.65

BOODLERS AND OTHER MUSICIANS

Vessels Plying the Northern Rivers Frequently Pass

6 A 14 a

24-POINT ELITE.

\$4.05

SWEETLY AND PRETTILY

Jove Himself Held the Gavel and Galled the

Hawks & Shattuck, San Francisco.

Digitized by Google

CHARTER.

10 A 15 a

12-POINT CHARTER

\$3 05

LAUGHING COQUETTISH MAIDEN

Twenty Eight Hundred Thousand People 24

8 A 12 a

18-POINT CHARTER

\$4 60

KENTUCKY FARMS

Michigan and Lake Superior 52

6 A 10 a

24-POINT CHARTER

\$5 40

CIRCULARS

34 The Charter Series

CADENCE.

10 A 25 a

12-POINT CADENCE.

\$2.80

MAHOGANY BLACK WALNUT AND ROSEWOOD

Drawing Room Furniture Received Thursday Afternoon August 23 1789

8 A 20 a

18-POINT CADENCE.

\$3.80

BORN PROUD AND RICH

65 Large Wholesale And Retail Carpet Department

6 A 14 a

24-POINT CADENCE.

\$4.95

PRINTERS BONANZA

4 Unloading all Freight From the Elevator

SUPERIOR.

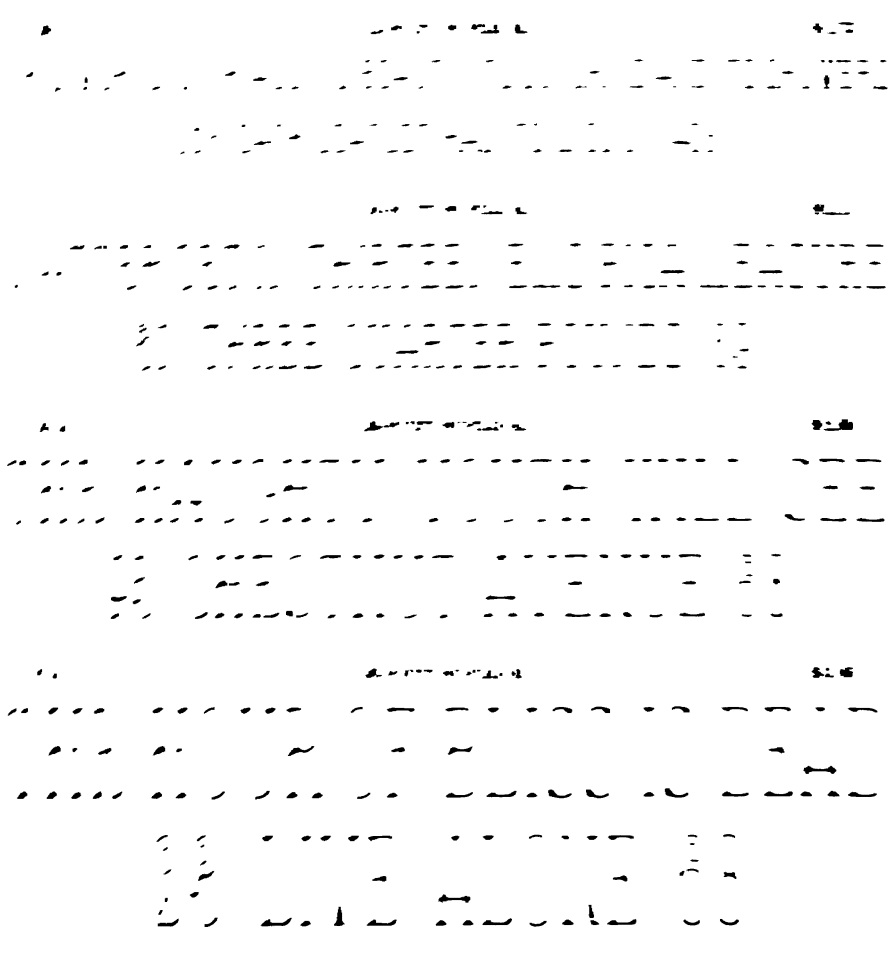

OCCIDENT SHADED.

- | | | |
|---|--------------------------------|--------|
| W.A. WA | 24 FIRST OCCIDENT SHADED No. 2 | \$3.20 |
| THE EMBLEM OF TRUTH & AMERICAN FREEDOM | | |
| W.A. WA | 24 FIRST OCCIDENT SHADED No. 2 | \$3.50 |
| HARK! THE HERALD ANGELS SING GLORY 34 | | |
| W.A. WA | 24 FIRST OCCIDENT SHADED No. 2 | \$4.00 |
| FOREIGN ADVENTURERS AND SNOBS! | | |

ACME.

15 A 20 a 6-POINT ACME. \$2.40

APPARENTLY NOT SATISFIED THEREWITH
Alligator Family are now Manufacturers of Fancy Leather Goods
76 Monkey Skin their Latest Novelty 50

12 A 18 a 8-POINT ACME. \$2.70

FLORIDA MOSS IS BEING INTRODUCED
Into the Manufacture of Paper It is a More Valuable
25 Product to the State 76

10 A 15 a 10-POINT ACME. \$2.60

HERE LIES BILLY CROPPET
Who Gauged a Ball But Could not Stop it Far Down
53 The Field he Chased the Fly 46

8 A 12 a 12-POINT ACME. \$2.90

THE BASE BALL PARK
Eighteen Hundred and Eighty Eighth
324 The Diamond Green 348

6 A 10 a 18-POINT ACME. \$3.90

JANUARY THE FIRST
Type Setting Tournaments
Eighteen Eighty 87

CLEFT GOTHIC.

12 A 10-POINT CLEFT GOTHIC. \$1.40

MANY PORTIONS OF THE ROCKY ROADS
78 EMERALDO PLAINS 26

10 A 12-POINT CLEFT GOTHIC. \$1.50

MANY ROCKY MOUNTAIN ROADS
75 STEEP AND HIGH 38

8 A 18-POINT CLEFT GOTHIC. \$2.00

THE CHICAGO BASE BALL
34 GROUNDS 57

CAPRICE.

20 A	10-POINT CAPRICE	\$1 60
34	THE + AMERICAN + FLORISTS' + JOURNAL	
16 A	12-POINT CAPRICE	\$1 65
84	EIGHT ÷ ELEGANT ÷ PICTURES	
10 A	18-POINT CAPRICE	\$2 40
	CARBON ÷ PENCILS ÷ 34	
8 A	24-POINT CAPRICE	\$3 30
62	DARK NIGHTS	
6 A	30-POINT CAPRICE	\$4 10
9	AMERICAN	
5 A	36-POINT CAPRICE	\$4 40
5	CARBON	
4 A	48-POINT CAPRICE	\$7 30
4	SPRING	

CABINET.

10 A 20 a	12-POINT CABINET	\$3 20
	UNITED STATES OF AMERICA	
	Large Furniture Manufacturer in the Dominion of Canada	42
6 A 14 a	18-POINT CABINET	\$3 75
	JANUARY THE FIRST	
	National Convention of Brazilian States	2
5 A 10 a	24-POINT CABINET	\$4 50
	GOVERNMENT	
	The United States Ministers	58

YALE.

10 A

24-POINT YALE.

\$2.00

LONGFELLOW'S + DISASTERS 57

8 A

30-POINT YALE.

\$2.55

48 CLIMATE + OF + ASIA 8

6 A

36-POINT YALE.

\$2.65

PRINTERS' + SUPPLIES 76

5 A

42-POINT YALE.

\$2.95

63 ENGLISH + PEOPLE

5 A

48-POINT YALE.

\$4.00

PLUSH + CAPES 3

STEEL PLATE.

12 A

12-POINT STEEL PLATE.

\$3.20

FLANDSOMOR SUPERB PLATE 3

10 A

18-POINT STEEL PLATE.

\$4.00

ELEGANCE SUPERB

8 A

36-POINT STEEL PLATE.

\$4.80

STARRY NIGHTS 8

LIBRARY

ENGLISH OPERA COMPANY
2 SHERMAN HOUSE 7

A MORNING RANGER
78 FLOWERS 34

CORAL ROCKS
4 PAINTS 9

ECLIPSE SHADED NO. 2.

HUDSONS & BROWNELLS
76 Birds go Singing 67

DENVER & OMAHA
Hard Storms 78

WET & COLD
Eastern 3

Hobbs & Sutcliffe, San Francisco

OLD STYLE LATIN CONDENSED.

PATENTED.

OLD STYLE AND LINING FIGURES WITH EACH FONT.

25 A, \$1.30. 40 a, \$1.15. 12 POINT OLD STYLE LATIN CONDENSED. \$2.45

MY HUNGRY HEART WAS ALMOST IN MY MOUTH

The Little Lambs were Numerous and Needed Constant Care and Attention

1234567890 Old Style and Lining Figures 1234567890

20 A, \$1.90. 30 a, \$1.50. 18 POINT OLD STYLE LATIN CONDENSED. \$3.40

ROUND THE RUGGED ROCKS THE RAGGED RASCAL RAN

Snivil Slervice Reform as She is Practiced

12 A, \$1.95. 20 a, \$1.70. 24 POINT OLD STYLE LATIN CONDENSED. \$3.65

INCONSISTENCIES OF SPOIL DISTRIBUTERS

Reduction of Uncle Sam's Surplus

8 A, \$2.10. 12 a, \$1.70. 36 POINT OLD STYLE LATIN CONDENSED. \$3.80

Gossamer Garments for Summer Use

PERSPIRATION DEMOLISHERS

5 A, \$2.10. 10 a, \$2.05. 40 POINT OLD STYLE LATIN CONDENSED. \$4.15

Schooner Contentment Ashore

LONESOME ROCKERIES

5 A, \$2.70. 8 a, \$2.15. 48 POINT OLD STYLE LATIN CONDENSED. \$4.85

Slender Brazilian Cocoanut

Hawks & Shattuck, San Francisco.

APOLLO.

22 A 16 a 8-POINT APOLLO \$3.00

A SMALL BOY WITH A SHINING PAIL WENT GAILY

Singing Down the Dale to Where the Cow with Brindle Tail on the Sweet Clover
did Regale. The Bumble Bee did

14 A 32 a 10-POINT APOLLO \$3.25

GAILY SAIL OVER THE SOFT AND SHADOWY

Yale to where the Boy with the Shining Pail was Milking the
Cow with the Brindle Tail

14 A 30 a 12-POINT APOLLO \$3.50

THE BEE LIT DOWN ON THE COW'S

Left Ear her Heels Flew up Through the Atmosphere
and Through the Leaves

10 A 20 a 18-POINT APOLLO \$4.00

OF THE WALNUT TREE

The Boy Soared into Eternity Amen
\$125,400

RACINE CIRCULAR.

32 A 60 a 6-POINT RACINE CIRCULAR \$3.40

OH THE CLOTHES PRESS IS A SWELL AFFAIR FOR

Garments Nice and Neat. The Hay Press is a Grand Machine and Does its Work
Complete. The Cider Press is Lovely

30 A 50 a 8-POINT RACINE CIRCULAR \$3.75

WITH ITS JUICES RED AND SWEET

But the Printing Press Controls the World and Gets There With
Both Feet. \$137,369.00

25 A 40 a 10-POINT RACINE CIRCULAR \$4.10

THE MAN WHO CHEATS HIS PRINTER

Out of a Single Cent Never Reaches the Better Land
Where Old Elijah Went

24 A 36 a 12-POINT RACINE CIRCULAR \$4.70

HE'LL NEVER MEET A

Pleasant Face Or See One Festive Grin His
Only Chance for Happiness Will Be
Almighty Thin

Hawks & Shattuck, San Francisco.

HAZLETT.

8 A 40 a

12-POINT HAZLETT

\$4.40

*Tell me not in Mournful Numbers
Advertising does not Pay 'Tis the matter you Compile
Sir That Must Have its Powerful Sway Print
the Truth and State it*

6 A 40 a

18-POINT HAZLETT

\$5.50

*Strong sir Surely then you'll Live to
Tell Advertising is the Lever Which Bring
239 Trade so Plentiful 146*

INCLINED LINING GOTHIC.

40 A	6-POINT INCLINED LINING GOTHIC No. 4	\$1.30
THE AMERICAN MISSIONARY ASSOCIATION TO BENEFIT THE UNEDUCATED HEATHENS 486789		
40 A	6-POINT INCLINED LINING GOTHIC No. 5	\$1.55
479 JOHN BENJAMIN JAMES BINGFORD BANKS GOES TO ARGENTINE CONFEDERATION		
40 A	6-POINT INCLINED LINING GOTHIC No. 6	\$1.75
THE CALIFORNIA RELIEF AND AID SOCIETY LEFT FOR PENNSYLVANIA 273		
40 A	6-POINT INCLINED LINING GOTHIC No. 7	\$1.85
56 THE GREAT EASTERN COMBINATION TRUST IS NEARING IT'S END		
30 A	8-POINT INCLINED LINING GOTHIC	\$1.85
THE NORTH EASTERN STEEL AND IRON COMPANY 345		
20 A	10-POINT INCLINED LINING GOTHIC	\$1.65
89 INCLINED GOTHIC SURE TO WEAR WELL		
20 A	12-POINT INCLINED LINING GOTHIC	\$2.10
5 AMERICAN ARTISTIC PRINTERS		

REMINGTON.

20 A 100 a

12-POINT REMINGTON No. 2

\$7.00

This font is cast on uniform body, and contains uniform spaces. The face has been cut as a fac simile of the type used on Remington Type Writer No. 2.

Hawks & Shattuck, San Francisco.

ALDEN.

PATENTED.

12 A, \$1.00

10 POINT ALDEN.

30 a, \$1.00. \$2.00

12345 THE METROPOLIS CHOWDER SOCIETY 67890

Valuable Collection of Interesting Relics, Trophies and Mementos from European Countries
First Series of Complete Performances of Wagner's Celebrated Operas.

BOSTON MUSEUM OF HISTORY

10 A, \$1.15

12 POINT ALDEN.

25 a, \$1.25. \$2.40

∴ EXTRAORDINARY : FIELD : ENGAGEMENTS ∴

Grand Realistic Panorama of the Battles Fought During the Rebellion
Chicago, Rock Island and Pacific Railroad Company

73 EDUCATIONAL INSTITUTIONS 56

8 A, \$1.65

18 POINT ALDEN.

20 a, \$1.75. \$3.40

Special Departure in all our Departments
Wonderful Inducements to Part With Your Collateral

40 ARTISTIC EXHIBITION 28

10 A, \$2.55

24 POINT ALDEN.

15 a, \$1.90. \$4.45

Game Laws for New York State
Rules and Regulations Governing Their Sale

28 BOSTON JOURNAL 40

Hawks & Shattuck, San Francisco.

GOTHICS, 8, 9 & 10.

☞ LINING FIGURES WITH EACH FONT. ☞

40 A, \$1.45. 50 a, \$0.85 6 POINT GOTHIC No. 8. \$2.30

PURCHASE YOUR TYPE FROM LEGITIMATE TYPE FOUNDERS AND SAVE MONEY

Everything Pertaining to the Art of Typography can be Purchased Direct in Well-Regulated Type Foundries
12345 Box up your Old Type Metal and send to us for New Material 67890

40 A 6 POINT GOTHIC No. 9. \$1.00

AMERICAN FOUNDRIES PRODUCE SOME OF THE MOST ELABORATE AND BEAUTIFUL DESIGNS IN TYPE, BORDERS AND BRASS RULE
12345 TO BE FOUND IN THE WORLD. SEND FOR OUR CATALOGUES 67890

40 A 6 POINT GOTHIC, No. 10. \$1.15

THE PHILOSOPHICAL OPINION OF ORGANIC NATURE; A POPULAR EXPOSITION OF THE POINTS OF HUMAN
12345 PHYLOGENY; THE EVOLUTION OF MAN AS KNOWN TO SCIENCE 67890
MARCHING MAUNCHING MARCHING

30 A, \$1.50. 50 a, \$1.25 8 POINT GOTHIC No. 8. \$2.75

THE INDUSTRIAL ARTS AMONG THE ORIENTAL NATIONS

Designs in Borders, Colored Initials, Weather Signals, Card Pipes and State Arms

40 A 8 POINT GOTHIC No. 9. \$1.00

THRILLING AND BLOOD CURDLING STORIES OF THE EARLY SETTLERS OF MANHATTANVILLE, HARLEM
HOODLUMS HUNTING THE ODORIFEROUS ROCK CLIMBING GOAT
COMMERCIAL RELATIONS

25 A, \$1.30. 40 a, \$1.20 10 POINT GOTHIC No. 8. \$2.50

WORK OF MERIT AND THRILLING INTEREST

The Geography, History and Resources of the Western Country

25 A 10 POINT GOTHIC No. 9. \$1.00

THE ILLUMINATED HANDBOOK OF PRACTICAL AND MECHANICAL ENGINEERING
READY-MADE GRANITE ROCK DRILLED TO ORDER
LIGHT SUMMER READING

20 A, \$1.50. 30 a, \$1.15 12 POINT GOTHIC No. 8 \$2.65

POSSIBLE OVERLAND ROUTE TO EUROPE

Tremendous Exodus of Summer Commercial Drummers

20 A 12 POINT GOTHIC No. 9. \$1.00

NOTHING IS SO EASY AND INVITING AS THE RETORT OF SARCASM
A KEEN REPROACHFUL EXPRESSION STINGS
DISCOURTEOUS REMARKS

Hawks & Shattuck, San Francisco.

CURVED GOTHIC.

PATENTED.

15 a 10 A 18 POINT CURVED GOTHIC. \$3.25

12 a 8 A 24 POINT CURVED GOTHIC. \$4.75

Numerous Fine Engravings

Doctor Saint Leon

12 MAGAZINE 34

12 MUSIC 90

10 a 6 A

36 POINT CURVED GOTHIC.

\$5.75

Landing MEATS AT Plymouth

CURVED GOTHIC SHADED.

PATENTED.

10 A 15 a

18 POINT CURVED GOTHIC SHADED.

\$3.50

Before the Period of the Renaissance A. D. 1849

8 A 12 a

24 POINT CURVED GOTHIC SHADED.

\$4.75

Heliotypes of Photo-Zinc Engraving

6 A 10 a

36 POINT CURVED GOTHIC SHADED.

\$6.35

Popular 2 STATE 8 History

CURVED ANTIQUE.

PATENTED.

15 a 10 A 18 POINT CURVED ANTIQUE. \$3.40

12 a 8 A 24 POINT CURVED ANTIQUE. \$4.75

International Exhibition

Conscience Proof

18 INSTITUTE 76

18 GIRLS 63

10 a 6 A

36 POINT CURVED ANTIQUE.

\$6.20

Illustrated GOLDEN Nations

6 a 4 A

48 POINT CURVED ANTIQUE.

\$7.75

Modern CAN Border

ANTIQUE No. 300.

25 A \$1.25

5 POINT ANTIQUE No. 300.

40 a \$1.10

\$2.35

The Official Figures of Texas' area are 252,896 square miles; equal to about Eight and Nine-tenths per cent. of the entire area of the United States and Territories; and **SIX TIMES LARGER THAN NEW YORK AND TAMMANY HALL.**

25 A, \$1.55

6 POINT ANTIQUE No. 300.

40 a, \$1.25.

\$2.80

In Mercantile affairs Punctuality is as important as in Military. Thousands remain poor all their lives who, if they were more faithful to their word **WOULD SECURE A LARGE RUN OF CUSTOM.**

25 A, \$1.55

8 POINT ANTIQUE No. 300.

40 a, \$1.25.

\$2.80

You have no right to waste the Time of other People. If you are behind time fulfilling an engagement, you may cause **OTHERS TO BREAK THEIR ENGAGEMENTS.**

20 A, \$1.90

10 POINT ANTIQUE No. 300.

40 a, \$1.55.

\$3.45

Be very careful in making any Agreements But when you once agree stick to the terms of agreement **NO MATTER WHAT HAPPENS.**

15 A, \$1.15

12 POINT ANTIQUE No. 300.

30 a, \$1.40.

\$2.55

Lemonade made from the juice of a Lemon Is one of the best and safest drinks for any person **EXCEPT FIRST-CLASS BRANDY.**

10 A, \$1.65

18 POINT ANTIQUE No. 300.

15 a, \$1.40.

\$3.05

What Contemptible Hogs Authority will make of some men **TAKE NOTICE**

5 A 10 a

24 POINT ANTIQUE No. 300.

\$4.00

Our Modern Resources
2 SUPERIOR 8

Hawks & Shattuck, San Francisco.

WASHINGTON.

22A 32a 6-POINT WASHINGTON \$2.25

HEY DIDDLE DIDDLE!

Uncle Sam in the Middle, Now Congress will
Organize Soon,

18A 24a 8-POINT WASHINGTON \$2.50

THE SENATE AND HOUSE

Have their Annual Rows and Feed
from the National Spoon

16A 22a 10-POINT WASHINGTON \$2.75

LOBBY MEMOIRS

Tales of a Greenback at the
American Headquarters

12A 18a 12-POINT WASHINGTON \$3.00

THE CAPITOL

The National Museums
The Patent Building

9A 13a 18-POINT WASHINGTON \$3.50

STAUNCH

United American

8A 10a 24-POINT WASHINGTON \$4.50

Great Nation

6A 8a 30-POINT WASHINGTON \$5.25

The Senate

5A 7a 36-POINT WASHINGTON \$6.75

Diplomat

4A 6a

42-POINT WASHINGTON

\$7.25

Potomac River

4A 5a

48-POINT WASHINGTON

\$10.00

White 8 House

4A 5a

54-POINT WASHINGTON

\$10.50

Pan Handle

4A 5a

60-POINT WASHINGTON

\$15.00

The Dome

JEFFERSON.

26 A 38 a 6-POINT JEFFERSON \$2.25

SHE WAS FULL OF CUNNING CRINKLES,
Little Tricks and Wily Wrinkles, to Catch Crabs and Periwinkles in the

10 A 14 a 18-POINT JEFFERSON \$3.25

DAY She Knew All the

24 A 32 a 8-POINT JEFFERSON \$2.50

WATERS OF THE BAY
A Modest little lady She Believed in keeping Shady

8 A 10 a 24-POINT JEFFERSON \$4.50

Leading Jobbers

20 A 28 a 10-POINT JEFFERSON \$2.75

AND SHE CERTAINLY
Earned a Reputation for the Way She

6 A 8 a 30-POINT JEFFERSON \$4.75

In Fish Tackle

16 A 24 a 12-POINT JEFFERSON \$3.00

HANDLED MEN AND
Arguments and Always Won The

5 A 7 a 36-POINT JEFFERSON \$5.75

REELS and

4 A 6 a

42-POINT JEFFERSON

\$6.25

Bobbers She Always

4 A 6 a

48-POINT JEFFERSON

\$7.75

Got those Robbers

4 A 5 a

54-POINT JEFFERSON

\$8.50

Who would Steal

4 A 5 a

60-POINT JEFFERSON

\$11.00

Her Bait Away

LAFAYETTE.

20 A 30 a 12-POINT LAFAYETTE \$ 3.00 9 A 12 a 30-POINT LAFAYETTE \$ 5.00

**SHE COULD SEE WITHOUT
Her Glasses how to Hook the Trout and**

Her Wily Skill Only

12 A 18 a 18-POINT LAFAYETTE \$ 3.25

Basses and She Gathered in

8 A 10 a 36-POINT LAFAYETTE \$ 5.75

10 A 14 a 24-POINT LAFAYETTE \$ 4.00

By Masses Victims of

One Thing Was

6 A 9 a

42-POINT LAFAYETTE

\$ 6.25

The Matter She Could Fish

6 A 8 a

48-POINT LAFAYETTE

\$ 7.00

But Couldn't Flatter and

4 A 6 a

54-POINT LAFAYETTE

\$ 7.00

That Made the Young

4 A 6 a

60-POINT LAFAYETTE

\$ 7.50

Men Scatter so She'd

4 A 5 a

72-POINT LAFAYETTE

\$ 9.50

Never Fill the Bill

ELZEVIR.

- 30 A 20 A 100 a 8 POINT ELZEVIR \$4.05
ONCE UPON A MAY MORN DREARY
She was Working Weak and Weary Down Upon Her Marrows Mopping
12345 MOPPING UP THE PARLOR FLOOR 67890
- 25 A 20 A 75 a 10-POINT ELZEVIR \$4.05
WHILE THE MOP WENT FLIPPING FLAPPING
Suddenly She Heard a Tapping, Tapping at the Parlor Door. 'Tis Some
23 Visitor, She Muttered, TAPPING AT THE PARLOR DOOR 64
- 25 A 20 A 65 a 12-POINT ELZEVIR \$4.80
GRACIOUS PETER! WHAT A BORE!
Up She Jumped and nearly Swearing Hastily began Preparing
12345 TO APPEAR AS WOMEN WISH TO 67890
- 20 A 10 A 50 a 14-POINT ELZEVIR \$4.90
WHEN THEIR CALLERS
Look Them o'er; Yanked Her Apron off and Slung it,
80 SNATCHED HER 96
- 12 A 20 a 20-POINT ELZEVIR \$4.15
HEADGEAR OFF AND
Flung it, Grabbed a Dolman up and
7 Hung it o'er the Greasy 8
- 10 A 15 a 24-POINT ELZEVIR \$4.50
GOWN SHE WORE
Then She Found a Plaguey
- 6 A 10 a 36-POINT ELZEVIR \$6.25
PEDDLER
Standing at the Door
- 5 A 5 a 48-POINT ELZEVIR \$7.75
Nothing More 4

CHALLENGE.

25 A 40 a 6-PT. CHALLENGE \$3.25

WHOLESALE AND RETAIL

*Most Fashionable Black Rosewood
June 23 1887*

20 A 30 a 9-POINT CHALLENGE \$3.75

THE DOOLITTLE

*Stationary Steam Engine
1428 Market*

15 A 25 a 12-POINT CHALLENGE \$4.25

IMPORTERS

*Dealer in Medicine
746 Etc*

10 A 15 a 18-POINT CHALLENGE \$4.50

PAPERS

James Florn

6 A 10 a 24-POINT CHALLENGE \$5.75

STARS

Gone easy

4 A 6 a 36-POINT CHALLENGE \$7.00

ASK

Bodies!

4 A 5 a 48-POINT CHALLENGE \$9.00

TAR

Hphg

LIGHTFACE CHALLENGE.

25 A 40 a 6-PT. L. CHALLENGE \$3.25

WIDE SOFT DUSKY WINGS

*Upon The Dry and Sapless Trees
One Thousand Crows*

20 A 30 a 9-PT. L. CHALLENGE \$3.75

PLEASE EVERYONE

*Sounds Heard Over Hills
and Dales*

15 A 25 a 12-PT. L. CHALLENGE \$4.25

BORN PROUD

*Unknown Country
Treasure*

10 A 15 a 18-PT. L. CHALLENGE \$4.50

ORGAN

Ocean Forest

6 A 10 a 24-PT. L. CHALLENGE \$5.75

RANGE

Land Test

4 A 6 a 36-PT. L. CHALLENGE \$7.00

BOG

Trotters

4 A 5 a 48-PT. L. CHALLENGE \$9.00

NO

Dates

CONCAVE.

30 A 6-POINT CONCAVE \$1.35
READINGS FROM SHAKSPEARE
EIGHTEENTH CENTURY DRAMATISTS
HOLIDAY BOOKS 1887

25 A 10-POINT CONCAVE \$1.65
ENGLISH ODES
WONDERS NEVER CEASE
108329

18 A 12-POINT CONCAVE \$1.70
QUOTATIONS
PRINCESS MEDLEY
6587

15 A 18-POINT CONCAVE \$2.55
SENATOR
BLUE ROOMS
4534

10 A 24-POINT CONCAVE \$3.35
BEND
ROPEMIN
56

6 A 36-POINT CONCAVE \$4.15
STERM
NO 1

5 A 42-POINT CONCAVE \$4.80
REED
12

DOTTED.

20 A 12-POINT DOTTED \$1.40
MEMENTO OF OUR
NATIONAL LIBERTY ODE
54 POETS 83

15 A 18-POINT DOTTED \$2.10
CORMORANTS
DIFFIDENT YOUTH
5334

10 A 24-POINT DOTTED \$2.50
AUBURN
DOTTIE ELLIS
63

8 A 30-POINT DOTTED \$2.90
HAIRSER
STEREOPE
4846

6 A 36-POINT DOTTED \$3.80
DUST
PEANUT
NO 3

ASTEROID.

15 A 25 a 12-POINT ASTEROID \$2.75

THE CROWDED AUDITORIUM

With all the Elite and Aristocratic Kickers

Increase the Wonder 272

10 A 15 a 18-POINT ASTEROID \$3.00

LARGE SOCIETIES

Denouncing the Legislatures

Withdrew 342

8 A 12 a 24-POINT ASTEROID \$3.60

MOVEMENT

The Human Existence

An Explanation 29

6 A 10 a 30-POINT ASTEROID \$4.15

SHOWN THEREIN

Days of 40

5 A 8 a 36-POINT ASTEROID \$4.80

ADVERTISER

Cometh 34

EMPIRE.

15 a 25 a 12-POINT EMPIRE \$2.75

UNITED STATES TREASURY

Traveler Riding Through Gorgeous

Mountain Scenery

10 A 15 a 18-POINT EMPIRE \$3.60

PRUSSIAN MARKET

The Star of the Morning

8 Generously 9

8 A 12 a 24-POINT EMPIRE \$4.40

ARTISTIC

A Golden Necklace

Our Neighbors

5 A 8 a 36-POINT EMPIRE \$5.50

INDIAN

Sobr Industry

New World

CALUMET.

12 A 12-POINT CALUMET \$1.95

FIFTY THOUSAND

8 A 18-POINT CALUMET \$2.50

HUNDRED ALL

6 A 24-POINT CALUMET \$3.20

CHICAGO

SPENSER.

24 1 12-POINT SPENSER \$2.00

POLITE SOCIETY
INTELLIGENT AMERICANS
567 «ON-THE» 234

15 1 1-POINT SPENSER \$2.25

DRIPPINGS
SAN FRANCISCO
6 «IN-ART» 4

10 1 24-POINT SPENSER \$2.50

GROWN
THE MARINE
5 «A-L» 6

4 1 20-POINT SPENSER \$3.25

SHOUT
C-STREET
2 «AND» 3

6 1 20-POINT SPENSER \$4.00

STERN
IN :: TIME
«3 :: S»

VICTOR.

24 1 20-POINT VICTOR \$3.70

PIZADOR
Bull Ring Acrobats
«18 ~ 93»

4 1 12-POINT VICTOR \$4.65

SPOILS
To the Victor
«3 and»

5 1 24-POINT VICTOR \$5.40

«GOD»
Wom Gohn
? and 8

PANSY.

15 1 12-POINT PANSY \$2.15

ONLY A PANSY
Blossom Only a little Bud
457

6 1 10-POINT PANSY \$2.65

STYGIAN
Timorous Mortals

5 1 24-POINT PANSY \$3.75

Old Red Barn
HI SPY

ANTIQUÉ EXTENDED No. 5.

15 A 30 a

6-POINT ANTIQUÉ EXTENDED No. 5

\$2.85

HOW FRESH TO MY MIND
Are the Scenes of my Childhood when fond
8 Recollections 4

12 A 25 a

8-POINT ANTIQUÉ EXTENDED No. 5

\$3.25

PRESENT THEM TO VIEW
The Cow-stall, the Pig-pen, the ten
5 Cords of Firewood 6

9 A 18 a

10-POINT ANTIQUÉ EXTENDED No. 5

\$3.10

AND ALL
The Tough Chores which I
had to go through

6 A 12 a

12-POINT ANTIQUÉ EXTENDED No. 5

\$2.85

THE WEEDS IN
The Garden, Stones
in the Stubble

5 A 10 a

18-POINT ANTIQUÉ EXTENDED No. 5

\$4.15

ERRANDS
Run and White
Beans Sold.

4 A 8 a

24-POINT ANTIQUÉ EXTENDED No. 5

\$5.40

BOOKS
Badger Den
1890

LATIN CONDENSED.

- | | | |
|---|--------------------------|---------|
| 24 A 50 a | 12-POINT LATIN CONDENSED | \$2.50 |
| RELIABLE FOOD FOR THE CAPTAINS OF THE CITY HALL | | |
| Anarchists Food for the Perfection and Growth of the Infants in Minnesota 2345678 | | |
| 15 A 30 a | 18-POINT LATIN CONDENSED | \$2.75 |
| SUBSTANTIAL ANCIENT SETTLEMENT | | |
| Episodes in the Lives of Produce Brokers at Bunker Hill 568 | | |
| 12 A 25 a | 24-POINT LATIN CONDENSED | \$3.80 |
| POSTMASTER HORNSWAGGLE | | |
| Largest and Most Stupendous Political Men 243 | | |
| 6 A 12 a | 36-POINT LATIN CONDENSED | \$4.25 |
| THE HOMES BEYOND | | |
| Remedy for the Smoke Nuisance 4 | | |
| 5 A 10 a | 48-POINT LATIN CONDENSED | \$5.55 |
| CLOTHING HOUSE | | |
| 826 Permanent as Niagara | | |
| 4 A 8 a | 60-POINT LATIN CONDENSED | \$9.00 |
| 2 National Convention | | |
| 4 A 5 a | 72-POINT LATIN CONDENSED | \$10.75 |
| Royal Bulgarian 5 | | |

LIGHTFACE CELTIC.

5 A 10 a

30-POINT LIGHTFACE CELTIC

\$4.80

BILL DAD

The Scribe is a Good
Man if Asleep

5 A 8 a

30-POINT LIGHTFACE CELTIC

\$6.95

HOT CAKE

Makes Butter
Fly Like 60

4 A 6 a

48-POINT LIGHTFACE CELTIC

\$9.50

ECHO

Touch Not
1890

STANDARD SCRIPT.

9 A 25 a

18-POINT STANDARD SCRIPT

\$6.00

*Obliging Printing and Stationery Company
Chicago Rock Island and Pacific Railroad Yards
Saturday Evening July 23d 1887*

7 A 20 a

24-POINT STANDARD SCRIPT

\$8.00

*Young Ladies Fither Club
Hudson River Steamboat Companies
138 to 176 East Indiana Avenue*

5 A 15 a

36-POINT STANDARD SCRIPT

\$10.00

*Bond and Note Dealer
Saturday, October 24th, 1897*

4 A 10 a

48-POINT STANDARD SCRIPT

\$12.00

*Pay James E Dale
Seven Hundred 53*

PRICES INCLUDE SPACES AND QUADS.

Hawks & Shattuck, San Francisco.

MYRTLE SCRIPT.

12 A 80 a \$9.00

18-POINT MYRTLE SCRIPT

6 A 40 a \$5.00

Miss Beautiful Myrtle Script

*Thursday Afternoon and Evening November the twenty third
1887 Eighteen hundred and Eighty Seven 1887*

10 A 60 a \$11.25

24-POINT MYRTLE SCRIPT

5 A 30 a \$6.00

Printers Furnishing Warehouse

*Hawks & Shattuck San Francisco California
23 Type Cases Stands Presses Etc. 56*

ARTISTIC SCRIPT.

7 A 20 a

24-POINT ARTISTIC SCRIPT

\$7.00

The Artistic Script Series

*Have a care of what you say and more of what you do
San Francisco California October 23, 1887*

GRACE SCRIPT.

5 A 15 a \$6.80

30-POINT GRACE SCRIPT

4 A 10 a \$4.25

15 a Small Lower Case \$3.50

Mr. and Mrs. Grace Script

request your presence at the marriage of their daughter

Myrtle to G. P. Lakeside,

At their residence Friday, December sixteenth.

Hawks & Shattuck, San Francisco.

PRINCESS SCRIPT.

16 A 80 a \$7.50

12-POINT PRINCESS SCRIPT

8 A 40 a \$4.00

Uniforms and Outfits for Military and Naval Officers
Mahogany Black Walnut and Rosewood Drawing Room Furniture
Received Thursday Afternoon June 29th 1887

12 A 80 a \$10.00

18-POINT PRINCESS SCRIPT

6 A 40 a \$5.50

Ornamental Tree and Flower Association
Importers and Wholesale Dealers in English French and
German Medicines Drugs Perfumery Etc 2543
There comes a Time when even Grief grows Weary, and
Eyes for want of Tears must Close

10 A 60 a \$12.00

24-POINT PRINCESS SCRIPT

5 A 30 a \$6.50

At Home to all the World
Drop in and Enjoy Our Glorious Climate
Family Matinee every Wednesday
Stationary Steam Engine and Boiler Works

BELLE SCRIPT.

4 A 24 a

24-POINT BELLE SCRIPT NO. 2

\$7.50

Evangeline Mahaffy and James Fairweight
Married
Brooklyn, Wednesday, Sept. 1, 1854.

Hawks & Shattuck, San Francisco.

LAKESIDE SCRIPT.

16 A 80 a \$10.00

12-POINT LAKESIDE SCRIPT

8 A 40 a \$5.25

The Unprecedented success which followed the
Appearance of my Double Pica has induced my Manufacturers
To present me in Diminished body and face 2345

12 A 60 a \$10.25

18-POINT LAKESIDE SCRIPT

6 A 30 a \$5.50

Those who have criticised me say I grow
More beautiful as my face becomes smaller and that
I will be never so useful as in my Present Size 35

8 A 40 a \$11.50

24-POINT LAKESIDE SCRIPT

4 A 20 a \$5.75

Admirers of the Beautiful
Will surely Order me Because of my
3 Durability and Adaptability 5

6 A 20 a \$11.50

36-POINT LAKESIDE SCRIPT

3 A 10 a \$6.00

For Executing very
Fine Circular Printing Yours
Lakeside Script 2534

LEGAL ITALIC.

25 A 150 a

8-POINT LEGAL ITALIC

\$5.00

*MY FIDDLE? WALL, I KIND O' KEEP HER HANDY, DON'T YE KNOW,
Though I ain't so much inclined to tromp the strings and switch the bow, as I was before
the timber of my elbows got so dry, and my fingers was more limber like and caperish
and spry. Yet I can plunk and plink, and tune her up and play, and jest lean back
and laugh and wink at every rainy day.*

20 A 115 a

10-POINT LEGAL ITALIC

\$5.10

*MY PLAYIN'S ONLY MIDDLIN; TUNES I PICKED
Up when a boy. The kind o' sort o' fiddlin' that the folks call Cor-
duroy. "The Old Fat Gal" and "Ryestraw" and "My Sailor's on the
Sea," is the cowntillions that I saw when the choice is left to me. And
so I plink and plonk and plunk and rosum up my bow, and play the
tunes that make you think the Devil's in your toe!*

*Nickel-faced Leaders to match in 5-lb founts kept in stock,
and furnished at 56 cents per pound.*

Brass Leaders \$1.50 per pound.

15 A 80 a

12-POINT LEGAL ITALIC

\$4.45

*THAT'S HOW THIS DEAR OLD FIDDLE
Won my heart's enduring love, from the strings across her
middle to the screechin' keys above. From her Apron, over
Bridge, to the ribbon round her Throat, she's a wooin', coo-
in' pigeon, singin' Love Me every note! And so I pat her
neck and plink her strings with lorin' hands, and listening
close I sometimes think she kind o' understands.*

*Nickel-faced Leaders to match in 5-lb founts kept
in stock and furnished at 52 cents per pound.*

Brass Leaders \$1.35 per pound.

LEAFLET BORDERS.

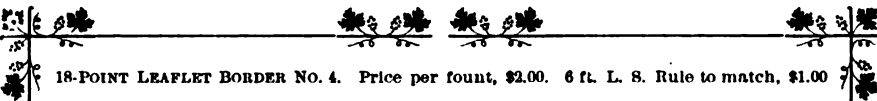
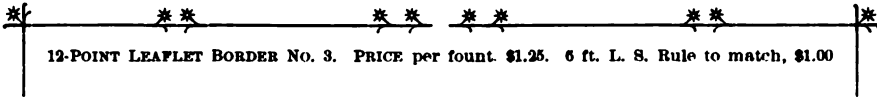
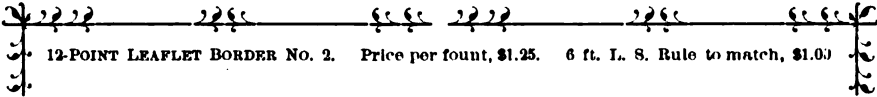
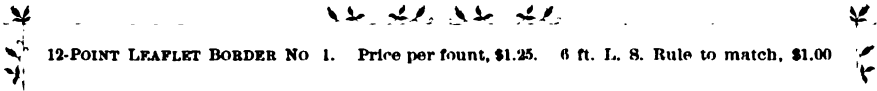

CATTLE BRANDS.

No. 1. .25



No. 2. .25



No. 3. .25



No. 4. .25

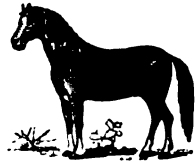

WEATHER SIGNALS.

Adopted March 1, 1887, by the Signal Service Offices at Washington.

24-POINT WEATHER SIGNALS. Price per fount, 75 cents

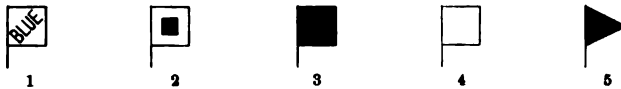

48-POINT WEATHER SIGNALS. Price per fount, \$1.00

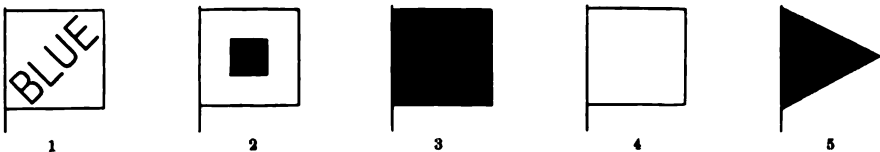

If desired to have Flag No. 1 represented in its proper color (blue), No. 3 may be used in its place.

PHISTS.

D8221 .40



D8223 .40



D8213 .20



D8214 .20



D8218 .60



D8220 .60



D8217 .90



D694 \$1.00



D8215 .90

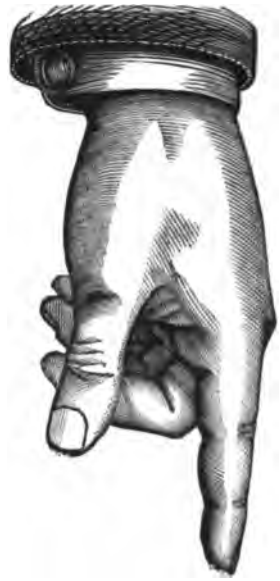

Z1297 \$1.50



MORTICED CUTS.

Z4266 \$1.00

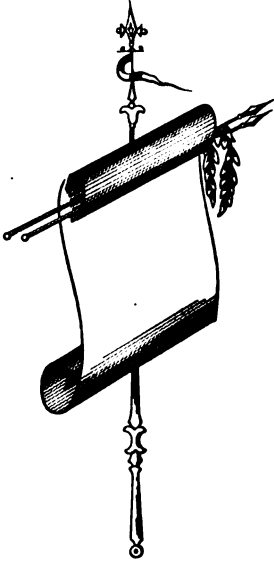

Z1278 .50

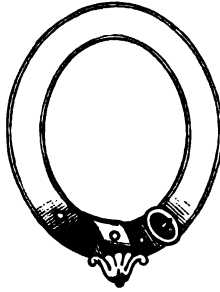

Z3349 .75



Z1413 .90

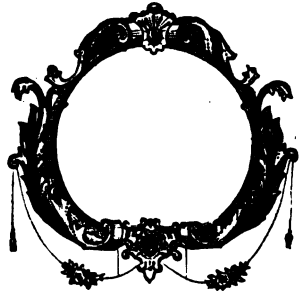

Z5183 .75

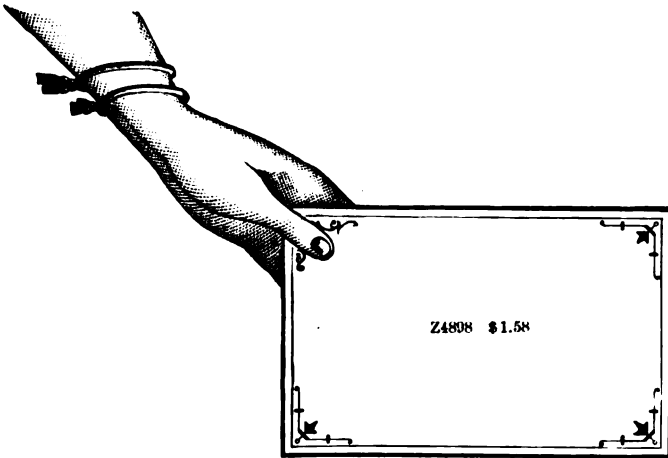

Z4980 \$25

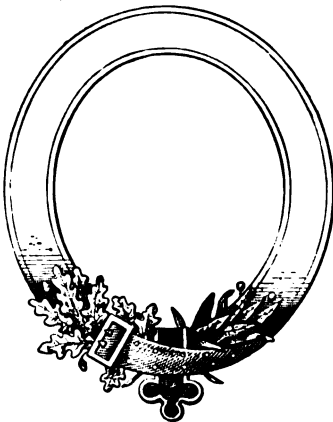

Z4807 .60

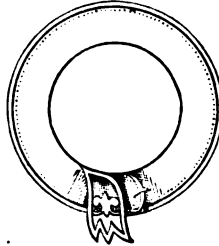

Z215 .60

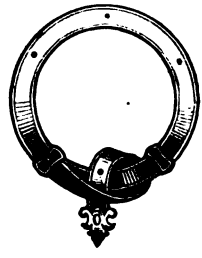

Z3354 .40



Z4379 .30



ATLANTA.

20 A	8-POINT ATLANTA.	\$2.50
DAYS+OF+OLD+THE+DAYS+OF+BEANS+AND+PORK		
16 A	10-POINT ATLANTA.	\$2.75
SHERMAN'S+MARCH+TO+THE+SEA		
12 A	12-POINT ATLANTA.	\$3.00
PURPLE+TINTS+OF+EVENING		
9 A	14-POINT ATLANTA.	\$3.25
SUPERIOR+MENAGERIES		
8 A	18-POINT ATLANTA.	\$3.50
MONKEY+PARROT		
6 A	24-POINT ATLANTA.	\$4.50
FINER+ROSES		
4 A	36-POINT ATLANTA.	\$6.75
SPARKER		

MANUSCRIPT.

10 A 40 a	18-POINT MANUSCRIPT.	\$6.00
<i>Manuscript from the City of Culture and Beans.</i>		
6 A 24 a	24-POINT MANUSCRIPT.	\$7.00
<i>Phelps, Dalton & Co. Dickinson Foundry</i>		

BANK CHEQUE SHADED.

4 A 10 a	36-POINT BANK CHEQUE SHADED.	\$6.00
North American Saving Banks		
72 Diploma 50		

Hawks & Shattuck, San Francisco.

COMBINATION GOTHIC ITALIC.

- 40 A 6-POINT COMBINATION GOTHIC ITALIC No. 31 \$1.35
*OLD GAFFER'S SON I WILL NOT WED, AND DON'T FORGET IT! LOUD SHE SAID. SHOULD EVERY LIVING
CREATURE DIE, AND NONE BE LEFT BUT JIM AND I, I WOULD NOT WED OLD GAFFER'S SON*
- 30 A 6-POINT COMBINATION GOTHIC ITALIC No. 32 \$1.35
*THE BOW-LEGGED WALL-EYED SON OF A GUN! THE SWAN, SHE SAID, THE LAKE'S CLEAR
BREAST MAY BARTER FOR THE GROUND-HOG'S NEST; THE AWE'S*
- 24 A 12-POINT COMBINATION GOTHIC ITALIC No. 33 \$1.40
*FIERCE STREAM MAY BACKWARD TURN, THE GOOD PRIEST YELL, MAY I BE
DURN! BUT I, WERE ALL THOSE MARVELS DONE, WOULD NEVER*
- 20 A 12-POINT COMBINATION GOTHIC ITALIC No. 34 \$1.40
*WED OLD GAFFER'S SON, THE KNOCK-KNEED, LOP-EARED SON
OF A GUN! STILL WHERE THE BULL*
- 16 A 12-POINT COMBINATION GOTHIC ITALIC No. 35 \$1.40
*FROG LAYS HER EGGS; THE SWAN STILL LAVES
HER PURPLE LEGS; STILL DOWNWARD*
- 14 A 18-POINT COMBINATION GOTHIC ITALIC No. 36 \$2.00
*FLOWS THE AWE'S SWEET RIVER, AND
WILL, NO DOUBT THUS FLOW FOR*
- 10 A 24-POINT COMBINATION GOTHIC ITALIC No. 37 \$2.25
*EVER; BUT NORA'S HEART IS
LOST AND WON*
- 8 A 24-POINT COMBINATION GOTHIC ITALIC No. 38 \$2.50
*SHE'S WEDDED TO OLD
7 GAFFER'S SON 7*
- 6 A 36-POINT COMBINATION GOTHIC ITALIC No. 49 \$3.40
AND THEY HAD 7
- 4 A 48-POINT COMBINATION GOTHIC ITALIC No. 50 \$4.00
CHILDREN! 12

AURORAL NO. 2.

10 A 18 a

12-POINT AURORAL No. 2.

\$4.55

AN INDEPENDENT MAN
Why Don't Gallagher Let Her Go Cairo
The Newspaper Man of 1890

8 A 14 a

18-POINT AURORAL No. 2.

\$6.05

BANQUO'S GHOST
Autumn Woods Gold and Red
123 Mystic Blending 456

6 A 10 a

24-POINT AURORAL No. 2.

\$7.25

KIND WORDS
The Child of Slander 7

4 A 6 a

36-POINT AURORAL No. 2.

\$9.70

MAIDENS
Cupid's Song 2

SANTA CLAUS.

6 A 20 a, with ornaments

18-POINT SANTA CLAUS.

\$4.00

A · MERRY · CHRISTMAS!
Children · dear, · Your · eyes · are · opened · wide
To See The Good Saint Nicholas
1889 ER HE TH NG ND 1890

SANTA CLAUS BORDER.

\$2.00



Hawks & Shattuck, San Francisco.

NORMAN ITALIC.

28 A 70 a 8-POINT NORMAN ITALIC. \$ 2.75 24 A 62 a 10 POINT NORMAN ITALIC. \$ 8.25

WESTERN CATTLE BREEDERS HAPPY FASHIONABLE EXCURSIONISTS
Large Sales Being Shipped 46 Daily Many Point Interest Visited
Wonderful Increase Over Previous Years Returning Home 135 Well Pleased

28 A 16 a 82 a 12-POINT NORMAN ITALIC \$ 2.96

SHE WAS YOUNG, SHE WAS GAY, AND SHE PARTED HER
167 Hair Like the Average Belle, in the Middle 450

8 A 12 a 16 a 18-POINT NORMAN ITALIC. \$ 4.38

IT WAS AN OLD SAILOR WHO SAID HE NEVER
Saw Sharks Cry, but saw Whales Blubber 75

6 A 8 a 26 a 24-POINT NORMAN ITALIC. \$ 4.38

PRETTIEST TYPE FOR CIRCULARS
21 Score One for the Founder 93

6 A 5 a 10 a DOUBLE ENGLISH NORMAN ITALIC. \$ 5.25

SPRING OPENING OF 43 SUITS
Fast Trotting 57 Beacon Park

JAGGED SERIES.

18 A 12-POINT JAGGED No. 41. \$ 1.75

NOW DOTH THE LITTLE ONION POP UP HIS LITTLE HEAD NO 123
AND THE RESTLESS LITTLE RADISH

14 A 12-POINT JAGGED No. 40. \$ 1.75

STRETCH IN HIS LITTLE BED. THE SUNFISH AND THE
MINNOW * WAG * THEIR * SHINY * LITTLE * TAILS

12 A 12-POINT JAGGED No. 39. \$ 1.75

WHILE THE CHIPMUNK AND THE ROBIN * ADORN
2 * THE * FENCE * RAILS * 3 *

JAGGED SERIES DISPLAYED IN COMBINATION.

BOOK LARNIN IS A GOOD THING TO A MAN UP A TREE

Hawks & Shattuck, San Francisco.

QUAINT OPEN.

24 A

8-POINT QUAINT OPEN.

\$1.90

THE GREATEST BIRD TO FOIGHT, SAYS FAT, BARRING THE
AIGLE, IS THE DUCK; HE HAS A FOINE LARGE BILL

20 A

10-POINT QUAINT OPEN.

\$1.90

TO PECK, AND PLENTY OF RALE IRISH FLUCK. AND
THEN DO YE MOIND THE PUT HE HAS?

14 A

12-POINT QUAINT OPEN.

\$1.90

FULL AS BROAD OVER AS A CUP; SHOW
ME △ THE △ FOWL △ UPON △ TWO △ LEGS

10 A

18-POINT QUAINT OPEN.

\$2.25

THAT'S ABLE FUR TO THRIIP 23
HIM UP. AND RIGHT WAS HE

8 A

24 POINT QUAINT OPEN.

\$2.90

WILLIE △ NYE △ AND △ SAMMY
DAVIS BAD BOYS 2

6 A

36-POINT QUAINT OPEN.

\$3.40

2 SAD EXAMPLES 2

4 A

48-POINT QUAINT OPEN.

\$4.00

TAKE △ WARNIN

QUAINT.

24 A

8-POINT QUAINT.

\$1.90

BENEATH A SHADY TREE THEY SAT, HE HELD HER HAND
123 SHE HELD HIS HAT, I HELD MY BREATH AND LAY

20 A

10-POINT QUAINT.

\$1.90

RIGHT FLAT; THEY KISSED, I SAW THEM DO IT. HE
HELD : THAT : KISSING : WAS : NO

14 A

12-POINT QUAINT.

\$1.90

CRIME, SHE HELD HER HEAD UP EVERY 49
^TIME, I HELD MY PEACE AND^

10 A

18-POINT QUAINT.

\$2.25

WROTE : THIS : RHYME, : WHILE : 75
THEY THOUGHT

8 A

24-POINT QUAINT.

\$2.90

NO ONE KNEW IT. WHAT
JOY WAS THERE 76

6 A

36-POINT QUAINT.

\$3.40

OH MY COUNTRY 4

4 A

48-POINT QUAINT.

\$4.00

GRAND SERIES

GLADIATE.

14 A 24 A

10-POINT GLADIATE.

\$2.15

WHAT MADE THE CHIMNEY SWEEP?
AND WHY DID THE CODFISH BALL? AND WHY, O WHY DID THE PEANUT
STAND? AND WHO MAKES THE MORNING CALL? FICHERING.

12 A 18 A

12-POINT GLADIATE.

\$2.87

WHAT MADE THE MONKEY
WRENCH? OR WHY SHOULD THE OLD MILL DAM?
AND*WHO* DID*THE*SHOEMAKER*STRIKE? OR

8 A 12 A

18-POINT GLADIATE.

\$3.24

WHY DID THE RASPBERRY
JAM? WHY* DID*THE*ROLLER*SKATE?
WHY DID THE OYSTER FRY!

5 A 7 A

24 POINT GLADIATE.

\$4.48

—❖—ROME—❖—
THE*ARENIC*SCENES
GLADIATORIAL

4 A 3 A

36-POINT GLADIATE.

\$6.04

DICKINSON
PHELPS*DALTON
BOSTON

Hawks & Shattuck, San Francisco.

CRUSADER.

12 A

18-POINT CRUSADER No. 1.

\$2.00

UNCLE • SAM • GUARDS • HIS • FISHPOND

10 A

18-POINT CRUSADER No. 2.

\$2.25

HIGHEST • ARTIPODEAN • JINKS

8 A

24-POINT CRUSADER.

\$2.50

• GOT • HIS • BEHRINGS •

6 A

30-POINT CRUSADER.

\$3.00

GO • IT • JONATHAN!

4 A

36-POINT CRUSADER.

\$3.50

STAY • THERE

4 A

42-POINT CRUSADER.

\$4.50

AMERICAN

4 A

48-POINT CRUSADER.

\$4.90

CRUISER!

Hawks & Shattuck, San Francisco.

COLONIAL.

24 A	12-POINT COLONIAL No. 1.	\$1.50
*THIS*SERIES*IS*WORTHY*YOUR*NOTICE*FOR*STYLE*AND*PRICE*		
20 A	12-POINT COLONIAL No. 2.	\$1.65
*JOHNNY*BULL*HAS*NEVER*RECOVERED*FROM*THAT*		
14 A	18-POINT COLONIAL.	\$1.80
AMERICAN*TEA*PARTY*IN*BOSTON*HARBOR		
10 A	24-POINT COLONIAL.	\$2.00
THOSE*TYPESETTING*CHAMPIONS		
8 A	30-POINT COLONIAL.	\$2.25
OCCASIONAL TYPOGRAPH		
6 A	36-POINT COLONIAL.	\$2.25
INDEPENDENCE*HALL		
4 A	48-POINT COLONIAL.	\$2.85
UNITED*COLONIES		

OUTING SERIES.

50 A	6-POINT OUTING No. 45.	\$1.50	30 A	6-POINT OUTING No. 43.	\$1.50
OF COURSE IT WAS A JIN FOR HIM TO JTICK A PIN IN THE			POINTED HOOK STICKING THROUGH. SO		
1234 IN THE CHAIR WHERE HIS PARENT 5678			BEHIND THE LOUNGE HE GOT 4		
OFTEN SAT, BUT HE DIDN'T THINK OF THAT, DIDN'T CARE			FOR HE THOUGHT HE'D RATHER NOT BE		
40 A	6-POINT OUTING No. 44.	\$1.50	20 A	6-POINT OUTING No. 42.	\$1.75
ON THE CUSHION SOFT *** FAT LAY HIS FATHER'S			AROUND WHEN THE PARENT 12		
SUNDAY HAT, AND HE KNEW 43			RAISED THE HAT AND UPON		
THAT HE'D NEVER STOP TO LOOK FOR THE TINY			THE PIN POINT SAT: JUDGMENT		
18 A	12-POINT OUTING No. 48.	\$1.75			
A BOSTON GIRL SAT POUTING BECAUSE SHE'D HAD NO					
16 A	12-POINT OUTING No. 47.	\$1.75			
OUTING, AND HER BROTHER WAS A SROUTING					
14 A	12-POINT OUTING No. 46.	\$2.00			
BUT THE MOTHER SAID A SPROUTING					

Complete Series on 6-point, \$6.00—12-point, \$5.00.

Hawks & Shattuck, San Francisco.

RENAISSANT.

12 A 20 a	10-POINT RENAISSANT.	\$2.80
* O • YOUTH • WITH • SMOOTH • SAND • PAPERED • PATE *		
The Night is Dark, the Hour is Late; * Why de You Linger on My Gate ?		
10 A 16 a	12-POINT RENAISSANT.	\$2.80
* I STAY TO HELP YOUR DAUGHTER *		
Hold • this • Gate • upon • its • Hinges • old; * Go in, Old Man, You're Catching * Cold.		
8 A 12 a	18-POINT RENAISSANT.	\$2.80
* THE OLD MAN SOUGHT *		
His • Little • Bed • and • on • it • laid • his • Patient • Head		
6 A 10 a	24-POINT RENAISSANT.	\$3.40
I * THINK * My * Gate * is * safe! He * said		
4 A 6 a	30-POINT RENAISSANT.	\$3.90
PRESERVE * Our * Specimens		
4 A 5 a	36-POINT RENAISSANT.	\$4.80
REFER * to * them * Often!		
3 A 4 a	48-POINT RENAISSANT.	\$5.65
Hewitt's * Clam * Box		

MOXON.

16 A	12-POINT MOXON.	\$1.54
* PAYS • YOUR • MONEY • & • TAKES • YOUR • CHOICE *		
14 A	14-POINT MOXON.	\$1.58
* WE • INVITE • THOSE • WHO • DON'T • LIKE *		
10 A	18-POINT MOXON.	\$1.88
* PATENT * OUTSIDE * CROW * TO *		
6 A	24-POINT MOXON.	\$1.98
TRY * HOME * PLAN * CHICKEN		

Hawks & Shattuck, San Francisco.

KARNAC.

12 A 28 a	8-POINT KARNAC.	\$2.80
Graduated • Scholars • Looking • for • Honest • Employment Making Expensive Arrangements \$245 July Fourth Annual Celebration		
10 A 24 a	10-POINT KARNAC.	\$2.80
Large • Redution • Roman • Candles • and • Torpedoes Amateur Squelling Contest 36 Thousand Sporting Men Excited		
8 A 20 a	12-POINT KARNAC.	\$3.80
Enterprising • Youthful • Americans Profitable Business Dealings 58 Investing Money		
6 A 12 a	18 POINT KARNAC.	\$3.40
Contract • Labor • 59 • Unsatisfactory		
5 A 10 a	24-POINT KARNAC.	\$3.75
Knowing • 28 • Young • Germans		
4 A 8 a	30-POINT KARNAC.	\$4.90
Evening • \$40 • Songsters		
3 A 5 a	36-POINT KARNAC.	\$4.90
Triple • 36 • Dances		

ÆSTHETIC.

8 A	16-POINT ÆSTHETIC.	\$1.80
VERERABLE • AND • DISTINGUISHED • MAN		
8 A	20-POINT ÆSTHETIC.	\$2.35
CHIPS • IN • ON • OUR • HOME • PLAN		
6 A	24-POINT ÆSTHETIC.	\$2.50
TOUCHSTONE • TO • AUDERY		
5 A	30-POINT ÆSTHETIC.	\$2.60
PARTHENIA'S INGOMAR		

Hawks & Shattuck, San Francisco.

ERA.

20 A 30 a 10-POINT ERA \$2 15

15 A 25 a 12-POINT ERA \$2 35

PLEASURE GROUNDS

GOVERNMENTS

Lawn Tennis and Foot Ball

Steamships of Australia

1234567890

1234567890

10 A 15 a

18-POINT ERA

\$3 10

NATIONAL SEMINARY

Christian Temperance Associations

8 A 12 a

24-POINT ERA

\$3 90

COMMISSIONERS

Merchants from Wisconsin

5 A 8 a

36-POINT ERA

\$5 20

UNION DEPOT

Passenger Station

4 A 6 a

48-POINT ERA

\$7 55

BUILDING

South African

BISQUE.

20 A \$1 10 10-PT. BISQUE No. 2 40 a \$1 20
HIGH STONE WALLS
Preventing the City's Destruction
1234567890

15 A \$1 10 12-PT. BISQUE No. 2 30 a \$1 20
CITY REAL ESTATE
Beldons Insurance Agency
1234567890

15 A \$1 85 18-PT. BISQUE No. 2 20 a \$1 35
REGIMENTS
The First and Second

12 A \$2 10 20-PT. BISQUE No. 2 18 a \$1 80
FURNISHING
Fancy Dry Goods

8 A \$3 65 36-PT. BISQUE No. 2 10 a \$2 30
LARGE
Field Glass

10 A \$2 25 24-PT. BISQUE No. 2 15 a \$1 90
HARBORS
English Coasts

6 A \$3 60

42-POINT BISQUE No. 2

8 a \$2 45

PRETTY Specimens

5 A \$4 10

48-POINT BISQUE No. 2

6 a \$2 70

Georgia SUGAR

5 A \$6 05

60-POINT BISQUE No. 2

5 a \$3 00

FRUIT Basket

4 A \$6 65

72-POINT BISQUE No. 2

5 a \$4 15

Rich MINES

WEST OLD STYLE.

5 A 8 a \$ 8 90

48-POINT WEST OLD STYLE.

NEWSPAPER HEADING, \$ 2 50

The Hungry Gulch Snorter.

4 A 5 a \$ 9 45

60-POINT WEST OLD STYLE.

NEWSPAPER HEADING, \$ 3 00

Sierra Madre Record.

3 A 4 a \$ 11 25

72-POINT WEST OLD STYLE.

NEWSPAPER HEADING, \$ 3 00

Quincy Nationalist.

Hawls & Shattuck, San Francisco.

O. S. TITLE EXTENDED.

5 A 8 a

24-POINT OLD STYLE TITLE EXTENDED.

\$4 30

**18 Fine Company
MILITIA**

4 A 6 a

36-POINT OLD STYLE TITLE EXTENDED.

\$7 00

**And 7 Feed
HAY**

3 A 5 a

48-POINT OLD STYLE TITLE EXTENDED.

\$9 00

Old Style

O. S. ATHENIAN EXTENDED.

5 A 10 a

24-POINT OLD STYLE ATHENIAN EXTENDED.

\$4 90

**Use New Faces
STYLE**

3 A 5 a

36-POINT OLD STYLE ATHENIAN EXTENDED.

\$7 50

**Per Ounce
PRICE**

3 A 5 a

48-POINT OLD STYLE ATHENIAN EXTENDED.

\$10 00

To Ride

UNIQUE BORDERS.

6-POINT BORDERS.

Founts of 5 feet, \$1 40.

Founts of 10 feet, \$2 60.

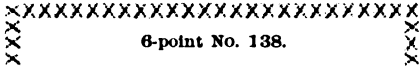

6-point No. 138.



6-point No. 139.

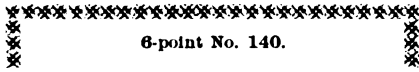

6-point No. 140.

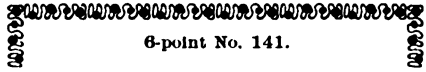

6-point No. 141.

12-POINT BORDERS.

Founts of 5 feet, \$1 60.

Founts of 10 feet, \$3 00.



12-point No. 166.

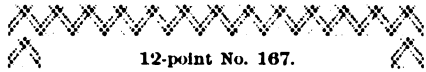

12-point No. 167.



12-point No. 168.



12-point No. 169.



12-point No. 172.



12-point No. 175.



12-Point No. 171.



12-Point No. 173.



12-point No. 176.

24-POINT BORDERS.

Founts of 3 feet, \$1 65.

Founts of 6 feet, \$3 00.

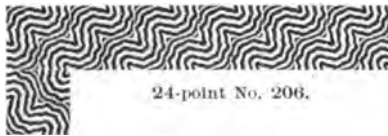

24-point No. 206.

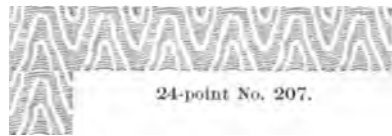

24-point No. 207.

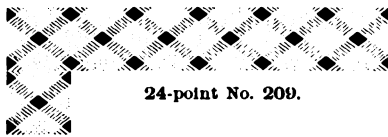

24-point No. 209.

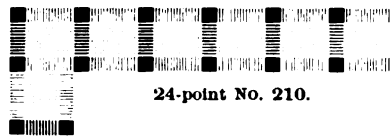

24-point No. 210.

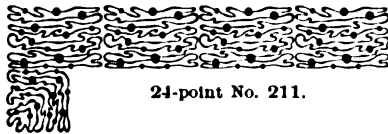

24-point No. 211.

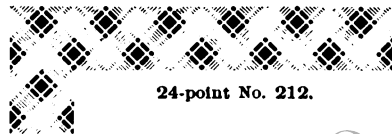

24-point No. 212.

NEW TRADE VICNETTES.

50 Cents Each.



No. 6123.—Lumber.



No. 6124.—Groceries.



No. 6125.—Confectionery.



No. 6126.—Dry Goods.



No. 6127.—Tailor.



No. 6129.—Drugs.



No. 6130.—Gen'l Mdse.



No. 6128.—Millinery.



No. 6131.—Jewelry.



No. 6132.—Books.



No. 6133.—Furniture.



No. 6136.—Clothing.



No. 6134.—Glassware.



No. 6137.—Tobacco.



No. 6135.—Hardware.

NEW TRADE VICNETTES.

50 Cents Each.



No. 6138.—Ag. Implements.



No. 6139.—Livery.



No. 6140.—Cigars.



No. 6141.—Boots and Shoes.



No. 6142.—Implements and Seeds.

NEW LOCOTYPES.



Z 6101 50c.



Z 6117 50c.



Z 6097 30c.



Z 6098 30c.



Z 6118 30c.



Z 6146 25c.



Z 6147 30c.



Z 6150 30c.



Z 6151 50c.



Z 6152 40c.



Z 6153 25c.



Z 6158 50c.



Z 6160 30c.



Z 6162 50c.

NEW LOGOTYPES.

TEN CENTS EACH.



FIFTEEN CENTS EACH.

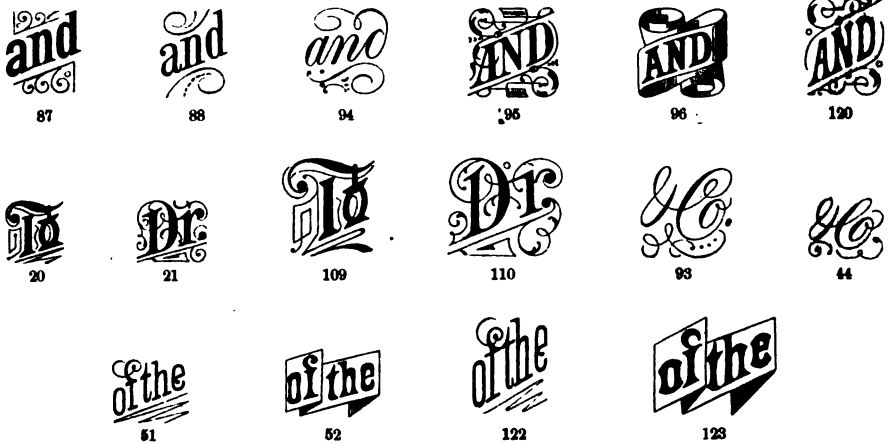

BROWNIES.

Price per fount, containing one character of each, \$2 00.

Single Characters: 1 to 9, 15 cents each; 10 to 19, 25 cents each.

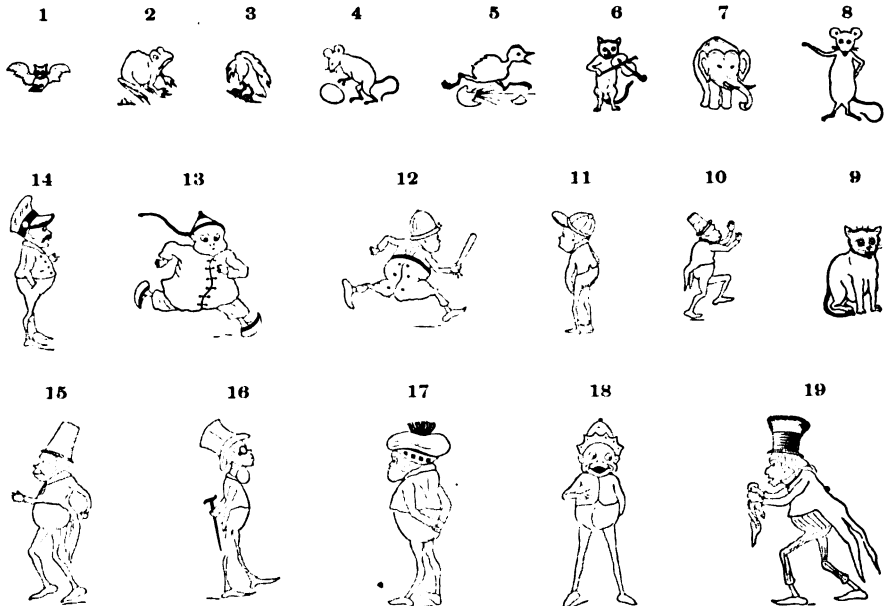

Hawks & Shattuck, San Francisco.

METROPOLIS ITALIC.

FIGURES WITH ALL FONTS.

PATENTED. CAST FROM SOLID COPPER MATRIX.

20 A, \$0.90. 75 a, \$1.75 6 POINT METROPOLIS ITALIC. \$2.85

ONION PARTIES HAVE BECOME FASHIONABLE IN KANADAH

Six Girls Stand in a Row while one Bites a Small Chunk out of an Onion and a Young Man Pays Ten Cents for a Guess as to which one it was. If he Guesses Right the Young Man Kisses the Other Five Ladies, if he Does Not he is only Allowed to kiss

12345 THE GIRL WITH THE ONION-SCENTED BREATH 67890

20 A, \$1.40. 80 a, \$1.70 8 POINT METROPOLIS ITALIC. \$3.10

ONCE UPON A TIME THERE WAS A FARMER

Who was much Annoyed by the Bad Habit a certain Wolf had of Eating his Sheep. The Farmer, Reasoned with him, and Even Offered to Pay for Having him Sent to a

SLAUGHTER HOUSE AND KILLED

20 A, \$1.60. 40a, \$1.55 10 POINT METROPOLIS ITALIC. \$3.15

DISSOLUTION OF PARTNERSHIP

On and after this date the Firm known as Distillery & Co. will close out their Business of Rum Manufacturers And open a New Morgue and Graveyard

ON THE PREMISES

20 A, \$1.85. 40 a, \$1.85 12 POINT METROPOLIS ITALIC. \$3.70

MODERN TERPSICOREAN BALLET

*Beautiful, Georgeously Abbreviated Chorus Costumes
Tent Life Behind the Scenes of Side Shows
Circus Rider's Frantic Efforts to*

JUMP SKY HIGH

Hawks & Shattuck, San Francisco.

ELZEVIR ITALIC.

28 A 80 a

10-POINT ELZEVIR ITALIC

\$3.80

THE KNIGHTS OF THE ROAD.

*Oh, Days of Old! Oh, Knights of Old! Oh, Times of Blood and Thunder
When Courage could be coined like Gold, and Gold seemed coined for Plun-
der! With Pistols and a tempered Sword, a Horse and silken Visor, a
Man might live like any Lord, and no one be the wiser.*

\$1234567890 QU Qu et es is as sp us

20 A 50 a

12-POINT ELZEVIR ITALIC

\$3.94

THE COACH DOOR OPEN WIDE

*You fling, "Your Purse, Watch, Diamond Buckles; Oblige
me with that Ruby Ring that Sparkles on your knuckles."*

*You knock the Post Boy from his ledge, you pocket all the
Treasure; Your good Horse leaps the Hawthorne Hedge, Then
bey for Town and Pleasure!*

\$1234567890 QU Qu et as es is us sp

SANSOM SCRIPT.

10 A 50 a

18-POINT SANSOM SCRIPT

\$9.30

See the Kit and the Cat

The Cat is the Dam of the Kit. Dam the Cat

Adieu! Adieu! My Native Land

*Our facilities for manufacturing Rushlights are unequalled
by anybody, and, as you are one of our intimate friends, we
offer you the privilege of taking an office in our dark cellar*

24-POINT, 10 A 50 a, \$12.50

36-POINT, 6 A 30 a, \$15.00

Hawks & Shattuck, San Francisco.

INSET CORNERS.

POINT SYSTEM.

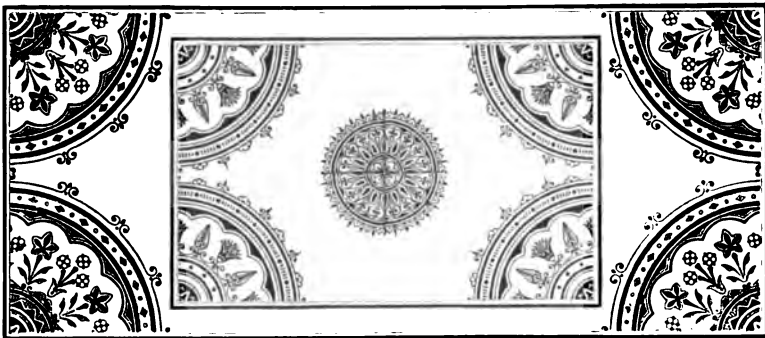
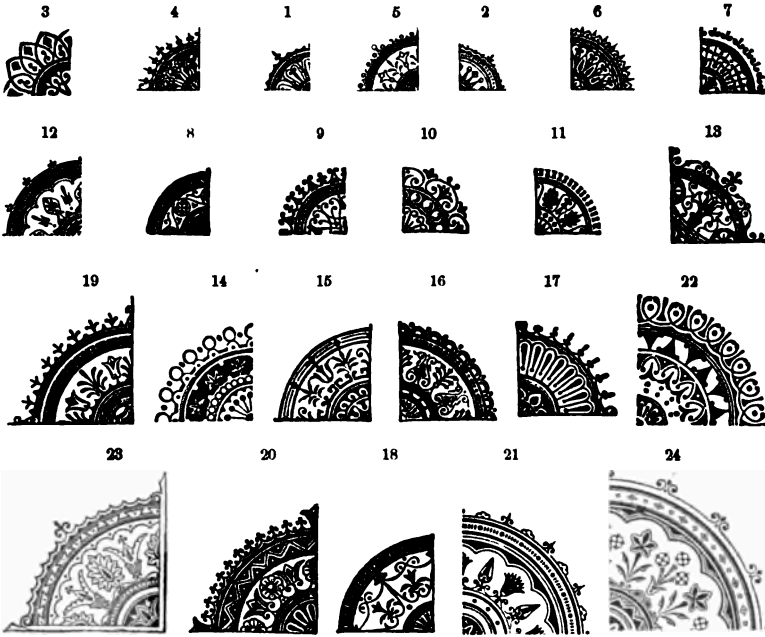

One Set consists of FOUR Corners. Nos. 1 and 2, 20 cts. per set; 3 to 11, 30 cts. per set; 12 to 18, 40 cts. per set; 19 to 21, 50 cts. per set; 22 to 24, 60 cts. per set.

DOTLET * ORNAMENTS

IN THREE SERIES.

Cast on Square 6 and 12 Point Bodies.

» SERIES ONE. \$1.00 «

1 2 3 4 5 6 7 8 9 10 11 12 13 14 15
 ◊ ◊ + × ◻ ◻ * ☆ ⊕ △ △ ◊ ◊ ◊

» SERIES THREE. \$1.25 «

1 2 3 4 5 6 7 8 9 10 11 12 13
 : ∴ ∴ ∴ * * * ∘ ∘ △ ◻ ◻ ◻ ∘ ⊕ ∘

14 15 16 17 18 19 20 21 22
 ☆ △ ◻ ◻ ◻ ◻ ◻ ◻ ◻ ◻ ◻ ◻ ◻

» SERIES TWO. \$1.00 «

1 2 3 4 5 6 7 8 9 10 11 12 13 14
 ▲ ▲ ■ ■ ◆ ◆ ◻ ⊕ ● ◆ ◻ : ∴ ∴

15 16 17 18 19 20
 ∴ * * ● ● ●

» SNOW FLAKE BORDER. «

Price, \$1.50.

1 2 3 4 5 6 7 8 1 2
 ●● * * * * * * * * ●● * *

Dotlet Ornaments, Series One and Two,
 36 of each character: Three, 18 of each
 character.
 Snowflake Border, 36 of each character.

ELECTRIC ORNAMENTS.

ORIGINAL. CAST FROM SOLID COPPER MATRIX. POINT SYSTEM.

PRICE, \$3.50.

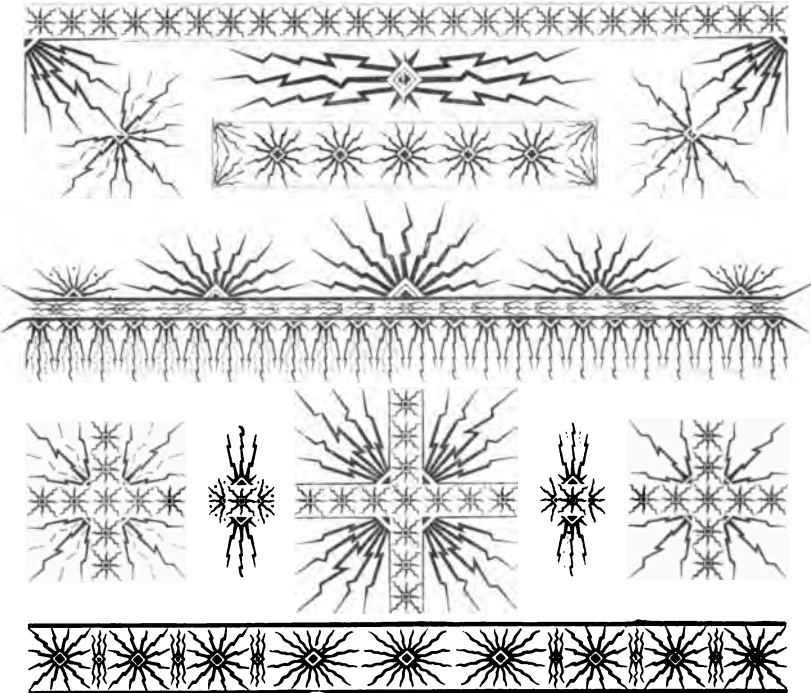
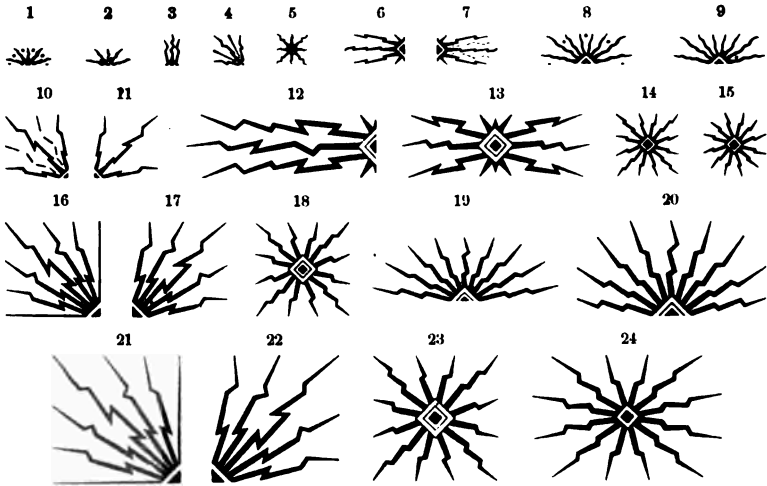

This Font contains 140 pieces: Nos. 1 and 2, twelve each; eight of No. 3; Nos. 4, 6, 7, 8, 9, 10, 11, 16, 17, 18, 21, 22, 23, four each; thirty-six (6 inches) of No. 5; Nos. 12, 13, 19, 20, 24, two each; Nos. 14, 15, five each.

RULE ORNAMENTS.

ORIGINAL. CAST FROM SOLID COPPER MATRIX. POINT SYSTEM.

PRICE. \$2.25.

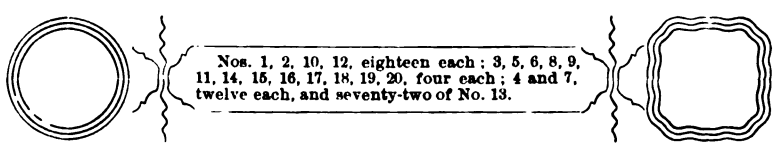
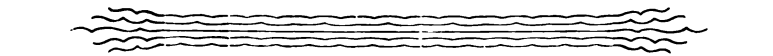
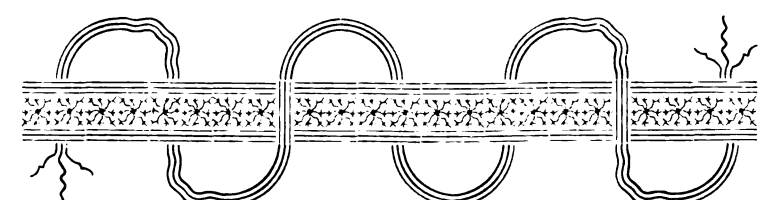
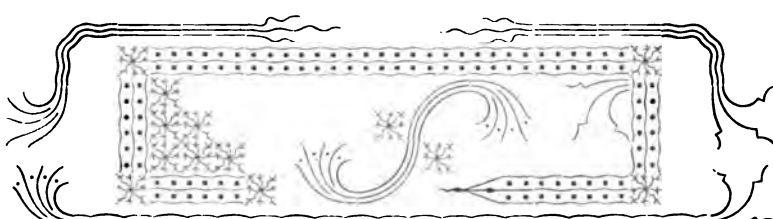
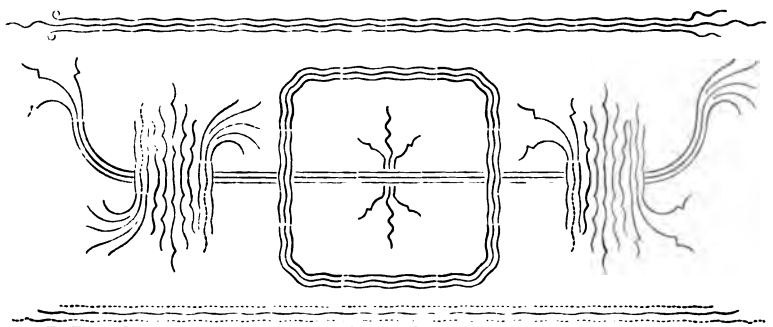
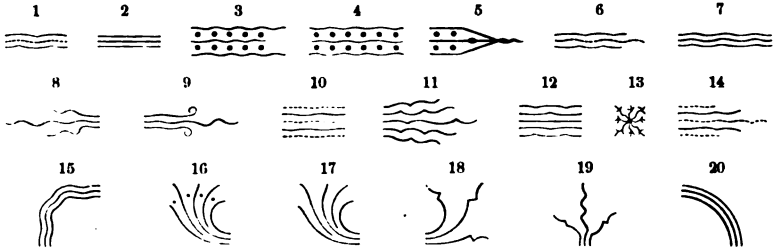

Nos. 1, 2, 10, 12, eighteen each; 3, 5, 6, 8, 9, 11, 14, 15, 16, 17, 18, 19, 20, four each; 4 and 7, twelve each, and seventy-two of No. 13.

BORDERS, ORNAMENTS, ETC.

COMBINATION BORDER

SERIES 97

CHARACTERS

1	2	8	8	14	5	7	3	4
13	9	10	15	18	16	17	11	12
19	20	21	23	22	24	25		

PRICE \$6.00



WORD ORNAMENTS, SERIES 2

1	2	3	4	5	6	7		
8	9	10	11	12	13			
14	15	16	17	18	19	20	21	22
23	24	25	26	27				
28	29	30	31	32	33			

Small Font, \$3.00. Large Font, \$5.00.

Hawks & Shattuck, San Francisco.

WORD ORNAMENTS.

ORIGINAL. CAST FROM SOLID COPPER MATRIX.

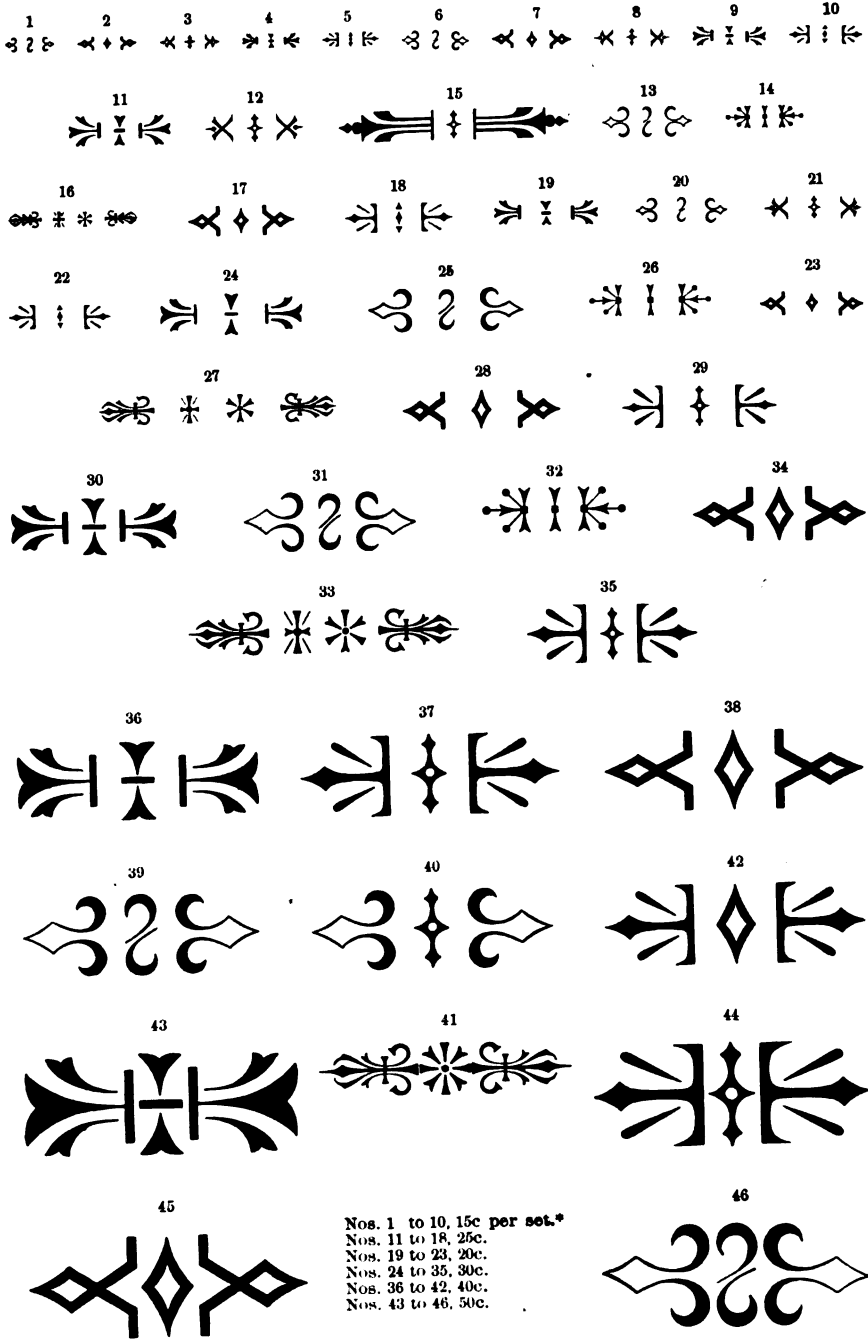

Nos. 1 to 10, 15c per set.*
 Nos. 11 to 18, 25c.
 Nos. 19 to 23, 20c.
 Nos. 24 to 35, 30c.
 Nos. 36 to 42, 40c.
 Nos. 43 to 46, 50c.

* Four of each character under a given number constitute a set

Hawks & Shattuck, San Francisco.

ELITE ORNAMENTS.

SERIES 4.

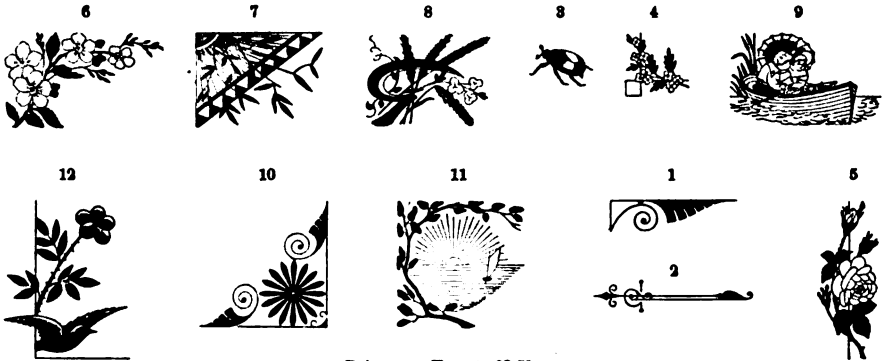

Price per Fount, \$3.50.



SERIES 5.

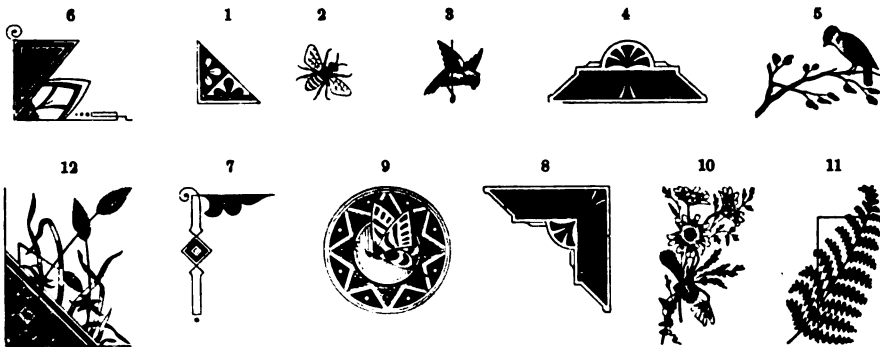

Price per Fount, \$3.00.

Hawks & Shattuck, San Francisco.

WORD ORNAMENTS.

All Characters Cast on Point System.

SERIES F—Per Font, \$1.00.

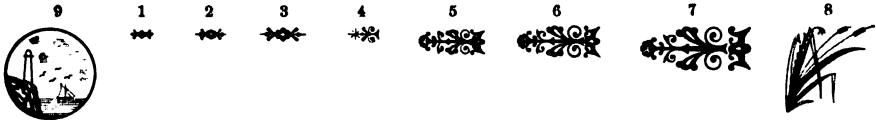

SERIES D—12-POINT, 30 cts.

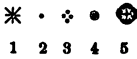

SERIES D—18-POINT, 40 cts.



SERIES D—24-POINT, 50 cts.



SERIES D—48-POINT, 75 cts.

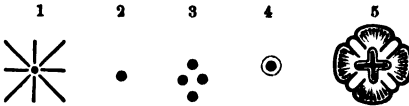

SERIES D—36-POINT, 60 cts.

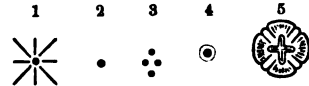

SERIES C—12-POINT, 30 cts.

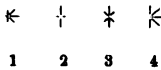

SERIES C—18-POINT, 30 cts.

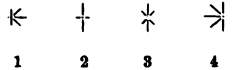

SERIES C—24-POINT, 40 cts.

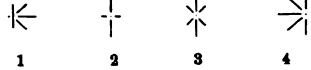

SERIES C—36-POINT, 50 cts.



LOGOTYPES.

12-POINT.



24-POINT.



18-POINT.

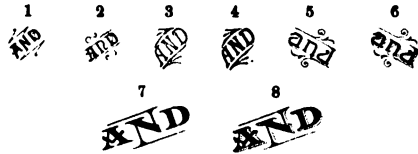

PRICES: 5 cts. each; or 50 cts. per dozen of assorted sizes.

T—LOGOTYPES, SERIES 1, TWO CHARACTERS EACH, PER FONT, \$2.20.

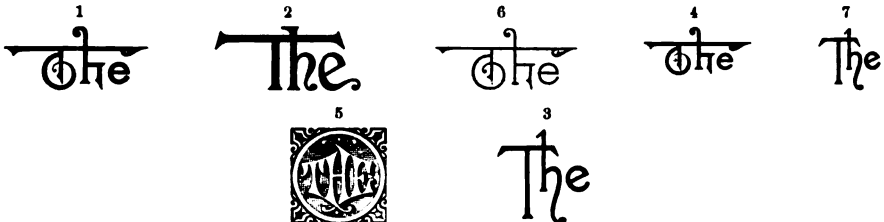

Hawks & Shattuck, San Francisco.

WORD ORNAMENTS.

F—No. 2, 12-POINT, PER FOUNT, \$1.25.

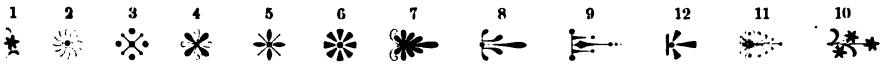

F—No. 2, 18-POINT, PER FOUNT, \$1.50.



F—No. 2, 24-POINT, PER FOUNT, \$2.00.

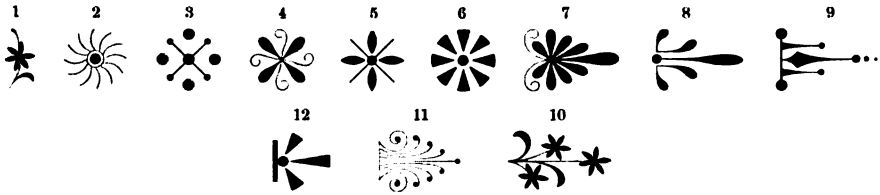

T—SERIES 1, FIVE SIZES COMPLETE, \$2.00.

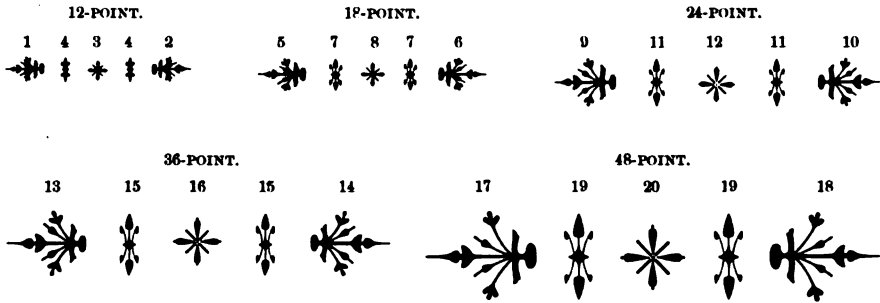

B—SERIES 1, \$1.00.



B—SERIES 2, \$1.00.

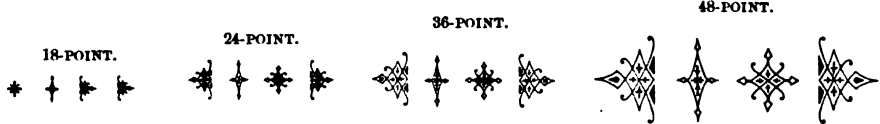

B—SERIES 3, \$1.00.

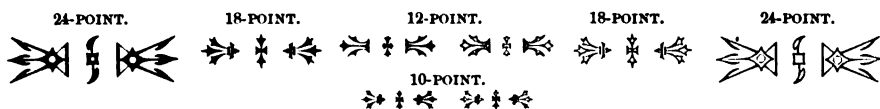

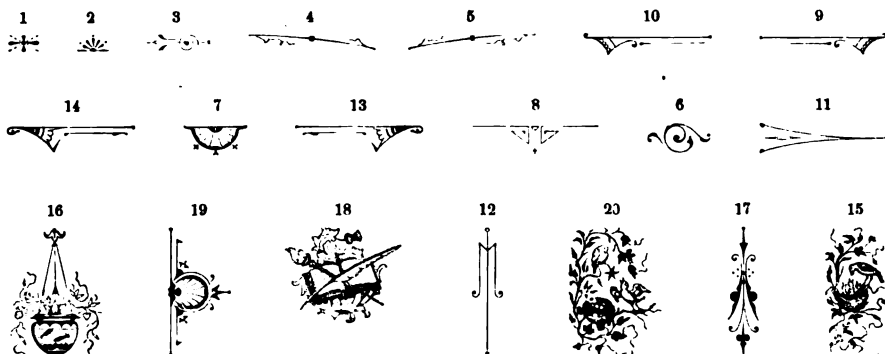
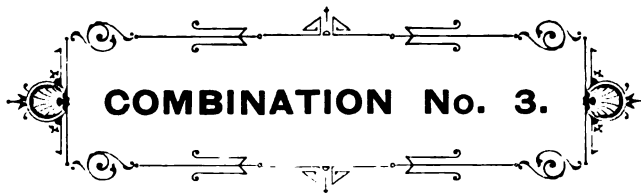

PRICE, \$4.00 PER FONT, INCLUDING SPACES AND QUADS.

HANDY BORDER.

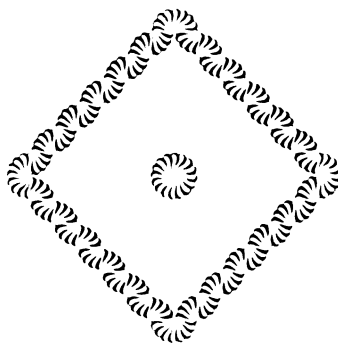
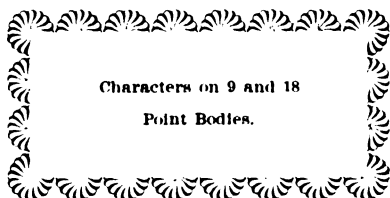

Hawks & Shattuck, San Francisco.

Digitized by Google

BORDERS.

3-POINT BORDERS.

Founts of 10 feet. Price \$2.25 per fount.

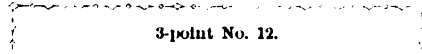

3-point No. 12.

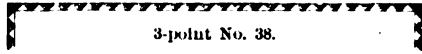

3-point No. 38.



3-point No. 22.

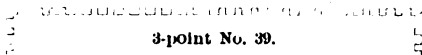

3-point No. 39.



3-point No. 29.

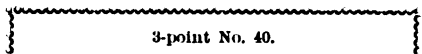

3-point No. 40.

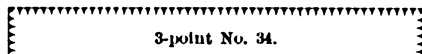

3-point No. 34.

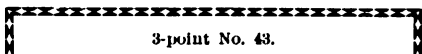

3-point No. 43.

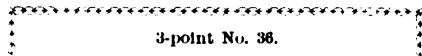

3-point No. 36.

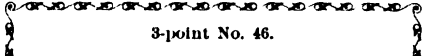

3-point No. 46.

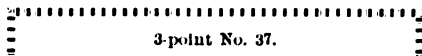

3-point No. 37.

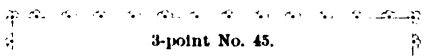

3-point No. 45.

6-POINT BORDERS.

Founts of 10 feet. Price \$2.60 per fount.

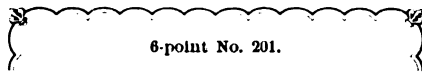

6-point No. 201.

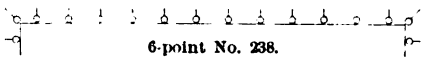

6-point No. 238.



6-point No. 215.

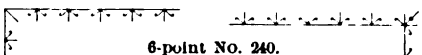

6-point No. 240.



6-point No. 205.



6-point No. 242.



6-point No. 207.

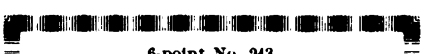

6-point No. 243.



6-point No. 226.

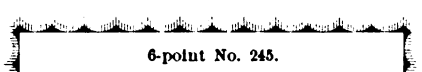

6-point No. 245.

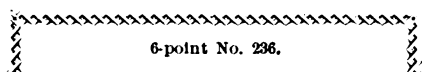

6-point No. 236.

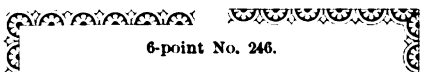

6-point No. 246.

BORDERS.

9-POINT BORDERS.

Founts of 10 feet. Price \$3.00 per fount.



9-point No. 5.



9-point No. 10.



9-point No. 6.

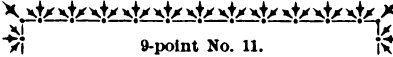

9-point No. 11.



9-point No. 8.

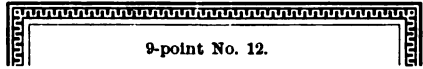

9-point No. 12.



9-point No. 13.

12-POINT BORDERS.

Founts of 10 feet. Price \$3.00 per fount.



12-point No. 212.

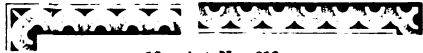

12-point No. 218.



12-point No. 216.



12-point No. 219.



12-point No. 220.

18-POINT BORDERS.

Founts of 10 feet. Price \$4.95 per fount.



18-point No. 1.



18-point No. 2.

METAL TINT BORDERS.

Founts of 10 feet. Prices—6-point \$2.60; 12-point \$3.00; 18-point \$4.95; 24-point \$5.00.



6-point Tint Border No. 1.



12-point Tint Border No. 1.



24-point Tint Border No. 1.



18-point Tint Border No. 1.

UNIQUE BORDERS.

6-POINT BORDERS.

Fonts of 10 Feet. Price, \$2.60 per font.



6-point No. 84.

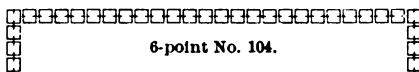

6-point No. 104.



6-point No. 85.



6-point No. 106.

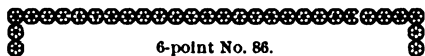

6-point No. 86.



6-point No. 107.



6-point No. 87.

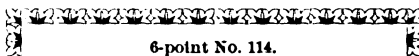

6-point No. 114.



6-point No. 101.

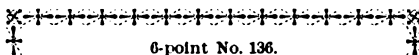

6-point No. 136.

12-POINT BORDERS.

Fonts of 5 Feet. Price, \$1.60 per font.

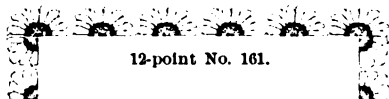

12-point No. 161.

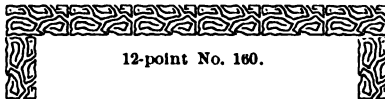

12-point No. 160.



12-point No. 70.



12-point Daisy Border.

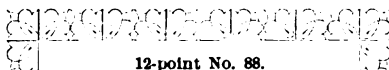

12-point No. 88.

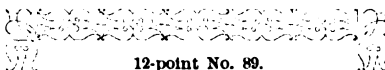

12-point No. 89.

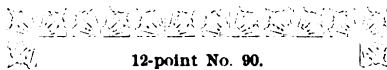

12-point No. 90.

24-POINT BORDERS.

Fonts of 3 Feet. Price, \$1.65 per Font.

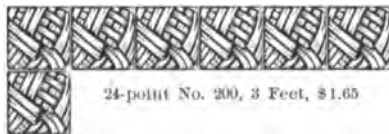

24-point No. 200, 3 Feet, \$1.65



24-point No. 201, 3 Feet, \$1.65



24-point No. 202, 3 Feet, \$1.65

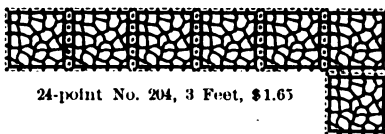

24-point No. 204, 3 Feet, \$1.65

18-point No. 150. 5 feet, Price, \$2.00.



COMMERCIAL LOGOTYPES.

18 .10 8 .10 14 .10 15 .15 16 .15 17 .25

M M M M M M M

12 .10 13 .10 Z 1563 .35 Z 1561 .35

M M Bought of Office of

B138 .30 B139 .35 B136 .35 B132 .30

BOUGHT OF **BOUGHT OF** **BOUGHT OF** **Bought of**

B140 .35 B142 .35 B143 .35 B146 .35

Bought of **BOUGHT OF** **Bought of** **BOUGHT OF**

C5079 .30 B150 .40 C5088 .40

Bought of **BOUGHT OF** **Bought of**

B145 .35 B144 .35 B137 .30 B134 .30 B133 .30

BOUGHT OF **OFFICE OF** *Office* **Office of** **Office of**

Z4234 .40 Z4565 .40

OFFICE OF **OFFICE OF**

Z4600 .40 B147 .30 Z1933 .35

OFFICE OF *Office of* **OFFICE OF**

Date Lines, from any pattern, 75 cts.

San Francisco, 189

Engraved Date No. 1, 75 cts.

San Francisco, Cal. 189 *San Francisco, Cal. 189*

Engraved Date No. 2, 75 cts.

Hawks & Shattuck, San Francisco.

CHECK BLANKS.

Z4871 .35



Z4872 .35



Z4873 .35



Z4874 .35



Z3596 .35



Z3596 .35

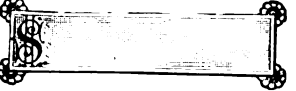

Z4877 .35



Z4878 .35

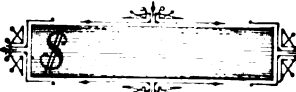

Z4566 .35

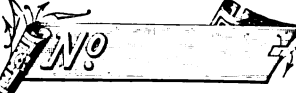

Z4567 .35



Z4569 .35



Z4570 .35

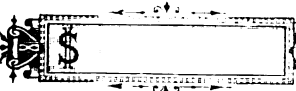

Z3584 .40



Z3585 .40



Z3586 .40



Z3577 .40



Z3578 .40

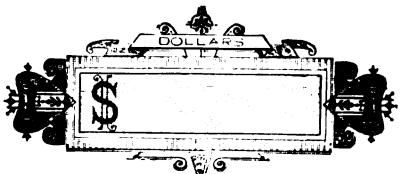

Z3579 .40



Z3564 .35



Z3565 .35



CHECK BLANKS, ETC.

C4599 .35

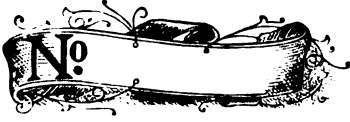

C5500 .35

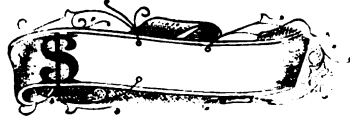

C5508 .35

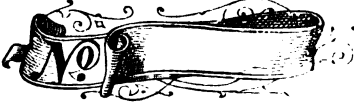

C5510 .35



Z3543 .35



Z3544 .35

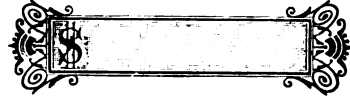

C3293 .30



C3292 .30



Z4579 .30



Z4580 .30



C3260 .25



C3256 .25



C3251 .25



C3250 .25



Z3568 .25



Z3569 .25



Z1564 .35



Z4538 .75



4911 .75



4904 .50



Check Rule per foot .69



SOMETHING

BEAUTIFUL AND ECONOMICAL

FOR PRINTERS.

WAVE ORNAMENTS.

CHARACTERS.

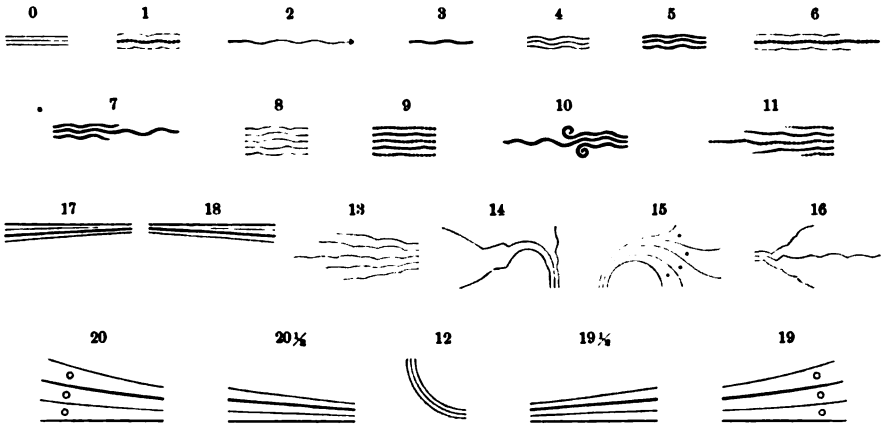

Price per Font, \$3.75.

BOOK ORNAMENTS.



Hawks & Shattuck, San Francisco.

ORIGINAL. GRACEFUL.

TYPOGRAPHIC CHARMS.

EFFECTIVE. USEFUL.

PATENT PENDING

CHARACTERS.

PRICE PER FONT \$6.50

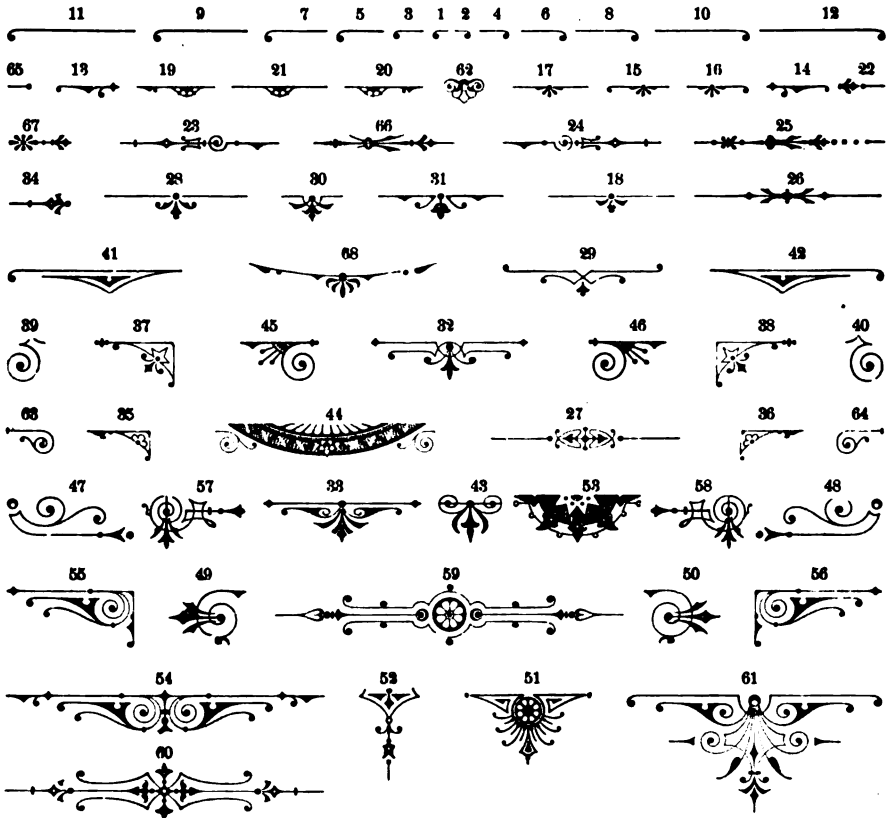

All Characters are even Nonpareils both Bodyways and in Length.

Type Cases,
STANDS, CABINETS
Furniture,
Page's Wood Type,
Fidelity
Roller Composition



Complete
Job and Newspaper
Outfits.
PRINTING INKS.
All Kinds of
Job and Cylinder
Presses.

WORD ORNAMENTS, SERIES E.



Price \$2.50 per Fount.

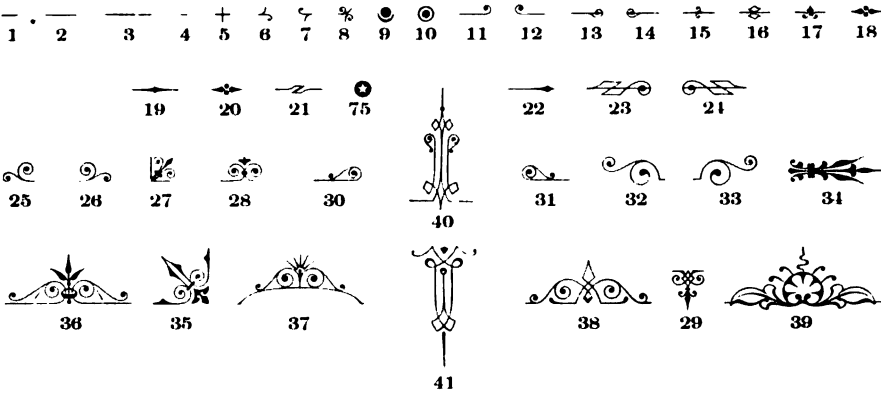

CAPITAL ORNAMENTS.

Price \$3.75 per Fount.

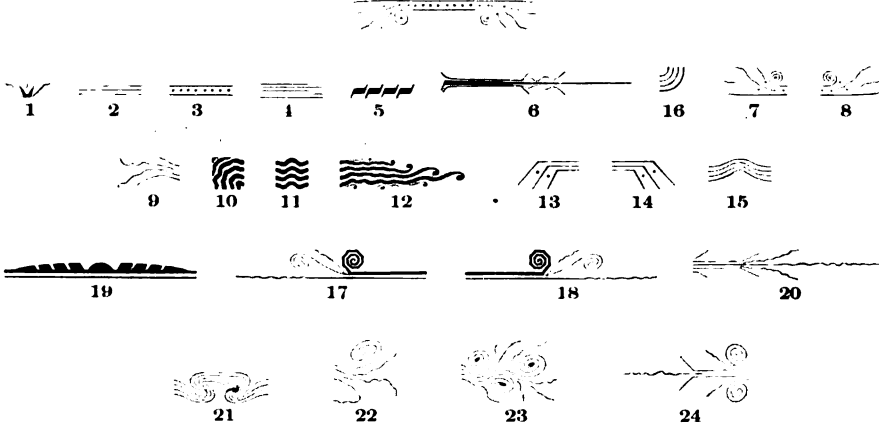

STEEL PLATE SCRIPT.

10 A 32 a

12-POINT STEEL PLATE SCRIPT

\$5.00

*I kissed her same I did by gum She Colored like a beet
 Upon my living soul she looked almost too
 good to eat I gave another kiss and then says she I do confess
 I rather kinder sorter like the Freedom of the Press*

\$135,722.00

Hawks & Shattuck, San Francisco.

CLIPPER ORNAMENTS. No. 1.

PER FONT, \$3.50.

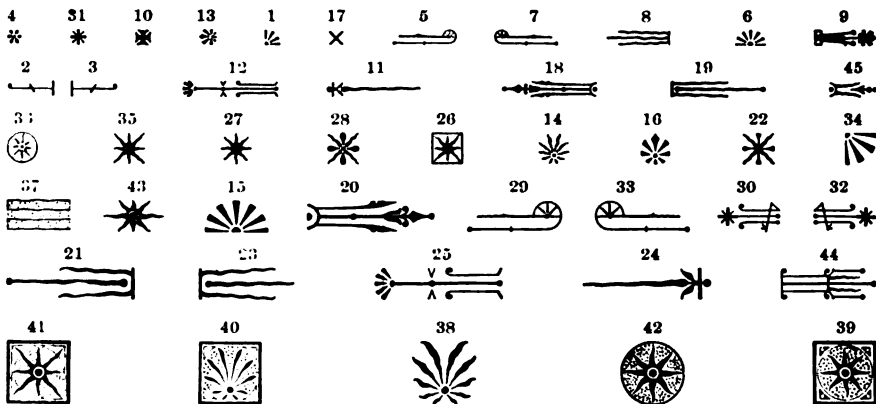

* James * Conner's * Sons *

* * *X X X X X X X X * * *

UNITED STATES TYPE FOUNDRY

No. 32 Center St. NEW YORK.

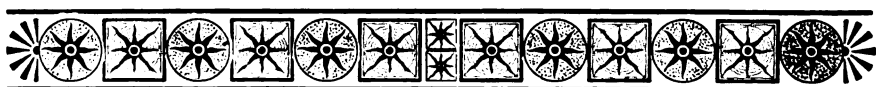
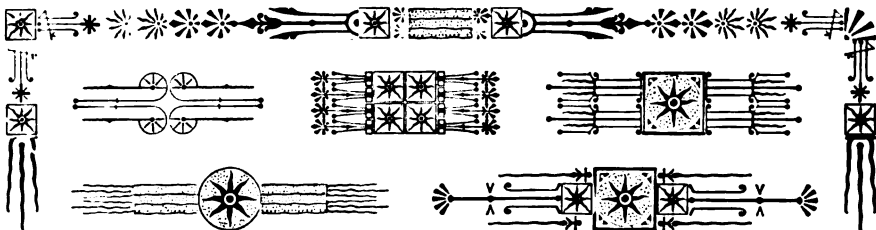

Cast on 6, 12 and 24 Point Bodies. Sorts of any character furnished to parties ordering fonts.
Order characters by numbers.

Hawks & Shattuck, San Francisco.

CLIPPER ORNAMENTS. No. 2.

PER FONT, \$4.55.

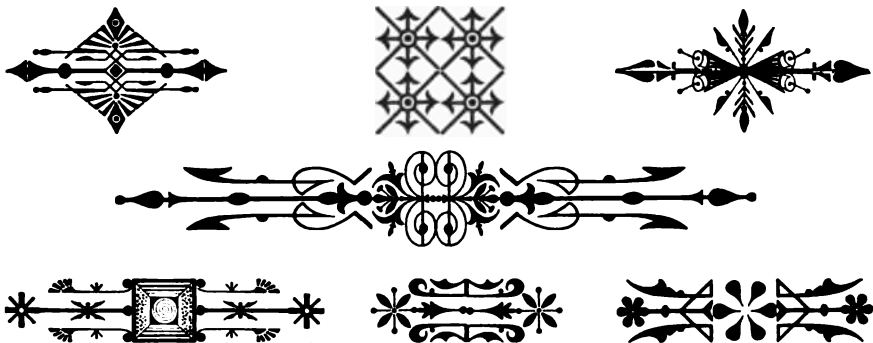
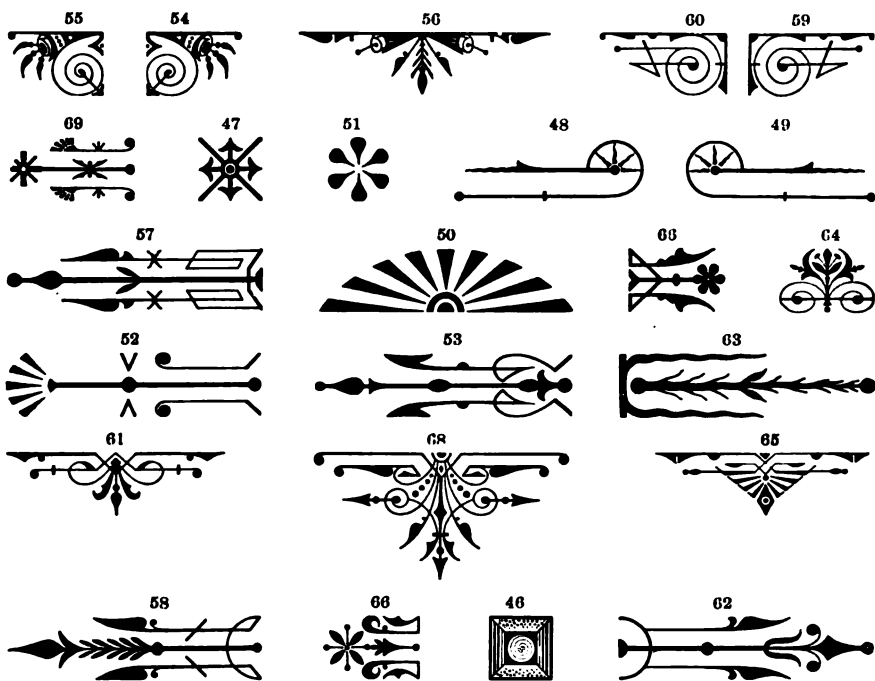

Cast on 24 and 48-Point Bodies. Fonts of any character furnished to parties ordering fonts.
 Order characters by numbers.



Hawks & Shattuck, San Francisco.

UNIQUE ORNAMENTS.



5495 75c.



5496 75c.



5407 50c



5480 50c



5481 50c



5482 50c



5497 75c.



5498 75c.



5483 50c



5484 50c



5485 50c



5486 50c



5487 60c



5488 60c



5491 60c



5492 60c



5485 60c.



5490 60c



5493 60c



5494 60c



ALL CAST ON SOLID METAL BODY.

COMBINATION CHECK TINT.

Fonts, 5 lbs. \$2.00 per pound.

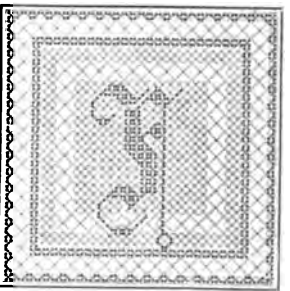
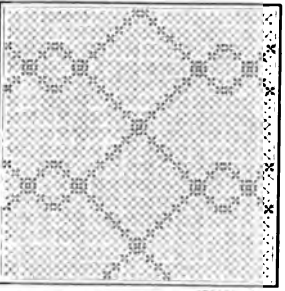
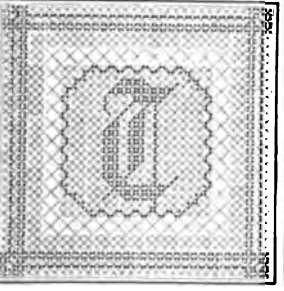
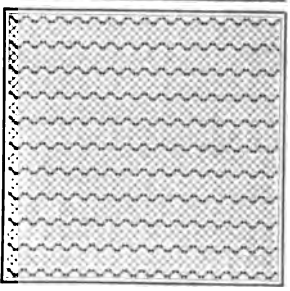
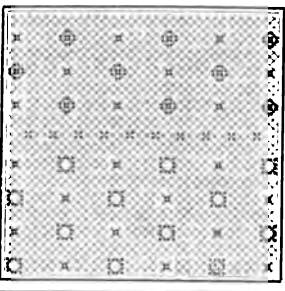
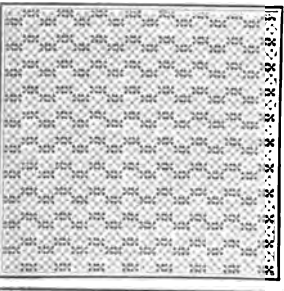
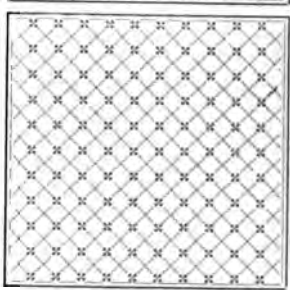
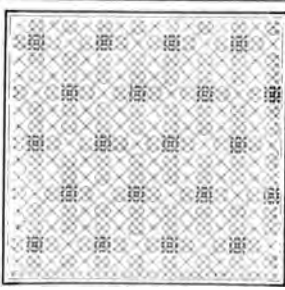
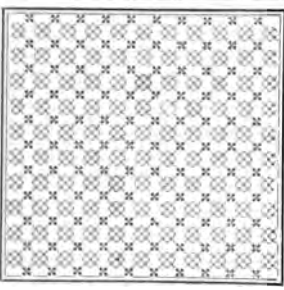
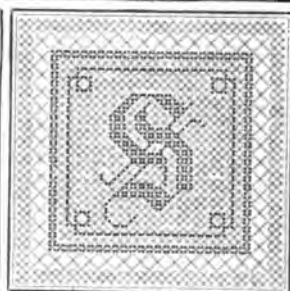
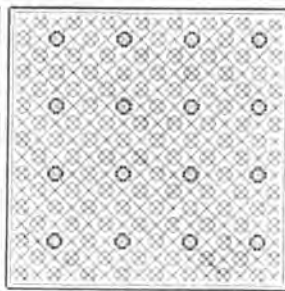
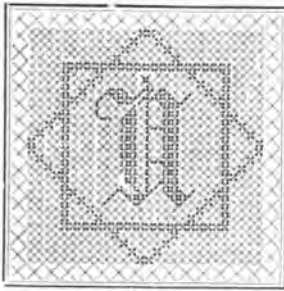
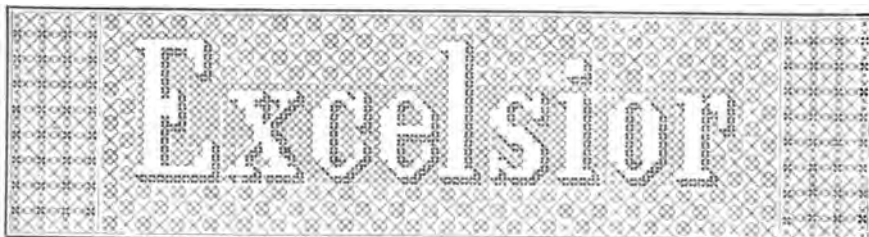

CHARACTERS

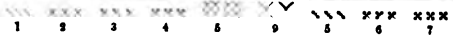

Hawks & Shattuck, San Francisco.

QUOTATIONS.

4 x 2, 4 x 3, 4 x 4, 4 x 5, 4 x 6, 5 x 2, 5 x 3 and 5 x 4.....22 cents per pound

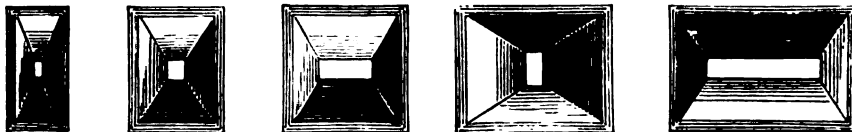

METAL LEADS.

6 to Pica and larger 16 cents per pound. 7 to Pica 24 cents per pound. 8 to Pica 28 cents per pound.
 10 to Pica 56 cents per pound and, 12 to Pica \$1.00 per pound.
 Labor Saving Leads in 12½ and 25 pound fonts and upward.....25 cents per pound.

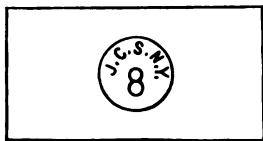

METAL SLUGS.

6, 7, 8, 9, 10, 11, 12 Point and Larger.....16 cents per pound.
 Labor Saving Slugs in 12½ and 25 pound fonts and upward.....25 cents per pound.

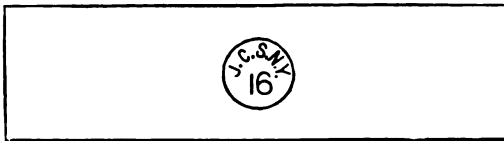

NUMBERED SLUGS.

Numbered and Lettered Slugs.....20 cents each.

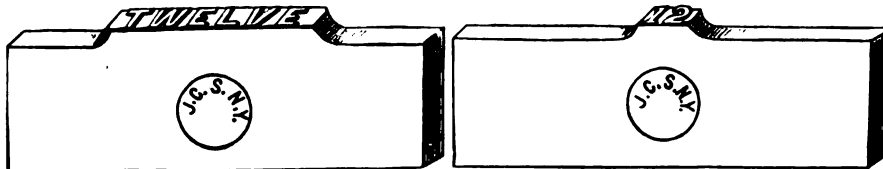

ELECTROTYPE BEARERS.....20 CENTS PER POUND.

Hawks & Shattuck, San Francisco.

CIRCULAR QUADS AND CORNERS.

(ORIGINAL.)

These quads are of lasting benefit to the general printer, and a great saving of both time and labor. A font includes four pieces of each character.

POINT BODY. PRICE PER FONT, \$3.50.

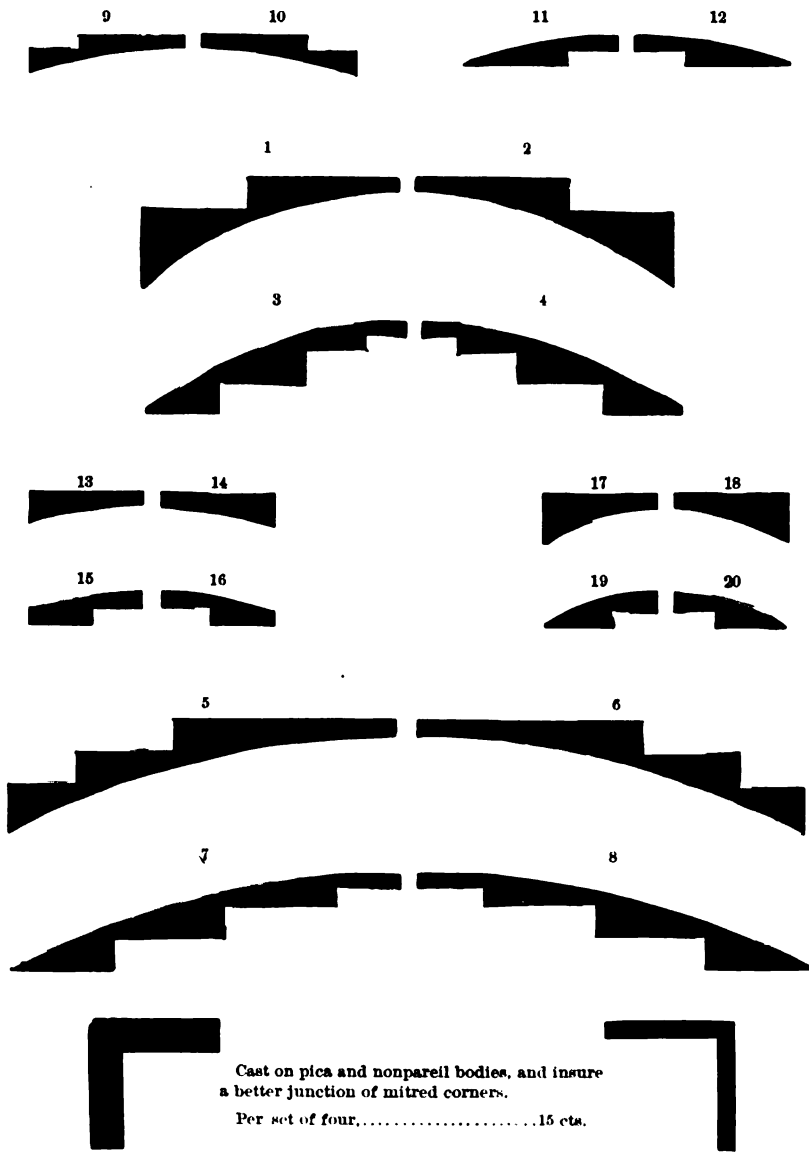

Cast on pica and nonpareil bodies, and insure a better junction of mitred corners.

Per set of four,.....15 cts.

NIFTY ORNAMENTS.

POINT SYSTEM.

CAST FROM SOLID COPPER MATRIX. (ORIGINAL.)

PRICE, \$3.00

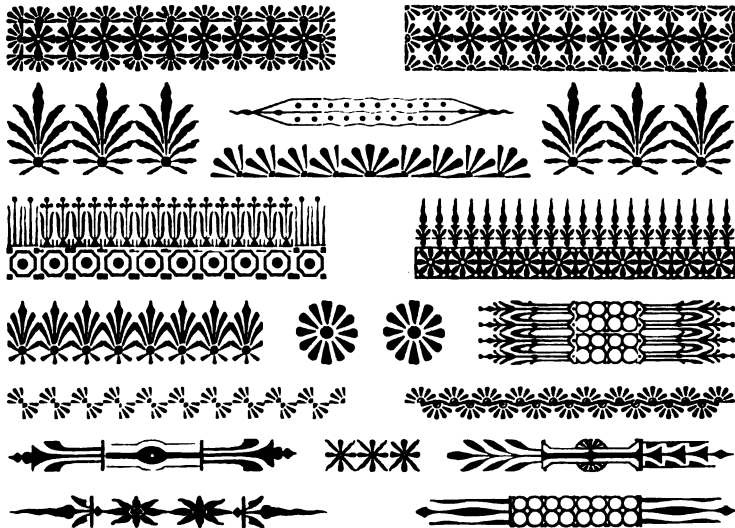
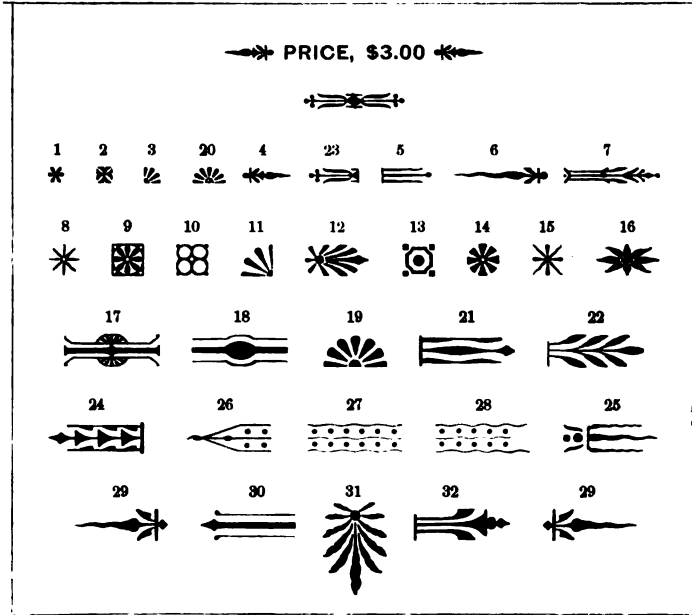

Nos. 1, 9, 10, 19, 27, twelve each; 2, 3, 11, twenty each; 4, 5, 6, 7, 23, ten each;
 8, 14, 15, 20, sixteen each; 12, 13, eight each; 16, five; 17, 18, 26, 28,
 four each; 21, 22, 24, 25, 29, 30, 32, six each; 31, five.

CARD ORNAMENTS.

Original. Cast from Solid Copper Matrix. Six-to-Pica Brass Rule, point body.
justifies with these Ornaments.

PRICE, \$2.00.

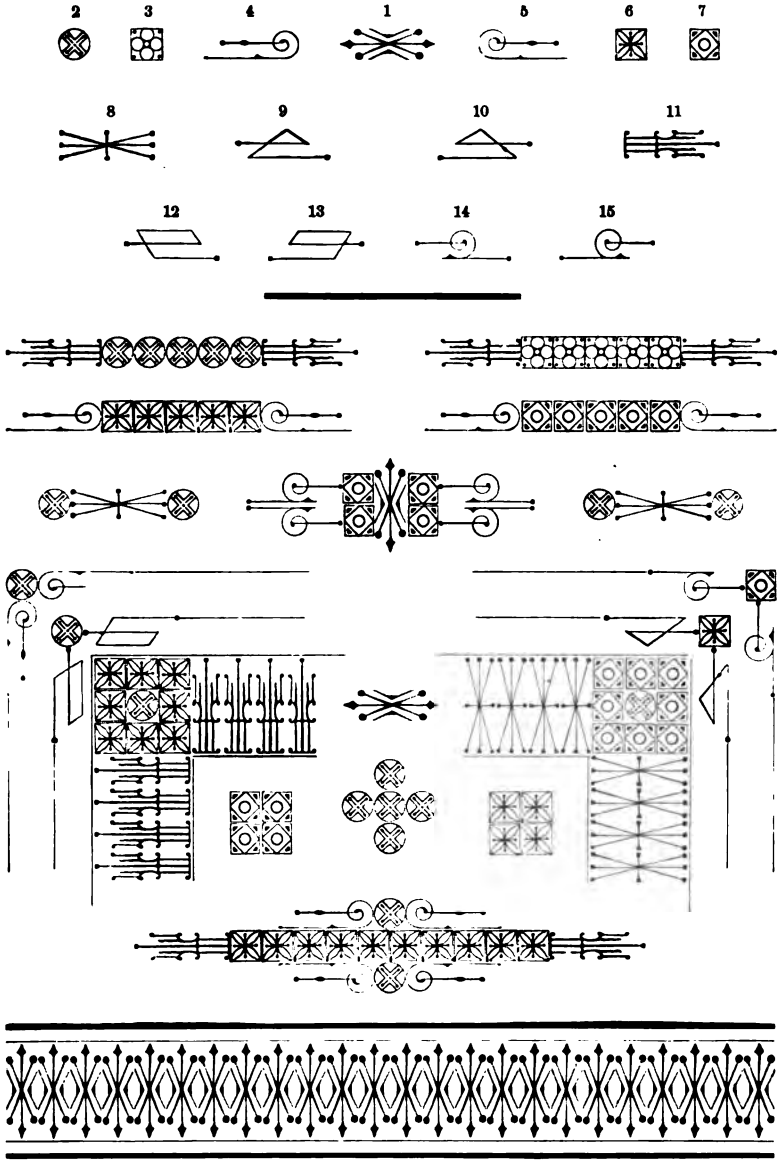

The following number of each character comprise a Font : Nos. 1 and 8, six each ;
2, 3, 6 and 7, nine each ; 4, 5, 9, 10, 11, 12, 13, 14, 15, eight each.

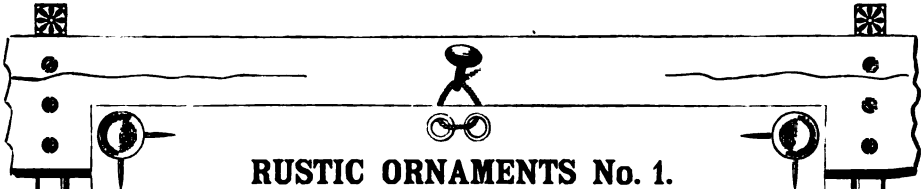

RUSTIC ORNAMENTS No. 1.

— PRICE, \$1.00. —

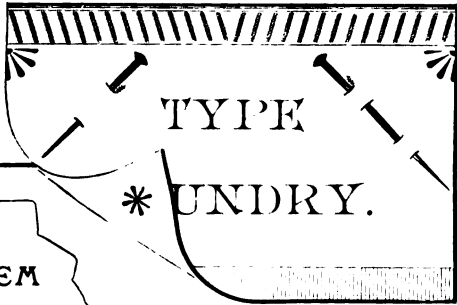
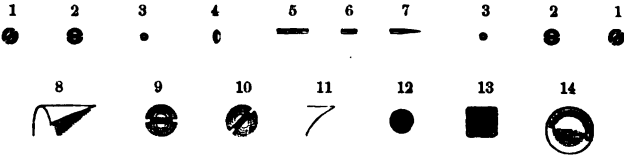

POINT ::
:: SYSTEM



RUSTIC ORNAMENTS No. 2.

PRICE, \$1.50.

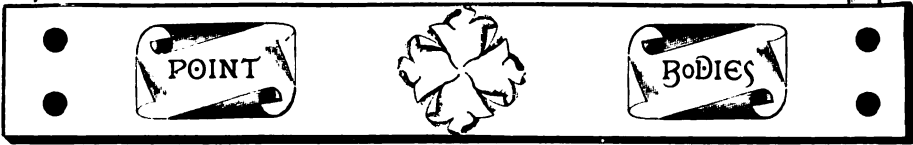
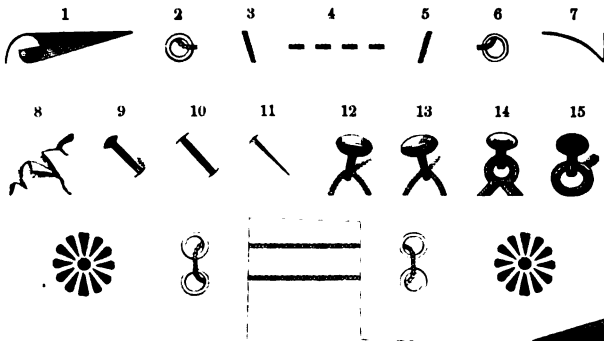

RECIPE MARKS AND BLACK FISTS.

CAST ON EVEN POINT BODIES.

CAST FROM SOLID COPPER MATRIX. (PATENTED.)

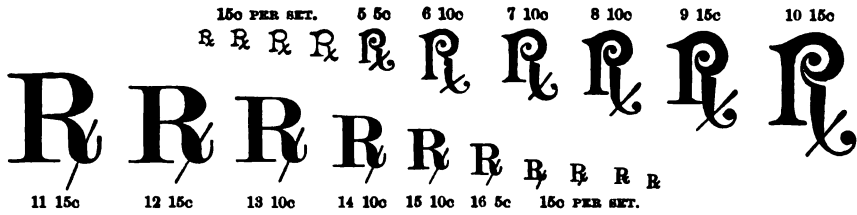

Complete font of Plain, Fancy or Text Recipe Marks, 75c.

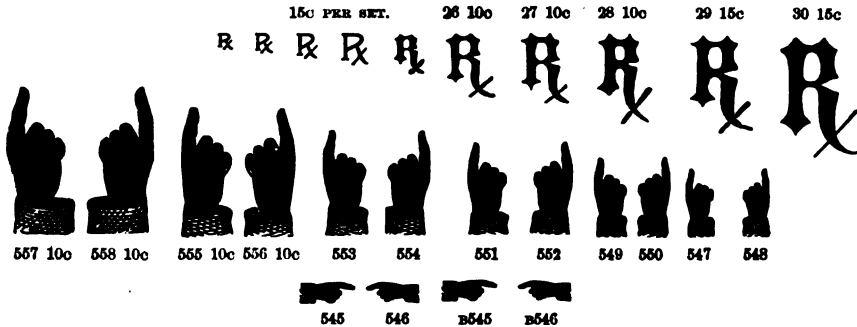

Font of Fists, 85c. Nos. 545 to 554 5c each.

MALTESE CROSSES AND STARS.

Nos. 1 to 4 in sets of 4 each 15c per set.

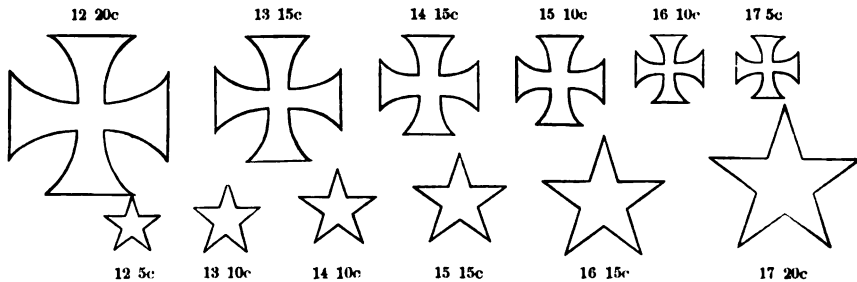
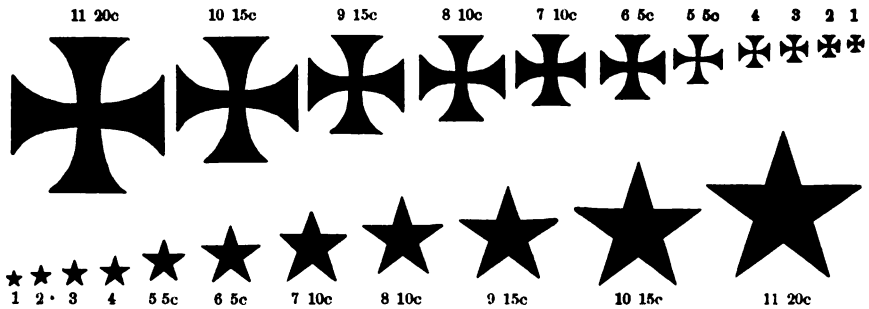

MEDICAL SIGNS, ARROWS, BLANKS.

CAST FROM SOLID COPPER MATRIX.

PUT UP IN SMALL FONTS, WITH PRICE PER POINT.

6 POINT MEDICAL SIGNS. 25c

333 333 999 RRR VVV MM HHHH

7 POINT MEDICAL SIGNS. 25c

3333 333 9999 RRRR VVVV

5 1/2 POINT, AGATE, MEDICAL SIGNS. 25c

33333333 333333333333 9999999999 RRRRRRRRRR

8 POINT MEDICAL SIGNS. 25c

333 333 999 RR VV MM HHHH

9 POINT MEDICAL SIGNS. 25c

3333 3333 9999 RRRR VVVV

10 POINT MEDICAL SIGNS No. 1. 40c

3 3 3 3 9 9 R R V V MM HHHH

10 POINT MEDICAL SIGNS No. 2. 40c

3 3 3 3 9 9 R R V V MM HH

12 POINT MEDICAL SIGNS. 40c

3 3 3 3 9 9 R R MM HH

11 POINT MEDICAL SIGNS. 40c

3333 3333 9999 RRRR V V V

6 POINT ARROWS, 15c PER SET.

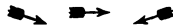

BLANKS, For Engraving Marks, Brands, Etc.

1 5c



3 10c



5 20c



4 15c



2 5c



All the Type on this page are cast on the Point System. Quantities of any character at pound rates.

CHESSMEN, CHECKERS AND DOMINOES.

ORIGINAL. CAST FROM SOLID COPPER MATRIX.

11 POINT CHECKERS. PER FONT, \$1.44.

5 1 5 2 5 3 5 4 5



16 POINT CHESSMEN. PER FONT, \$4.80.

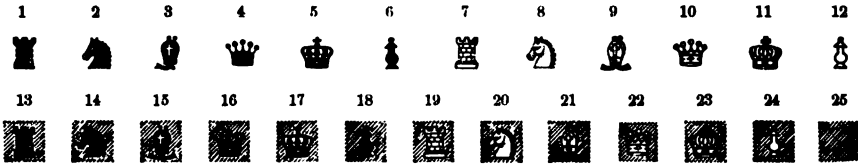

16 POINT CHECKERS. PER FONT, \$3.40.

25 26 27 28 29 25



20 POINT CHESSMEN. PER FONT, \$4.80.

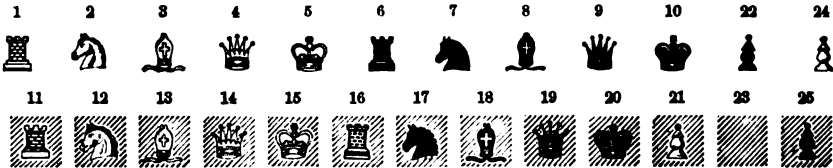

20 POINT CHECKERS. PER FONT, \$3.40.

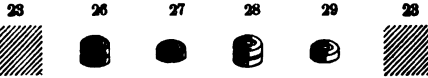

24 POINT CHESSMEN. PER FONT, \$4.80.

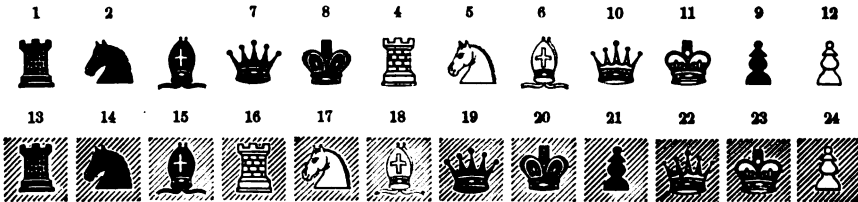

24 POINT CHECKERS. PER FONT, \$3.40.

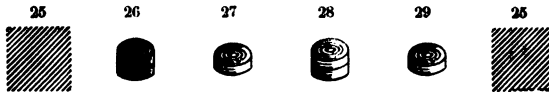

Border for Checkers and Chessmen, 50c. extra.

48 POINT DOMINOES. 15 CTS. EACH. PER FONT, \$3.75.

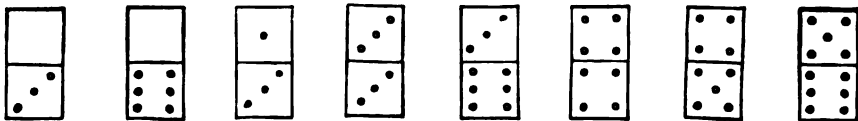

CUPID INITIALS.

ELECTROTYPES, ON METAL BODY. PRICE, 50 CENTS EACH.

COMPLETE ALPHABET, \$10.00.



BROWNIES.

6455 .25



6456 .25



6457 .25



6458 .25



6459 .25



6460 .25



6461 .20



6462 .20



6463 .20



6464 .50



6465 .25



6466 .25



6467 .25



6468 .25



6469 .25



6470 .25



6473 .50



6471 .25



6472 .25



6474 .50



6475 .25



6476 .25



6477 .25



6478 .75



BROWNIES.

6479 .50



6480 .50



6481 .50



6482 .50



6488 .50



6484 .60



6485 .50



6486 .30



6487 .40



6488 .40



6489 .75



6490 .25



6495 .35



491 .40



6492 .40



6498 .40



6494 .30



6434 .50



6435 .50



6436 .50



BROWNIES.

6501 .50



6500 .50



6441 .50



6438 .50



6439 .50



6440 .50



6437 .50



6442 .75



6444 .75



6450 .75



6449 .50



6452 .50



6419 \$1.00



BROWNIES.

6453 .50



6448 .50



6445 .75



6451 .25



6446 .50



6447 .50



6454 .85



6426 .75



6497 .75



6420 .50



6138 .35



6443 .75



BROWNIES.

6499 .85



6912 \$1.50



6498 \$1.25

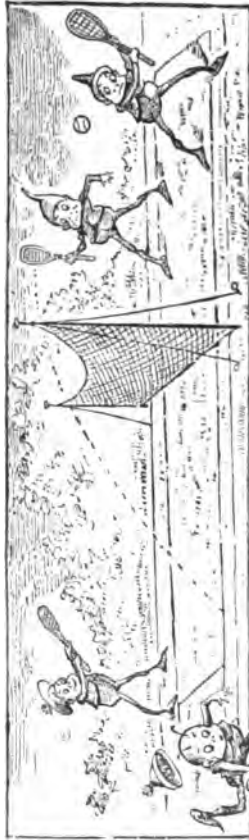

6911 \$1.25



6512 .75



6422 \$1.00



Hawks & Shattuck, San Francisco.

BROWNIES.

6619 \$2.00

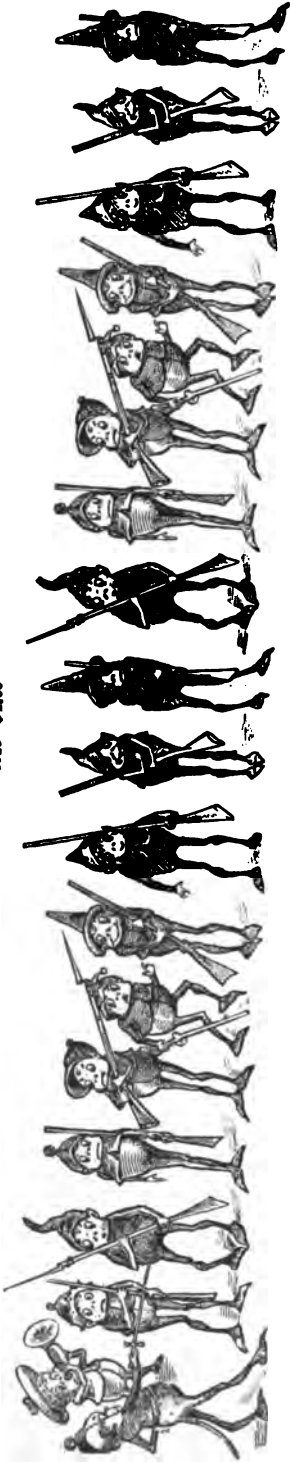

641R \$1.75



6423 \$2.00



Hawks & Shattuck, San Francisco.

ILLUSTRATED CORNERS.

11 .35



12 .35



13 .35



14 .35



15 .35



16 .35



17 .35



18 .35



19 .50



20 .50



21 .50



22 .50



23 .50



24 .50



25 .50



26 .50



27 .50



28 .50



29 .50



30 .50



ILLUSTRATED CORNERS.

31 .50



32 .50



33 .50



34 .50



35 .50



36 .50



37 .50



38 .50



39 .50



40 .50



41 .50



42 .50



43 .50



44 .50



45 .50



46 .50



POSTER TYPE.

THE following pages show the New Process Wood Type kept by us in stock. Other styles than those shown in this book will be furnished on special order, in 30 days time.

We carry type up to 40-line, though not shown in these pages.

Founts of 8-line and less are put up to a "4A, 4a and figures" plan or scheme. Larger sizes to 3A, 3a and figures. There is occasionally a deviation from this. Founts can be put up to any scale, to order.

The prices quoted here are the list figures of the manufacturers. From these prices we allow, in case of cash payment, a discount of 25 per cent. This discount applies to Wood Type only.

POSTER CALEDONIAN.

Founts 25 lbs. and over.

12-POINT POSTER CALEDONIAN.

54 cts. per lb.

"MUST BE STEADY AND SOBER,"

Are the Talismanic Words frequently found in the "want" columns of the daily newspapers. What do they Teach? Simply that Drunkards cannot be trusted and are not wanted at any price. Alas, the poor printer! \$1234567890

Founts 25 lbs. and over.

18-POINT POSTER CALEDONIAN.

52 cts. per lb.

MAN, FEEBLE AND BENT

With age is about to dispose of his share in the Liveforever Insurance Company; will swap for a Brindled Bull Ratter. Address, XX. \$1234

Founts 25 lbs. and over.

22-POINT POSTER CALEDONIAN.

50 cts. per lb.

GREATEST SACRIFICE

Hiram Cuttsclose, the Tailor furnishes Ready-made Suits to measure and guaranteed to fit the fat or lean \$12.34

Founts 25 lbs. and over.

28-POINT POSTER CALEDONIAN.

50 cts. per lb.

AUCTIONEER

**Miller, of Los Angeles,
California, settles small
ranch claims for \$123**

Founts 25 lbs. and over.

36-POINT POSTER CALEDONIAN.

50 cts. per lb.

RUSTBOUND

**Freight cars for sale
Oiled and Soiled 4**

Founts 50 lbs. and over.

40-POINT POSTER CALEDONIAN.

50 cts. per lb.

HOSEMEN

**Double Trucker
Steam 2 Engine**

Founts 50 lbs. and over.

48-POINT POSTER CALEDONIAN.

50 cts. per lb.

MINERS

**Strike it Rich
Sometimes**

No. 500.

Caps and Figs #3 96

FOUR LINE No. 500

4 A 4 a Figs #6 66

COUSIN Mission 82

Caps and Figs #4.62

FIVE LINE No. 500

4 A 4 a Figs #7 77

PUBLIC Means!

Caps and Figs #5]28

SIX LINE No. 500

4 A 4 a Figs #8 88

BER Mains 8

Caps and Figs #6 60

EIGHT LINE No. 500

4 A 4 a Figs #11 10

HER the 4

Caps and Figs #5 94

TEN LINE No. 500

3 A 3 a Figs #9 13

IN mor 6

Caps and Figs #7 92

TWELVE LINE No. 500

3 A 3 a Figs #9 96

Tare 23

Caps and Figs #8 58

FIFTEEN LINE No. 500

3 A 3 a Figs #10 79

Bran 1

No. 502.

3 A Figs

TEN LINE No. 502

#5 55

READERS 14

3 A Figs

TWELVE LINE No. 502

\$6 08

BENDER 8

No. 503.

Caps and Figs \$5 28

SIX LINE No. 503

4 A 4 a Figs \$8 88

STEAMER Mane 23

Caps and Figs \$5.28

EIGHT LINE No. 503

4 A 4 a Figs \$11 10

HEAD Advan 4

Caps and Figs \$7.26

TEN LINE No. 503

4 A 4 a Figs \$12 21

BUNNishers 4

Caps and Figs \$6 06

TWELVE LINE No. 503

3 A 3 a Figs \$9 96

AMENati 8

Caps and Figs \$6 56

FIFTEEN LINE No. 503

3 A 3 a Figs \$10 79

BANds 3

No. 504.

Caps and Figs \$6 28

FOUR LINE No. 504

4 A 4 a Figs \$8 88

FOR Rich 8

Caps and Figs \$5 94

FIVE LINE No. 504

4 A 4 a Figs \$9 99

ANTin 4

Caps and Figs §7 26

SIX LINE No. 504

4 A 4 a Figs §12 21

NAre 6

Caps and Figs §6 56

EIGHT LINE No. 504

3 A 3 a Figs §10 79

Cam 3

Caps and Figs §7 07

TEN LINE No. 504

3 A 3 a Figs §11 62

Me 3

Caps and Figs §7.57

TWELVE LINE No. 504

3 A 3 a Figs §12 45

De 1

No. 505,

4 A Figs

FOUR LINE No. 505

\$5 28

CRANSTON 4

4 A Figs

FIVE LINE No. 505

\$5 84

CHICAGO 31

4 A Figs

SIX LINE No. 505

\$7 28

BRIGHT 1

4 A Figs

EIGHT LINE No. 505

\$8 88

ROPE 4

3 A Figs

TEN LINE No. 505

\$7 07

NOR 6

HIS 8

No. 506.

Caps and Figs 83 96

FOUR LINE No. 506

4 A 4 a Figs 86 66

REVOL America 4

Caps and Figs 84 62

FIVE LINE No. 506

4 A 4 a Figs 87 77

SION Marnet 3

Caps and Figs 85 28

SIX LINE No. 506

4 A 4 a Figs 88 88

ANERoids 41

Caps and Figs 86 60

EIGHT LINE No. 506

4 A 4 a Figs 90 10

EMinor 5

Caps and Figs \$5 55

TEN LINE No. 506

3 A 3 a Figs \$9 13

THad 4

Caps and Figs \$6 06

TWELVE LINE No. 506

3 A 3 a Figs \$9 96

RIun 3

Caps and Figs \$6 52

FIFTEEN LINE No. 506

3 A 3 a Figs \$7 70

DOng 6

No. 509.

Caps and Figs \$4 20

FOUR LINE No. 509

4 A 4 a Figs \$7 21

SUBSCRIPTio 6

Caps and Figs \$5 28

FIVE LINE No. 509

4 A 4 a Figs \$8 88

PROIDour 17

Caps and Figs \$5 94

SIX LINE No. 509

4 A 4 a Figs \$9 99

ROTvea 18

Caps and Figs \$7 26

EIGHT LINE No. 509

4 A 4 a Figs \$12 21

HOate 5

Caps and Figs \$6 06

TEN LINE No. 509

3 A 3 a Figs \$9 06

Blart6

Caps and Figs #6 56

TWELVE LINE No. 509

3 A 3 a Figs #10 70

Flat 3

Caps and Figs 7 07

FIFTEEN LINE No. 509

3 A 3 a Figs #11 62

No 2

No. 511.

Caps and Figs #3 96

FOUR LINE No. 511

4 A 4 a Figs #6 66

ACHCLM Remini \$68

Caps and Figs #3 62

FIVE LINE No. 511

4 A 4 a Figs #7 77

COMMUNmodat 3

Caps and Figs #5 28

SIX LINE No. 511

4 A 4 a Figs #8 88

NIPUM Insur 9

 Caps and Figs #6 60

EIGHT LINE No. 511

4 A 4 a Figs #11 10

ROUNeha 5

Caps and Figs #7 26

TEN LINE No. 511

3 A 3 a Figs #9 18

REDhar 8

Caps and Figs #8 06

TWELVE LINE No. 511

3 A 3 a Figs #9 96

UNDon 1

00ab1

8-LINE STARS.



No. 1 10 Cts.



No. 2 15 Cts.



No. 3 35 Cts.

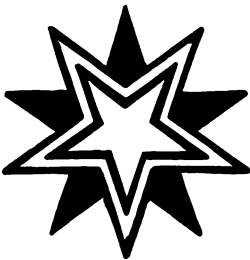

No. 6 20 Cts.

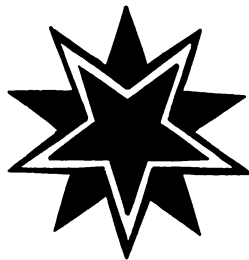

No. 7 20 Cts.

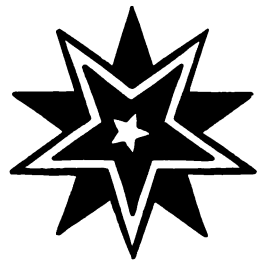

No. 8 20 Cts.

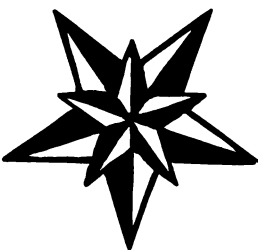

No. 4 20 Cts.

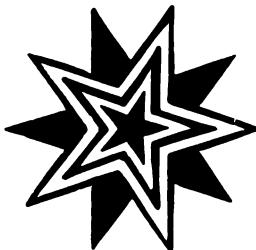

No. 10 20 Cts.

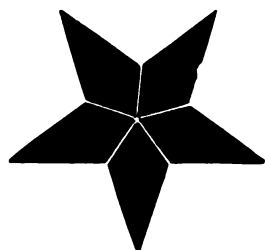

No. 12 15 Cts.

No. 24.

Caps and Figs #14 14

FIFTEEN LINE No. 24

3 A 3 a Figs #23 24

ROBED 2

Caps and Figs #27 30

THIRTY LINE No. 24

3 A 3 a Figs #48 82

GRE

Caps and Figs #18 18

TWENTY LINE No. 24

3 A 3 a Figs #29 88

URNO

Caps and Figs #22 22

TWENTY-FOUR LINE No. 24

3 A 3 a Figs #36 52

RIDE

No. 35.

Caps and Figs #13 13

FIFTEEN LINE NO. 35

3 A 3 a Figs #21 58

HDE 3

Caps and Figs #24 24

THIRTY LINE NO. 35

3 A 3 a Figs #39 84

RE

Caps and Figs §16 16

TWENTY LINE No. 35

3 A 3 a Figs §26 56

DBO

Caps and Figs §19 19

TWENTY-FOUR LINE No. 35

3 A 3 a Figs §31 54

H4

No. 37.

Caps and Figs §14 14



FIFTEEN LINE No. 37



3 A 3 a Figs §23 24



Caps and Figs §27 27



THIRTY LINE No. 37



3 A 3 a Figs §48 82

Caps and Figs #18 18

TWENTY LINE No. 37

3 A 3 a Figs #29 88

10B

Caps and Figs #22 22

TWENTY-FOUR LINE No. 37

3 A 3 a Figs #36 52

13Z

CATCH WORDS.

SIX-LINE 15 CENTS EACH.

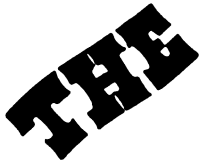

5



10



11

EIGHT-LINE 18 CENTS EACH.



10



12



24



31



10



8

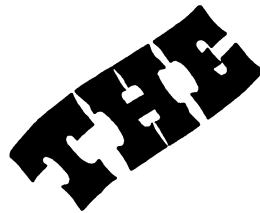

5



11



27



28



4



28

✓ Catch Words furnished on 4-line, 5-line, 6-line and 8-line. Prices for 4-, 5- and 6-line 15 cents each; 8-line, 18 cents each. Order style wanted by number, and state size wanted.

FIVE-LINE SPACE ORNAMENTS.

30 CENTS A PAIR.

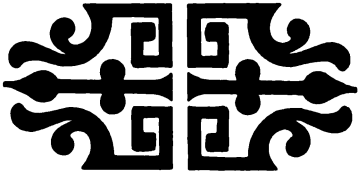

400



401



402



403



404

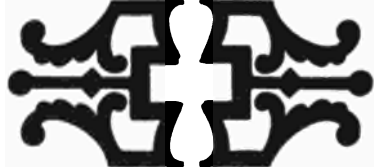

405



406



407

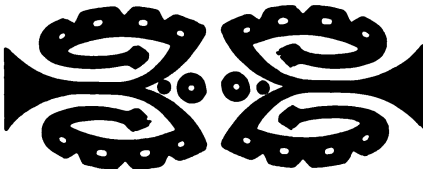

408



410



409

SIX LINE, 35 CENTS; SEVEN LINE, 40 CENTS; EIGHT LINE, 45 CENTS; TEN LINE, 50 CENTS A PAIR

WOOD BORDER.

Sold in founts of 10 feet. Price per foot below.

No. 209. 60 Cents.



No. 211. 60 Cents.



No. 185. 70 Cents.



No. 308 1/2. 70 Cents.



No. 309. 70 Cents.



No. 310. 80 Cents.



No. 311. 80 Cents.



No. 213. 70 Cents.



No. 189. 80 Cents.

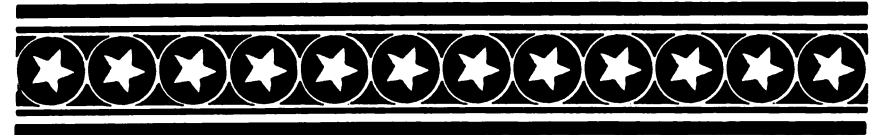

No. 220. \$1 00.

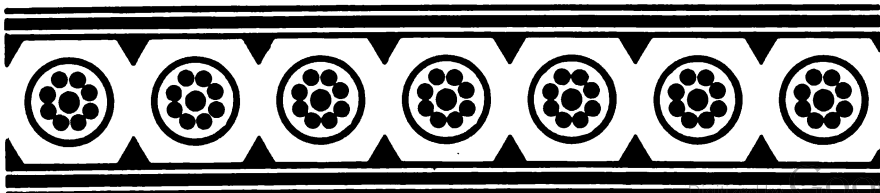

WOOD RULE.

Sold in yard strips at 15 cents per yard.

No. 1.



No. 2.



No. 3.



No. 4.



No. 6.



No. 8.



No. 10.



No. 12.



No. 14.



No. 16.



No. 18.



No. 2½.



No. 3½.



No. 5.



No. 7.



No. 9.



No. 11.



No. 13.



No. 15.



No. 17.



No. 19.



To avoid fine, this book should be returned
or before the date last stamped below

Stanford University Libraries



3 6105 012 077 223

Stanford University Library
Stanford, California

In order that others may use this book,
please return it as soon as possible, but
not later than the date due.



