

G. H. ZIEGLER.
TYPE CASTING MACHINE.

No. 523,301.

Patented July 17, 1894.

FIG. 1.

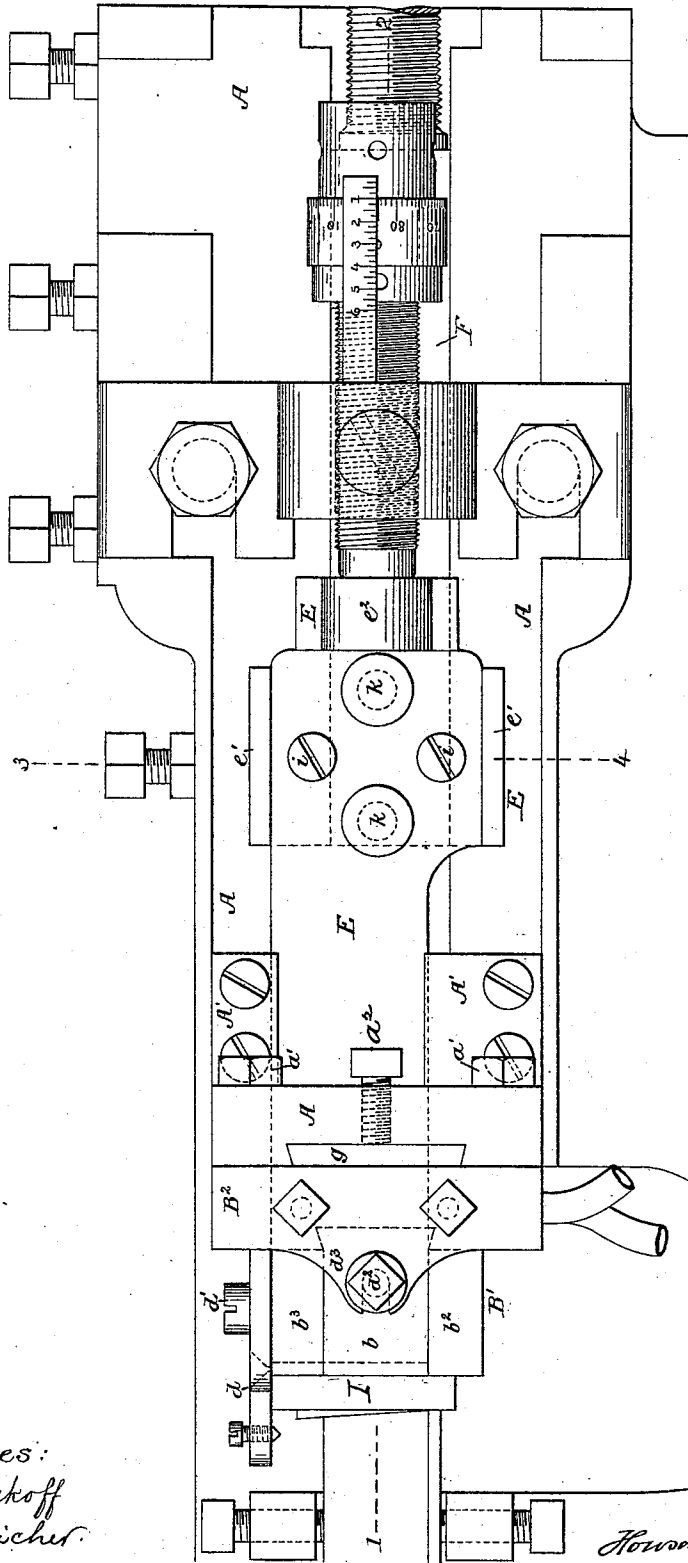

Witnesses:
Alex. Barkoff
W. Schlicher

Inventor:
George H. Ziegler
by his Attorneys
Howan & Howan

(No Model.)

3 Sheets—Sheet 2.

G. H. ZIEGLER. TYPE CASTING MACHINE.

No. 523,301.

Patented July 17, 1894.

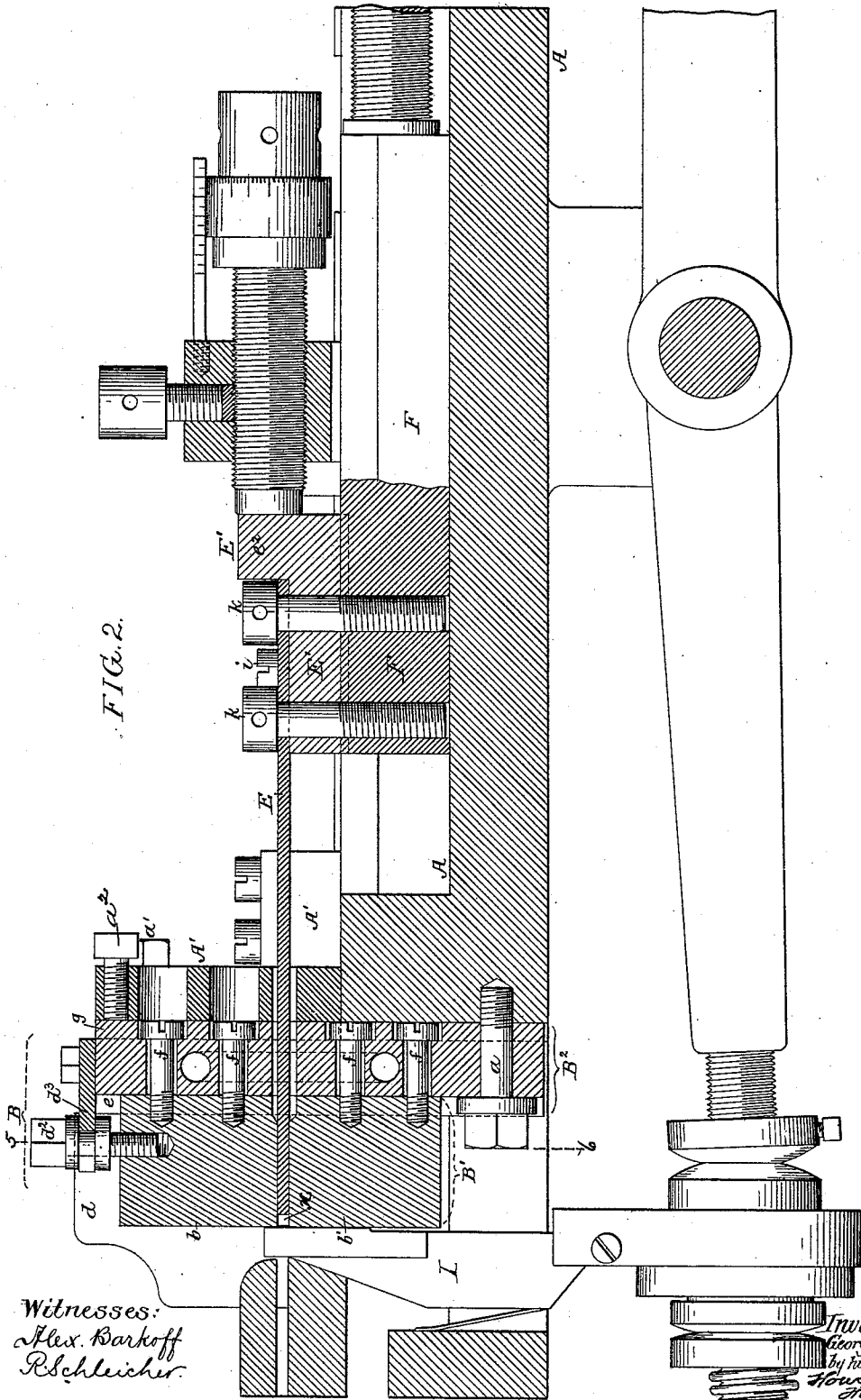

FIG. 2.

Witnesses:
Alex. Barkoff
R. Schleicher

Inventor:
George H. Ziegler
by his Attorneys
Howard
Howson

G. H. ZIEGLER.
TYPE CASTING MACHINE.

No. 523,301.

Patented July 17, 1894.

FIG. 4

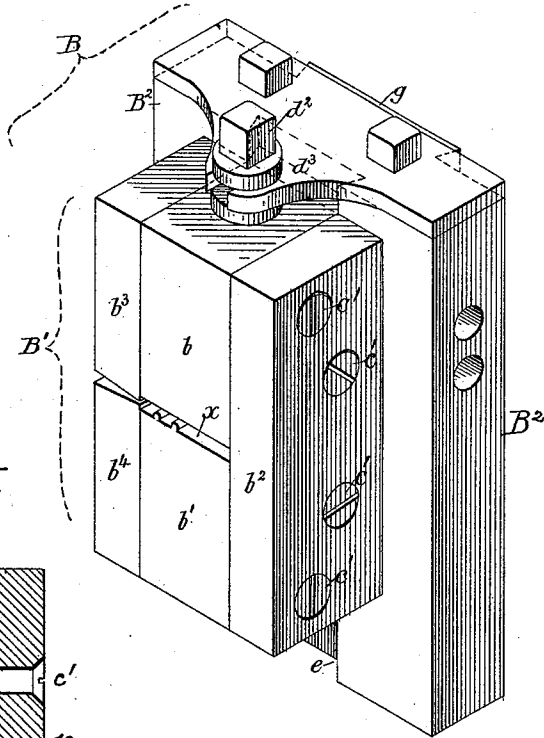

FIG. 5.

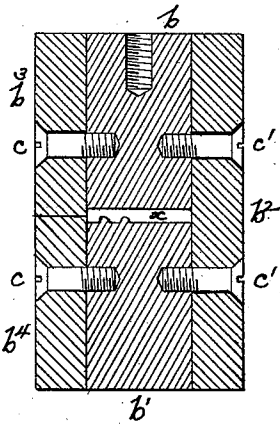

FIG. 3.

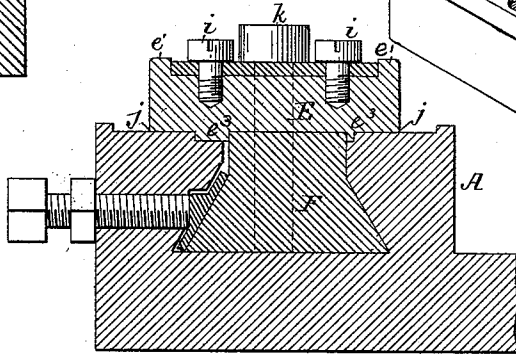
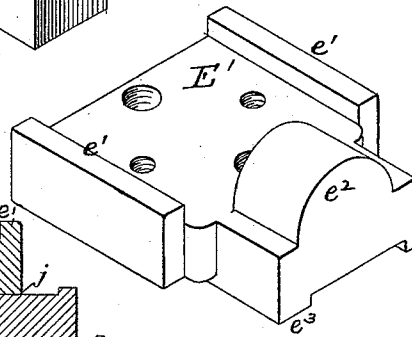

FIG. 6.



Witnesses:
Alex. Barkoff
R. Schleicher.

Inventor:
George H. Ziegler
by his Attorneys
Howan & Howan

UNITED STATES PATENT OFFICE.

GEORGE H. ZIEGLER, OF PHILADELPHIA, PENNSYLVANIA, ASSIGNOR TO
THE AMERICAN TYPE FOUNDERS COMPANY, OF NEWARK, NEW
JERSEY.

TYPE-CASTING MACHINE.

SPECIFICATION forming part of Letters Patent No. 523,301, dated July 17, 1894.

Application filed May 29, 1893. Serial No. 476,937. (No model.)

To all whom it may concern:

Be it known that I, GEORGE H. ZIEGLER, a citizen of the United States, residing in Philadelphia, Pennsylvania, have invented certain
5 Improvements in Type-Casting Machines, of which the following is a specification.

The object of my invention is to so construct the mold of a type casting machine, that it can be readily adjusted and can be
10 quickly removed and replaced when necessary, a further object of the invention being to guide the outer portion of the bodypiece independently of its slide so that it will always align with the mold, as it will be understood
15 in this class of type casting machines the adjustments are very delicate and the parts must align so as to produce square type.

In the accompanying drawings:—Figure 1, is a plan view of sufficient of a type casting
20 machine to illustrate my invention. Fig. 2, is a longitudinal sectional view on the line 1—2, Fig. 1. Fig. 3, is a transverse section on the line 3—4, Fig. 1. Fig. 4, is a perspective view of the mold section. Fig. 5, is a section on the
25 line 5—6, Fig. 2, and Fig. 6, is a detached perspective view of the body piece block.

A is the bed of the machine, on which is fixed a back or extension A' to support the upper portion of the mold. In the face of
30 the back and in the bed is an undercut groove in which fits the projecting portion *g*, of the base B² of the mold; the base B² is secured to the back by confining screws *a'* and to the
35 upper portion of the back is a set screw *a*² which bears against the mold and when the screws *a'* are loose can be turned to force out the upper portion of the mold and tend
40 to close the outer edge of the opening *x* of the mold in which the type is cast; by this means the mold can be adjusted to take up for wear, insuring clean, sharp edged type.

The mold proper B' is so arranged that its several parts can be adjusted or replaced
45 readily and is composed of the upper and lower sections *b b'*, which have projections adapted to a vertical groove *e* in the base B² and are confined to said base by screws *f*. The lower section *b'* is practically fixed, but
50 the upper section *b* can be vertically adjusted by the adjusting screw *d*², which is confined

in a slotted plate, *d*³, secured to the base B², on turning this screw the section *b* can be raised or lowered. The jet plates *b*³ and *b*⁴
are secured to their respective sections *b, b'*, 55 by screws *c*. The face plate *b*² extends the full length of the mold proper and is secured to both sections *b, b'*, by screws *c*; the holes in the plate *b*² for the screws are somewhat larger than the screws to allow for adjust- 60 ment.

The face plate *b*² extends across the end of the cavity *x* where quads and spaces are cast, but is shaped, when characters are cast, to allow the matrix free action. The apron *d* is
65 secured to the plates *b*³ and *b*⁴ by confining screws *d'*.

In order to insure the proper alignment of the body piece with the mold I so arrange it that its other end slides in ways on the bed, 70 A of the machine so that it is impossible, after the parts are once aligned to move them out of line; the mold and body piece can be removed but when placed in position they will align without adjusting. The body piece is
75 secured to a block E' by screws *i, i*, the block has ribs *e'*, which extend up at each side of the body piece and has a head *e*³ against which the body piece rests so that the body piece is locked firmly to the block; the block may 80 form part of the body piece in some instances. This block slides upon ways *j, j*, on the frame A and has a tongue *e*³ on its underside adapted to a slot in the bed preventing the block from moving laterally and always keeping it in
85 line with the mold. This block is confined to the operating slide or bar F by confining screws *k, k*, which in the present instance pass through the body piece as well as the block and the block is recessed to receive the
90 upper portion of the slide or bar.

It will be seen when it is wished to detach the mold and body piece from the machine they can be readily detached without losing the adjustment of the parts as both parts are
95 adapted to the bed of the machine and the body piece is simply moved by a slide.

The mechanism for reciprocating the slide or bar carrying the body piece, as well as the mechanism for operating the vertically slid-
100 ing plate, I, to open and close the mold, is fully illustrated and described in a pending

application filed by me, on June 25, 1892, Serial No. 437,946, and, therefore, will not need detailed description, as the parts claimed in the application refer particularly to the mold
5 and body piece.

I claim as my invention—

1. The combination of the mold, the bed to which the mold is secured, a slideway on said bed, a body piece adapted to the mold, a block
10 on the body piece adapted to the slideway, with a reciprocated bar attached to the block and means for reciprocating the bar and a guideway for said bar, substantially as described.

15 2. The combination in a type mold, of the base section B^2 carrying upper and lower sections between which the type is molded, a body piece adapted to slide between said sections, screws for locking the said base section
20 to the machine and a set screw on the machine bearing upon the base section so that on turning the set screw the base section can be forced out and the mold strained sufficiently to take up the wear at the mouth of
25 the mold, substantially as described.

3. The combination in a type mold, of the base secured to the bed of the machine, the independent upper and lower sections b, b' ,
30 confining screws f , confining said sections to the base, and an adjusting screw d^2 for adjusting one mold section in respect to the other, substantially as described.

4. The combination in a base section B^2 , of the mold, screws securing the said section to
35 the machine, a mold section B' vertically adjustable on said section B^2 , said mold section being made up of upper and lower blocks b, b' , jet plates b^3, b^4 and face plates b^2 , substantially as described.

40 5. The combination in a mold, of the base section B^2 , the upper and lower mold sections b, b' , set screws f passing through slots in the

base section and into the mold sections b, b' , jet plates b^3, b^4 secured to their respective mold sections, a face plate b^2 , with screws c'
45 passing through enlarged holes in the face plate b^2 and into the upper and lower sections of the mold, substantially as described.

6. The combination of the base of the machine, the extension A' thereof, the mold base
50 B^2 , lower confining screw a and the upper confining screw a' for confining the mold base to the machine, and a set screw threaded into the extension and bearing against the upper portion of the mold base, the mold B' , con-
55 fining screws f passing through slots in the mold base into the mold, a projecting plate on the base, and a set screw confined to said base and threaded into the mold so that the mold can be vertically adjusted, substantially
60 as described.

7. The combination of the mold, the body piece, the block secured to the body piece, said block having a head and side flange and a tongue, said block adapted to ways on the
65 bed of the machine, with means for operating the body piece, substantially as set forth.

8. The combination in a type casting machine, of the base grooved to receive the mold
70 section and provided with a slide-way, a mold adapted to said grooved base, with means for securing the mold in its adjusted position, and a body piece adapted to the mold, a block on said body piece adapted to the slideway,
75 an operating bar detachably secured to the body piece and block, substantially as described.

In testimony whereof I have signed my name to this specification in the presence of two subscribing witnesses.

GEORGE H. ZIEGLER.

Witnesses:

WILLIAM A. BARR,
JOSEPH H. KLEIN.