

No. 809,548.

PATENTED JAN. 9, 1906.

L. B. BENTON.
MATRIX AND PUNCH CUTTING MACHINE.

APPLICATION FILED FEB. 17, 1899.

3 SHEETS—SHEET 1.

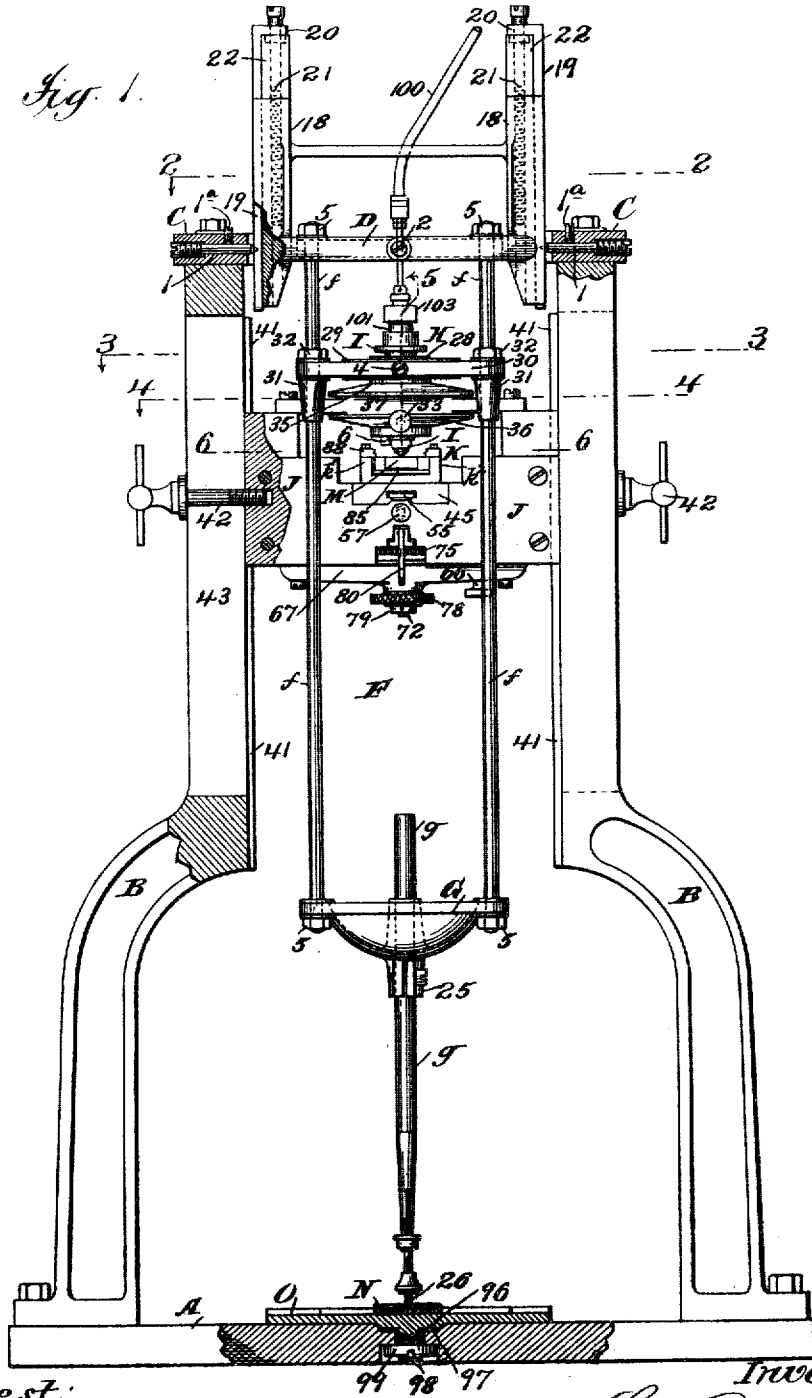

Attest:
Geo H. Holt
T. F. Kehoe

Inventor:
Linn Boyd Benton
 By *Philip Phelps Sawyer*
Att'y

L. B. BENTON.
MATRIX AND PUNCH CUTTING MACHINE.

APPLICATION FILED FEB. 17, 1899.

3 SHEETS—SHEET 2.

Fig. 2.

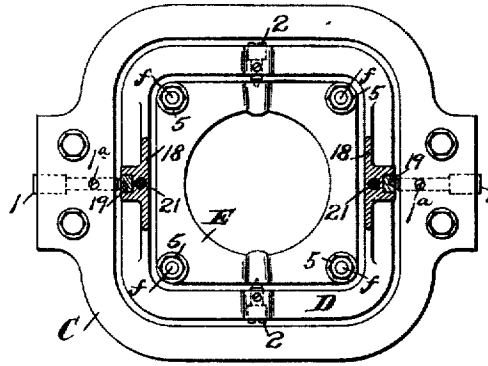

Fig. 3.

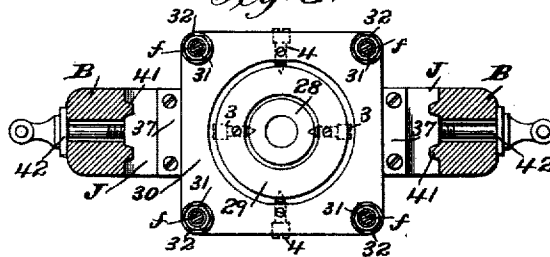

Fig. 4.

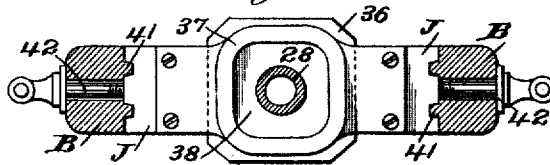
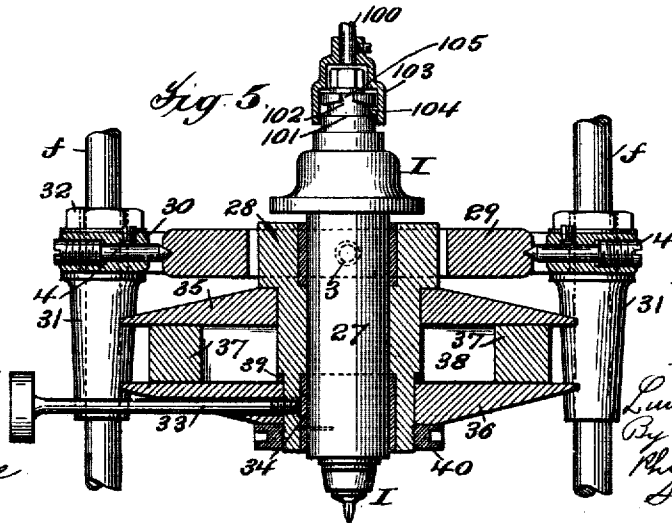

Fig. 5.



Attest:
Geo. M. Botsch
J. P. Kehoe

Inventor:
Linn Boyd Benton
By
Philip Phelps &
Sawyer
Attys

L. B. BENTON.
MATRIX AND PUNCH CUTTING MACHINE.

APPLICATION FILED FEB. 17, 1899.

3 SHEETS—SHEET 3.

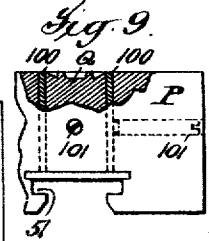
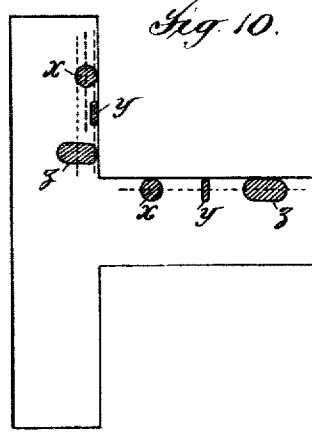
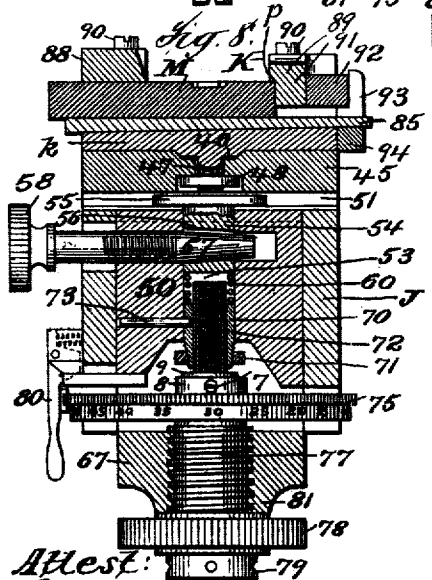
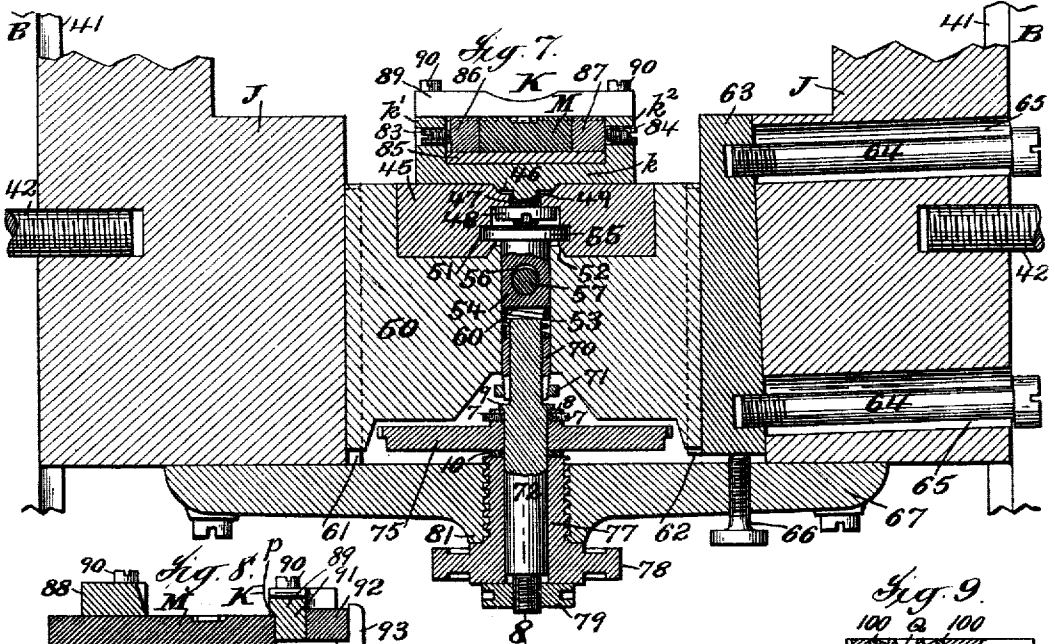
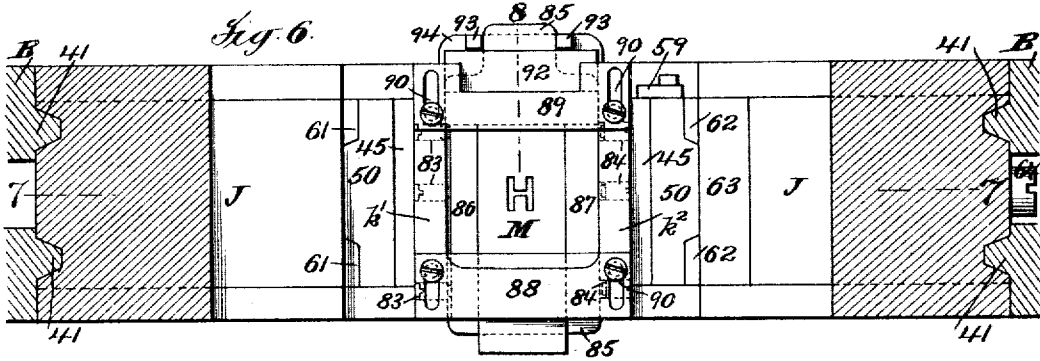

Attest:
Geo. H. Botts
O. G. Schae

Inventor
Linn Boyd Benton.
By
Philip Phelps
& Sawyer
Attys

UNITED STATES PATENT OFFICE.

LINN BOYD BENTON, OF NEW YORK, N. Y., ASSIGNOR TO AMERICAN TYPE FOUNDERS COMPANY, OF NEW YORK, N. Y., A CORPORATION OF NEW JERSEY.

MATRIX AND PUNCH CUTTING MACHINE.

No. 808,548.

Specification of Letters Patent.

Patented Jan. 9, 1906.

Application filed February 17, 1899. Serial No. 705,785.

To all whom it may concern:

Be it known that I, LINN BOYD BENTON, a citizen of the United States, residing at New York city, county of Kings, and State of New York, have invented certain new and useful Improvements in Matrix and Punch Cutting Machines and the Like, fully described and represented in the following specification and the accompanying drawings, forming a part of the same.

This invention relates especially to machines for cutting cameo or intaglio designs from an enlarged pattern to form punches or dies, and more particularly to machines of this class for cutting type-punches from which matrices for casting printing-type are formed or for cutting the matrices themselves, although many features of the invention may be used also in machines for engraving or cutting other raised or sunken designs or for reproducing a design from a pattern otherwise than by cutting.

I aim especially at the production of a simple and efficient matrix-cutting machine by which type-matrices may be cut accurately and the size, form, and depth of the matrix determined by simple and efficient adjustments.

To this end the invention includes, in addition to various features of construction of more general application, improved means for holding matrix-bars during the cutting and assuring the proper position of the matrix and other specific features and combinations of parts in matrix-cutting machines.

The invention has been made in connection with a machine resembling in general construction that shown in my prior Letters Patent No. 332,990, and it will be illustrated and described as thus applied; but it will be understood that many of the features of the invention are applicable also in machines of other form than that of said Letters Patent.

For a full understanding of the invention a detailed description of a machine embodying all the features of the same as applied in their preferred form will now be given in connection with the accompanying drawings, forming a part of this specification, and the features forming the invention will then be specifically pointed out in the claims.

Figure 1 is a front elevation, partly in sec-

tion, of the machine with the parts in central position. Fig. 2 is a horizontal section on the line 2 of Fig. 1, showing the universal-joint support of the swinging frame. Fig. 3 is a horizontal section on the line 3 of Fig. 1, showing the universal-joint connection of the tool-holder. Fig. 4 is a horizontal section on the line 4 of Fig. 1. Fig. 5 is a vertical section of the parts shown in Figs. 3 and 4, the section being taken on the line 5 of Fig. 1. Fig. 6 is a sectional plan of the matrix-block holder, the section being taken on the line 6 of Fig. 1. Fig. 7 is a longitudinal vertical section of the same on the line 7 of Fig. 6. Fig. 8 is a transverse vertical section of the same on the line 8 of Figs. 6 and 7. Fig. 9 is a detail view showing a modified form of work-holder for supporting a block from which a type-punch is to be cut. Fig. 10 is a diagrammatic view illustrating compensating tracers for use in cutting matrices or type-punches for condensed or extended type.

In the drawings, A is the base or table on which the pattern-holder is mounted and from which rise two standards B, forming supports for the operating parts of the machine. On the top of the supports B is rigidly secured an open horizontal frame C, preferably of a rectangular form, as shown, within which is a second similar frame D, pivotally mounted on the frame C in the following manner: The frame D has two upwardly-extending bars 18, arranged at opposite sides of the frame and preferably tied together for stiffness, as shown, which bars are grooved on the outer sides to receive bars 19, having at their upper ends arms 20, extending over bars 18 and through which pass vertical adjusting-screws 21, turning without vertical movement in arms 20 and working in screw-threaded holes in the bars 18 on the frame D, so that the frame D is moved up or down on bars 19 as screws 21 are turned. The bars 19 are pivoted on pivot-screws 1 in frame C, which screws preferably have enlarged screw portions for adjustment and are locked in position by screws 1^a, tapped through the top of the frame C and engaging the reduced unthreaded portions of the pivot-screws. A very efficient and durable pivot-mounting is thus secured, and the exact alignment of the pivots on opposite sides may

readily be secured by boring the unthreaded openings through in line and then forming the enlarged screw-threaded outer portions. Between the top of the bars 18 and the arms 5 20 of the bars 19 are placed bearing-blocks 22, against which the bars 18 are set up by screws 21, the length of these blocks thus determining the position of the frame D relative to the pivots 1 and frame C and different blocks being used for the various adjustments. 10

Within the frame D and pivoted to said frame so as to move at right angles to the movement of the latter on pivots 1 is a plate 15 E, by which is suspended the swinging frame F, which carries the tracer and cutter. The plate E is rectangular in form and is pivoted to the frame D by pivot-screws 2, passing through the frame D, these screws preferably 20 being of the same construction and locked in position by screws in the same manner as described above in connection with pivots 1. As will be seen from Fig. 2, the pivots 1 and 2 of the frame D and plate E thus form a universal joint for the swinging frame F. The 25 upper and lower plates E G of the swinging frame F are connected by four vertical rods *f*, arranged at the corners of plate E, these rods being shown as secured in plates E G by nuts 5. The plate G carries a tracer-rod *g*, adjustably secured to said plate by clamp 25, the lower end of the tracer-rod *g* carrying the tracer-point 26, which may be adjustably secured thereto in any suitable manner, as 30 usual in this class of machines.

The cutting-tool I, which may be of any suitable construction, is free to rotate in a sleeve 27, carried by a socket piece or ring 28, pivoted in a ring 29 by pivot-screws 3 in the 40 ring 29, the socket 28 being mounted axially with the frame D. The ring 29 is in turn pivoted in an outer plate or ring 30 by pivot-screws 4, so as to permit a movement of the ring 29 at right angles to its movement on 45 pivots 3, thus forming a universal joint for ring 29, corresponding to the universal-joint mounting of plate E and the swinging frame F, as shown in Figs. 2 and 3. The plate 30 has at each of its four corners a depending 50 sleeve 31, secured to it by nuts 32, and through which sleeves pass freely the rods *f* of the swinging frame F, by which construction the movement of the swinging frame is imparted to the cutting-tool, while the frame 55 and plate 30 are free to move up and down relatively to each other. The sleeve 27 is held stationary in the socket 28 by a thumb-screw 33, screwing into the socket and bearing against a wing formed on a split ring 34 in the lower end of the socket 28. The socket 60 28 has fixed to it two plates 35 36, adapted to move with the socket 28 in a horizontal plane on the upper and lower surfaces of a horizontal plate 37, secured to the block J, 65 which is mounted on standards B, as herein-

after described. The plate 37 has an opening 38 surrounding the socket 28 between plates 35 36, thereby allowing free sidewise movement of the socket 28, due to the movement of the swinging frame F, while holding 70 it in the same horizontal plane during said movement. The upper plate 35 may be secured to the socket 28 in any suitable manner, so as to rest and move on the upper surface of the plate 37, while the lower plate 36 75 is fitted against a bearing-ring 39, abutting against a shoulder on the socket 28, this ring 39 being ground or rubbed down until the plate 36 bears against the plate 37 in such a manner as to assure an easy movement of the 80 plates 35 36 on the plate 37, while holding the socket accurately in position. The lower end of the socket 28 is screw-threaded to receive a nut 40, by which the plate 36 is held up against the plate 37 and ring 39. The 85 proper position of cutting-tool I in the socket 28 is assured by allowing the sleeve 27 to drop against an abutment 6, secured to the bottom edge of the socket 28 and which acts as a stop for the sleeve, as shown in Fig. 1. 90 The cutting-tool I is rotated by means of a flexible shaft 100, connected to any source of power and in any convenient manner. I have shown a simple and convenient means for attaching the shaft 100 to the tool I for 95 rotating the same, in which the tool I has at its upper end a head 101, having a groove 102, extending through about half the circumference of the head 101. Upon the head 101 I place a cap 103, fast to the end of the 100 shaft 100 and having a pin 104 on its inner surface adapted to enter the groove 102 at the cut-away portion 105. The pin 104 having been entered through the opening 105, 105 the rotation of the shaft will move it in the groove 102 until it strikes the end wall of the groove, when the cutting-tool I will rotate with the shaft 100.

The block J, by which the tool-holder is supported through plate 37, is adjustably 110 mounted on the standards B, the outer edges of the block J being grooved to receive and slide on guide-ribs 41 on the inner faces of standards B, and the block is clamped in 115 adjusted position by thumb-screws 42, which pass through vertical slots 43 in the standards B. The block J carries also the work-holder, and by the adjustment of the block J the tool-holder and work-holder may be ad- 120 justed relatively to the pivots 1 of the frame F for any desired size of matrix or type punch relatively to the pattern, this adjustment determining the proportional reduction of the pattern in cutting the matrix or punch.

As shown in Figs. 1 and 6 to 8, the work 125 or matrix holder K is mounted on a supporting-block 45, which slides into a groove in the top of a vertically-adjustable block 50, set into block J, by the adjustment of which block 50 the block 45 and matrix-holder K 130

are moved vertically to position the matrix-block vertically relatively to the cutting-tool I, and thus determine the depth of cut. The block 45 has a horizontal T-shaped groove 51 on its under side running its entire length, and the lower face of the block is inclined on opposite sides of the groove to move on a correspondingly-inclined seat 52 on the upper surface of the groove in block 50. The block 50 has also a central vertical opening 53, extending through the block and into the upper part of which is fitted a short bolt 54, having a head 55, entering the T-shaped groove 51 and by which the block 45 is held down in the groove in block 50. This bolt 54 has a transverse opening 56, which receives the tapered end of a screw 57, passing freely through the portion of block J outside block 50 and working in a screw-thread in block 50, as shown in Fig. 8, and having a milled head 58 outside block J. By turning the screw 57 by head 58 the inner tapered end of the screw will be forced in over the bottom of the opening 56 in the bolt 54 and force the bolt 54 down, so that its head 55 will draw the block 45 firmly down onto the block 50. As the groove 51 runs the entire length of the block 45 and the blocks 50 and J are grooved through to the front of the machine for the block 45, the block 45 and work-holder K can readily be removed from under the cutting-tool and from the block J and replaced for the substitution and positioning of a new matrix-bar, the screw 57 being loosened for the removal of the block and tightened again to secure the parts in position. A spring 60 is placed in the opening 53 underneath the bolt 54, the object of said spring being to force the bolt 54 upwardly as the screw 57 is withdrawn, so as to hold the head 55 of the bolt 54 in position to readily enter the groove 51 of the block 45 as the latter is slid into position. When the block 45 reaches its position in the block 50, its rear end abuts against a stop 59, secured to the rear side of the block 50, thus assuring the correct forward and rear position of the block 45 relatively to the cutting-tool I, while its proper right and left position is assured by its fit in block 50 and the engagement of head 55 in the groove 51.

The supporting-block 50 is fitted to slide vertically between ribs 61 on the block J and ribs 62, formed on a wedge-block 63, which is adjustably held in position by threaded bolts 64, passing through slots 65 in the block J, the heads of the bolts 64 bearing against the outer face of the block J and the threaded inner ends of the bolts engaging threaded openings in the wedge-block 63. The wedge-block 63 is adjusted vertically by an adjusting-screw 66, passing upward through a bar 67, secured to the lower face of the block J and across the opening in which block 50 slides. By loosening the bolts 64 and setting up the screw 66 the wedge-block 63 may be

moved up so as to take up all wear between it and the block 50, and thus prevent any side-wise movement or looseness of block 50.

The means for adjusting the block 50 and work-holder K vertically to determine the depth of the cut in the matrix-bar are as follows: In the opening 53 of the block 50 and directly beneath the bolt 54 is a sleeve 70, the lower end of which is split, tapered, and screw-threaded externally to receive a binding-nut 71, the upper end of the sleeve 70 forming a bearing for the spring 60, before referred to. This sleeve 70 is screw-threaded internally for its entire length with a very fine thread and is entered by a similarly screw-threaded bolt 72. The sleeve 70 is held fast to the block 50 and prevented from rotating by a pin 73. (See Fig. 8.) Below the lower edge of the block 50 and fastened to the bolt 72 by set-screws 7 is a micrometer-disk 75, having a hub 8, which bears against the under side of a shoulder 9, formed on the bolt 72. Below the disk 75 and surrounding the bolt 72 is a screw-threaded sleeve 77, threaded in the bar 67 and working against a washer 10 between it and the under side of the disk 75. This sleeve 77 has a milled head 78 for turning it, and the lower end of the bolt 72 is turned down and threaded outside the head 78 and provided with a nut 79 below the head 78. A spring-pressed holding-latch 80, pivoted to lugs on the block J, is provided for holding the micrometer-disk 75 from accidental rotation, and this catch serves also as an index for the micrometer-disk divisions as the latter is turned. The sleeve 77 acts to bring the work up to and withdraw it from the tool. In raising block 50 as the sleeve 77 is screwed up it acts through disk 75 and its hub 8, bearing against shoulder 9 of the bolt 72, to move the bolt 72 and sleeve 70 upward, and thus through pin 73 also moves block 50 upward until the head 78 abuts against the hub 81 on bar 67 when the machine is to be put into operation, and when the sleeve 77 is screwed down it withdraws the matrix-bar from the tool by drawing bolt 72 and block 50 down by the nut 79 on the outer end of bolt 72. The sleeve 77 is shown in its highest position.

The adjustment to determine the depth the cutting-tool shall enter the matrix-bar M—that is, the depth to which the latter shall be cut—is obtained by the micrometer-disk 75. As the disk 75 is pinned to the bolt 72 by pins 7, the turning of the disk 75 to the left, the catch 80 having been released, will also turn the bolt 72 to the left, and the sleeve 70, being held from rotating by the pin 73, will thus be raised by the reverse action of the upper end of bolt 72, and the block 50 thus be raised, and the rotation of the disk 75 in the opposite direction will similarly lower the block 50, and thus the matrix-bar may be accurately positioned vertically to secure

the depth of cut desired, the graduation on the disk 75, engaged by the catch 80, determining the depth of cut of the matrix-bar. The internal screw-threads of the sleeve 70, as before stated, are very fine, preferably fifty to the inch, so that a very fine adjustment of the depth of cut is secured, and any looseness or play between the sleeve 70 and bolt 72 may be taken up by the binding-nut 71 on the split tapered end of the sleeve 70, the nut 71 being screwed farther up on the end of the sleeve to tighten it onto the bolt 72, and thus take up any wear which may occur and assure the accurate operation of the parts. It will be understood that the matrix-bar is adjusted for the depth of cut desired by the disk 75, while the bar is withdrawn from the tool by the sleeve 77, and the matrix-bar is then moved up against the tool by screwing up the sleeve 77.

In making matrices for type-casting machines it has heretofore been necessary to trim the matrix-bar after the letter has been cut to secure the desired position of the matrix relatively to the bar and the proper position of the cast letter to the body of the type. The rear edge and one side of the bar are thus trimmed for position in making matrices for the ordinary steam casting-machines and the rear end and the opposite side in making matrices for the automatic machines now used quite largely. The work-holder shown in the drawings is designed to do away with these objections by providing for the adjustment of the matrix-bar before the cutting of the letter, so that the cut matrix-bar may be taken from the holder and placed in casting-machines of either of the before-mentioned classes without trimming. For this purpose the following construction is used, as shown especially in Figs. 6 to 8. The work-holder K is formed with a base k , having vertical side flanges k' k^2 , each of the flanges being shown as having three adjusting-screws 83 84, although this number may be varied, if desired. Between the flanges k' k^2 and resting on the base k is a wedge-plate 85, moving longitudinally of the matrix-bar on which rest the matrix-bar M, and two gage-blocks 86 87, acted on, respectively, by the screws 83 84 and between which the matrix-bar is placed. Above the matrix-bar are two plates 88 89, which form a top gage or stop for the matrix-bar and which are fastened to the flanges k' k^2 by screw-and-slot connections 90 for adjustment to accommodate different lengths of matrix-bars. The rear edge of the matrix-bar M is set against a depending portion 91 of the plate 89 between the side gages 86 87 and which forms a rear or end gage for the matrix-bar, the rear edge of the latter taking under a shoulder p on the rear gage 91, forming a part of the top gage. The rear gage 91 abuts against a block 92, held in position by upwardly-extending fingers 93 on

a bar 94 fast to the rear side of the base k of the holder and between which the reduced rear end of the wedge-plate 85 passes. For different lengths of matrix-bars the block 92 is changed to a greater or less width and the position of the plates 88 89 is changed to correspond with such length. When the matrix-bar M is to be used on the automatic casting-machine, the block 87 is placed against the inner surface of the adjacent flange—that is, the flange k^2 —the screws 84 being withdrawn from engagement with said block, and the matrix-bar is placed in the holder underneath the plates 88 89 and on the wedge-plate 85. The block 86 is now set up against the opposite edge of the matrix-bar by the screws 83 and the wedge-plate 85 forced in from front to rear of the machine or to the right in Fig. 8, so as to press the matrix-bar against the top gages 88 89, and this movement of the wedge-plate 85 also forces the matrix-bar rearward against the rear gage 91, thus assuring the accurate position of the top face of the matrix-bar and its accurate endwise position. The wedge-plate 85 thus forms a clamp by which the matrix-bar is forced endwise and vertically and held in proper position in these directions. When a matrix-bar is to be cut for a steam casting-machine, the block 86 will be placed against the other flange k' , the screws 83 being withdrawn out of engagement with said block, and the matrix-bar M set up against the block 86 by the screws 84 acting on block 87. It will be seen that this adjusting of the blocks 86 87 takes the place of the trimming of the matrix-bars heretofore performed after cutting, and the bars are taken from the holder K ready for use in either of the type-casting machines in use. It will be understood that all the matrix-bars are made accurately to the same width for use with blocks 86 87 of a single width, but that blocks 86 87 of different widths may be used for different sizes of matrix-bars. In some cases—as, for instance, when matrices are cut for different type-foundries employing steam type-casting machines—it may be desired to leave some metal for side trimming of the matrices to suit individual tastes in respect to the type; but even in that case the accurate positioning of the matrix relatively to the end and side edges of the matrix-bar secured by my holder is of great value.

The base k of the work-holder may be formed integral with the block 45 or mounted thereon in any suitable manner if only matrices for ortholineal type are to be cut; but I preferably mount the work-holder so that matrices inclined in either direction at any angle desired may be cut from ortholineal patterns for italicizing type or other purposes, with the base of the matrix parallel with the base-line of the matrix-bar. For this purpose, as shown in Figs. 1 and 6 to 8, the base k of the work-holder K is mounted

on the supporting-block 45 in such a manner as to allow it to rotate thereon through a complete revolution in a horizontal plane, so that the matrix-holder and matrix-bar may be fixed in any angular position around the axis of the machine—that is, around the central line of the machine connecting the tracer and central point of the frame D or plate E. In the construction shown the base *k* of the holder K is shown as provided on its under side with a circular stud 46, formed with an inclined edge and seated in a correspondingly-inclined opening 49 in the top of the block 45. The stud 46 has a depending shank 47, passing through an opening in the block 45, and onto which is screwed a nut 48, which may be set up against a shoulder about the opening in the block 45, the nut 48 being in line with the slot in the block 45 which receives the bolt-head 55, so that the nut 48 may be manipulated when the block 45 is removed from block 50. It will be seen that by loosening the nut 48 on the shank 47 the base *k* and work-holder K may be turned on the block 45 to assume any desired position in a horizontal plane relatively to the other parts of the machine, and by tightening the nut 48 the work-holder will be locked in adjusted position. The inclined surfaces on the stud 46 and about opening 49 compensate for wear and secure the desired firm lock against accidental rotation of the work-holder. It is necessary also to adjust the pattern at the same angle as the work-holder or matrix-bar. This may obviously be done by any means for holding the pattern in the proper angular position; but preferably I make the pattern-holder adjustable by rotation, so that the pattern is secured in the holder in the same manner as in cutting ortholineal matrices and the adjustment of the pattern-holder depended upon to position the pattern. For this purpose the pattern-holder O is shown as mounted on the table A in the same manner as the matrix-holder K on the supporting-block 45, the pattern-holder O having on its lower surface a circular inclined stud 96 in opening 97, forming an inclined seat on the table A, and a screw-threaded shank 98, passing through an opening in the table and having locking-nut 99. For convenience in adjusting the matrix-holder K and pattern-holder O and to assure accurate adjustment the block 45 and the table A will preferably be provided with circular scales (not shown) for showing the degrees through which the work-holder and pattern-holder are rotated. By thus adjusting the work-holder and pattern-holder angularly around the axis of the machine or frame F and adjusting frame D vertically by screws 21 and substitute blocks 22, so as to position the pivots 2 in a plane more or less above the plane of pivots 1, a letter-back sloped or italicized, as desired, may be cut

from an ortholineal pattern. The same result could be secured by turning the frame F angularly around the axis of the machine, the frame D being adjusted vertically, as above described; but such an adjustment of the frame F is not convenient. It will be understood that back-sloped or italicized letters may be cut from ortholineal patterns by adjusting the pivots and the pattern, as above described, without adjusting the work; but in that case the matrix-bar must be squared up after the letter is cut, and therefore it is preferable to adjust the work at the same angle as the pattern.

For cutting type or other punches instead of matrices the matrix-holder K is not required, but all the other features of the machine are retained, a suitable punch-holder being simply substituted for holder K. Such a punch-holder is shown in Fig. 9, in which the holder P consists of a block having the T-groove 51 and the inclined walls about its base opening, as in case of block 45, so that it may be slipped into place in block 50 in place of block 45. The punch-holder P is shown as having the usual clamping-pieces 100 and set-screws 101, by which the punch Q is centered and held in position. The construction shown in Fig. 9 does not provide for rotating the punch-holder P; but it is obvious that the punch-holder P may be made like the base-plate *k* of matrix-holder K and adjustably secured in the top of block 45 by the nut 48 in the same manner as above described in connection with the matrix-holder.

As above stated, the adjustment of the block J with the work-holder K and cutting-tool determines the proportional reduction from the pattern by varying the distance of the cutting-tool from the pivots 1 2 of the swinging frame F, thus increasing or decreasing the extent of movement of the cutting-tool in any direction for a given movement of the tracer 26, both components of the tracer's movement being thus correspondingly modified. The machine shown permits adjustment also for cutting punches or matrices for condensed or extended type—that is, type in which the width of the letter is decreased or increased, the height remaining the same. This requires the non-proportional reduction of the pattern, which is secured by modifying the two components of the tracer's movement independently, and this result is secured by the up-and-down adjustment of the frame D relatively to pivots 1 by moving the bars 18 up and down on pivot-bars 19, as above described, this adjustment varying the position of the pivots 2 of the swinging frame relatively to the matrix-holder K and cutting-tool, which are stationary during such adjustment, the rods *f* moving freely through the sleeves 31. I thus increase or diminish the distance between the cutting-tool and the pivots 2 of the swinging frame F, so as to in-

crease or diminish the extent of right- and-left movement of the cutting-tool for a given movement of the tracer 26, the forward-and-rear movement of the frame remaining unchanged, as the position of pivots 1 relatively to the cutting-tool is unchanged. The right and left component of the tracer's movement is thus increased or diminished relatively to and independently of the forward and rear component and the letter cut in the matrix-bar or type-punch correspondingly extended or condensed. Raising the frame D will obviously increase the movement of the cutting-tool and extend the letter and lowering the frame D will decrease the movement of the cutting-tool and condense the letter. For this condensation and extension of ortholineal designs the work-holder and pattern-holder are kept in normal position with the lines of the pattern parallel with lines of pivoting. If the work and pattern be turned angularly, the result is the inclining of the design cut as above described. The frame G, carrying the index-rod *g*, moves with the frame F during this adjustment of the frame D, the index-rod *g* being adjustable in the frame G to compensate for this movement.

Any suitable form of tracer may be used in this machine, and in proportional reduction from the pattern I preferably employ the usual tracer having a circular tracing-point by which the path of the vertical axis of the tracer which determines the path of movement of the cutting-tool is exactly at the same distance from all lines of the pattern followed by the tracer. Such a circular tracer also may be used in non-proportional reductions from the same pattern to produce condensed or extended type, as above described; but the circular tracer produces in such non-proportional reductions a change in the style of the type which is not desired in condensed or extended type by reducing or increasing the width or weight of each of the vertical lines of the letter as well as the width of the letter as a whole, so that the vertical lines of condensed or extended letters cut with such circular tracer are narrower or wider than the horizontal lines. While this effect may be disregarded or otherwise corrected and the circular tracer used, it may interfere with the desired similarity in appearance of different varieties of type of the same style, especially in the larger type, and therefore in such non-proportional reductions to produce condensed or extended type of the same style as type formed from the same pattern by proportional reduction I preferably use a tracer of such form as to compensate for the difference between the ratios of reduction of the components of the movement of the tracer by which the horizontal and vertical lines of the letter are produced—that is, between the right-and-left and the forward-and

rear movements of the tracer in the machine shown. The tracer I employ for this purpose is oblong and preferably with straight sides and round ends, the two diameters or horizontal dimensions of the tracer-point being such that the axis of the tracer as the latter follows the vertical lines of a sunken or matrix pattern-letter moves in a path nearer to or farther from the line than in following the horizontal lines according as the horizontal dimension of the type is decreased or increased to condense or extend the letter cut, while in following a raised or type-pattern letter this is reversed and the axis of the tracer runs nearer the vertical lines than the horizontal lines in forming an extended letter, and farther from the vertical lines than the horizontal lines in forming a condensed letter. This reversal of the position of the tracer-axis in following a matrix and type-pattern will be clear if it be borne in mind that the object of the oblong tracer is to increase or decrease the width of the vertical line-space in the pattern, so as to compensate for the ratio of condensation or extension of the letter as a whole, and thus secure the same proportional reduction of the width or weight of the vertical lines as of the horizontal lines, and that the width of the line-space movement of the tracer-axis in a matrix is increased or decreased by reducing or increasing the distance of the axis from the matrix-wall, while in tracing a type increasing this distance of the axis from the type-line increases the width of the line-space movement of the tracer and decreasing this distance decreases this movement. It will be understood that in either case the horizontal dimension of the tracer that determines the distance of its axis from the line of the letter in tracing the horizontal lines—that is, the forward and rear dimension in the machine shown—will be the same as that of a circular tracer for the proportional reduction determining the height of the letter and the weight of the horizontal lines and the other horizontal dimension of the tracer which determines the distance of the axis from the line of the letter in tracing the vertical lines—that is, the right-and-left dimension in the machine shown will be increased or diminished relatively to such proportional dimension to secure the result desired.

The increase or decrease of the right-and-left dimension of the tracer relatively to the forward-and-rear dimension will depend upon the weight of the vertical lines or width of the line-space in the pattern, the increase or decrease being such that it will compensate for the decrease or increase of the weight of the vertical lines which would result from using a tracer of the same right-and-left and forward-and-rear dimensions, which obviously depends upon the ratio of condensation or extension. In tracing a matrix for

cutting a condensed letter the right-and-left dimension of the tracer will be decreased relatively to its forward-and-rear dimension to such an extent that the difference between the two dimensions bears to the width of the vertical line-space of the pattern the ratio of condensation, thus widening the path of movement of the axis of the tracer in following the vertical lines so as to compensate for the condensation. In tracing a matrix for cutting an extended letter the right-and-left dimension of the tracer will be increased over the forward-and-rear dimension to such an extent that the difference between the two dimensions bears to the width of the vertical line-space the ratio of condensation, so as to decrease the width of the path of movement of the tracer to compensate for the extension. In tracing type-patterns the proportion is to be the same, but the right-and-left dimension of the tracer is increased to compensate for condensation and decrease to compensate for extension. In this calculation it is obvious that the width of the line-space to be used is not the actual width of the vertical lines, but the width of the path of movement of the axis of a proportional tracer in following these lines, as this path of movement determines the movement of the cutting-tool and is, in fact, the pattern line-space. This line-space equals the actual line width minus the diameter of the proportional tracer in the case of a matrix-pattern and the actual line width plus the diameter of the proportional tracer in tracing a type-pattern. As above stated, the forward-and-rear dimension of the tracer is to be made equal to the diameter of the proportional tracer, and consequently the calculation of the line-space may be based on this.

In Fig. 10 I have shown in diagram for the purpose of illustration a matrix-pattern block letter H with a circular tracer-point for proportional reduction and tracer-points for non-proportional reductions for producing condensed and extended letters from the same pattern and with the same height reduction, the tracers being shown in position in tracing the same vertical and horizontal lines, from which illustration the construction and action of my compensating tracers will be clear. The tracers are illustrated in this drawing as made for a condensation or extension of about one-fourth. In this figure, x is the circular tracer for proportional reduction, y the tracer for cutting the condensed letter, and z the tracer for cutting the extended letter. As shown by the dotted lines, which indicate the paths of movement of the axes of the tracers, the axes of all the tracers move in the same line in tracing the horizontal lines, so that the extent of the forward and rear movements of the tracers in following the pattern is the same, and the proportional reduction of tracer x is preserved so far as the height

of the letter is concerned. In following the vertical lines however, as shown by these dotted lines the axis of tracer y moves in a path nearer the wall of the line-space than the axis of the proportional tracer x , and the axis of tracer z moves in a path farther from the wall of the line-space than the axis of tracer x , so that these two tracers y and z , respectively, increase and decrease the extent of right-and-left movement of the tracer in tracing the vertical lines, and this increase and decrease is made such by calculation, as above described, as to compensate for the decrease or increase in weight of the vertical lines which would result from the non-proportional reduction for condensation or extension. In tracing a type-pattern the same tracers may be used for the same condensation or extension as in tracing a matrix-pattern, but tracer y will then be used in condensation and tracer z in extension. From the above explanation the proper form of compensating tracer for different conditions will be understood and may readily be calculated. It will be understood that where the vertical lines vary in weight only an approximate compensation for condensation or extension can be secured by such a compensating tracer, but by calculating the tracer according to the average width of the vertical lines a sufficiently accurate compensation can usually be secured even in such cases. While this compensating-tracer feature has been described only in connection with the reduction of patterns for condensation or extension of type, it is obvious that it is equally applicable in non-proportional reductions or expansions from a pattern for many other purposes and in machines of widely different classes.

A specific feature of the machine shown that is important in practice consists of the mounting of the tool-holder so that its adjusted position is not affected by expansion or contraction of the metal parts in or by which it is supported. Heretofore in similar machines the tool-holder has been supported from one side on the machine and in such a manner that the expansion of the metal support of the tool resulting from the heating of the tool-bearing by the very high speed of the tool tends to move the cutting-tool and its bearing outward or away from the side on which the tool-support is mounted on the frame, thus moving the cutting-tool out of alignment. As the work of these machines requires extreme accuracy, this movement is sufficient to interfere seriously with the quality of the work, especially in cutting matrices for casting type. To overcome this defect, I support the cutting-tool in the center of its swinging frame by supports on opposite sides of the tool in such a manner that the expansion of the metal on all sides of the tool is the same, and I thus preserve the

proper position or alinement of the tool independently of expansion by heat.

The term "follower" is used herein as meaning the part to which the movement of the tracer is transmitted by the machine. In the machine shown the cutting-tool forms the follower moved by the tracer, and this is much preferable to moving the work-holder as the follower, especially in matrix-cutting, as it enables me to produce a more compact and efficient machine with convenient and accurate adjustments for positioning the matrix-bar and means for firmly holding it in adjusted position and to provide for cutting large matrices with a small machine. It will be understood, however, that my compensating tracer and many other features of the invention are applicable also to machines in which the tool is stationary and the work-holder forms the follower and that it is possible also to produce the tracing movement by moving the pattern along a stationary tracer instead of moving the tracer over the pattern. The invention and a machine of the form shown also are applicable in many other classes of engraving-work as well as cutting type matrices or punches, although especially designed for typework. It will be understood, also, that many modifications may be made in the machine shown without departing from the invention and that the invention is not to be limited to the exact form or arrangement of parts illustrated.

What I claim is—

1. The combination with swinging tracing-frame F having pairs of pivots 1, 2 forming a universal joint, and a follower actuated by said frame, one of said pairs of pivots being adjustable toward and from the follower independently of the other pair of said pivots, of screws for adjusting said adjustable pivots, and removable bearing-blocks limiting the movement of the pivots by the screws, substantially as described.

2. The combination with swinging tracing-frame F and plate E by which it is suspended, of frame D in which plate E is pivoted, and vertical pivot-bars 19 mounted on pivots 1 in the machine-frame and on which the frame D is vertically adjustable with plate E, substantially as described.

3. The combination with swinging tracing-frame F and suspending frame D and plate E, of vertical pivot-bars 19 having arms 20 and screws 21 passing through said arms for adjusting the frame D on the pivot-bars 19, substantially as described.

4. In a matrix-cutting machine, a matrix-holder having independently-adjustable side gages for the matrix-blank, and an end gage adjustable independently of the side gages, substantially as described.

5. In a matrix-cutting machine, a matrix-holder having independently-adjustable side gages for the matrix-blank, an end gage ad-

justable independently of the side gages, a top gage, and means for clamping the matrix-blank against the top gage and end gage, substantially as described.

6. In a matrix-cutting machine, a matrix-holder having independently-adjustable side gages an adjustable top gage and an adjustable end gage for the matrix-blank, and means for clamping the matrix-blank against the top gage and end gage, substantially as described.

7. In a matrix-cutting machine, a matrix-holder having independently-adjustable side gages and a top gage for the matrix-blank, and a vertical gage against which the matrix-blank is set up, and a clamp adapted to force the matrix-blank vertically against the lower face of the top gage and horizontally against the vertical gage, substantially as described.

8. In a matrix-cutting machine, a matrix-holder having a top gage for the matrix-blank, and a vertical gage against which the matrix-blank is set up, and a wedge-plate adapted to be forced under the matrix-blank and toward the vertical gage, substantially as described.

9. A matrix-holder having the base *k* provided with side flanges *k'*, *k*², adjusting-screws 83, 84 in said flanges, gage-blocks 86, 87, a top gage, and adjustable end gage 91, substantially as described.

10. A matrix-holder having the base *k* provided with side flanges *k'*, *k*², adjusting-screws 83, 84 in said flanges, gage-blocks 86, 87, an adjustable top gage, and adjustable end gage 91, substantially as described.

11. A matrix-holder having the base *k* provided with side flanges *k'*, *k*², adjusting-screws 83, 84 in said flanges, gage-blocks 86, 87, adjustable top gages 88, 89, and adjustable end gage 91, substantially as described.

12. A matrix-holder having the base *k* provided with side flanges *k'*, *k*², adjusting-screws 83, 84 in said flanges, gage-blocks 86, 87, adjustable top gages 88, 89, adjustable end gage 91, and wedge-plate 85 on the base *k*, substantially as described.

13. A matrix-holder having a top gage and a vertical gage for one edge of the matrix-blank, and wedge-plate 85 adapted to move toward the vertical gage below the matrix-blank, substantially as described.

14. A matrix-holder having a top gage and an adjustable end gage 91, gage-block 92 behind the gage 91, and wedge-plate 85 moving toward the gage 91, substantially as described.

15. The combination with standards B, of vertically-adjustable block J supported on said standards, vertically-adjustable block 50 set into block J, and a work-carrying block sliding into a groove in block 50, substantially as described.

16. The combination with block 50 having a groove and bolt 54 having head 55 entering

said groove, of a work-carrying block sliding in said groove and having a T-groove 51 receiving head 55, and means for adjusting bolt 54 to lock the work-carrying block down on block 50, substantially as described.

17. The combination with block 50, of screw-threaded sleeve 70 secured thereto, adjusting-bolt 72 entering said sleeve, a micrometer-disk for rotating said bolt in the sleeve to move the latter, and screw-sleeve 77 inclosing the bolt 72 for moving the bolt longitudinally with the disk and sleeve, substantially as described.

18. The combination with block 50, of screw-threaded sleeve 70 secured thereto, adjusting-bolt 72 entering said sleeve, a micrometer-disk for rotating said bolt, screw-sleeve 77 for moving the bolt longitudinally with the disk and sleeve, and nut 79 on the bolt outside the sleeve 77, substantially as described.

19. The combination with a swinging tracing-frame, and pivots 1, 1, and 2, 2, by which the frame is mounted, of a tracer for controlling the frame, a follower actuated by the frame, means for adjusting one set of said pivots independently of the other set and of the follower to vary one component of the tracing movement relatively to the other component in transmission to the follower, and a pattern-holder adjustable angularly in the plane of tracing movement, substantially as set forth.

20. The combination with a swinging tracing-frame, and pivots 1, 1, and 2, 2, by which the frame is mounted, of a tracer for controlling the frame, a follower actuated by the frame, means for adjusting one set of said pivots independently of the other set and of the follower to vary one component of the tracing movement relatively to the other component in transmission to the follower, and a pattern-holder and work-holder adjustable angularly in the plane of tracing movement, substantially as set forth.

21. The combination with swinging tracing-frame F, and pivots 1, 1, and 2, 2, by which the frame is suspended above the follower, of a follower actuated by the frame, and means for adjusting one set of said pivots vertically independently of the other set and of the follower to vary one component of the tracing movement relatively to the other component in transmission to the follower, and a pattern-holder adjustable angularly in the plane of tracing movement, substantially as described.

22. The combination with swinging tracing-frame F, pivots 1, 1, and 2, 2, by which the frame is suspended, and a follower actuated by the frame, of means for adjusting one set of said pivots vertically independently of the other set and of the follower to vary one component of the tracing movement relatively to the other component in transmis-

sion to the follower, and a pattern-holder adjustable angularly in the plane of tracing movement and a tracer having its tracing portion oblong in cross-section with its two dimensions such as to compensate for the difference between the ratios in which the two components of the tracing movement are modified, substantially as described.

23. The combination with a tracer, a pattern, a universal joint having axes movable relatively to each other a swinging frame suspended from said universal joint and actuated by the tracing movement, and a follower actuated by said swinging frame to reproduce a pattern, of means for varying the relative angular position of the frame and pattern in planes parallel with the plane of tracing movement, and means for adjusting the universal joint to vary the ratios in which the components of the tracing movement are transmitted from the tracer to the follower, to produce back-sloped or italicized designs, substantially as described.

24. The combination with a tracer, a pattern, a universal joint having axes movable relatively to each other a swinging frame suspended from said universal joint and actuated by the tracing movement, and a follower actuated by said swinging frame to reproduce a pattern, of means for adjusting the work and the pattern angularly to the frame in planes parallel with the plane of tracing movement, and means for adjusting the universal joint to vary the ratios in which the components of the tracing movement are transmitted from the tracer to the follower, to produce back-sloped or italicized designs, substantially as described.

25. The combination with a tracer, a universal joint having axes movable relatively to each other a swinging frame suspended from said universal joint and actuated by the tracing movement, and a follower actuated by said swinging frame to reproduce a pattern, of a pattern-holder rotatable in a plane parallel with the plane of tracing movement, and means for adjusting the universal joint to vary the ratios in which the components of the tracing movement are transmitted from the tracer to the follower, to produce back-sloped or italicized designs, substantially as described.

26. The combination with a tracer, a universal joint having axes movable relatively to each other a swinging frame suspended from said universal joint and actuated by the tracing movement, and a follower actuated by said swinging frame to reproduce a pattern, of means for adjusting the work and the pattern angularly to the frame in the plane of tracing movement including a work-holder and a pattern-holder, both rotatable in planes parallel with the plane of tracing movement, and means for adjusting the universal joint to vary the ratios in which the components of

the tracing movement are transmitted from the tracer to the follower, to produce back-sloped or italicized designs, substantially as described.

5 27. The combination with a support having a circular unthreaded opening with an enlarged outer threaded portion, of pivot-screw 1 therein having a reduced unthreaded pivot portion and enlarged screw-head, and
10 set-screw 1^a engaging the unthreaded portion

of the pivot - screw 1, substantially as described.

In testimony whereof I have hereunto set my hand in the presence of two subscribing witnesses.

LINN BOYD BENTON.

Witnesses:

S. WINTHAL,
T. F. KEHOE.

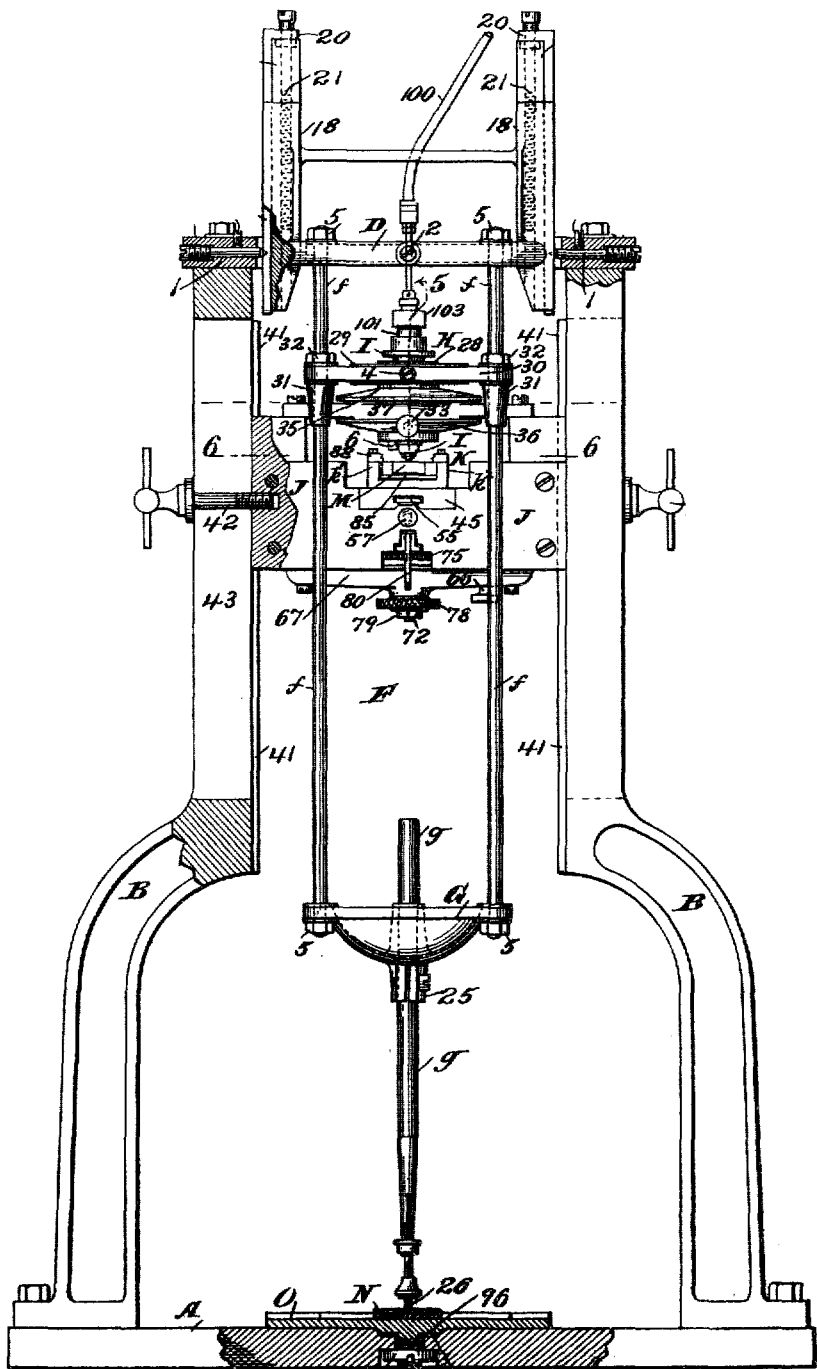

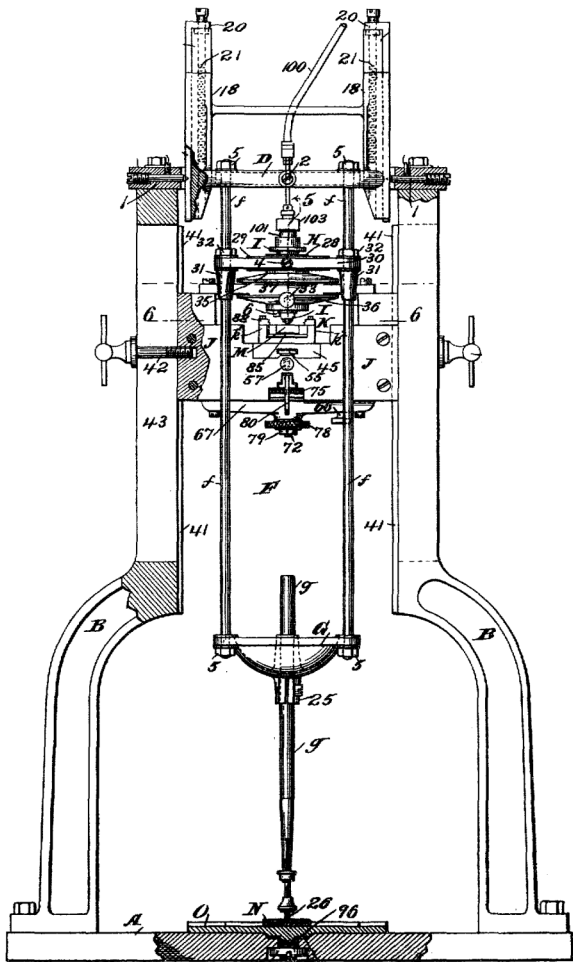

Fig. 1.

